



Heating and Air Conditioning

***INSTALLATION MANUAL***

**AFFINITY**

**COMMERCIAL GEOTHERMAL/  
WATER SOURCE HEAT PUMPS  
DUAL-CAPACITY HYDRONIC**

**MODELS:**

**YHTW100 - 180**

**(8 THRU 15 NOMINAL TONS)**



Due to continuous product improvement, specifications are subject to change without notice.

Visit us on the web at [www.york-geothermal.com](http://www.york-geothermal.com)

Additional rating information can found at [www.ahridirectory.org](http://www.ahridirectory.org)

FOR DISTRIBUTION USE ONLY - NOT TO BE USED AT POINT OF RETAIL SALE



## Table of Contents

---

Model Nomenclature .....	4
General Installation Information .....	5
Dimensional Data .....	6
Physical Data .....	7
Field Connected Water Piping .....	8-9
Typical Application Piping .....	10
Water Quality .....	11
Electrical Data .....	12
Wiring Schematics .....	13-15
Field Wiring and Controls Setup .....	16-17
Control Features .....	18-19
Sequence of Operation .....	20
Inputs and Output Configuration .....	21
Unit Display and Interface .....	22-24
Reference Calculations .....	25
Legend and Notes .....	25
Unit Startup .....	26
Operating Parameters .....	27
Load and Source Pressure Drop .....	28
Thermistor and Compressor Resistance .....	28
Heat of Extraction/Rejection Data .....	28
Heating and Cooling Cycle Analysis .....	29
Startup and Troubleshooting Form .....	30
Troubleshooting .....	31
Preventative Maintenance .....	32
Service Parts List .....	33
Revision Guide .....	34

# Model Nomenclature

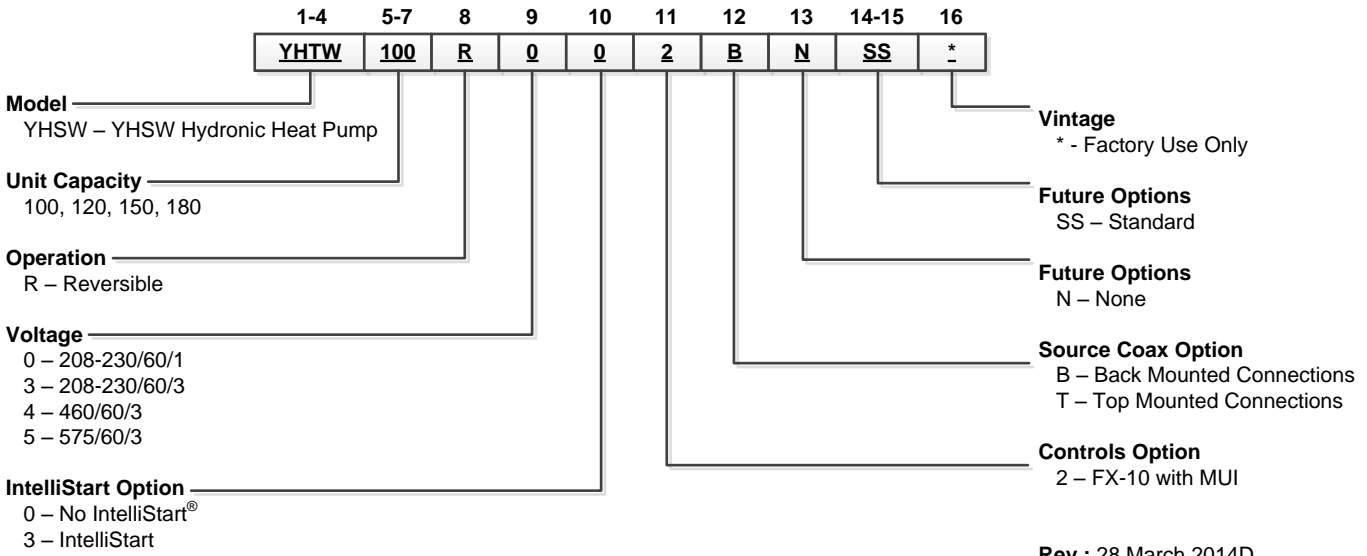

Rev.: 28 March 2014D

**Notes:**

- 1 Available on 040, 050, 060 and 075 only. Hot Water Generator requires field installed external pump kit.
- 2 018 and 025 heating only models are available only with copper double wall vented load coax for potable water.

## General Installation Information

### Safety Considerations

Installing and servicing air conditioning and heating equipment can be hazardous due to system pressure and electrical components. Only trained and qualified service personnel should install, repair or service heating and air conditioning equipment. When working on heating and air conditioning equipment, observe precautions in the literature, tags and labels attached to the unit and other safety precautions that may apply.

Follow all safety codes. Wear safety glasses and work gloves. Use quenching cloth for brazing operations. Have fire extinguisher available for all brazing operations.

**NOTE:** Before installing, check voltage of unit(s) to ensure proper voltage.



**WARNING:** Before performing service or maintenance operations on the system, turn off main power switches to the unit. Electrical shock could cause serious personal injury.

### Application

Units are not intended for heating domestic (potable) water by direct coupling. If used for this type of application, a secondary heat exchanger must be used.

### Moving and Storage

Move units in the normal "Up" orientation as indicated by the labels on the unit packaging. When the equipment is received, all items should be carefully checked against the bill of lading to ensure that all crates and cartons have been received in good condition. Examine units for shipping damage, removing unit packaging if necessary to properly inspect unit. Units in question should also be internally inspected. If any damage is observed, the carrier should make the proper notation on delivery receipt acknowledging the damage. Units are to be stored in a location that provides adequate protection from dirt, debris and moisture.



**WARNING:** To avoid equipment damage, do not leave the system filled in a building without heat during cold weather, unless adequate freeze protection levels of antifreeze are used. Heat exchangers do not fully drain and will freeze unless protected, causing permanent damage.

### Unit Location

Provide sufficient room to make water and electrical connections. If the unit is located in a confined space, provisions must be made for unit servicing. Locate the unit in an indoor area that allows easy removal of the access panels and has enough space for service personnel to perform maintenance or repair. These units are not approved for outdoor installation and, therefore, must be installed inside the structure being conditioned. Do not locate units in areas subject to freezing conditions.



**WARNING:** Do not store or install units in corrosive environments or in locations subject to temperature or humidity extremes (e.g. attics, garages, rooftops, etc.). Corrosive conditions and high temperature or humidity can significantly reduce performance, reliability, and service life.



**WARNING:** To avoid equipment damage and possible voiding of warranty, be sure that properly sized strainers are installed upstream of both brazed plate heat exchangers to protect them against particles in the fluid.

### Mounting Units

Prior to setting the unit in place, remove and discard both compressor hold down shipping bolts located at the front of each compressor mounting bracket. Units should be mounted level on a vibration absorbing pad slightly larger than the base to provide isolation between the unit and the floor. It is not necessary to anchor the unit to the floor. Allow access to the front, back, and side access panels for servicing.

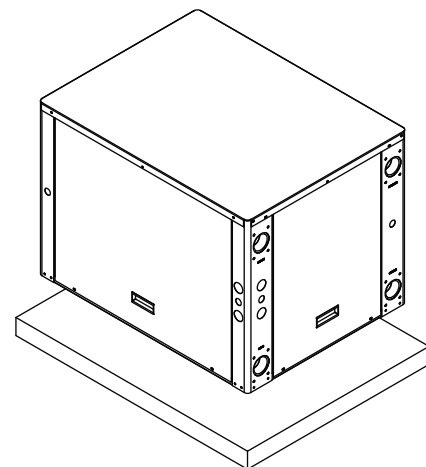

Vibration Pad Mounting

## Dimensional Data

### YHTW100-180 - Top Waterline Configuration

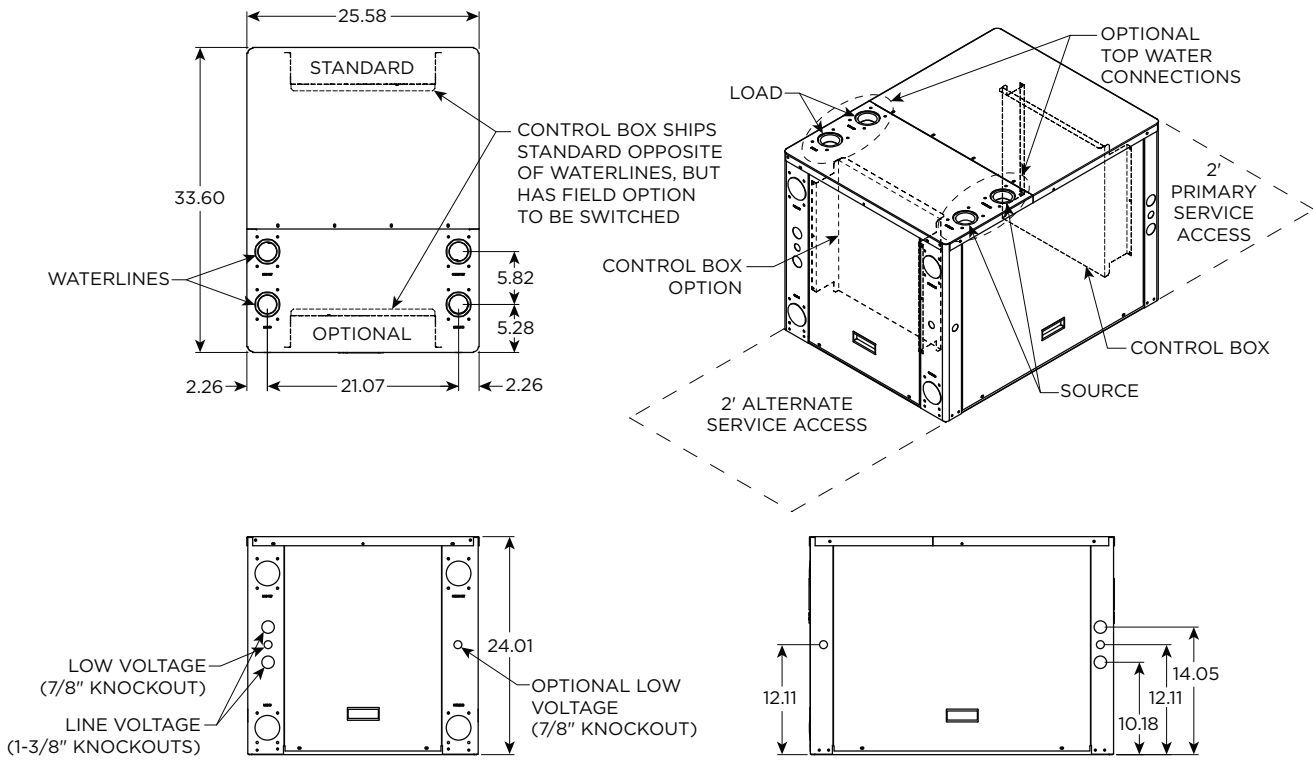

### YHTW100-180 - Back Waterline Configuration

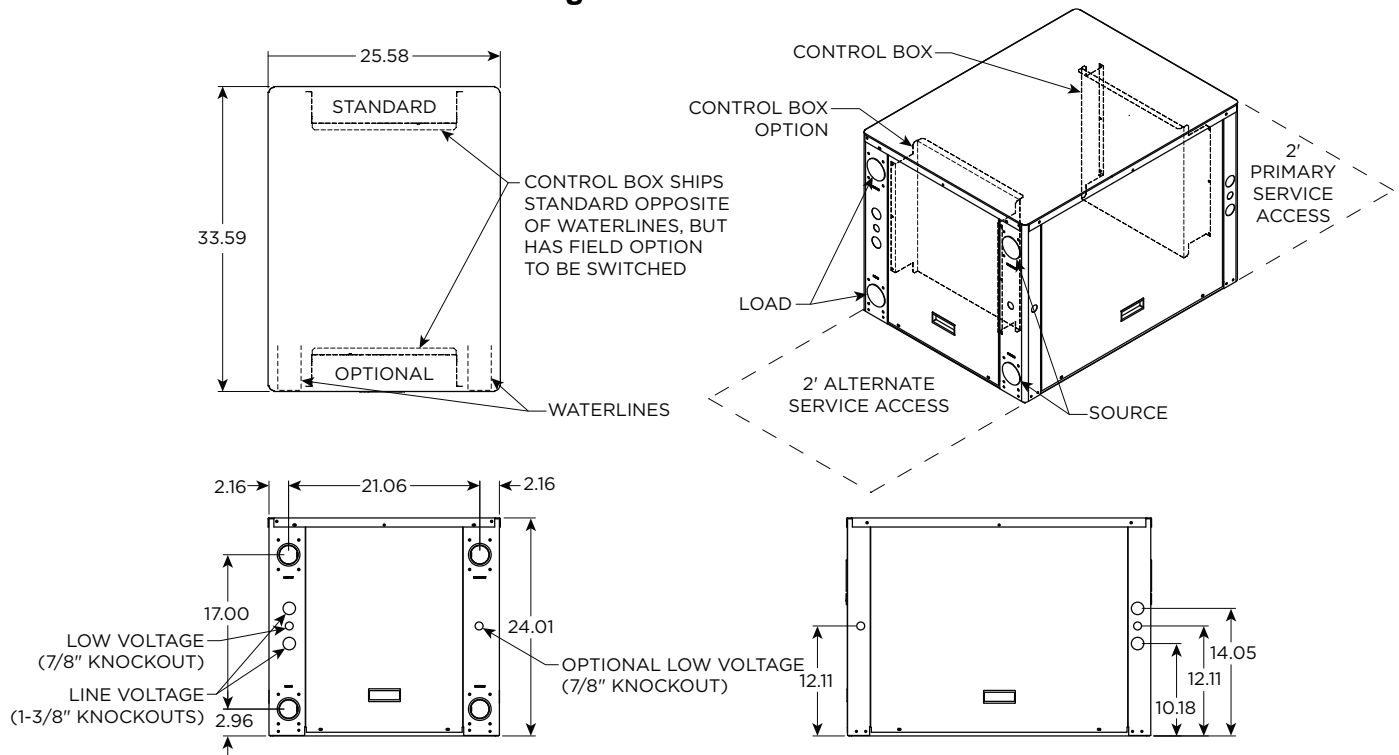

## Physical Data

Model	Model			
	100	120	150	180
Compressor (2 each)	Scroll			
Factory Charge R410A, oz [kg]	62 [1.76]	62 [1.76]	62 [1.76]	62 [1.76]
Load Water Connection				
FPT - in	2	2	2	2
Source Water Connection				
FPT - in	2	2	2	2
Weight - Operating, lb [kg]	390 [177]	400 [181]	400 [181]	420 [190]
Weight - Packaged, lb [kg]	385 [175]	395 [179]	395 [179]	415 [188]

3/9/09

# Field Connected Water Piping

## General

Each unit is equipped with captive 2 in. [50.8 mm] FPT water connections to eliminate ‘egg-shaping’ from use of a backup wrench. For making the water connections to the unit, a Teflon tape thread sealant is recommended to minimize internal fouling of the piping. Do not over tighten connections.

**NOTE: Units are factory run-tested using propylene glycol. Prior to connecting piping to unit, thoroughly flush heat exchangers.**

The piping installation should provide service personnel with the ability to measure water temperatures and pressures. The water lines should be routed so as not to interfere with access to the unit. The use of a short length of high pressure hose with a swivel type fitting may simplify the connections and prevent vibration. Optional stainless steel hose kits are available as an accessory item.

Before final connection to the unit, the supply and return hose kits must be connected, and the system flushed to remove dirt, piping chips and other foreign material. Normally, a combination balancing and close-off (ball) valve is installed at the return, and a rated gate or ball valve is installed at the supply. The return valve can be adjusted to obtain the proper water flow. The valves allow the unit to be removed for servicing. Both source as well as load fluid piping must be at least as large as the unit connections on the heat pump (larger on long runs).

Never use flexible hoses of a smaller inside diameter than that of the water connection on the unit and limit hose length to 10 ft. per connection. Check carefully for water leaks.

## Load and Source Piping Connections

The Affinity Series has two connection options available. Each kit is intended to connect one piping connection. Therefore, two kits will be required for each unit. The kits can be mixed for installer convenience, one on source and the other on load.

*CKNDW1* - Strainer Connection Kit includes a 2" copper tee with integral P/T plug and a 2" "Y" strainer. Other components to complete the all copper piping can be sourced locally.

*HHK162S* - Strainer Hose Kit set includes 2" Hose kit includes a 2" stainless steel braided hose with integral P/T plug and 2" "Y" strainer.

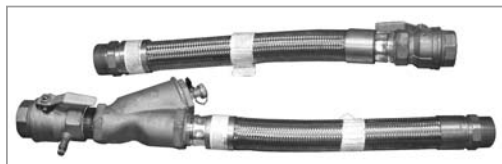

HHK162S



CKNDW1

## Water Flow Rate

The proper water flow must be delivered to each unit whenever the unit heats or cools. To assure proper flow, the use of pressure/temperature ports is recommended to determine the flow rate. These ports should be located adjacent to the supply and return connections on the unit. The proper flow rate cannot be accurately set without measuring the water pressure drop through the refrigerant-to-water heat exchanger (See Pressure Drop Table for water flow and pressure drop information).

## Load Flow Rate

The load flow on all water to water products including the Affinity Series should be 3 gpm per ton (typically the rated flow and the highest flow shown in the capacity charts). Refer to the table below. This flow rate is required especially when heating water to limit the effects of the higher condensing temperatures of water heating for radiant floor heating or domestic water use.

## Source Flow Rate

The source flow can range between 2.25 and 3 gpm per ton for earth loops. For open loop well water systems the minimum flow should be 1.5 gpm per ton. In earth loop systems where entering water temperatures are expected to be above 95°F, 3 gpm per ton should be used. In well systems where the water temperature is below 50°F, 2 gpm per ton should be used to avoid nuisance freeze detection trips.

	Source Flow Rate			Load Flow Rate
	Minimum Open Loop	Open Loop < 50°F	Closed Loop Range (Min - Full Flow)	
100	15	20	23   30	30
120	18	24	27   36	36
150	21	28	32   42	42
180	24	32	36   48	48

## Flushing

Flushing the system of debris is especially important in brazed plate heat exchanger systems. These systems have many small parallel flow paths in which debris can clog. Initial flushing of the system can be accomplished in one of two ways. First flushing the piping system toward the strainer will allow the strainers to capture all debris prior the heat exchangers and commissioning. Secondly a temporary bypass can be included in the piping design so that the heat pump itself can be bypassed during the initial flushing stage with an external strainer gathering the debris.



**CAUTION: Water piping exposed to outside temperature may be subject to freezing.**



## Field Connected Water Piping cont.

### Closed Loop Tower/Boiler Systems

The water loop is usually maintained between 60°F [15.5°C] and 90°F [32.2°C] for proper heating and cooling operation. This is accomplished with a cooling tower and a boiler.

To reject excess heat from the condenser water loop, the use of a closed-circuit evaporative cooler or an open type cooling tower with a secondary heat exchanger between the tower and the condenser water loop is recommended. If an open type cooling tower is used without a secondary heat exchanger, continuous chemical treatment and filtering of the water must be performed to ensure the water is free from damaging materials.



**CAUTION:** Water piping exposed to outside temperature may be subject to freezing.

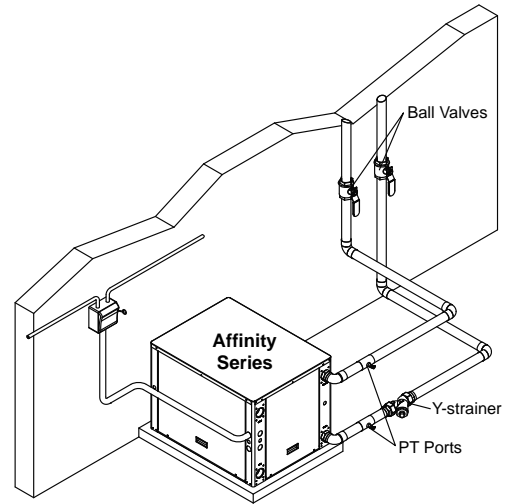

**Closed Loop (Boiler/Tower) Systems**

### Open Loop Well Water Systems

Installation of an open loop system is not recommended unless water quality guidelines are met.

### Earth Coupled Systems

All supply and return water piping should be insulated to prevent excess condensation from forming on the water lines. Ensure pumping system is capable of providing adequate flow rate at the system pressure drop, 3.0 GPM per ton [0.054 LPS per kW] (source side) is recommended. Antifreeze in the loop is strongly recommended.

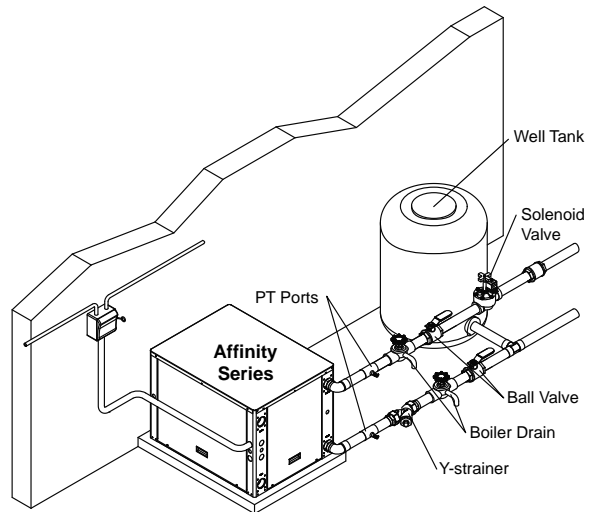

**Open Loop Well Water Systems**

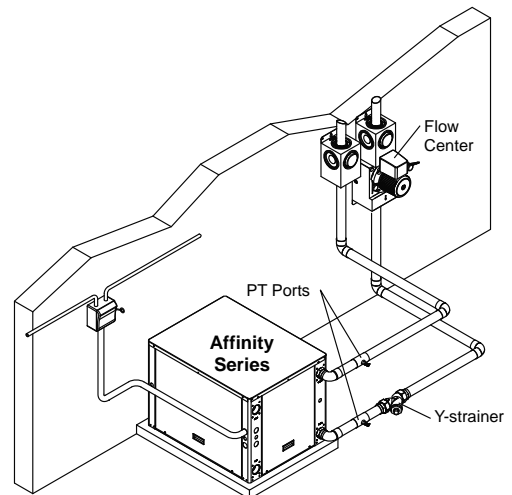

**Earth Coupled Systems**

# Typical Application Piping

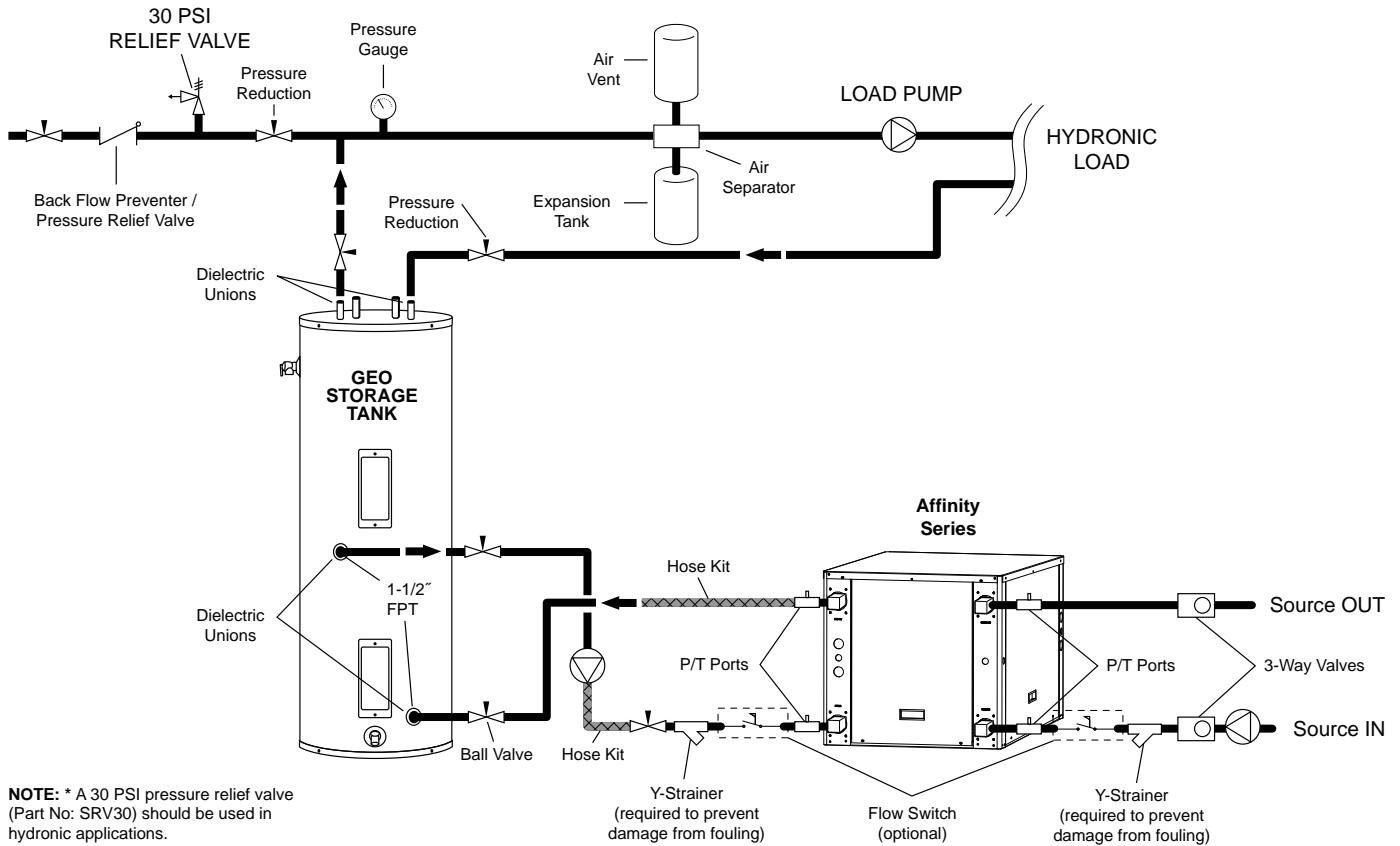

# Water Quality

## General

Affinity systems may be successfully applied in a wide range of residential, commercial, and industrial applications. It is the responsibility of the system designer and installing contractor to ensure that acceptable water quality is present and that all applicable codes have been met in these installations.

## Water Treatment

The use of improperly treated or untreated water in this equipment may result in scaling, erosion, corrosion, algae or slime. The services of a qualified water treatment specialist should be engaged to determine what treatment, if any, is required. The product warranty specifically excludes liability for corrosion, erosion or deterioration of equipment.

The heat exchangers in the units are 316 stainless steel plates with copper brazing. The water piping in the heat exchanger is steel. There may be other materials in the building's piping system that the designer may need to take into consideration when deciding the parameters of the water quality.

If an antifreeze or water treatment solution is to be used, the designer should confirm it does not have a detrimental effect on the materials in the system.

## Contaminated Water

In applications where the water quality cannot be held to prescribed limits, the use of a secondary or intermediate heat exchanger is recommended to separate the unit from the contaminated water.

The following table outlines the water quality guidelines for unit heat exchangers. If these conditions are exceeded, a secondary heat exchanger is required. Failure to supply a secondary heat exchanger where needed will result in a warranty exclusion for primary heat exchanger corrosion or failure.

## Strainers

These units must have properly sized strainers upstream of both brazed plate heat exchangers to protect them against particles in the fluid. Failure to install proper strainers and perform regular service can result in serious damage to the unit, and cause degraded performance, reduced operating life and failed compressors. Improper installation of the unit (which includes not having proper strainers to protect the heat exchangers) can also result in voiding the warranty.

Field supplied strainers with 20-40 mesh (530-1060 microns) are recommended, with 30 mesh (800 microns) being the optimum choice. The strainers selected should have a mesh open area of at least 6 square inches (39 square centimeters) for each unit being serviced by the strainer. Using strainers with a smaller amount of open area will result in the need for more frequent cleaning.

Strainers should be selected on the basis of acceptable pressure drop, and not on pipe diameter. The strainers selected should have a pressure drop at the nominal flow rate of the units low enough to be within the pumping capacity of the pump being used.



**WARNING: Must have intermediate heat exchanger when used in pool applications.**

## Water Quality Guidelines

Material		Copper	90/10 Cupronickel	316 Stainless Steel
pH	Acidity/Alkalinity	7 - 9	7 - 9	7 - 9
Scaling	Calcium and Magnesium Carbonate	(Total Hardness) less than 350 ppm	(Total Hardness) less than 350 ppm	(Total Hardness) less than 350 ppm
Corrosion	Hydrogen Sulfide	Less than 0.5 ppm (rotten egg smell appears at 0.5 ppm)	10 - 50 ppm	Less than 1 ppm
	Sulfates	Less than 125 ppm	Less than 125 ppm	Less than 200 ppm
	Chlorine	Less than 0.5 ppm	Less than 0.5 ppm	Less than 0.5 ppm
	Chlorides	Less than 20 ppm	Less than 125 ppm	Less than 300 ppm
	Carbon Dioxide	Less than 50 ppm	10 - 50 ppm	10 - 50 ppm
	Ammonia	Less than 2 ppm	Less than 2 ppm	Less than 20 ppm
	Ammonia Chloride	Less than 0.5 ppm	Less than 0.5 ppm	Less than 0.5 ppm
	Ammonia Nitrate	Less than 0.5 ppm	Less than 0.5 ppm	Less than 0.5 ppm
	Ammonia Hydroxide	Less than 0.5 ppm	Less than 0.5 ppm	Less than 0.5 ppm
	Ammonia Sulfate	Less than 0.5 ppm	Less than 0.5 ppm	Less than 0.5 ppm
	Total Dissolved Solids (TDS)	Less than 1000 ppm	1000 - 1500 ppm	1000 - 1500 ppm
	LSI Index	+0.5 to -0.5	+0.5 to -0.5	+0.5 to -0.5
Iron Fouling (Biological Growth)	Iron, FE <sup>2+</sup> (Ferrous) Bacterial Iron Potential	< 0.2 ppm	< 0.2 ppm	< 0.2 ppm
	Iron Oxide	Less than 1 ppm, above this level deposition will occur	Less than 1 ppm, above this level deposition will occur	Less than 1 ppm, above this level deposition will occur
Erosion	Suspended Solids	Less than 10 ppm and filtered for max. of 600 micron size	Less than 10 ppm and filtered for max. of 600 micron size	Less than 10 ppm and filtered for max. of 600 micron size
	Threshold Velocity (Fresh Water)	< 6 ft/sec	< 6 ft/sec	< 6 ft/sec

NOTES: Grains = ppm divided by 17  
mg/L is equivalent to ppm

2/22/12

# Electrical Data

Model	Supply Circuit	Rated Voltage	Voltage Min/Max	Compressor*				Load Pump FLA	Source Pump FLA	Total Unit FLA	Min Circ Amp	Max Fuse/HACR
				MCC	RLA	LRA	LRA**					
100	L1/L2	208-230/60/1	187/253	41.2	26.4	134.0	47.0	-	-	26.4	33.0	50
	L3/L4	208-230/60/1	187/253	41.2	26.4	134.0	47.0	4.2	4.2	34.8	41.4	60
	Single	208-230/60/3	187/253	24.9	16.0	110.0	66.0	-	-	32.0	36.0	50
	Single	460/60/3	414/506	12.1	7.8	52.0	31.0	-	-	15.6	17.6	25
	Single	575/60/3	517/633	8.9	5.7	38.9	-	-	-	11.4	12.8	15
120	L1/L2	208-230/60/1	187/253	47.0	30.1	145.0	51.0	-	-	30.1	37.6	60
	L3/L4	208-230/60/1	187/253	47.0	30.1	145.0	51.0	4.2	4.2	38.5	46.0	70
	Single	208-230/60/3	187/253	28.0	17.3	120.0	72.0	-	-	34.6	38.9	50
	Single	460/60/3	414/506	15.0	9.6	70.0	42.0	-	-	19.2	21.6	30
	Single	575/60/3	517/633	12.5	8.0	53.0	-	-	-	16.0	18.0	25
150	L1/L2	208-230/60/1	187/253	42.0	26.9	145.0	51.0	-	-	26.9	33.6	60
	L3/L4	208-230/60/1	187/253	42.0	26.9	145.0	51.0	4.2	4.2	35.3	42.0	60
	Single	208-230/60/3	187/253	35.0	22.4	190.0	114.0	-	-	44.8	50.4	70
	Single	460/60/3	414/506	19.0	12.2	87.0	52.0	-	-	24.4	27.5	30
	Single	575/60/3	517/633	15.0	9.6	62.0	-	-	-	19.2	21.6	30
180	L1/L2	208-230/60/1	187/253	50.0	32.1	185.0	65.0	-	-	32.1	40.1	70
	L3/L4	208-230/60/1	187/253	50.0	32.1	185.0	65.0	4.2	4.2	40.5	48.5	80
	Single	208-230/60/3	187/253	39.0	26.0	190.0	114.0	-	-	52.0	58.5	80
	Single	460/60/3	414/506	19.0	13.0	100.0	60.0	-	-	26.0	29.3	40
	Single	575/60/3	517/633	14.5	9.3	72.0	-	-	-	18.6	20.9	30

HACR circuit breaker in USA only

\* Ratings per each compressor - unit supplied with two

\*\* With optional IntelliStart

3/7/13

Figure 1 - Control Box

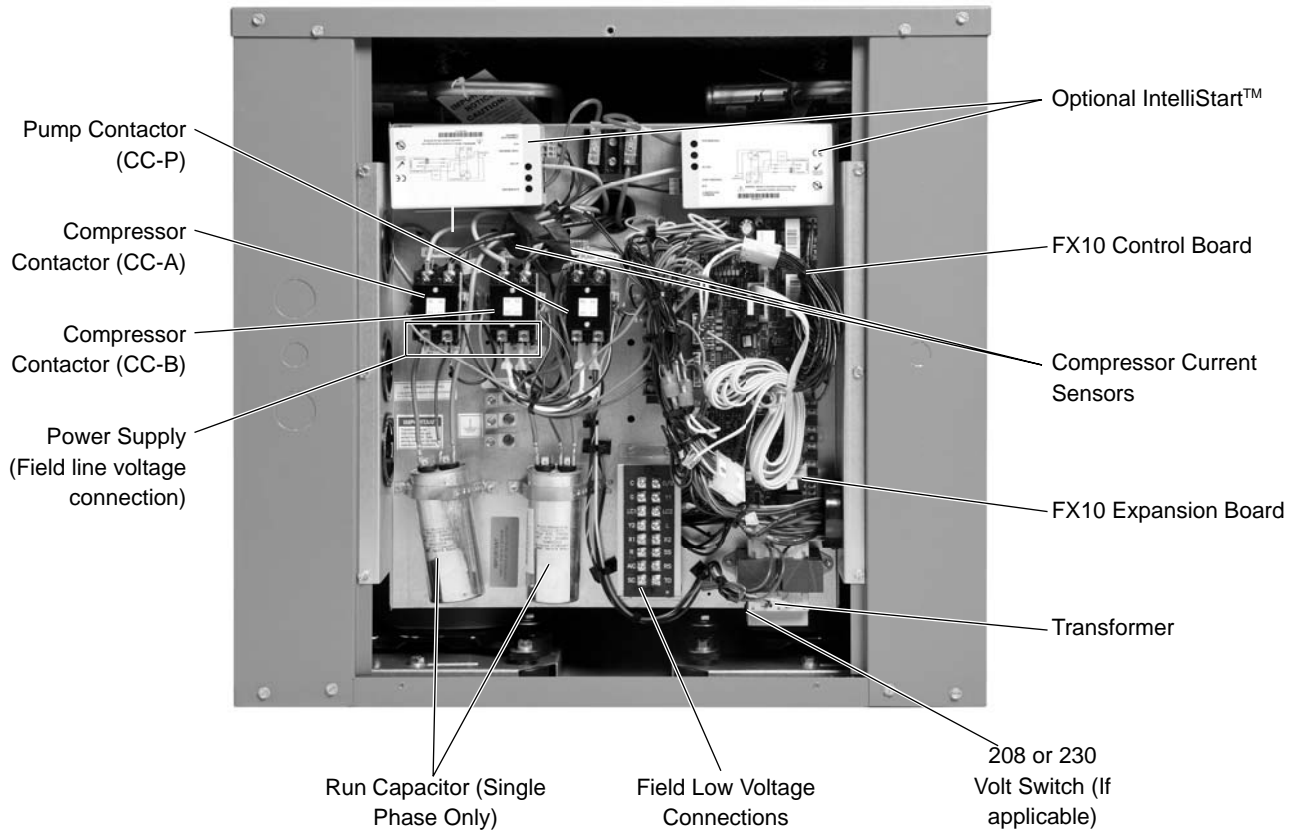





# Wiring Schematics cont.

## MUI Wiring Diagram

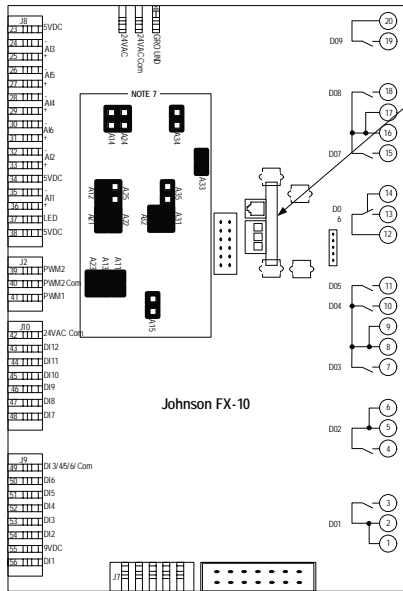

# Field Wiring and Control Setup

Figure 2 - High Voltage Connections

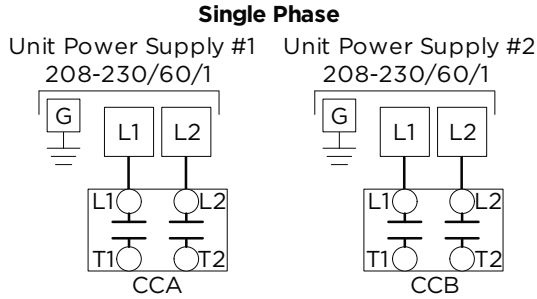
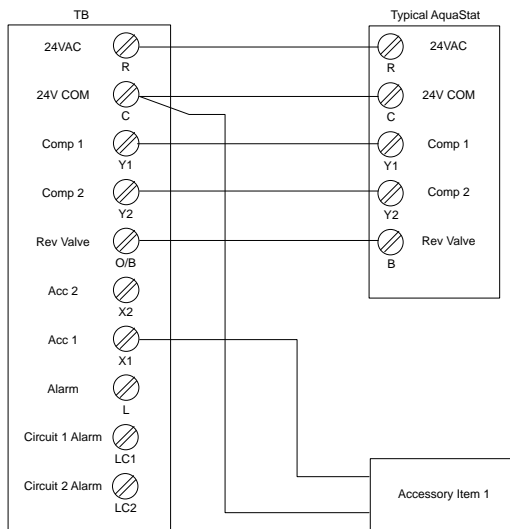
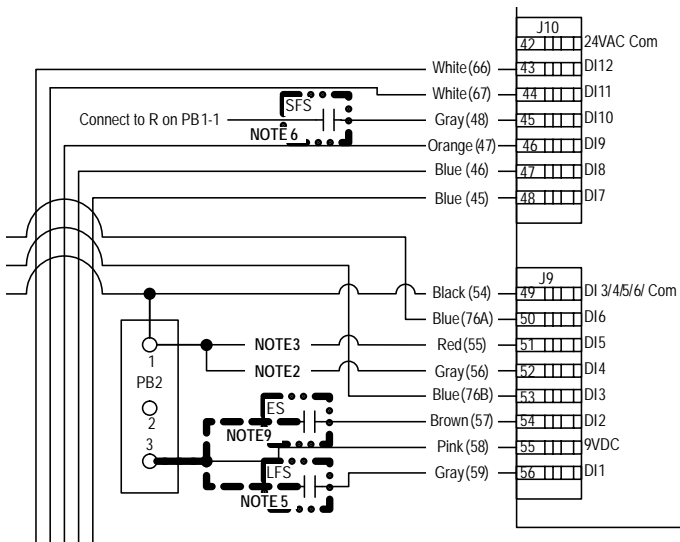

Figure 3 - Low Voltage Connections



NOTES:  
 1) Acc Output 1 is cycled with the lead compressor  
 2) Acc Output 2 is cycled with the lag compressor

Figure 4 - Wiring Schematic



## Line Voltage

### High Voltage Connections

Connect power wiring as shown in Figure 2.

### 208 Volt Operation

Switch red and blue transformer wires for 208V operation.

## Low Voltage Operation

### Thermostat/Controller (AquaStat)

A two-stage 24 VAC thermostat or liquid controller (field supplied) must be used to turn the Affinity on or off, and to switch it from cooling to heating if necessary. Multiple YHTWs in the same bank must be controlled from one thermostat/controller (must be isolation relays for multiple unit applications).

### Low Voltage Connections

Connect low voltage thermostat wiring as shown in Figure 3. Connections shown are for typical thermostat. Actual connections may vary with specific device used.

**NOTE:** If a separate transformer is used to supply a Y1, Y2, or B signal to the unit controls, isolation relays must be used.

**CAUTION:** Use only copper conductors for field installed wiring. Terminals in the unit are not designed for other types of conductors.

**WARNING:** All wiring must comply with local and state codes. Disconnect the power supply before beginning to wire to prevent electrical shock or equipment damage.

**NOTE:** Accessory output is selectable as normally open or normally closed using the unit display. Normally closed is the factory default setting.

### Source Flow Switch (SFS)

Unit is factory shipped with jumpers on the Source Flow Switch pins J10-45 (entering). Flow proving switch is optional, hook up as shown in Fig. 4 and Note 6. The unit will not operate without a flow proving switch or jumper installed.

### Load Flow Switch (LFS)

Unit is factory shipped with jumpers on the Load Flow Switch pins J9-56 (leaving). Flow proving switch is optional, hook up as shown in Fig. 4 and Note 5. The unit will not operate without a flow proving switch or jumper installed.

### Load and Source Pump

The load or source pump connection allows for 4.2 A at 208/60/1 on each (208/60/1 models only). This pump supply should be adequate for most applications. Please consult the electrical schematic and table for more detail.



---

## Field Wiring and Control Setup cont.

---

### Accessory Relay Setup

The accessory output set to “close” upon Y1 compressor call (compressor is delayed 90 sec. after Y1) but can be set to “open” with Y1.

To change ACC1:

- Using up and down keys, scroll to “Acc 1 Sel” hit “ENTER” and “ON Comp” begins flashing
- Using up and down keys, select “ON Comp” for activation with Y1 Call or “OFF Comp” for deactivation with Y1

### Lead/Lag Selection

Compressor Lead/Lag Selection is factory set to “ON” but can be set to “OFF”.

To change Lead/Lag On/Off:

- Using up and down keys, scroll to “LEAD/LAG SELECT” hit “ENTER” and “OFF” begins flashing
- Using up and down keys, select “ON” for activation or “ OFF” for deactivation

### °F or °C - Unit of Measure

Degrees Fahrenheit is factory set, however degrees Celsius can be selected using the following procedure:

To Change Unit of Measure:

- On FX10 control using up and down keys, scroll to “SETTINGS”
- Using up and down keys, scroll to “UNIT OF MEASURE” hit “ENTER” and “UNIT OF MEASURE” begins flashing
- Using up and down keys, select “F” for degrees Fahrenheit or “C” for degrees Celsius

### Other Field Options

Other field selectable options are available as shown in the maintenance menu on page 24 of the FX10 control using a similar procedure as shown in the above examples. These would include thermostat enabling, and emergency shutdown.

## Control Features

Anti Short Cycle  
 High Pressure Protection  
 Low Pressure Protection  
 Advanced Freeze Detection Setpoint  
 Random Start  
 Display for diagnostics  
 Reset Lockout at disconnect  
 Intelligent reset for field installed flow switches  
 1 Accessory output  
 Compressor Lead/Lag  
 Compressor Current Switches

### Field Selectable Options

#### Freeze Detection Sensing Select (DI-4 and DI-5)

The freeze detection temperature sensing selection inputs allow the user to adjust the setpoints. The source sensors are wired to inputs AI-3 and AI-4 while the load sensors are wired to inputs AI-5 and AI-6. The setpoints for both, the load and source, are factory set for 33°F. In order to change the setpoint to 15°F on the source, remove the jumper wire from DI-4 (wire #56). The load setpoint can be changed by removing the jumper wire from DI-5 (wire #55).

#### Accessory Output (DO-4)

The accessory output will be energized 90 seconds prior to the lead compressor output being energized. When the lead compressor output is turned off the accessory output will be deactivated immediately. The output is selectable for normally open or normally closed operation through the unit mounted user interface or from a building automation system.

## Control and Safety Features

### Emergency Shutdown

The emergency shutdown mode can be activated by a command from a facility management system or a closed contact on DI-2. The default state for the emergency shutdown data point is off. When the emergency shutdown mode is activated, all outputs will be turned off immediately and will remain off until the emergency shutdown mode is deactivated. The first time the compressor starts after the emergency shutdown mode has been deactivated, there will be a random start delay present.

### Lockout Mode

Lockout mode can be activated by any of the following fault signals: refrigerant system high pressure, refrigerant system low pressure, heating freeze detection, cooling freeze detection, and compressor current sensor. When any valid fault signal remains continuously active for the length of its recognition delay, the controller will go into fault retry mode, which will turn off the compressor. After the Compressor short cycle delay, the compressor will attempt to operate once again. If three consecutive faults are recognized during a single heating or cooling demand, the unit will go into lockout mode, turning off the compressor and enabling the alarm output until the controller is reset. The fault count will automatically reset when the heating or cooling command becomes satisfied. If a fault occurs on a dual compressor unit, the other compressor will continue to operate based on the heating or cooling demand. The lockout condition can be reset by powering down the controller by holding both the enter and escape keys on the optional user interface.

## Advanced Freeze Detection System

The source and load heat exchangers are protected by a multi-sourced temperature logic strategy. The temperature logic is based upon the refrigerant temperature sensed as the refrigerant is about to enter the heat exchanger; while entering and leaving water temperatures are being used as correlating factors. The detection scheme is shown as basic and advanced algorithms.

### Basic Freeze Detection Operation: “Comp1 or Comp2 Freeze” Alarm

This alarm can be triggered by one of two detection schemes.

#### Hard Limit Freeze Detection

If the refrigerant temperature drops below the freeze detection setpoint by 1.8°F, the associated compressor is locked out immediately regardless of any other factors and requires a manual reset. **NOTE: This Lockout produces a “Comp 1 or Comp 2 Freeze” error on the MUI display.**

#### Freeze Detection

The refrigerant temperature is compared to the freeze detection setpoint (15°F [antifreeze] or 33°F [water] field selectable), and if the temperature falls below the setpoint for 30 continuous seconds, the associated compressor will be halted. This function becomes enabled after the first two minutes of compressor operation. Three such events in 60 minutes will trigger a compressor lockout that requires a manual reset. **NOTE: This Lockout produces a “Comp 1 or Comp 2 Freeze” error on the MUI display.**

#### In addition to the above:

##### *Entering Water Temperature Influence*

If the entering water temperature of the evaporative heat exchanger is within 10°F of the freeze setpoint, the previously mentioned two minute delay will be eliminated. This allows the freeze detection to operate immediately when the compressor starts based on entering water temperature.

##### *Leaving Water Temperature Influence*

If the leaving water temperature of the evaporative heat exchanger is within 10°F of the freeze setpoint, the previously mentioned 30 second delay will begin to be proportionately reduced, ending at a 1 second delay when the leaving water temperature is 1.5°F above the freeze setpoint.

##### *Dual Circuited Heat Exchanger Protection*

A low temperature condition on either refrigerant circuit will prevent the start of both compressors. If the low temperature condition exists for 5 minutes when both compressors are off, a lockout is triggered for both compressors. However, if for instance both compressors are operating and circuit 1 experiences a refrigerant temperature below the freeze detection setpoint such that compressor 1 is halted, compressor 2 will not be halted as a result.

## Control Features cont.

### Advanced Freeze Detection Operation: “Pre Freeze” Alarm

#### Predictive freeze condition detection:

If the refrigerant temperature is within 7.2°F of the freeze detection setpoint, the predictive freeze detection algorithm is enabled, and if the logic determines that a freeze condition is likely to happen based on current conditions, the compressor of the involved refrigerant circuit is immediately stopped. Three (3) such events in 60 minutes will trigger a compressor lockout that requires a manual reset. In the absence of such a condition, the compressor is allowed to operate so that the refrigerant temperature may eventually be at the threshold of the freeze detection setpoint. **NOTE: This Lockout produces a “Pre Freeze” detection error on the MUI display.**

#### Capacity Limiting

If the leaving water temperature drops to 1.8°F above the freeze detection setpoint, the lead compressor is halted. When the leaving water temperature rises to 3.6°F above the freeze detection setpoint, it will be allowed to resume operation. This limiting is allowed to repeat indefinitely. This causes “COMP1 Low Limit” to be displayed on the MUI.

If the leaving water temperature drops to the freeze detection setpoint, the lag compressor is halted. When the leaving water temperature rises to 1.8°F above the freeze detection setpoint, it will be allowed to resume operation. This limiting is allowed to repeat indefinitely. This causes “COMP2 Low Limit” to be displayed on the MUI.

#### Compressor Current Switch (AI-3 EXP and AI-4 EXP)

The compressor current switch is designed to insure that the compressor is on when the compressor output is energized. This switch is normally open and closes when current is flowing to the compressor. If the compressor fails to start the switch will open. The switch must be open for a continuous 5 seconds for a fault to occur. After 3 faults in 60 minutes the control will put the unit into an alarm state.

#### Optional Flow Proving Switch (DI-1 and DI-10)

The load and source flow-proving switches are optional and can be field installed. These switches shall be normally open flow switches that will close when the water flow through the heat exchangers reach an acceptable level. The flow-proving switches must be closed 15 seconds prior to enabling either compressor output (DO-1 and DO-2). If the load flow-proving switch opens at any time both compressor outputs (DO-1 and DO-2) must be disabled immediately.

#### High Pressure (DI-11 and DI-12)

The high-pressure switches shall be a normally closed (NC) switch that monitors the systems compressor discharge refrigerant pressures. There shall be an individual high pressure switch for each circuit. If the input senses the high-pressure switch is open during the period that the compressor output is enabled, it must shut down the compressor immediately and count the fault. The compressor minimum on time does not apply if the high-pressure switch trips. The compressor will not restart until the short cycle time delay has been satisfied. If the high-pressure fault occurs in one circuit the other compressor will continue to operate based on the heating or cooling demand.

#### Low Pressure (DI-3 and DI-6)

The low-pressure switches shall be a normally closed (NC) switch that monitors the systems compressor suction line refrigerant pressure. The input shall be checked 15 seconds before compressor start up to insure the pressure switch is closed and then ignored for the first 2 minutes after the compressor output (DO-1 or DO-2) is enabled. If the switch is open continuously for (30) seconds the compressor output for that circuit will be disabled. The compressor will not restart until the short cycle time delay has been satisfied. If a low-pressure fault occurs in one circuit the other compressor will continue to operate based on the heating or cooling demand.

#### Compressor 1 Alarm Output (DO-5)

The compressor 1 alarm output will be enabled when stage 1 is in the lockout mode and will be disabled when the lockout is reset.

#### Compressor 2 Alarm Output (DO-6)

The compressor 2 alarm output will be enabled when stage 2 is in the lockout mode and will be disabled when the lockout is reset.

#### Test Mode

The unit controls system can be put into test mode to eliminate startup delays to aid in trouble shooting. To put the unit into test mode hold the “ESC” and “Down Arrow” keys until LED 8 begins to flash. The control will remain in test mode until power is cycled or after 30 minutes.

## Sequence of Operation

### Power Fail Restart

When the controller is first powered up, the outputs will be disabled for a random start delay time (See Random Start Delay). The delay is provided to prevent simultaneous starting of multiple heat pumps. Once the timer expires, the controller will operate in the occupied mode until it is commanded to another mode by a remote thermostat. A restart status variable is available for indication of this occurrence.

### Random Start Delay

This delay will be used after every power failure, as well as the first time the compressor(s) is started after the control exits the emergency shutdown mode. The default time period for the start delay will be random between 1 and 120 seconds.

### Compressor Fixed On Delay Time

The Compressor Fixed On Delay Time will ensure that the compressor output is not enabled for (90) seconds after the control receives a call to start the compressor.

### Compressor Minimum On Delay

The compressor minimum on delay will ensure that the compressor output(s) are enabled for a minimum of (2) minute each time the compressor output is enabled. This will apply in every instance except in the event the high-pressure switch is tripped or emergency shutdown, then the compressor output will be disabled immediately.

### Compressor Short Cycle Delay Time

The compressor short cycle time delay will ensure that the compressor output will not be enabled for a minimum of five (5) minutes after it is disabled. This allows for the system refrigerant pressures to equalize after the compressor is disabled.

### Compressor Lead/Lag

Compressor lead/lag is a standard part of the FX10 control system. The unit is shipped from the factory with lead/lag enabled. Lead/lag can be deactivated through the unit mounted user interface. Lead/lag will always start the compressor with the least amount of run time and stop the compressor with the longest run time.

### Heating Cycle

During the heating cycle, the reversing valves will be positioned for heating operation. The thermostat or aquastat will command the reversing valves "Off" for heating. If the compressor short cycle time delay has been satisfied, the lead compressor will turn on after the accessory output has been enabled, the low pressure switches have been verified, and the fixed compressor start delay timer has been satisfied. When heating is no longer required, the compressor will be turned off immediately after the compressor minimum on delay has been satisfied. After the compressor output is turned off, it will remain off for the time specified in the compressor short cycle time delay. If the first stage compressor is not able to satisfy the heating demand, the second stage compressor will be activated by the thermostat or aquastat. The controller is allowed to operate the heat pump in the heating mode regardless of the outdoor air temperature.

### Cooling Cycle

During the cooling cycle, the reversing valves will be positioned for cooling operation. The thermostat or aquastat will command the reversing valves "On" for cooling. If the compressor short cycle time delay has been satisfied, the lead compressor will turn on after the accessory output has been enabled, the low pressure switches have been verified, and the fixed compressor start delay timer has been satisfied. When cooling is no longer required, the compressor will be turned off immediately after the compressor minimum on delay has been satisfied. After the compressor output is turned off, it will remain off for the time specified in the compressor short cycle time delay. If the first stage compressor is not able to satisfy the cooling demand, the second stage compressor will be activated by the thermostat or aquastat. The controller is allowed to operate the heat pump in the cooling mode regardless of the outdoor air temperature.

## Inputs and Outputs Configuration

<b>DUAL STAGE WW</b>			
<b>Input Name</b>	<b>Input</b>	<b>Output Name</b>	<b>Output</b>
Entering Load Water Temperature	AI 1	Compressor 1	DO1
Leaving Load Water Temperature 1	AI 2	Compressor 2	DO2
Source Heating Freeze Detection 1	AI 3	Reversing Valve	DO3
Source Heating Freeze Detection 2	AI 4	Accessory	DO4
Load Cooling Freeze Detection 1	AI 5	Compressor 1 Alarm	DO5
Load Cooling Freeze Detection 2	AI 6	Compressor 2 Alarm	DO6
		Network Output	DO7
Load Flow Proving Switch	DI 1	Network Output	DO8
Emergency Shutdown	DI 2	Network Output	DO9
Stage 2 Low Pressure	DI 3		
Source Htg Freeze Detection Select - 30°F	DI 4	Future	PWM1
Load Htg Freeze Detection Select - 30°F	DI 5	Future	PWM2
Stage 1 Low Pressure	DI 6		
Thermostat Y1	DI 7		
Thermostat Y2	DI 8		
Thermostat B	DI 9		
Source Flow Proving Switch	D10		
Stage 1 High Pressure	DI11		
Stage 2 High Pressure	DI12		
<b>XP10 Expansion Card</b>			
<b>Input Name</b>	<b>Input</b>	<b>Output Name</b>	<b>Output</b>
Entering Source Water Temperature	AI 1	Unused	DO 1
Leaving Source Water Temperature 1	AI 2	Unused	DO 2
Current Switch 1 - Compressor 1	AI 3	Unused	DO 3
Current Switch 2 - Compressor 2	AI 4	Unused	DO 4

## Unit Display and Interface

The Unit Display allows the user to view entering and leaving water temperatures, freeze detection readings, inputs and outputs, and allows the user enable and disable certain control functions through the various menus. The interface also displays all faults on the LCD once the unit has locked out to aid in diagnostics.

There are 10 LED indicator lights that indicate the following:

- Power - Shows that the FX processor is operational
- ⚠ Alarm - Lights when there is a lock-out or faulty freeze detection sensor
- 1 - Flashing shows Compressor 1 is running
- 2 - Flashing shows Compressor 2 is running
- 3 - On shows Compressor 2 is lead
- 4 - On shows Reversing valve in cool
- 8 - On shows unit in 'Test' mode

**Figure 5 - Unit Display/Interface**

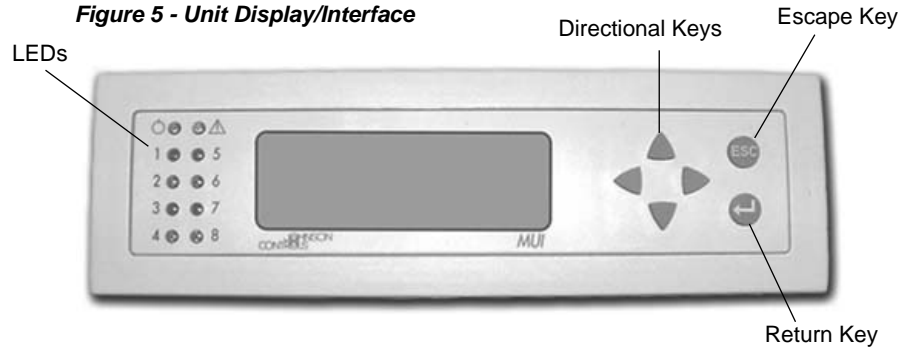

# Unit Display and Interface cont.

## MUI Menu Navigation

Welcome

Info Temp Stat Outputs Settings Maint Alarm\_History

**Info**

Dual Stage
Water-to-Water
PRODCWWE-08B
MM/DD/YY

**Temp**

Temperatures

Enter Load	77.2°F
Leave Load	51.0°F
Enter Source	70.0°F
Leave Source	66.0°F
Source Frz1	77.8°F
Source Frz2	30.0°F
Load Frz1	30.0°F
Load Frz2	30.0°F
Src Frz Setpt	30.0°F
LD Frz Setpt	30.0°F

**Stat**

Status

Unit Status	Auto
Y1 Status	OFF
Y2 Status	OFF
O Status	OFF
Emerg Shutdown	OFF
Current Sens1	OFF
Current Sens2	OFF
Load Flow	OFF
Src Flow	OFF
Low Pres1	ON
Hi Pres1	OFF
Low Pres2	ON
Hi Pres2	ON
Comp1 Low Limit	NML
Comp2 Low Limit	NML

**Outputs**

Outputs

Comp1 Status	ON
Comp2 Status	OFF
Acc1 Status	OFF
Stg1 Status	Normal
Stg2 Status	Normal
BO7	OFF
BO8	OFF
BO9	OFF
EXPB01	OFF
EXPB02	OFF
EXPB07	OFF
EXPB08	OFF

**Settings**

Settings

Unit of Measure	F
-----------------	---

**Maint**

Maintenance

Y1 Input	Auto
Y2 Input	Auto
O Input	Auto
Emerg SD	Auto
Acc1 Sel	ON Comp
Lead/Lag Select	OFF
Low Frz Setpt	15°F
Hi Frz Setpt	33°F
Acc1 Dly	9 S

**Alarm**

ALARM SUMMARY

^/High Pressure
-----------------

**Alarm lock-outs** are reset by cycling power, by pressing the “ESC” and Return  keys simultaneously for a minimum of 15 seconds.

**Test mode** is enabled by holding the ‘Esc’ and Down Arrow simultaneously for a minimum of 15 seconds and releasing. Test mode times out after 30 minutes, and may also be ended by pressing ‘ESC’ and Up Arrow simultaneously and releasing. Test Mode bypasses the On Delay (90 sec) and Random Start timers for quicker troubleshooting. It also allows cycling the reversing valve without compressor shutdown.

## Unit Display and Interface cont.

### Menu and Menu Contents

#### Alarm

- Displays unit alarms until the unit has been reset (Unit alarms can be reset by holding both the Escape (ESC) key and Return (←) key for five seconds or by power cycling the unit.)

#### Alarm History

If a fault occurs the fault will be recorded in history viewable on the unit mounted display. Each fault type will be displayed in the history menu with a number between 0 and 3. A reading of 3+ means that the fault has occurred more than 3 times in the past. The history menu can be cleared with a power cycle only. Alarm date and time are not included in the history.

#### Unit Alarms

Unit alarms are shown on the display once the unit has locked out.

#### Load Flow – Load Flow Switch is Not Closed

- The load flow switch must be closed prior to either compressor starting and must remain closed for the entire run time of the compressor(s).

#### Low Pressure 1 – Compressor Circuit 1 Low Pressure Switch

- The low pressure switch is checked before compressor start up and is monitored during compressor operation.

#### Src FP 1 Temp Low – Source Freeze Detection Sensor 1

- The source freeze detection sensor on compressor circuit 1 has reached its setpoint.

#### Src FP 1 Sensor Bad

- The sensor for source freeze detection on compressor circuit 1 is unreliable or is not reading.

#### LD FP 1 Temp Low – Load Freeze Detection Sensor 1

- The load freeze detection sensor on compressor circuit 1 has reached its setpoint.

#### LD FP 1 Sensor Bad

- The sensor for load freeze detection on compressor circuit 1 is unreliable or is not reading.

#### Source Flow – Source Flow Switch is Not Closed

- The source flow switch must be closed prior to either compressor starting and must remain closed for the entire run-time of the compressor(s).

#### High Pressure 1 – Compressor Circuit 1 High Pressure Switch

- If high pressure switch 1 opens at any time during compressor 1 run time the compressor will be shut down immediately.

#### Low Pressure 2 - Compressor Circuit 2 Low Pressure Switch

- The low pressure switch is checked before compressor start up and is monitored during compressor operation.

#### Src FP 2 Temp Low - Source Freeze Detection Sensor 2

- The source freeze detection sensor on compressor circuit 2 has reached its setpoint.

#### Src FP 2 Sensor Bad

- The sensor for source freeze detection on compressor circuit 2 is unreliable or is not reading.

#### LD FP 2 Temp Low - Load Freeze Detection Sensor 2

- The load freeze detection sensor on compressor circuit 2 has reached its setpoint.

#### LD FP 2 Sensor Bad

- The sensor for load freeze detection on compressor circuit 2 is unreliable or is not reading.

#### High Pressure 2 - Compressor Circuit 2 High Pressure Switch

- If high pressure switch 2 opens at any time during compressor 2 run time the compressor will be shut down immediately.

#### Comp Start Failure – Compressor Start Failure

- If either compressor fails to start when the contactor pulls in the compressor current switch will cause that compressor to be locked out after 2 retries. The other compressor will continue to operate normally in this condition.



## Reference Calculations

Heating Calculations: $\text{LWT} = \text{EWT} - \frac{\text{HE}}{\text{GPM} \times 500^*}$	Cooling Calculations: $\text{LWT} = \text{EWT} + \frac{\text{HR}}{\text{GPM} \times 500^*}$
--	--

**NOTE:** \* When using water. Use 485 for 15% methanol/water or Environol solution.

## Legend

### Abbreviations and Definitions

ELT	= entering load fluid temperature to heat pump	PSI	= pressure drop in pounds per square inch
LLT	= leaving load fluid temperature from heat pump	FT HD	= pressure drop in feet of head
LGPM	= load flow in gallons per minute	KW	= kilowatt
LWPD	= load heat exchanger water pressure drop	HR	= heat rejected in MBTUH
EST	= entering source fluid temperature to heat pump	TC	= total cooling capacity in MBTUH
LST	= leaving source fluid temperature from heat pump	COP	= coefficient of performance (HC/KW x 3.413)
SGPM	= source flow in gallons per minute	HC	= heating capacity in MBTUH
SWPD	= source heat exchanger water pressure drop	HE	= heat of extraction in MBTUH
EER	= cooling energy efficiency (TC/KW)		

## Unit Startup

---

### Verify the following:

- High voltage is correct and matches nameplate
- Fuses, breakers and wire size are correct
- Low voltage wiring is complete
- Piping is complete and the water system has been cleaned and flushed
- Air is purged from closed loop system
- Isolation valves are open and water control valves or loop pumps are wired
- Service/access panels are in place
- Transformer has been switched to lower voltage tap if needed (208/230 volt units only)
- Unit controls are in "off" position
- Flow switches are installed and ready
- Freeze detection setpoints have been set in the microprocessor



**WARNING: Verify ALL water controls are open and allow water flow PRIOR to engaging the compressor. Failure to do so can result in freezing the heat exchanger or water lines causing permanent damage to the unit.**

### Startup Steps

- Set thermostat control above cooling setpoint.
- Set thermostat control in cooling mode.
- Slowly reduce the control setting until both the compressor and water control valve/loop pumps are activated. Verify that the compressor is on and that the water flow rate is correct by measuring pressure drop through the heat exchanger and comparing to the Pressure Drop table. Check for correct rotation of scroll compressors. Switch any two power leads at the L1, L2, and L3 line voltage termination block if incorrect.
- Perform a cooling capacity test by multiplying GPM x  $\Delta T$  x 485 (antifreeze/water). Use 500 for 100% water. Check capacity against catalog data at same conditions.
- Set control to "OFF" position.
- Leave unit "OFF" for approximately five (5) minutes to allow pressure to equalize.
- Adjust control below heating setpoint.
- Set control in "HEAT" position mode.
- Slowly increase the control setting until both compressor and water control valve/loop pumps are activated. The reversing valve should be heard changing over.
- Perform a heating capacity test by multiplying GPM x  $\Delta T$  x 485 (antifreeze/water). Use 500 for 100% water. Check capacity against catalog data at same conditions.
- Check for vibrations, noise and water leaks.
- Set system to maintain desired setpoint.
- Instruct the owner/operator of correct control and system operation.

## Operating Parameters

### Heating Mode

Entering Load Temp (°F)	Entering Source Temp (°F)	Suction Pressure (psig)	Discharge Pressure (psig)	Superheat (°F)	Subcooling (°F)
60	30	75-100	200-215	10-12	10-13
	50	100-125	200-215	12-14	8-12
	70	125-150	215-230	14-18	8-12
	90	150-165	230-255	25-30	8-12
80	30	75-100	285-300	10-12	10-13
	50	100-125	300-315	12-14	8-12
	70	125-150	315-330	14-18	8-12
	90	150-165	330-345	25-30	8-12
100	30	85-110	365-380	10-12	7-11
	50	110-135	385-400	12-14	7-11
	70	135-165	400-415	14-18	3-7
120	50	110-135	485-500	12-14	7-11
	70	135-165	500-515	14-18	3-7

NOTE: Operating data based on normal conditions with 3 gpm/ton for the load and source.

2/15/10

### Cooling Mode

Entering Load Temp (°F)	Entering Source Temp (°F)	Suction Pressure (psig)	Discharge Pressure (psig)	Superheat (°F)	Subcooling (°F)
50	30	80-90	140-175	15-20	3-6
	50	90-100	200-235	11-15	6-9
	70	100-110	250-285	11-15	9-12
	90	100-120	330-365	8-12	12-14
	110	110-130	430-465	8-12	14-19
70	30	80-90	150-185	15-20	3-6
	50	90-100	210-245	11-15	6-9
	70	100-110	260-295	11-15	9-12
	90	110-120	340-375	8-12	12-14
90	110	110-140	440-485	8-12	14-19
	30	80-90	150-185	15-20	3-6
	50	90-100	210-245	11-15	6-9
	70	100-110	260-295	11-15	9-12
110	90	110-120	340-375	8-12	12-14
	30	90-100	160-195	40-45	3-6
	50	110-130	220-255	30-40	6-9

NOTE: Operating data based on normal conditions with 3 gpm/ton for the load and source.

2/15/10

## Load and Source Pressure Drop

Model	GPM	Pressure Drop (psi)				
		30°F	50°F	70°F	90°F	110°F
100	15	1.0	0.8	0.5	0.3	0.1
	23	2.5	2.2	2.0	1.7	1.3
	30	3.8	3.6	3.3	3.1	2.4
	34	4.5	4.3	4.0	3.8	3.0
120	18	1.6	1.3	1.1	0.8	0.6
	28	3.4	3.2	2.9	2.7	2.1
	36	4.9	4.7	4.4	4.2	3.3
	40	5.6	5.4	5.1	4.9	3.9
150	21	2.1	1.9	1.6	1.4	1.0
	32	4.2	3.9	3.7	3.4	2.7
	42	6.0	5.8	5.5	5.3	4.2
	50	7.5	7.3	7.0	6.8	5.5
180	24	2.7	2.4	2.2	1.9	1.5
	36	4.9	4.7	4.4	4.2	3.3
	48	7.1	6.9	6.6	6.4	5.1
	60	9.3	9.1	8.8	8.6	7.0

3/9/09

## Thermistor and Compressor Resistance

Thermistor Temperature		Resistance in Ohms
°F	°C	
5	-15	758
14	-10	789
23	-5	822
32	0	855
41	5	889
50	10	924
59	15	960
68	20	997
77	25	1035
86	30	1074
95	35	1113
104	40	1153
113	45	1195
122	50	1237
131	55	1279
140	60	1323
149	65	1368
158	70	1413
167	75	1459
176	80	1506
185	85	1554
194	90	1602
203	95	1652
212	100	1702

2/15/10

Model	208-230/60/1		208-230/60/3	460/60/3	575/60/3
	Run	Start			
100	0.32	0.821	0.610	2.330	4.060
120	0.28	0.819	0.610	2.330	4.060
150	0.291	0.841	0.422	2.200	3.289
180	0.312	0.874	0.419	1.614	2.507

NOTE: Resistance values may vary ±7%.

2/15/10

## Heat of Extraction/Rejection Data

Model	Source gpm	Load gpm	EST °F	Heat of Extraction (HE)				Heat of Rejection (HR)			
				60°F	80°F	100°F	120°F	50°F	70°F	90°F	110°F
100	30	30	30	83.6	75.4	67.3	59.1	131.6	142.8	154.1	165.3
			50	1015.1	96.9	88.7	80.4	127.3	140.0	152.6	165.2
			70	126.7	118.3	110.0	101.7	123.1	137.1	151.2	N/A
			90	148.2	139.8	N/A	N/A	118.9	134.3	149.7	N/A
			110	Not Available				114.6	131.5	N/A	N/A
120	36	36	30	90.9	81.9	72.8	63.8	159.6	177.7	195.8	213.9
			50	115.2	106.2	97.2	88.2	157.1	175.4	193.7	212.0
			70	139.6	130.6	121.6	112.5	154.5	173.1	191.6	N/A
			90	164.0	154.9	N/A	N/A	152.0	170.7	189.5	N/A
			110	Not Available				149.4	168.4	N/A	N/A
150	42	42	30	112.4	95.6	78.8	62.0	206.4	246.9	287.4	327.9
			50	147.0	130.4	113.8	97.1	196.6	236.6	276.6	316.6
			70	181.6	165.2	148.7	132.3	186.7	226.2	265.8	N/A
			90	216.3	200.0	N/A	N/A	176.8	215.9	255.0	N/A
			110	Not Available				166.9	205.6	N/A	N/A
180	48	48	30	126.2	108.7	91.1	73.6	233.8	282.2	330.6	379.0
			50	166.3	146.9	127.4	108.0	224.3	267.6	310.9	354.2
			70	206.4	185.0	163.7	142.4	214.8	253.0	291.2	N/A
			90	246.5	223.2	N/A	N/A	205.2	238.3	271.4	N/A
			110	Not Available				195.7	223.7	N/A	N/A

3/7/13

## Heating Cycle Analysis

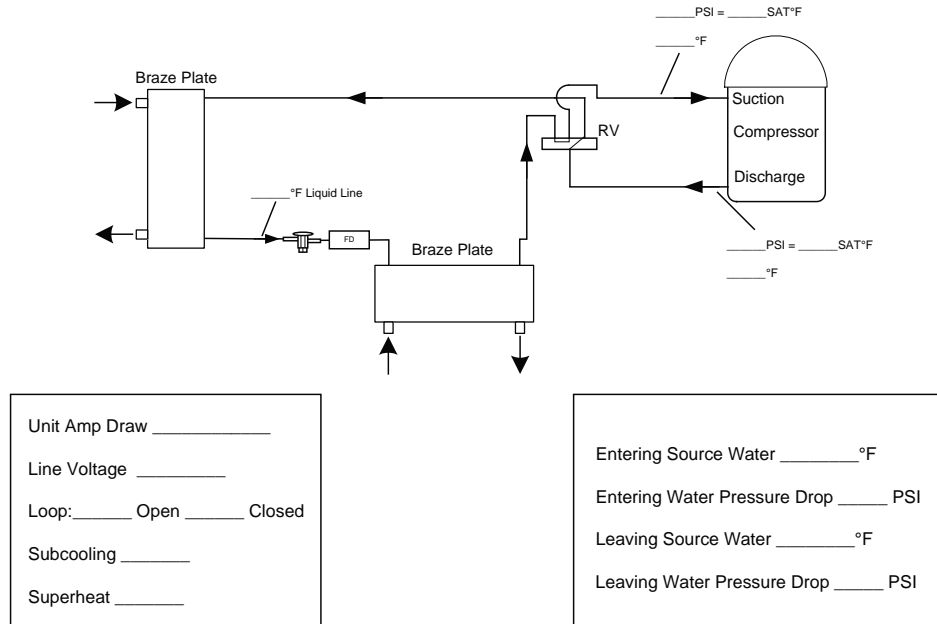

NOTE: Do not attach refrigerant gauges unless a problem is suspected!

## Cooling Cycle Analysis

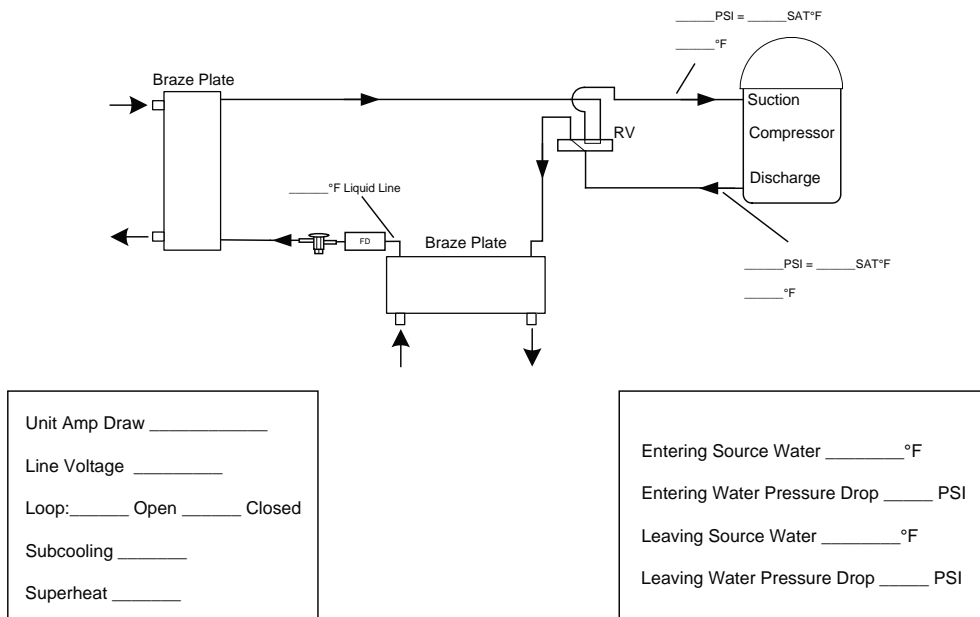

NOTE: Do not attach refrigerant gauges unless a problem is suspected!

# Startup and Troubleshooting Form

Company Name: \_\_\_\_\_ Company Phone No: \_\_\_\_\_  
 Technician Name: \_\_\_\_\_ Date: \_\_\_\_\_  
 Model No: \_\_\_\_\_ Serial No: \_\_\_\_\_  
 Owner's Name: \_\_\_\_\_ Open or Closed Loop: \_\_\_\_\_  
 Installation Address: \_\_\_\_\_ Installation Date: \_\_\_\_\_

Check One

Start up/Check-out for new installation     Troubleshooting    Problem: \_\_\_\_\_

1. FLOW RATE IN GPM (SOURCE SIDE HEAT EXCHANGER)

Water In Pressure: a. \_\_\_\_\_ PSI  
 Water Out Pressure: b. \_\_\_\_\_ PSI  
 Pressure Drop = a - b c. \_\_\_\_\_ PSI  
 Convert Pressure Drop to Flow Rate  
 (refer to *Pressure Drop* table) d. \_\_\_\_\_ GPM

2. TEMPERATURE RISE OR DROP ACROSS SOURCE SIDE HEAT EXCHANGER

	COOLING	HEATING
Water In Temperature:	e. _____ °F	e. _____ °F
Water Out Temperature:	f. _____ °F	f. _____ °F
Temperature Difference:	g. _____ °F	g. _____ °F

3. TEMPERATURE RISE OR DROP ACROSS LOAD SIDE HEAT EXCHANGER

	COOLING	HEATING
Water In Temperature:	h. _____ °F	h. _____ °F
Water Out Temperature:	i. _____ °F	i. _____ °F
Temperature Difference:	j. _____ °F	j. _____ °F

4. HEAT OF REJECTION (HR) / HEAT OF EXTRACTION (HE) CALCULATION

HR or HE = Flow Rate x Temperature Difference x Brine Factor\*  
 d. (above) x g. (above) x 485 for Methanol or Environol, 500 for water\*  
 Heat of Extraction (Heating Mode) = \_\_\_\_\_ btu/hr  
 Heat of Rejection (Cooling Mode) = \_\_\_\_\_ btu/hr  
 Compare results to Capacity Data Tables

Note: Steps 5 through 8 need only be completed if a problem is suspected

5. WATTS

	COOLING	HEATING	HYDRONIC
Volts:	m. _____ VOLTS	m. _____ VOLTS	m. _____ VOLTS
Total Amps (Comp. + Fan):	n. _____ AMPS	n. _____ AMPS	n. _____ AMPS
Watts = m. x n. x 0.85	o. _____ WATTS	o. _____ WATTS	o. _____ WATTS

6. CAPACITY

Cooling Capacity = HR. - (o. x 3.413)                      p. \_\_\_\_\_ btu/hr  
 Heating Capacity= HE. + (o. x 3.413)                      p. \_\_\_\_\_ btu/hr

7. EFFICIENCY

Cooling EER = p. / o.    q. \_\_\_\_\_ EER  
 Heating COP = p. / (o. x 3.413)                              q. \_\_\_\_\_ COP

8. SUPERHEAT (S.H.) / SUBCOOLING (S.C.)

	COOLING	HEATING	HYDRONIC
Suction Pressure:	r. _____ PSI	r. _____ PSI	r. _____ PSI
Suction Saturation Temperature:	s. _____ °F	s. _____ °F	s. _____ °F
Suction Line Temperature:	t. _____ °F	t. _____ °F	t. _____ °F
Superheat = t. - s.	u. _____ °F	u. _____ °F	u. _____ °F
Head Pressure:	v. _____ PSI	v. _____ PSI	v. _____ PSI
High Pressure Saturation Temp.:	w. _____ °F	w. _____ °F	w. _____ °F
Liquid Line Temperature*:	x. _____ °F	x. _____ °F	x. _____ °F
Subcooling = w. - x.	y. _____ °F	y. _____ °F	y. _____ °F

\* Note: Liquid line is between the source heat exchanger and the expansion valve in the cooling mode;  
 between the load heat exchanger and the expansion valve in the heating mode.

## Troubleshooting

---

Should a major problem develop, refer to the following information for possible causes and corrective steps.

### If compressor won't run:

1. The fuse may be open or the circuit breaker is tripped. Check electrical circuits and motor windings for shorts or grounds. Investigate for possible overloading. Replace fuse or reset circuit breakers after fault is corrected.
2. Supply voltage may be too low. Check it with a volt meter.
3. Control system may be faulty. Check control for correct wiring of thermostat or aquastat and check the 24 volt transformer for proper voltage.
4. Wires may be loose or broken. Replace or tighten.
5. The low pressure switch may have tripped due to one or more of the following:
  - a) Heating
    - 1) Plugged heat exchanger on source side
    - 2) Water flow source side - (Low)
    - 3) Water too cold source side
    - 4) Low refrigerant
  - b) Cooling
    - 1) Plugged heat exchanger on load side
    - 2) Water flow load side - (Low)
    - 3) Water too cold load side
    - 4) Low refrigerant
6. The high pressure switch may have tripped due to one or more of the following:
  - a) Heating
    - 1) Plugged heat exchanger on load side
    - 2) Low water flow load side
    - 3) Water too warm load side
  - b) Cooling
    - 1) Plugged heat exchanger on source side
    - 2) Low water flow on source side
    - 3) Water too warm source side
7. The compressor overload protection may be open.
8. The internal winding of the compressor motor may be grounded to the compressor shell. If so, replace the compressor.
9. The compressor winding may be open or shorted. Disconnect power. Check continuity with ohm meter. If the winding is open, replace the compressor.

### If sufficient cooling or heating is not obtained:

1. Check control for improper location or setting.
2. Check for restriction in water flow.
3. Check refrigerant subcooling and superheat for proper refrigerant charge and expansion valve operation.
4. The reversing valve may be defective and creating a bypass of refrigerant. If the unit will not heat, check the reversing valve coil.

### If the unit operation is noisy:

1. Check compressor for loosened mounting bolts. Make sure compressor is floating free on its isolator mounts. Check for tubing contact with the compressor or other surfaces. Readjust it by bending slightly.
2. Check screws on all panels.
3. Check for chattering or humming in the contactor or relays due to low voltage or a defective holding coil. Replace the component.
4. Check for proper installation of vibration absorbing material under the unit.
5. Check for abnormally high discharge pressures.
6. Compressor rotation incorrect

## Preventive Maintenance

---

### Unit Heat Exchanger Maintenance

1. Keep all air out of the water or antifreeze solution.
2. Keep the system under pressure at all times. Closed loop systems must have positive static pressure or air vents may draw air into the system.

**NOTES:** If the installation is in an area with a known high mineral content in the water, it is best to establish with the owner a periodic maintenance schedule for checking the water-to-refrigerant heat exchanger on a regular basis. Should periodic cleaning be necessary, use standard cleaning procedures. Generally, the more water flowing through the unit, the less chance there is for scaling. Low GPM flow rates produce higher temperatures through the heat exchanger. To avoid excessive pressure drop and the possibility of metal erosion, do not exceed GPM flow rate as shown on the specification sheets for each unit.

### Replacement Procedures

When contacting the company for service or replacement parts, refer to the model number and serial number of the unit as stamped on the serial plate attached to the unit. If replacement parts are required, mention the date of installation of the unit and the date of failure, along with an explanation of the malfunctions and a description of the replacement parts required.

### In-Warranty Material Return

Material may not be returned except by permission of authorized warranty personnel. Contact your local distributor for warranty return authorization and assistance.



# Service Parts List

Part Description		100				120			
		208-230/60/1	208-230/60/3	460/60/3	575/60/3	208-230/60/3	208-230/60/3	460/60/3	575/60/3
Refrigeration Components	Compressor	34P580-01	34P580-03	34P580-04	34P580-05	34P616-01	34P616-03	34P616-04	34P616-05
	Compressor Sound Jacket	92P504A05				92P519-02			
	Thermal Expansion Valve	33P608-18				33P605-12			
	Filter Dryer	36P500B02				36P500B02			
	Reversing Valve with Coil	33P526-04				33P526-04			
	Brazed Plate Heat Exchanger	62P565-01				62P565-01			
	Heat Exchanger Support Bracket	47F588-01				47F588-01			
Safeties / Sensors	High Pressure Switch	35P506B02				35P506B02			
	Low Pressure Switch	35P506B01				35P506B01			
	Water Temperature Sensor	12P529-04				12P529-04			
	Low Water Coil Temp Sensor	12S529-01				12S529-01			
Electrical	Compressor Contactor	13P004A03	13P537B03			13P004A03	13P537B03		
	Transformer	15P501B01		15P505B01	15P506B01	15P501B01		15P505B01	15P506B01
	Power In Terminal Block	12P524A01				12P524A01			
	Connection Block - Small	12P503-06				12P503-06			
	Connection Block - Low Voltage	12P520-01				12P520-01			
	Grounding Lug	12P004A				12P004A			
Control	FX10 Main Board - no communications	17X51606-09				17X51606-09			
	FX10 Main Board & N2 Open Com Card	17X51606-10				17X51606-10			
	FX10 Main Board & Lonworks Com Card	17X51606-12				17X51606-12			
	FX10 Main Board & BACnet Com Card	17X51606-11				17X51606-11			
	FX10 Expansion Board	17P516-07				17P516-07			
	Display	19P563-01				19P563-01			
	FX10 Display Interface Board	17P516-11				17P516-11			
Cabinet	Side Access Panel	40C661-01				40C661-01			
	Front/Back Access Panel	40C662-01				40C662-01			
	Top Panel (back mount)	42C547-01				42C547-01			
	Top Panel - Large (top mount)	42C547-02				42C547-02			
	Top Panel - Small (top mount)	42C547-03				42C547-03			

5/6/09

Part Description		150				180			
		208-230/60/3	208-230/60/3	460/60/3	575/60/3	208-230/60/3	208-230/60/3	460/60/3	575/60/3
Refrigeration Components	Compressor	34P614-01	34P614-03	34P614-04	34P614-05	34P609-01	34P605-03	34P605-04	34P605-05
	Compressor Sound Jacket	92P519-02				92P519-02			
	Thermal Expansion Valve	33P605-13				33P605-14			
	Filter Dryer	36P500B02				36P500B02			
	Reversing Valve with Coil	33P526-04				33P526-04			
	Brazed Plate Heat Exchanger	62P565-01				62P565-01			
	Heat Exchanger Support Bracket	47F588-01				47F588-01			
Safeties / Sensors	High Pressure Switch	35P506B02				35P506B02			
	Low Pressure Switch	35P506B01				35P506B01			
	Water Temperature Sensor	12P529-04				12P529-04			
	Low Water Coil Temp Sensor	12S529-01				12S529-01			
Electrical	Compressor Contactor	13P004A03	13P537B03			13P004A03	13P537B03		
	Transformer	15P501B01		15P505B01	15P506B01	15P501B01		15P505B01	15P506B01
	Power In Terminal Block	12P524A01				12P524A01			
	Connection Block - Small	12P503-06				12P503-06			
	Connection Block - Low Voltage	12P520-01				12P520-01			
	Grounding Lug	12P004A				12P004A			
Control	FX10 Main Board - no communications	17X51606-09				17X51606-09			
	FX10 Main Board & N2 Open Com Card	17X51606-10				17X51606-10			
	FX10 Main Board & Lonworks Com Card	17X51606-12				17X51606-12			
	FX10 Main Board & BACnet Com Card	17X51606-11				17X51606-11			
	FX10 Expansion Board	17P516-07				17P516-07			
	Display	19P563-01				19P563-01			
	FX10 Display Interface Board	17P516-11				17P516-11			
Cabinet	Side Access Panel	40C661-01				40C661-01			
	Front/Back Access Panel	40C662-01				40C662-01			
	Top Panel (back mount)	42C547-01				42C547-01			
	Top Panel - Large (top mount)	42C547-02				42C547-02			
	Top Panel - Small (top mount)	42C547-03				42C547-03			

5/6/09

## Revision Guide

---

<b>Pages:</b>	<b>Description:</b>	<b>Date:</b>	<b>By:</b>
All	First Published	21 May 2014	DS





Product: **Affinity Series**  
Type: Geothermal Hydronic Heat Pumps  
Size: 8-15 Ton Dual Capacity

Document Type: Installation Manual  
Part Number: IM1057WK6  
Release Date: 05/14