



Heating and Air Conditioning

***SUBMITTAL SET***

**AFFINITY YDL SERIES  
COMMERCIAL GEOTHERMAL/  
WATER SOURCE HEAT PUMPS  
SINGLE AND DUAL CAPACITY**

**MODELS:**

**HORIZONTAL: YDL084-180  
(7-15 NOMINAL TONS)**

**VERTICAL: YDL084-360  
(7-30 NOMINAL TONS)**



Due to continuous product improvement, specifications are subject to change without notice.

Visit us on the web at [www.yorkgeothermal.com](http://www.yorkgeothermal.com)

Additional rating information can found at [www.ahrirectory.org](http://www.ahrirectory.org)

FOR DISTRIBUTION USE ONLY - NOT TO BE USED AT POINT OF RETAIL SALE

Contractor: \_\_\_\_\_ P.O.: \_\_\_\_\_

Engineer: \_\_\_\_\_

Project Name: \_\_\_\_\_ Unit Tag: \_\_\_\_\_

**Affinity YDL Series**  
**Single Capacity**  
**7 - 30 Tons 60Hz**



## Model Nomenclature

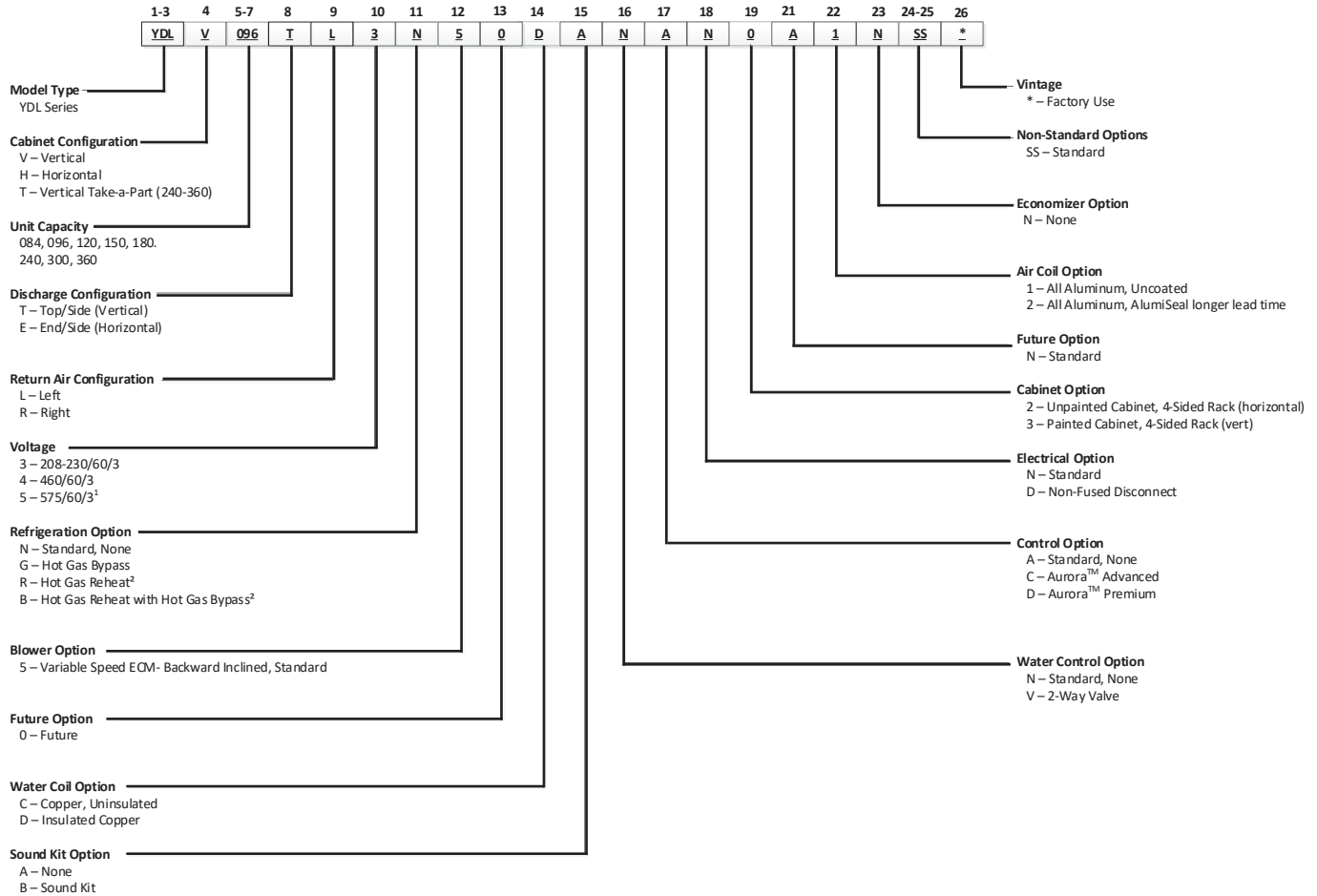

Note:  
 1- 575V option requires a power transformer.  
 2- Not available on H180  
 \* Flow meter extremely mounted.  
 \*\* EVV only available with Premium Controls

## Electrical Availability

Voltage	Dual Capacity Compressor		
	084	096	120
208-230/60/3	•	•	•
460/60/3	•	•	•
575/60/3	•	•	•

Voltage	Two Compressor				
	150	180	240	300	360
208-230/60/3	•	•	•	•	•
460/60/3	•	•	•	•	•
575/60/3	•	•	•	•	•

• - Available 3/30/21

The manufacturer works continually to improve its products. As a result, the design and specifications of each product at the time of order may be changed without notice. Purchaser's approval of this data set signifies that the equipment is acceptable under the provisions of the job specification. Statements and other information contained herein are not express warranties and do not form the basis of any bargain between the parties, but are merely the manufacturer's opinion or commendation of its products. York and Affinity are registered trademarks of Johnson Controls, Inc., and are used with permission.

Contractor: \_\_\_\_\_ P.O.: \_\_\_\_\_

Engineer: \_\_\_\_\_

Project Name: \_\_\_\_\_ Unit Tag: \_\_\_\_\_



## AHRI Data

### AHRI/ASHRAE/ISO 13256-1 (Vertical) English (IP) Units

Model	Capacity Modulation	Flow Rate		Water Loop Heat Pump				Ground Water Heat Pump				Ground Loop Heat Pump			
				Cooling EWT 86°F		Heating EWT 68°F		Cooling EWT 59°F		Heating EWT 50°F		Cooling Brine Full Load 77°F Part Load 68°F		Heating Brine Full Load 32°F Part Load 41°F	
		gpm	cfm	Capacity Btuh	EER Btuh/W	Capacity Btuh	COP	Capacity Btuh	EER Btuh/W	Capacity Btuh	COP	Capacity Btuh	EER Btuh/W	Capacity Btuh	COP
084	Full	21	2500	86,000	16.0	103,600	5.0	98,000	24.0	84,000	4.4	90,000	18.5	67,000	3.8
	Part	14	1750	58,000	17.0	65,000	5.2	67,000	31.0	54,000	4.5	64,000	25.0	48,500	4.0
096	Full	24	2800	95,000	15.3	120,000	5.0	106,000	22.0	96,000	4.4	98,000	17.0	76,000	3.8
	Part	16	1900	63,000	16.4	75,000	5.2	73,000	28.5	60,000	4.5	69,000	23.5	53,000	4.0
120	Full	30	3600	119,000	14.5	140,000	5.0	135,000	21.0	114,000	4.2	123,000	16.5	89,000	3.5
	Part	20	2400	76,000	15.2	86,500	5.1	91,000	26.0	70,000	4.3	85,000	22.0	58,000	3.6
150	Full	36	4500	150,000	15.6	160,000	4.6	165,000	22.0	130,000	4.1	156,000	17.3	105,000	3.2
	Part	18	2300	75,000	16.0	80,000	5.0	82,500	23.0	65,000	4.5	78,000	19.0	52,500	4.0
180	Full	45	5200	180,000	14.0	195,000	4.3	190,000	18.0	162,000	3.8	184,000	15.2	128,000	3.2
	Part	28	2800	87,000	15.0	91,500	4.6	95,000	21.0	75,000	4.0	93,000	18.5	66,000	3.6
240	Full	60	7500	240,000	16.0	285,000	5.0	275,000	23.5	228,000	4.4	252,000	18.2	190,000	3.8
	Part	35	5400	130,000	17.5	148,000	5.6	145,000	25.0	118,000	4.8	140,000	23.0	100,000	4.2
300	Full	75	9000	300,000	15.0	350,000	4.6	342,000	23.0	290,000	4.1	315,000	17.2	230,000	3.7
	Part	40	6500	150,000	17.0	175,000	5.0	171,000	24.0	145,000	4.5	157,500	18.0	115,000	4.0
360	Full	90	9900	350,000	12.1	400,000	4.0	400,000	17.0	340,000	3.8	355,000	14.0	270,000	3.3
	Part	45	7500	175,000	12.4	222,000	4.2	190,000	18.4	170,000	4.0	180,000	16.5	140,000	3.5

Cooling capacities based upon 80.6°F DB, 66.2°F WB entering air temperature

Heating capacities based upon 68°F DB, 59°F WB entering air temperature

3/30/21

All ratings based upon 208V operation

Models 084-120 are rated and certified in accordance with ISO/AHRI/ASHRAE 13256-1

Models 150-360 are rated in accordance with ISO/AHRI/ASHRAE 13256-1 but are not certified since their capacity exceeds the scope of the AHRI program.

### AHRI/ASHRAE/ISO 13256-1 (Horizontal) English (IP) Units

Model	Capacity Modulation	Flow Rate		Water Loop Heat Pump				Ground Water Heat Pump				Ground Loop Heat Pump			
				Cooling EWT 86°F		Heating EWT 68°F		Cooling EWT 59°F		Heating EWT 50°F		Cooling Brine Full Load 77°F Part Load 68°F		Heating Brine Full Load 32°F Part Load 41°F	
		gpm	cfm	Capacity Btuh	EER Btuh/W	Capacity Btuh	COP	Capacity Btuh	EER Btuh/W	Capacity Btuh	COP	Capacity Btuh	EER Btuh/W	Capacity Btuh	COP
H084	Full	21	2500	85,000	15.0	96,000	4.5	96,000	22.0	82,500	4.3	88,000	17.5	67,000	3.6
	Part	14	1750	57,500	16.0	65,000	5.1	66,500	29.0	54,000	4.4	64,000	24.0	48,500	4.0
H096	Full	24	2800	95,000	14.5	108,000	4.8	106,000	21.0	93,000	4.4	97,000	16.5	76,000	3.7
	Part	16	1900	63,000	16.0	74,000	5.0	73,000	28.0	60,000	4.3	69,000	23.0	53,000	3.9
H120	Full	30	3600	117,000	14.5	140,000	5.0	130,000	21.0	114,000	4.2	123,000	16.5	89,000	3.5
	Part	20	2400	76,000	15.2	86,500	5.0	90,000	26.0	70,000	4.3	85,000	22.0	58,000	3.6
H150	Full	36	4500	148,000	15.4	160,000	4.6	163,000	22.0	130,000	4.1	155,000	17.0	105,000	3.2
	Part	18	2300	74,000	15.5	80,000	4.9	81,000	23.0	65,000	4.3	76,000	18.0	52,500	4.0
H180	Full	45	5200	178,000	13.8	192,000	4.3	187,000	17.5	162,000	3.7	182,000	15.0	128,000	3.2
	Part	28	2800	85,000	14.8	90,000	4.5	94,000	20.0	75,000	4.0	91,000	18.0	66,000	3.6

Cooling capacities based upon 80.6°F DB, 66.2°F WB entering air temperature

Heating capacities based upon 68°F DB, 59°F WB entering air temperature

3/30/21

All ratings based upon 208V operation

Models 084-120 are rated and certified in accordance with ISO/AHRI/ASHRAE 13256-1

Models 150-360 are rated in accordance with ISO/AHRI/ASHRAE 13256-1 but are not certified since their capacity exceeds the scope of the AHRI program.



All Aston XL Series product is safety listed under UL1995 thru UL and performance tested in accordance with AHRI/ISO standard 13256-1.

The manufacturer works continually to improve its products. As a result, the design and specifications of each product at the time of order may be changed without notice. Purchaser's approval of this data set signifies that the equipment is acceptable under the provisions of the job specification. Statements and other information contained herein are not express warranties and do not form the basis of any bargain between the parties, but are merely the manufacturer's opinion or commendation of its products. York and Affinity are registered trademarks of Johnson Controls, Inc., and are used with permission.

Contractor: \_\_\_\_\_ P.O.: \_\_\_\_\_

Engineer: \_\_\_\_\_

Project Name: \_\_\_\_\_ Unit Tag: \_\_\_\_\_

**Affinity YDL Series**  
**Single Capacity**  
**7 - 30 Tons 60Hz**



## Dimensional Data

### LEFT RETURN SHOWN

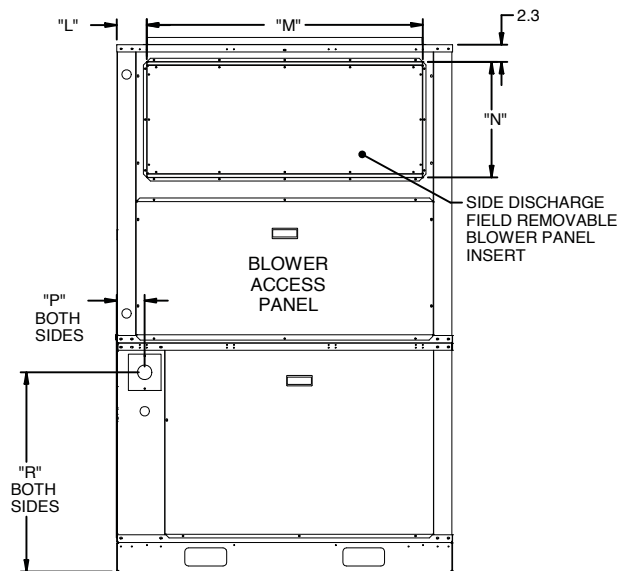
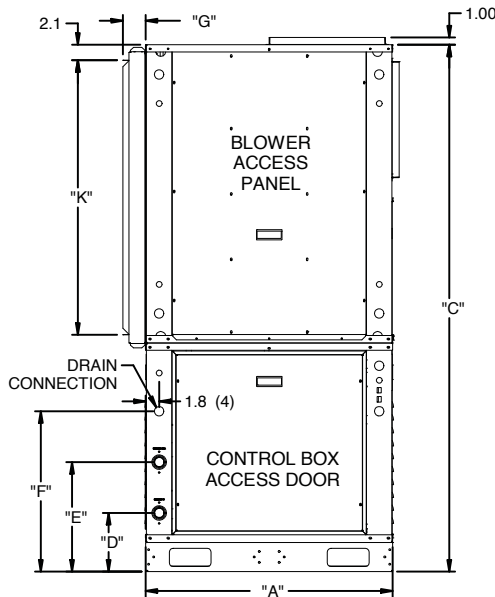
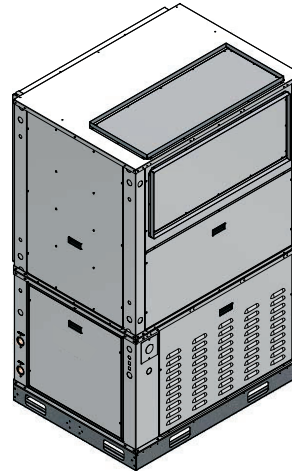
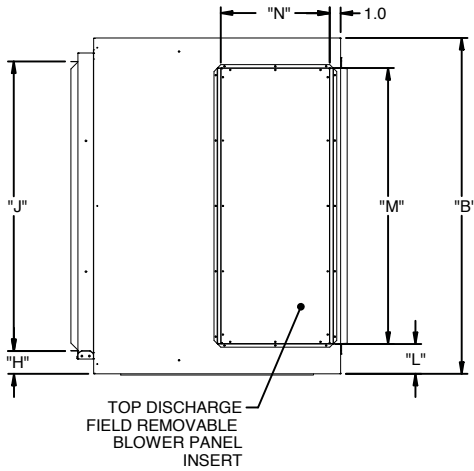

### Vertical Dimensional Data

Vertical Models	Overall Cabinet			Water Connections				Return Connection*				Discharge Connection			Electrical Connections		
	A	B	C	1	2	3	using deluxe filter rack				L	M	N	P	R		
	Width	Depth	Height	In	Out	Condensate	Water FPT	Filter Rack	From Edge	Return	Return	Return	From Edge	Supply Width	Supply Height	From Edge	Height
084-096	in.	34.0	36.3	72.5	8.1	15.1	22.1	1 1/4"	3.1	3.2	29.9	37.8	4.1	28.0	16.0	3.9	27.4
	cm.	86.4	92.2	184.2	20.6	38.4	56.1	31.8 mm	7.9	8.1	75.9	96.0	10.4	71.1	40.6	9.9	69.6
120	in.	34.0	36.3	72.5	8.1	15.1	22.1	2"	3.1	3.2	29.9	37.8	4.1	28.0	16.0	3.9	27.4
	cm.	86.4	92.2	184.2	20.6	38.4	56.1	50.8 mm	7.9	8.1	75.9	96.0	10.4	71.1	40.6	9.9	69.6
150-180	in.	34.0	46.3	72.5	8.1	15.1	22.1	2"	3.1	2.2	39.9	37.8	4.1	38.0	16.0	3.9	27.4
	cm.	86.4	117.5	184.2	20.6	38.4	56.1	50.8 mm	7.9	5.6	101.3	96.0	10.4	96.5	40.6	9.9	69.6

\*Dimensions for return connections are for the deluxe filter rack that is suitable for ducted return applications

The manufacturer works continually to improve its products. As a result, the design and specifications of each product at the time of order may be changed without notice. Purchaser's approval of this data set signifies that the equipment is acceptable under the provisions of the job specification. Statements and other information contained herein are not express warranties and do not form the basis of any bargain between the parties, but are merely the manufacturer's opinion or commendation of its products. York and Affinity are registered trademarks of Johnson Controls, Inc., and are used with permission.

Contractor: \_\_\_\_\_ P.O.: \_\_\_\_\_

Engineer: \_\_\_\_\_

Project Name: \_\_\_\_\_ Unit Tag: \_\_\_\_\_

**Affinity YDL Series**  
**Single Capacity**  
**7 - 30 Tons 60Hz**



## Dimensional Data cont.

### LEFT RETURN SHOWN

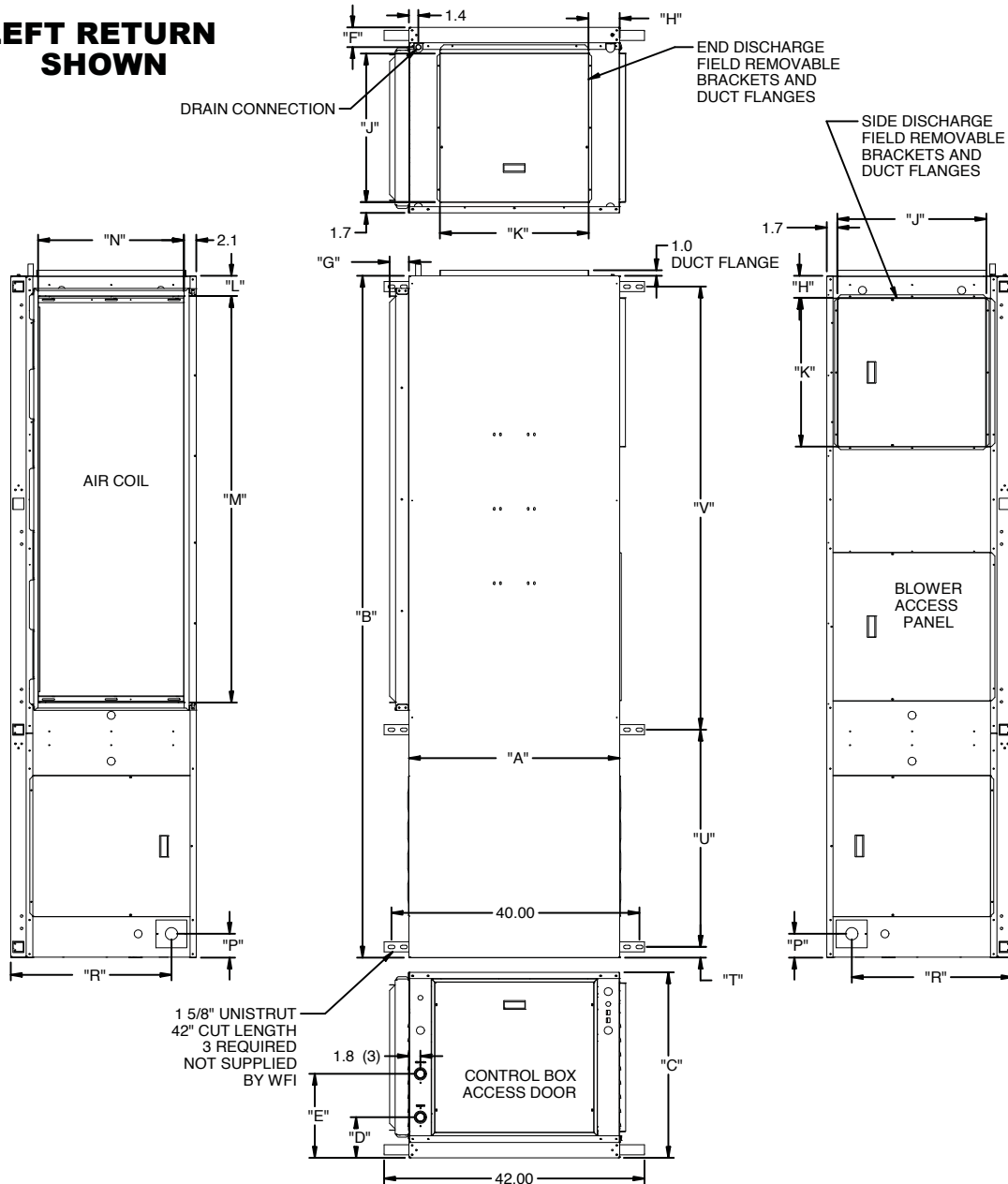

### Horizontal Dimensional Data

Horizontal Models	Overall Cabinet			Water Connections				Discharge Connection				Return Connection*			Electrical Connections		Unistrut Hanging			
	A	B	C	1	2	5	using deluxe filter rack				P	R	T	U	V					
	Width	Depth	Height	In	Out	Condensate	Loop	Filler Rack Width	H From Edge	J Supply Height	K Supply Width	L From Edge	M Return Depth	N Return Height	From Edge	Height	From Edge	Unistrut/Unistrut	Unistrut/Unistrut	
084-096	in.	34.0	89.0	29.9	8.1	15.1	3.2	1 1/4"	3.1	5.0	24.0	24.0	4.3	47.6	23.5	3.9	25.9	1.7	24.6	61.0
	cm.	86.4	226.1	75.9	20.6	38.4	8.1	31.8 mm	7.9	12.7	61.0	61.0	10.9	120.9	59.7	9.9	65.8	4.3	62.5	154.9
120	in.	34.0	89.0	29.9	8.1	15.1	3.2	2"	3.1	5.0	24.0	24.0	4.3	47.6	23.5	3.9	25.9	1.7	24.6	61.0
	cm.	86.4	226.1	75.9	20.6	38.4	8.1	50.8 mm	7.9	12.7	61.0	61.0	10.9	120.9	59.7	9.9	65.8	4.3	62.5	154.9
150-180	in.	34.0	110.0	29.9	8.1	15.1	3.2	2"	3.1	5.0	24.0	24.0	4.3	65.6	23.5	3.9	25.9	1.7	35.1	71.5
	cm.	86.4	279.4	75.9	20.6	38.4	8.1	50.8 mm	7.9	12.7	61.0	61.0	10.9	166.6	59.7	9.8	65.8	4.3	89.2	181.6

\*Dimensions for return connections are for the deluxe filter rack that is suitable for ducted return applications

The manufacturer works continually to improve its products. As a result, the design and specifications of each product at the time of order may be changed without notice. Purchaser's approval of this data set signifies that the equipment is acceptable under the provisions of the job specification. Statements and other information contained herein are not express warranties and do not form the basis of any bargain between the parties, but are merely the manufacturer's opinion or commendation of its products. York and Affinity are registered trademarks of Johnson Controls, Inc., and are used with permission.

Contractor: \_\_\_\_\_ P.O.: \_\_\_\_\_

Engineer: \_\_\_\_\_

Project Name: \_\_\_\_\_ Unit Tag: \_\_\_\_\_

Affinity YDL Series  
Single Capacity  
7 - 30 Tons 60Hz



## Dimensional Data cont.

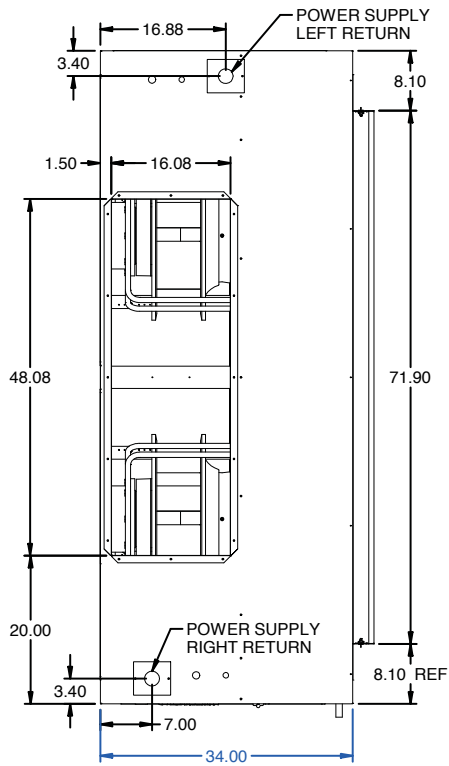

**240-360  
RIGHT RETURN  
SHOWN**

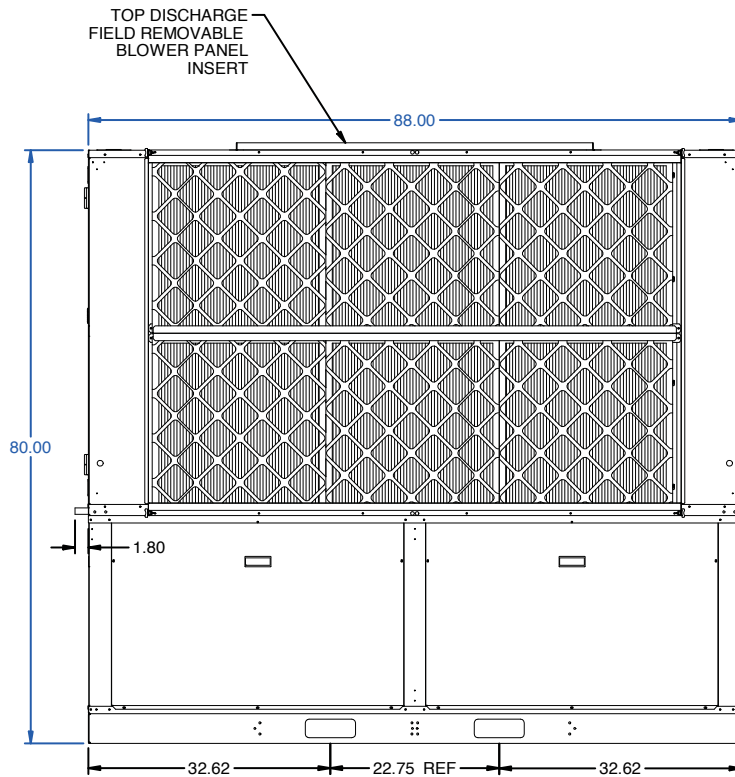
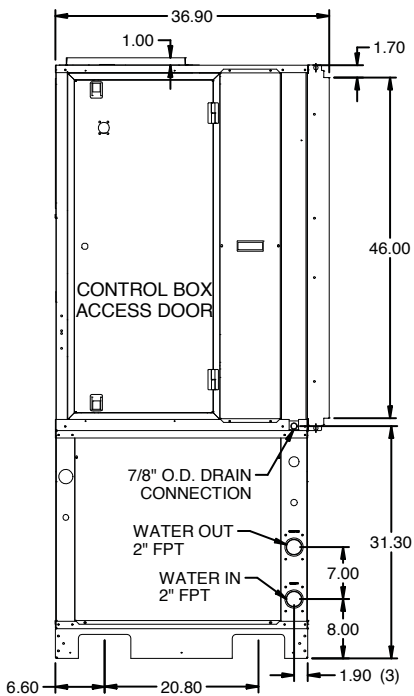
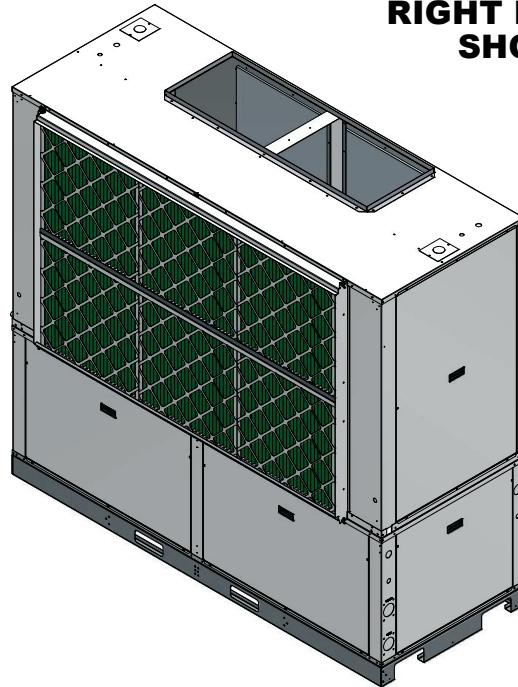

The manufacturer works continually to improve its products. As a result, the design and specifications of each product at the time of order may be changed without notice. Purchaser's approval of this data set signifies that the equipment is acceptable under the provisions of the job specification. Statements and other information contained herein are not express warranties and do not form the basis of any bargain between the parties, but are merely the manufacturer's opinion or commendation of its products. York and Affinity are registered trademarks of Johnson Controls, Inc., and are used with permission.



Contractor: \_\_\_\_\_ P.O.: \_\_\_\_\_

Engineer: \_\_\_\_\_

Project Name: \_\_\_\_\_ Unit Tag: \_\_\_\_\_

## Physical Data

Model	Dual Capacity Compressor and Fan			Two Compressors and Fan		Two Compressors and Two Fans		
	084	096	120	150	180	240	300	360
Compressor	Scroll (1 each)			Scroll (2 each)		Scroll (2 each)		
Factory Charge R410A, oz [kg] (each circuit), Vertical	130 [3.69]	132 [3.74]	190 [5.39]	112 [3.18]	128 [3.63]	196 [5.57]	224 [6.35]	230 [6.52]
Factory Charge R410A, oz [kg] (each circuit), Horizontal	126 [3.57]	130 [3.69]	176 [4.99]	112 [3.18]	126 [3.57]	N/A	N/A	N/A
<b>Blower Motor &amp; Blower</b>								
Blower Motor - Quantity	1	1	1	1	1	2	2	2
Blower Motor Type/Speeds	Backward Curve VS ECM							
Blower Motor 230V - hp [kW]	4.56 [3.4]	4.8 [3.6]	4.8 [3.6]	4.8 [3.6]	4.8 [3.6]	4.8 [3.6]	4.8 [3.6]	4.8 [3.6]
Blower Motor 460V - hp [kW]	5.5 [4.1]	7.2 [5.4]	7.2 [5.4]	7.2 [5.4]	7.2 [5.4]	7.2 [5.4]	7.2 [5.4]	7.2 [5.4]
Blower Wheel Size (Dia), in. [mm]	15.7 [400]	19.7 [500]	19.7 [500]	19.7 [500]	19.7 [500]	19.7 [500]	19.7 [500]	19.7 [500]
<b>Coax and Water Piping</b>								
Water Connections Size - FPT - in [mm]	1 1/4 [31.75]	1 1/4 [31.75]	2 [50.8]	2 [50.8]	2 [50.8]	2 [50.8]	2 [50.8]	2 [50.8]
Coax & Piping Water Volume - gal [l]	1.47 [5.56]	1.47 [5.56]	2.01 [7.61]	2.38 [9.01]	2.72 [10.29]	3.57 [13.53]	4.83 [18.29]	5.26 [19.92]
<b>Vertical Air Coil &amp; Filters</b>								
Air Coil Dimensions (H x W), in. [mm]	40 x 30 [1016 x 762]	40 x 30 [1016 x 762]	40 x 40 [1016 x 1016]	40 x 38.5 [1016 x 978]	40 x 38.5 [1016 x 978]	48 x 67.5 [1219 x 1715]	48 x 67.5 [1219 x 1715]	48 x 67.5 [1219 x 1715]
Air Coil Total Face Area, ft2 [m2]	8.34 [0.77]	8.34 [0.77]	11.11 [1.03]	10.69 [0.99]	10.69 [0.99]	22.5 [2.09]	22.5 [2.09]	22.5 [2.09]
Air Coil Tube Size, in [mm]	3/8 [9.5]	3/8 [9.5]	3/8 [9.5]	3/8 [9.5]	3/8 [9.5]	3/8 [9.5]	3/8 [9.5]	3/8 [9.5]
Air Coil Number of rows	3	3	4	4	4	3	3	3
Filter Standard - 1" [25mm] Pleated MERV 4 Throwaway, in [mm]	40 x 32 [1016 x 813]	40 x 32 [1016 x 813]	40 x 32 [1016 x 813]	42 x 40 [1067 x 1016]	42 x 40 [1067 x 1016]	6- 24 x 24 [610 x 610]	6- 24 x 24 [610 x 610]	6- 24 x 24 [610 x 610]
Filter Standard - 2" [51mm] Pleated MERV 8 Throwaway, in [mm]	40 x 32 [1016 x 813]	40 x 32 [1016 x 813]	40 x 32 [1016 x 813]	42 x 40 [1067 x 1016]	42 x 40 [1067 x 1016]	6- 24 x 24 [610 x 610]	6- 24 x 24 [610 x 610]	6- 24 x 24 [610 x 610]
Filter Standard - 2" [51mm] Pleated MERV 13 Throwaway, in [mm]	40 x 32 [1016 x 813]	40 x 32 [1016 x 813]	40 x 32 [1016 x 813]	42 x 40 [1067 x 1016]	42 x 40 [1067 x 1016]	6- 24 x 24 [610 x 610]	6- 24 x 24 [610 x 610]	6- 24 x 24 [610 x 610]
Filter Standard - 4" [102mm] Pleated MERV 13 Throwaway, in [mm]	40 x 32 [1016 x 813]	40 x 32 [1016 x 813]	40 x 32 [1016 x 813]	42 x 40 [1067 x 1016]	42 x 40 [1067 x 1016]	6- 24 x 24 [610 x 610]	6- 24 x 24 [610 x 610]	6- 24 x 24 [610 x 610]
<b>Horizontal Air Coil &amp; Filters</b>								
Air Coil Dimensions (H x W), in. [mm]	26 x 48 [660 x 1219]	26 x 48 [660 x 1219]	26 x 48 [660 x 1219]	26 x 64 [660 x 1626]	26 x 64 [660 x 1626]			
Air Coil Total Face Area, ft2 [m2]	8.67 [0.81]	8.67 [0.81]	8.67 [0.81]	11.56 [1.07]	11.56 [1.07]			
Air Coil Tube Size, in [mm]	3/8 [9.5]	3/8 [9.5]	3/8 [9.5]	3/8 [9.5]	3/8 [9.5]			
Air Coil Number of rows	3	3	4	4	4			
Filter Standard - 1" [25mm] Pleated MERV 4 Throwaway, in [mm]	2 - 25 x 25 [635 x 635]	2 - 25 x 25 [635 x 635]	2 - 25 x 25 [635 x 635]	2 - 25 x 25 [635 x 635] 1- 18 x 25 [457 x 635]	2 - 25 x 25 [635 x 635] 1- 18 x 25 [457 x 635]			
Filter Standard - 2" [51mm] Pleated MERV 13 Throwaway, in [mm]	2 - 25 x 25 [635 x 635]	2 - 25 x 25 [635 x 635]	2 - 25 x 25 [635 x 635]	2 - 25 x 25 [635 x 635] 1- 18 x 25 [457 x 635]	2 - 25 x 25 [635 x 635] 1- 18 x 25 [457 x 635]			
Filter Standard - 4" [102mm] Pleated MERV 13 Throwaway, in [mm]	2 - 25 x 25 [635 x 635]	2 - 25 x 25 [635 x 635]	2 - 25 x 25 [635 x 635]	2 - 25 x 25 [635 x 635] 1- 18 x 25 [457 x 635]	2 - 25 x 25 [635 x 635] 1- 18 x 25 [457 x 635]			

3/30/2021

The manufacturer works continually to improve its products. As a result, the design and specifications of each product at the time of order may be changed without notice. Purchaser's approval of this data set signifies that the equipment is acceptable under the provisions of the job specification. Statements and other information contained herein are not express warranties and do not form the basis of any bargain between the parties, but are merely the manufacturer's opinion or commendation of its products. York and Affinity are registered trademarks of Johnson Controls, Inc., and are used with permission.



Contractor: \_\_\_\_\_ P.O.: \_\_\_\_\_

Engineer: \_\_\_\_\_

Project Name: \_\_\_\_\_ Unit Tag: \_\_\_\_\_

## Electrical Data

Electrical Table 7-30 Ton Plenum Fan

	Model	Rated Voltage	Voltage Min/Max	Compressor (each)			Blower Motor (each) FLA	Total Unit FLA	Min Circ Amp	Max Fuse/HACR Breaker
				MCC	RLA	LRA				
Dual Capacity Compressor	084	208-230/60/3	187/253	39.5	23.3	184.0	5.3	28.6	34.4	55
		460/60/3	414/506	15.0	8.8	84.0	3.0	11.8	14.0	20
		575/60/3	518/632	13.1	8.4	60.0	2.4	10.8	12.9	20
	096	208-230/60/3	187/253	41.9	24.7	164.0	7.0	31.7	37.9	60
		460/60/3	414/506	18.7	11.0	94.0	4.0	15.0	17.8	25
		575/60/3	518/632	14.0	9.0	65.0	3.2	12.2	14.5	20
	120	208-230/60/3	187/253	50.8	30.0	240.0	7.0	37.0	44.5	70
		460/60/3	414/506	23.1	13.6	130.0	4.0	17.6	21.0	30
		575/60/3	518/632	17.3	11.1	93.7	3.2	14.3	17.1	25
Two Compressors & Plenum Fan	150	208-230/60/3	187/253	29.7	19.0	123.0	9.2	47.2	52.0	70
		460/60/3	414/506	15.2	9.7	62.0	6.8	26.2	28.6	35
		575/60/3	518/632	11.6	7.4	50.0	5.4	20.2	22.1	25
	180	208-230/60/3	187/253	39.0	25.0	164.0	9.2	59.2	65.5	90
		460/60/3	414/506	20.0	12.8	100.0	6.8	32.4	35.6	45
		575/60/3	518/632	15.0	9.6	78.0	5.4	24.6	27.0	35
Two Compressors & Two Plenum Fans	240	208-230/60/3	187/253	44.0	28.2	240.0	9.2	74.8	81.9	110
		460/60/3	414/506	23.0	14.7	130.0	6.8	43.0	46.7	60
		575/60/3	518/632	17.6	11.3	93.7	5.4	33.5	36.3	45
	300	208-230/60/3	187/253	75.0	48.1	245.0	9.2	114.6	126.6	175
		460/60/3	414/506	29.0	18.6	125.0	6.8	50.8	55.5	70
		575/60/3	518/632	23.0	14.7	100.0	5.4	40.3	44.0	55
	360	208-230/60/3	187/253	75.0	48.1	351.0	9.2	114.6	126.6	175
		460/60/3	414/506	38.6	24.7	197.0	6.8	63.0	69.2	90
		575/60/3	518/632	35.0	22.4	135.0	5.4	55.7	61.3	80

HACR circuit breaker in USA only

3/30/2021

The manufacturer works continually to improve its products. As a result, the design and specifications of each product at the time of order may be changed without notice. Purchaser's approval of this data set signifies that the equipment is acceptable under the provisions of the job specification. Statements and other information contained herein are not express warranties and do not form the basis of any bargain between the parties, but are merely the manufacturer's opinion or commendation of its products. York and Affinity are registered trademarks of Johnson Controls, Inc., and are used with permission.





Contractor: \_\_\_\_\_ P.O.: \_\_\_\_\_

Engineer: \_\_\_\_\_

Project Name: \_\_\_\_\_ Unit Tag: \_\_\_\_\_

## Blower Performance Data

### Integrated EC Backward Curved Plenum Fan Performance

#### Model 084

Fan Speed	Fan RPM	Airflow [cfm] at External Static Pressure [in. wg.]																				
		0.0	0.1	0.2	0.3	0.4	0.5	0.6	0.7	0.8	0.9	1.0	1.1	1.2	1.3	1.4	1.5	1.6	1.7	1.8	1.9	2.0
1	900	1395	1315	1215	1090	940	775	495														
2	1100	1725	1640	1570	1485	1400	1280	1150	1015	870	620											
3	1300	2055	1985	1925	1865	1800	1725	1645	1550	1435	1315	1190	1060	1055	870							
4	1400	2220	2165	2100	2045	1990	1915	1850	1770	1685	1595	1490	1375	1260	1105	955						
5	1600	2555	2505	2435	2390	2335	2285	2230	2175	2110	2045	1970	1885	1800	1705	1605	1510	1375	1265			
6	1700	2715	2660	2610	2545	2505	2460	2415	2365	2305	2250	2180	2125	2050	1970	1885	1800	1695	1600	1495	1350	1275
7	1800	2810	2785	2705	2655	2600	2540	2495	2415	2355	2305	2265	2210	2175	2120	2085	2015	1965	1905	1855	1795	1705
8	1900	2970	2910	2865	2805	2775	2715	2665	2615	2575	2520	2460	2405	2360	2300	2245	2185	2130	2075	2020	1965	1895
9	2000	3145	3105	3075	3015	2945	2900	2855	2805	2745	2695	2655	2585	2520	2475	2430	2380	2305	2245	2175	2100	2030
10	2100	3320	3300	3285	3225	3115	3085	3045	2995	2915	2870	2850	2765	2680	2650	2615	2575	2480	2415	2330	2235	2165
11	2200	3460	3415	3380	3315	3245	3240	3195	3120	3085	3050	3020	2985	2915	2865	2805	2780	2715	2635	2575	2520	2475
12	2300	3625	3575	3505	3460	3425	3395	3345	3245	3255	3230	3190	3165	3120	3075	3025	2990	2950	2855	2820	2785	2715

Fan selection is accomplished through the Aurora Controls and allows four online selections of continuous fan (G), L = stage 1 (Y1), H = stage 2 (Y2), and Aux = electric heat. 3/30/21  
 Continuous Fan (G) can be set at any airflow. Factory setting is 1.  
 L = Stage 1 (Y1) factory setting is 3.  
 H = Stage 2 (Y2) factory setting is 8.  
 Electric Heat Operation (AUX) = Stage 3 factory setting is 10.  
 Electric heat Airflow (AUX) airflow setting should be configured for the minimum airflow needed to support the heater. Please consult heater manual.

#### Model 096

Fan Speed	Fan RPM	Airflow [cfm] at External Static Pressure [in. wg.]																				
		0.0	0.1	0.2	0.3	0.4	0.5	0.6	0.7	0.8	0.9	1.0	1.1	1.2	1.3	1.4	1.5	1.6	1.7	1.8	1.9	2.0
1	600	1530	1430	1205	915	525	420															
2	700	1835	1710	1530	1410	1165	870	495														
3	800	2145	2030	1895	1740	1565	1385	1125	825	570												
4	900	2530	2415	2290	2145	1985	1825	1665	1440	1200	920											
5	1000	2815	2720	2620	2505	2365	2235	2085	1915	1755	1555	1325	1115	780								
6	1100	3135	3045	2955	2830	2735	2615	2470	2335	2195	2045	1915	1745	1490	1315							
7	1200	3440	3360	3275	3195	3095	2985	2895	2750	2645	2505	2375	2225	2085	1915	1730	1525	1235				
8	1300	3745	3685	3595	3505	3415	3335	3235	3120	3035	2910	2795	2680	2555	2420	2305	2150	1955	1770	1575		
9	1400	4045	3995	3905	3830	3775	3680	3580	3500	3415	3310	3195	3165	2985	2875	2750	2630	2505	2375	2255	2070	1905
10	1500	4370	4285	4220	4150	4085	4010	3920	3850	3775	3680	3595	3505	3400	3305	3195	3075	2940	2830	2750	2645	2525
11	1600	4875	4575	4545	4480	4400	4335	4250	4200	4115	4065	3975	3865	3795	3695	3600	3500	3395	3290	3180	3085	2970
12	1700	5200	5120	5060	5000	4935	4665	4575	4510	4415	4345	4280	4210	4130	4040	3960	3875	3795	3680	3605	3515	3425

Fan selection is accomplished through the Aurora Controls and allows four online selections of continuous fan (G), L = stage 1 (Y1), H = stage 2 (Y2), and Aux = electric heat. 3/30/21  
 Continuous Fan (G) can be set at any airflow. Factory setting is 1.  
 L = Stage 1 (Y1) factory setting is 4.  
 H = Stage 2 (Y2) factory setting is 7.  
 Electric Heat Operation (AUX) = Stage 3 factory setting is 10.  
 Electric heat Airflow (AUX) airflow setting should be configured for the minimum airflow needed to support the heater. Please consult heater manual.

#### Model 120

Fan Speed	Fan RPM	Airflow [cfm] at External Static Pressure [in. wg.]																				
		0.0	0.1	0.2	0.3	0.4	0.5	0.6	0.7	0.8	0.9	1.0	1.1	1.2	1.3	1.4	1.5	1.6	1.7	1.8	1.9	2.0
1	700	1835	1710	1530	1410	1165	870	495														
2	800	2145	2030	1895	1740	1565	1385	1125	825	570												
3	900	2530	2415	2290	2145	1985	1825	1665	1440	1200	920											
4	1000	2815	2720	2620	2505	2365	2235	2085	1915	1755	1555	1325	1115	780								
5	1100	3135	3045	2955	2830	2735	2615	2470	2335	2195	2045	1915	1745	1490	1315							
6	1200	3440	3360	3275	3195	3095	2985	2895	2750	2645	2505	2375	2225	2085	1915	1730	1525	1235				
7	1300	3745	3685	3595	3505	3415	3335	3235	3120	3035	2910	2795	2680	2555	2420	2305	2150	1955	1770	1575		
8	1400	4045	3995	3905	3830	3775	3680	3580	3500	3415	3310	3195	3165	2985	2875	2750	2630	2505	2375	2255	2070	1905
9	1500	4370	4285	4220	4150	4085	4010	3920	3850	3775	3680	3595	3505	3400	3305	3195	3075	2940	2830	2750	2645	2525
10	1600	4875	4775	4545	4480	4400	4335	4250	4200	4115	4065	3975	3865	3795	3695	3600	3500	3395	3290	3180	3085	2970
11	1700	5200	5120	5060	5000	4935	4665	4575	4510	4415	4345	4280	4210	4130	4040	3960	3875	3795	3680	3605	3515	3425
12	1800	5525	5405	5310	5200	5105	4995	4860	4755	4695	4625	4555	4480	4410	4350	4295	4225	4160	4070	3985	3900	3820

Fan selection is accomplished through the Aurora Controls and allows four online selections of continuous fan (G), L = stage 1 (Y1), H = stage 2 (Y2), and Aux = electric heat. 3/30/21  
 Continuous Fan (G) can be set at any airflow. Factory setting is 1.  
 L = Stage 1 (Y1) factory setting is 4.  
 H = Stage 2 (Y2) factory setting is 8.  
 Electric Heat Operation (AUX) = Stage 3 factory setting is 10.  
 Electric heat Airflow (AUX) airflow setting should be configured for the minimum airflow needed to support the heater. Please consult heater manual.

The manufacturer works continually to improve its products. As a result, the design and specifications of each product at the time of order may be changed without notice. Purchaser's approval of this data set signifies that the equipment is acceptable under the provisions of the job specification. Statements and other information contained herein are not express warranties and do not form the basis of any bargain between the parties, but are merely the manufacturer's opinion or commendation of its products. York and Affinity are registered trademarks of Johnson Controls, Inc., and are used with permission.



Contractor: \_\_\_\_\_ P.O.: \_\_\_\_\_

Engineer: \_\_\_\_\_

Project Name: \_\_\_\_\_ Unit Tag: \_\_\_\_\_

## Blower Performance Data cont.

### Model 150

Fan Speed	Fan RPM	Airflow [cfm] at External Static Pressure [in. wg.]																				
		0.0	0.1	0.2	0.3	0.4	0.5	0.6	0.7	0.8	0.9	1.0	1.1	1.2	1.3	1.4	1.5	1.6	1.7	1.8	1.9	2.0
1	900	2780	2665	2545	2400	2230	2055	1880	1650													
2	1000	3095	2990	2885	2780	2675	2515	2345	2175	2005	1830	1590										
3	1100	3415	3325	3230	3135	3045	2905	2795	2680	2570	2460	2155	1985									
4	1200	3750	3660	3565	3470	3370	3275	3165	3055	2935	2805	2680	2530	2375	2195	1995						
5	1300	4055	3980	3905	3815	3725	3635	3540	3445	3335	3215	3100	2975	2845	2700	2545	2385	2190	1995	1802		
6	1400	4375	4305	4230	4155	4070	3985	3900	3815	3720	3620	3520	3395	3275	3160	3040	2925	2765	2605	2445	2285	2120
7	1500	4810	4700	4585	4495	4420	4345	4255	4170	4090	4015	3945	3840	3735	3635	3530	3425	3295	3165	3035	2895	2765
8	1600	5245	5095	4940	4835	4770	4685	4605	4525	4450	4385	4320	4225	4135	4035	3945	3855	3745	3640	3530	3415	3300
9	1700	5680	5490	5295	5175	5120	5025	4955	4880	4810	4755	4680	4600	4520	4435	4345	4255	4175	4090	4000	3895	3795
10	1800	6115	5885	5650	5515	5470	5365	5305	5235	5170	5125	5040	4975	4905	4835	4730	4650	4570	4490	4405	4315	4220
11	1900	6550	6280	6005	5855	5820	5705	5655	5590	5530	5495	5400	5350	5290	5235	5115	5045	4965	4890	4810	4735	4645
12	2000	6985	6675	6360	6195	6155	6045	6005	5945	5890	5865	5760	5725	5675	5635	5500	5440	5360	5290	5215	5155	5070

Fan selection is accomplished through the Aurora Controls and allows four online selections of continuous fan (G), L = stage 1 (Y1), 3/30/21  
H = stage 2 (Y2), and Aux = electric heat.

Continuous Fan (G) can be set at any airflow. Factory setting is 1.

L = Stage 1 (Y1) factory setting is 2.

H = Stage 2 (Y2) factory setting is 9.

Electric Heat Operation (AUX) = Stage 3 factory setting is 10.

Elect heat Airflow (AUX) airflow setting should be configured for the minimum airflow needed to support the heater. Please consult heater manual.

### Model 180

Fan Speed	Fan RPM	Airflow [cfm] at External Static Pressure [in. wg.]																				
		0.0	0.1	0.2	0.3	0.4	0.5	0.6	0.7	0.8	0.9	1.0	1.1	1.2	1.3	1.4	1.5	1.6	1.7	1.8	1.9	2.0
1	900	2454	2341	2214	2075	1923	1758	1580	1389													
2	1000	2978	2881	2773	2669	2531	2407	2253	2087	1908	1679	1432										
3	1100	3288	3202	3121	3012	2908	2800	2679	2521	2385	2230	2050	1839	1617	1281							
4	1200	3587	3507	3433	3343	3249	3145	3037	2926	2791	2659	2490	2364	2218	2037	1825	1568					
5	1300	3901	3835	3761	3664	3594	3507	3418	3319	3202	3104	2969	2864	2735	2581	2417	2230	2098	1928			
6	1400	4244	4182	4120	4057	3974	3896	3809	3727	3629	3536	3455	3326	3224	3110	2983	2833	2718	2581	2440	2293	
7	1500	4812	4738	4664	4587	4504	4438	4372	4291	4226	4134	4046	3962	3870	3780	3707	3579	3501	3404	3305	3204	3101
8	1700	5329	5262	5195	5139	5082	5020	4958	4895	4831	4752	4673	4601	4529	4455	4380	4294	4222	4145	4068	3990	3911
9	1800	5666	5607	5548	5481	5414	5353	5291	5221	5151	5086	5020	4953	4886	4811	4735	4671	4596	4523	4450	4375	4300
10	1900	6018	5957	5895	5833	5770	5712	5654	5589	5524	5463	5402	5340	5278	5208	5138	5047	4976	4907	4837	4766	4695
11	2000	6350	6287	6224	6165	6105	6045	5985	5923	5861	5799	5736	5672	5607	5541	5475	5414	5347	5281	5214	5148	5080
12	2160	6862	6805	6748	6698	6647	6588	6529	6477	6425	6364	6303	6249	6194	6131	6068	5987	5920	5854	5787	5721	5653

Fan selection is accomplished through the Aurora Controls and allows four online selections of continuous fan (G), L = stage 1 (Y1), 3/30/21  
H = stage 2 (Y2), and Aux = electric heat.

Continuous Fan (G) can be set at any airflow. Factory setting is 1.

L = Stage 1 (Y1) factory setting is 3.

H = Stage 2 (Y2) factory setting is 9.

Electric Heat Operation (AUX) = Stage 3 factory setting is 10.

Elect heat Airflow (AUX) airflow setting should be configured for the minimum airflow needed to support the heater. Please consult heater manual.

The manufacturer works continually to improve its products. As a result, the design and specifications of each product at the time of order may be changed without notice. Purchaser's approval of this data set signifies that the equipment is acceptable under the provisions of the job specification. Statements and other information contained herein are not express warranties and do not form the basis of any bargain between the parties, but are merely the manufacturer's opinion or commendation of its products. York and Affinity are registered trademarks of Johnson Controls, Inc., and are used with permission.

Contractor: \_\_\_\_\_ P.O.: \_\_\_\_\_

Engineer: \_\_\_\_\_

Project Name: \_\_\_\_\_ Unit Tag: \_\_\_\_\_



## Blower Performance Data cont.

### Model 240

Fan Speed	Fan RPM	Airflow [cfm] at External Static Pressure [in. wg.]																				
		0.0	0.1	0.2	0.3	0.4	0.5	0.6	0.7	0.8	0.9	1.0	1.1	1.2	1.3	1.4	1.5	1.6	1.7	1.8	1.9	2.0
1	900	5755	5525	5290	5005	4725	5045	4075	3645	3205	2635											
2	1000	6610	6345	6080	5815	5550	5285	5020	4725	4425	4035	3640	3155									
3	1100	7465	7165	6870	6625	6375	5525	5965	5805	5400	5105	4810	4440	4075	3495	2915						
4	1200	7815	7650	7485	7295	7105	6915	6725	6540	6355	6095	5835	5540	5245	4755	4265	3995	3730	3075			
5	1300	8505	8355	8205	8040	7875	7705	7530	7335	7145	6925	6710	6505	6300	5975	5655	5165	4681	4568	4455	3870	3285
6	1400	9195	9020	8850	8705	8565	8395	8225	8060	7895	7710	7525	7355	7190	6975	6760	6380	6000	5500	5000	4600	4200
7	1500	9885	9785	9605	9470	9335	9180	9025	8895	8770	8575	8385	8215	8045	7850	7655	7415	7175	6740	6305	5870	5435
8	1600	10575	10545	10360	10235	10105	9930	9760	9605	9450	9325	9205	9045	8890	8725	8565	8385	8205	8005	7810	7565	7325
9	1700	11265	11105	11055	11000	10875	10680	10570	10435	10300	10160	10025	9880	9740	9590	9445	9275	9110	8880	8655	8275	7900
10	1800	11955	11860	11750	11695	11645	11430	11380	11265	11150	10995	10715	10595	10480	10340	10205	10065	9930	9770	9610	9305	9005
11	1900	12645	12615	12445	12390	12285	12180	12105	12085	12000	11830	11405	11310	11220	11090	10975	10845	10715	10565	10420	10280	10145
12	2000	13335	13230	13140	13085	12925	12885	12830	12755	12705	12665	12395	12025	11960	11840	11745	11625	11500	11360	11225	11085	10945

Fan selection is accomplished through the Aurora Controls and allows four online selections of continuous fan (G), L = stage 1 (Y1), H = stage 2 (Y2), and Aux = electric heat. 3/30/21

Continuous Fan (G) can be set at any airflow. Factory setting is 1.

L = Stage 1 (Y1) factory setting is 3.

H = Stage 2 (Y2) factory setting is 6.

Electric Heat Operation (AUX) = Stage 3 factory setting is 8.

Elect heat Airflow (AUX) airflow setting should be configured for the minimum airflow needed to support the heater. Please consult heater manual.

### Model 300

Fan Speed	Fan RPM	Airflow [cfm] at External Static Pressure [in. wg.]																				
		0.0	0.1	0.2	0.3	0.4	0.5	0.6	0.7	0.8	0.9	1.0	1.1	1.2	1.3	1.4	1.5	1.6	1.7	1.8	1.9	2.0
1	900	5755	5525	5290	5005	4725	5045	4075	3645	3205	2635											
2	1000	6610	6345	6080	5815	5550	5285	5020	4725	4425	4035	3640	3155									
3	1100	7465	7165	6870	6625	6375	5525	5965	5805	5400	5105	4810	4440	4075	3495	2915						
4	1200	7815	7650	7485	7295	7105	6915	6725	6540	6355	6095	5835	5540	5245	4755	4265	3995	3730	3075			
5	1300	8505	8355	8205	8040	7875	7705	7530	7335	7145	6925	6710	6505	6300	5975	5655	5165	4681	4568	4455	3870	3285
6	1400	9195	9020	8850	8705	8565	8395	8225	8060	7895	7710	7525	7355	7190	6975	6760	6380	6000	5500	5000	4600	4200
7	1500	9885	9785	9605	9470	9335	9180	9025	8895	8770	8575	8385	8215	8045	7850	7655	7415	7175	6740	6305	5870	5435
8	1600	10575	10545	10360	10235	10105	9930	9760	9605	9450	9325	9205	9045	8890	8725	8565	8385	8205	8005	7810	7565	7325
9	1700	11265	11105	11055	11000	10875	10680	10570	10435	10300	10160	10025	9880	9740	9590	9445	9275	9110	8880	8655	8275	7900
10	1800	11955	11860	11750	11695	11645	11430	11380	11265	11150	10995	10715	10595	10480	10340	10205	10065	9930	9770	9610	9305	9005
11	1900	12645	12615	12445	12390	12285	12180	12105	12085	12000	11830	11405	11310	11220	11090	10975	10845	10715	10565	10420	10280	10145
12	2000	13335	13230	13140	13085	12925	12885	12830	12755	12705	12665	12395	12025	11960	11840	11745	11625	11500	11360	11225	11085	10945

Fan selection is accomplished through the Aurora Controls and allows four online selections of continuous fan (G), L = stage 1 (Y1), H = stage 2 (Y2), and Aux = electric heat. 3/30/21

Continuous Fan (G) can be set at any airflow. Factory setting is 1.

L = Stage 1 (Y1) factory setting is 3.

H = Stage 2 (Y2) factory setting is 8.

Electric Heat Operation (AUX) = Stage 3 factory setting is 9.

Elect heat Airflow (AUX) airflow setting should be configured for the minimum airflow needed to support the heater. Please consult heater manual.

### Model 360

Fan Speed	Fan RPM	Airflow [cfm] at External Static Pressure [in. wg.]																				
		0.0	0.1	0.2	0.3	0.4	0.5	0.6	0.7	0.8	0.9	1.0	1.1	1.2	1.3	1.4	1.5	1.6	1.7	1.8	1.9	2.0
1	900	5755	5525	5290	5005	4725	5045	4075	3645	3205	2635											
2	1000	6610	6345	6080	5815	5550	5285	5020	4725	4425	4035	3640	3155									
3	1100	7465	7165	6870	6625	6375	5525	5965	5805	5400	5105	4810	4440	4075	3495	2915						
4	1200	7815	7650	7485	7295	7105	6915	6725	6540	6355	6095	5835	5540	5245	4755	4265	3995	3730	3075			
5	1300	8505	8355	8205	8040	7875	7705	7530	7335	7145	6925	6710	6505	6300	5975	5655	5165	4681	4568	4455	3870	3285
6	1400	9195	9020	8850	8705	8565	8395	8225	8060	7895	7710	7525	7355	7190	6975	6760	6380	6000	5500	5000	4600	4200
7	1500	9885	9785	9605	9470	9335	9180	9025	8895	8770	8575	8385	8215	8045	7850	7655	7415	7175	6740	6305	5870	5435
8	1600	10575	10545	10360	10235	10105	9930	9760	9605	9450	9325	9205	9045	8890	8725	8565	8385	8205	8005	7810	7565	7325
9	1700	11265	11105	11055	11000	10875	10680	10570	10435	10300	10160	10025	9880	9740	9590	9445	9275	9110	8880	8655	8275	7900
10	1800	11955	11860	11750	11695	11645	11430	11380	11265	11150	10995	10715	10595	10480	10340	10205	10065	9930	9770	9610	9305	9005
11	1900	12645	12615	12445	12390	12285	12180	12105	12085	12000	11830	11405	11310	11220	11090	10975	10845	10715	10565	10420	10280	10145
12	2000	13335	13230	13140	13085	12925	12885	12830	12755	12705	12665	12395	12025	11960	11840	11745	11625	11500	11360	11225	11085	10945

Fan selection is accomplished through the Aurora Controls and allows four online selections of continuous fan (G), L = stage 1 (Y1), H = stage 2 (Y2), and Aux = electric heat. 3/30/21

Continuous Fan (G) can be set at any airflow. Factory setting is 1.

L = Stage 1 (Y1) factory setting is 4.

H = Stage 2 (Y2) factory setting is 9.

Electric Heat Operation (AUX) = Stage 3 factory setting is 10.

Elect heat Airflow (AUX) airflow setting should be configured for the minimum airflow needed to support the heater. Please consult heater manual.

The manufacturer works continually to improve its products. As a result, the design and specifications of each product at the time of order may be changed without notice. Purchaser's approval of this data set signifies that the equipment is acceptable under the provisions of the job specification. Statements and other information contained herein are not express warranties and do not form the basis of any bargain between the parties, but are merely the manufacturer's opinion or commendation of its products. York and Affinity are registered trademarks of Johnson Controls, Inc., and are used with permission.

Contractor: \_\_\_\_\_ P.O.: \_\_\_\_\_

Engineer: \_\_\_\_\_

Project Name: \_\_\_\_\_ Unit Tag: \_\_\_\_\_



## Blower Performance Data cont.

### Setting Blower Speed - Variable Speed ECM

The ABC board's Yellow Config LED will flash the current ECM blower speed selections for G, low, and high continuously with a short pause in between. The speeds can also be confirmed with the AID Tool under the Setup/ECM Setup screen. The Aux will not be flashed but can be viewed in the AID Tool. The ECM blower motor speeds can be field adjusted with or without using an AID Tool.

#### Variable speed ECM Setup without an AID Tool

The blower speeds for G only, Low (Y1), and High (Y2/Aux) can be adjusted directly at the Aurora ABC board which utilizes the push button (SW1) on the ABC board. This procedure is outlined in the ECM Configuration Mode portion of the Aurora 'Base' Control System section. The Aux cannot be set manually without an AID Tool.

#### Variable speed ECM Setup with an AID Tool

A much easier method utilizes the AID Tool to change the airflow using the procedure below. First navigate to the Setup screen and then select ECM Setup. This screen displays the current ECM settings. It allows the technician

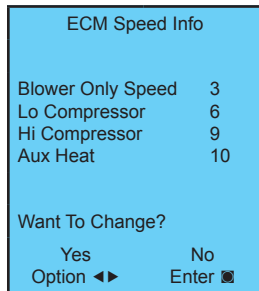

to enter the setup screens to change the ECM settings. Change the highlighted item using the ◀ and ▶ buttons and then press the ■ button to select the item.

Selecting YES will enter ECM speed setup, while selecting NO will return to the previous screen.

**ECM Speed Setup** - These screens allow the technician to select the G, low, high, and auxiliary heat blower speed for the ECM blower motor. Change the highlighted item using the ▲ and ▼ buttons. Press the ■ button to select the speed.

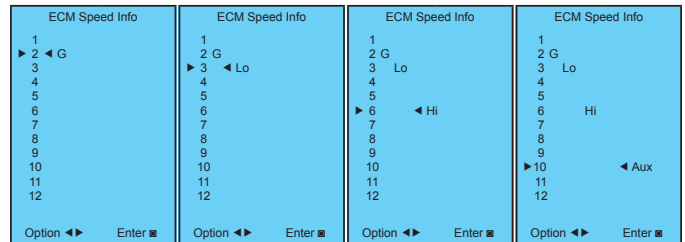

After the auxiliary heat speed setting is selected the AID Tool will automatically transfer back to the ECM Setup screen.

**Cooling Airflow Setup** - These screens allow the technician to select -15%, -10%, -5%, None or +5% change from the heating airflow. Change the adjustment percentage using the ▲ and ▼ buttons. Press the ■ button to save the change.

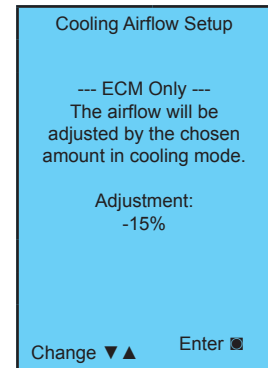
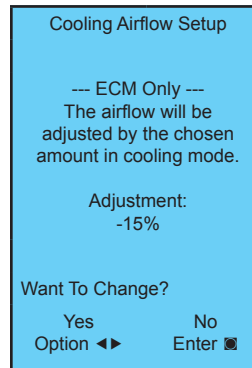



Contractor: \_\_\_\_\_ P.O.: \_\_\_\_\_

Engineer: \_\_\_\_\_

Project Name: \_\_\_\_\_ Unit Tag: \_\_\_\_\_

## Operating Limits

Operating Limits	Cooling		Heating	
	(°F)	(°C)	(°F)	(°C)
<b>Air Limits</b>				
Min. Ambient Air	45	7.2	45	7.2
Rated Ambient Air	80	26.7	70	21.1
Max. Ambient Air	100	37.8	85	29.4
Min. Entering Air	50	10.0	40	4.4
Rated Entering Air db/wb	80.6/66.2	27/19	68	20.0
Max. Entering Air db/wb	110/83	43/28.3	80	26.7
<b>Water Limits</b>				
Min. Entering Water	30	-1.1	20	-6.7
Normal Entering Water	50-110	10-43.3	30-70	-1.1
Max. Entering Water	120	48.9	90	32.2

**NOTE:** Minimum/maximum limits are only for start-up conditions, and are meant for bringing the space up to occupancy temperature. Units are not designed to operate at the minimum/maximum conditions on a regular basis. The operating limits are dependant upon three primary factors: 1) water temperature, 2) return air temperature, and 3) ambient temperature. When any of the factors are at the minimum or maximum levels, the other two factors must be at the normal level for proper and reliable unit operation.

## Definitions

### ABBREVIATIONS AND DEFINITIONS:

cfm = airflow, cubic feet/minute  
 EWT = entering water temperature, Fahrenheit  
 gpm = water flow in gallons/minute  
 WPD = water pressure drop, psi and feet of water  
 EAT = entering air temperature, Fahrenheit  
 (dry bulb/wet bulb)  
 HC = air heating capacity, MBtu/h  
 TC = total cooling capacity, MBtu/h  
 SC = sensible cooling capacity, MBtu/h  
 kW = total power unit input, kilowatts  
 HR = total heat of rejection, MBtu/h

HE = total heat of extraction, MBtu/h  
 HWC = hot water generator capacity, MBtu/h  
 EER = Energy Efficient Ratio  
 = BTU output/Watt input  
 COP = Coefficient of Performance  
 = Btu output/Btu input  
 LWT = leaving water temperature, °F  
 LAT = leaving air temperature, °F  
 TH = total heating capacity, MBtu/h  
 LC = latent cooling capacity, MBtu/h  
 S/T = sensible to total cooling ratio



Contractor: \_\_\_\_\_ P.O.: \_\_\_\_\_

Engineer: \_\_\_\_\_

Project Name: \_\_\_\_\_ Unit Tag: \_\_\_\_\_

## Correction Factor Tables

Operating Limits	Cooling		Heating	
	(°F)	(°C)	(°F)	(°C)
<b>Air Limits</b>				
Min. Ambient Air	45	7.2	45	7.2
Rated Ambient Air	80	26.7	70	21.1
Max. Ambient Air	100	37.8	85	29.4
Min. Entering Air	50	10.0	40	4.4
Rated Entering Air db/wb	80.6/66.2	27/19	68	20.0
Max. Entering Air db/wb	110/83	43/28.3	80	26.7
<b>Water Limits</b>				
Min. Entering Water	30	-1.1	20	-6.7
Normal Entering Water	50-110	10-43.3	30-70	-1.1
Max. Entering Water	120	48.9	90	32.2

**NOTE:** Minimum/maximum limits are only for start-up conditions, and are meant for bringing the space up to occupancy temperature. Units are not designed to operate at the minimum/maximum conditions on a regular basis. The operating limits are dependent upon three primary factors: 1) water temperature, 2) return air temperature, and 3) ambient temperature. When any of the factors are at the minimum or maximum levels, the other two factors must be at the normal level for proper and reliable unit operation.

### Cooling Capacity Corrections

Entering Air WB °F	Total Clg Cap	Sensible Cooling Capacity Multipliers - Entering DB °F										Power Input	Heat of Rejection
		60	65	70	75	80	80.6	85	90	95	100		
55	0.898	0.723	0.866	1.048	1.185	*	*	*	*	*	*	0.985	0.913
60	0.912		0.632	0.880	1.078	1.244	1.260	*	*	*	*	0.994	0.927
65	0.967			0.694	0.881	1.079	1.085	1.270	*	*	*	0.997	0.972
66.2	0.983			0.655	0.842	1.040	1.060	1.232	*	*	*	0.999	0.986
<b>67</b>	<b>1.000</b>			0.616	0.806	<b>1.000</b>	1.023	1.193	1.330	*	*	<b>1.000</b>	<b>1.000</b>
70	1.053				0.693	0.879	0.900	1.075	1.250	1.404	*	1.003	1.044
75	1.168					0.687	0.715	0.875	1.040	1.261	1.476	1.007	1.141

**NOTE:** \* Sensible capacity equals total capacity at conditions shown.

11/10/09

### Heating Corrections

Ent Air DB °F	Htg Cap	Power	Heat of Ext
45	1.062	0.739	1.158
50	1.050	0.790	1.130
55	1.037	0.842	1.096
60	1.025	0.893	1.064
65	1.012	0.945	1.030
68	1.005	0.976	1.012
<b>70</b>	<b>1.000</b>	<b>1.000</b>	<b>1.000</b>
75	0.987	1.048	0.970
80	0.975	1.099	0.930

11/10/09



Contractor: \_\_\_\_\_ P.O.: \_\_\_\_\_

Engineer: \_\_\_\_\_

Project Name: \_\_\_\_\_ Unit Tag: \_\_\_\_\_

## Correction Factor Tables cont.

### Air Flow Corrections (Part Load)

Airflow		Cooling				Heating		
CFM Per Ton of Clg	% of Nominal	Total Cap	Sens Cap	Power	Heat of Rej	Htg Cap	Power	Heat of Ext
240	60	0.922	0.778	0.956	0.924	0.943	1.239	0.879
275	69	0.944	0.830	0.962	0.944	0.958	1.161	0.914
300	75	0.957	0.866	0.968	0.958	0.968	1.115	0.937
325	81	0.970	0.900	0.974	0.970	0.977	1.075	0.956
350	88	0.982	0.933	0.981	0.980	0.985	1.042	0.972
375	94	0.991	0.968	0.991	0.991	0.993	1.018	0.988
<b>400</b>	<b>100</b>	<b>1.000</b>	<b>1.000</b>	<b>1.000</b>	<b>1.000</b>	<b>1.000</b>	<b>1.000</b>	<b>1.000</b>
425	106	1.007	1.033	1.011	1.008	1.007	0.990	1.010
450	113	1.013	1.065	1.023	1.015	1.012	0.987	1.018
475	119	1.017	1.099	1.037	1.022	1.018	0.984	1.025
500	125	1.020	1.132	1.052	1.027	1.022	0.982	1.031
520	130	1.022	1.159	1.064	1.030	1.025	0.979	1.034

1/4/18

### Air Flow Corrections (Full Load)

Airflow		Cooling				Heating		
CFM Per Ton of Clg	% of Nominal	Total Cap	Sens Cap	Power	Heat of Rej	Htg Cap	Power	Heat of Ext
240	60	0.922	0.786	0.910	0.920	0.943	1.150	0.893
275	69	0.944	0.827	0.924	0.940	0.958	1.105	0.922
300	75	0.959	0.860	0.937	0.955	0.968	1.078	0.942
325	81	0.971	0.894	0.950	0.967	0.977	1.053	0.959
350	88	0.982	0.929	0.964	0.978	0.985	1.031	0.973
375	94	0.992	0.965	0.982	0.990	0.993	1.014	0.988
<b>400</b>	<b>100</b>	<b>1.000</b>	<b>1.000</b>	<b>1.000</b>	<b>1.000</b>	<b>1.000</b>	<b>1.000</b>	<b>1.000</b>
425	106	1.007	1.034	1.020	1.010	1.007	0.990	1.011
450	113	1.012	1.065	1.042	1.018	1.013	0.983	1.020
475	119	1.017	1.093	1.066	1.026	1.018	0.980	1.028
500	125	1.019	1.117	1.092	1.033	1.023	0.978	1.034
520	130	1.020	1.132	1.113	1.038	1.026	0.975	1.038

1/4/18

## Pressure Drop

Model	GPM	Pressure Drop (psi)					
		30°F	50°F	70°F	90°F	110°F	
Dual Capacity Compressor	084	10.0	1.7	1.5	1.3	1.0	0.8
		16.0	3.5	3.3	3.1	2.9	2.7
		22.0	7.1	6.0	5.33	4.9	4.7
	096	12.0	1.4	1.2	1.0	0.8	0.6
		18.0	2.8	2.6	2.4	2.2	2.0
		24.0	4.9	4.6	4.4	4.2	4.0
	120	16.0	0.8	0.7	0.7	0.6	0.5
		22.0	1.5	1.3	1.2	1.2	1.1
		30.0	3.0	2.8	2.6	2.4	2.2
Two Compressor	150	24.0	3.2	3.0	2.8	2.6	2.4
		30.0	5.1	4.9	4.7	4.5	4.3
		36.0	6.9	6.7	6.5	6.3	6.1
	180	22.0	1.8	1.6	1.4	1.2	1.0
		34.0	3.0	2.8	2.6	2.4	2.2
		45.0	4.2	4.0	3.6	3.3	3.1
	240	35.0	1.8	1.6	1.5	1.4	1.2
		50.0	3.0	2.8	2.6	2.4	2.2
		60.0	6.0	5.8	5.6	5.3	5.1
	300	35.0	2.8	2.6	2.4	2.2	2.0
		50.0	4.2	4.0	3.8	3.6	3.4
		75.0	7.6	7.3	7.0	6.4	6.0
	360	50.0	3.4	3.2	3.0	2.8	2.6
		70.0	6.1	5.9	5.7	5.5	5.3
		90.0	8.7	8.5	8.3	8.1	7.9

3/30/21

The manufacturer works continually to improve its products. As a result, the design and specifications of each product at the time of order may be changed without notice. Purchaser's approval of this data set signifies that the equipment is acceptable under the provisions of the job specification. Statements and other information contained herein are not express warranties and do not form the basis of any bargain between the parties, but are merely the manufacturer's opinion or commendation of its products. York and Affinity are registered trademarks of Johnson Controls, Inc., and are used with permission.



Contractor: \_\_\_\_\_ P.O.: \_\_\_\_\_

Engineer: \_\_\_\_\_

Project Name: \_\_\_\_\_ Unit Tag: \_\_\_\_\_

## Antifreeze Corrections

### Antifreeze Corrections

Catalog performance can be corrected for antifreeze use. Please use the following table and note the example given.

Antifreeze Type	Antifreeze % by wt	Cooling Capacity	Heating Capacity	Pressure Drop
EWT - degF [DegC]		90 [32.2]	30 [-1.1]	30 [-1.1]
Water	0	1.000	1.000	1.000
Ethylene Glycol	10	0.991	0.973	1.075
	20	0.979	0.943	1.163
	30	0.965	0.917	1.225
	40	0.955	0.890	1.324
	50	0.943	0.865	1.419
Propylene Glycol	10	0.981	0.958	1.130
	20	0.969	0.913	1.270
	30	0.950	0.854	1.433
	40	0.937	0.813	1.614
	50	0.922	0.770	1.816
Ethanol	10	0.991	0.927	1.242
	20	0.972	0.887	1.343
	30	0.947	0.856	1.383
	40	0.930	0.815	1.523
	50	0.911	0.779	1.639
Methanol	10	0.986	0.957	1.127
	20	0.970	0.924	1.197
	30	0.951	0.895	1.235
	40	0.936	0.863	1.323
	50	0.920	0.833	1.399

**Warning:** Gray area represents antifreeze concentrations greater than 35% by weight and should be avoided due to the extreme performance penalty they represent.

### Antifreeze Correction Example

Antifreeze solution is Propylene Glycol 20% by weight. Determine the corrected full load heating and cooling performance at 30°F and 90°F respectively as well as pressure drop at 30°F for a \*120 model.

The corrected cooling capacity at 90°F would be: 117,200 Btu/h x 0.969 = 113,567 Btu/h

The corrected heat capacity at 30°F would be: 86,200 Btu/h x 0.913 = 78,701 Btu/h

The corrected pressure drop at 30°F and 30gpm would be: 6.9 ft. hd. x 1.270 = 8.8 ft. hd.



Contractor: \_\_\_\_\_ P.O.: \_\_\_\_\_

Engineer: \_\_\_\_\_

Project Name: \_\_\_\_\_ Unit Tag: \_\_\_\_\_

**Affinity YDL Series**  
**Single Capacity**  
**7 - 30 Tons 60Hz**



## 084 - Part Load - Performance Data

### Capacity Data (1700 CFM)

EWT °F	WATER FLOW GPM	WPD		HEATING - EAT 70 °F					COOLING - EAT 80/67 °F					
		PSI	FT	HC	KW	HE	LAT	COP	TC	SC	S/T	KW	HR	EER
20	8.0	1.6	3.7	Operation not recommended					Operation not recommended					
	10.0	1.8	4.2											
	16.0	3.6	8.3	38.3	3.02	28.0	88.9	3.72						
30	8.0	1.5	3.5	Operation not recommended					Operation not recommended					
	10.0	1.7	3.9	40.4	3.10	29.8	90.0	3.82	73.0	49.6	0.68	1.90	79.5	38.5
	16.0	3.5	8.1	41.0	3.14	30.3	90.3	3.83	74.0	50.6	0.68	1.78	80.1	41.6
40	8.0	1.4	3.2	43.1	3.18	32.3	91.5	3.97	72.1	46.1	0.64	2.10	79.3	34.3
	10.0	1.6	3.7	47.8	3.38	36.2	94.0	4.14	71.1	45.8	0.64	1.99	77.9	35.6
	16.0	3.4	7.9	47.5	3.33	36.1	93.9	4.18	72.0	45.9	0.64	1.84	78.3	39.2
50	8.0	1.3	3.0	52.4	3.43	40.7	96.5	4.47	68.8	42.3	0.61	2.16	76.2	31.9
	10.0	1.5	3.5	52.8	3.45	41.0	96.8	4.48	69.1	42.0	0.61	2.09	76.2	33.0
	16.0	3.3	7.6	54.0	3.52	42.0	97.4	4.50	70.0	41.1	0.59	1.89	76.4	37.0
60	8.0	1.2	2.8	58.3	3.51	46.3	99.8	4.87	65.3	41.0	0.63	2.53	73.9	25.9
	10.0	1.4	3.2	58.7	3.53	46.7	100.0	4.88	65.6	40.9	0.62	2.46	74.0	26.6
	16.0	3.2	7.4	60.1	3.60	47.8	100.7	4.90	66.7	40.9	0.61	2.28	74.4	29.2
70	8.0	1.1	2.5	64.2	3.58	52.0	103.0	5.25	61.8	39.6	0.64	2.89	71.7	21.4
	10.0	1.3	3.0	64.7	3.61	52.4	103.2	5.26	62.2	39.9	0.64	2.84	71.9	21.9
	16.0	3.1	7.2	66.2	3.68	53.7	104.1	5.28	63.3	40.8	0.64	2.67	72.4	23.7
80	8.0	1.0	2.3	70.1	3.63	57.7	106.2	5.66	57.8	37.8	0.65	3.47	69.7	16.7
	10.0	1.2	2.8	71.0	3.67	58.5	106.7	5.67	58.9	38.4	0.65	3.31	70.2	17.8
	16.0	3.0	6.9	72.3	3.73	59.6	107.4	5.69	60.0	39.3	0.66	3.21	70.9	18.7
90	8.0	0.9	2.1	76.1	3.69	63.5	109.4	6.05	53.8	36.0	0.67	4.05	67.7	13.3
	10.0	1.0	2.3	77.2	3.73	64.5	110.1	6.06	55.5	37.0	0.67	3.86	68.7	14.4
	16.0	2.9	6.7	78.4	3.78	65.5	110.7	6.08	56.7	37.9	0.67	3.74	69.4	15.2
100	8.0	0.8	1.8	Operation not recommended					Operation not recommended					
	10.0	0.9	2.1						52.5	34.4	0.65	4.18	66.8	12.6
	16.0	2.8	6.5						53.3	34.7	0.65	4.05	67.2	13.2
110	8.0	0.7	1.6	Operation not recommended					Operation not recommended					
	10.0	0.8	1.8						49.0	30.9	0.63	4.48	64.3	10.9
	16.0	2.7	6.2						50.0	31.4	0.63	4.36	64.9	11.5
120	8.0	0.6	0.0	Operation not recommended					Operation not recommended					
	10.0	0.7	1.6						45.7	29.0	0.63	4.37	60.6	10.5
	16.0	2.6	6.0							29.4	0.63	4.24	61.1	11.0

Interpolation is permissible, extrapolation is not.

All entering air conditions are 80°F DB and 67°F WB in Cooling and 70°F DB in Heating.

All performance data is based upon the lower voltage of dual voltage units.

Operation below 60°F EWT requires optional insulated water/refrigerant circuit.

Operation below 40°F EWT is based upon 15% antifreeze solution.

See performance correction tables for operating conditions other than those listed above.

3/30/21



Contractor: \_\_\_\_\_ P.O.: \_\_\_\_\_

Engineer: \_\_\_\_\_

Project Name: \_\_\_\_\_ Unit Tag: \_\_\_\_\_

## 084 - Full Load - Performance Data

### Capacity Data (2500 CFM)

EWT °F	WATER FLOW GPM	WPD		HEATING - EAT 70 °F					COOLING - EAT 80/67 °F					
		PSI	FT	HC	KW	HE	LAT	COP	TC	SC	S/T	KW	HR	EER
20	10.0	1.8	4.2	Operation not recommended					Operation not recommended					
	16.0	3.6	8.3											
	22.0	7.8	18.0	55.7	4.8	39.2	88.6	3.38						
30	10.0	1.7	3.9	Operation not recommended					Operation not recommended					
	16.0	3.5	8.1	64.1	5.05	46.9	91.8	3.72	93.7	64.3	0.69	3.64	106.1	25.7
	22.0	7.1	16.3	65.1	5.11	47.7	92.1	3.73	95.0	65.6	0.69	3.42	106.7	27.8
40	10.0	1.6	3.7	72.3	5.22	54.5	94.8	4.06	93.6	62.7	0.67	4.12	107.7	22.7
	16.0	3.4	7.9	73.9	5.30	55.8	95.4	4.09	94.9	63.9	0.67	3.81	107.9	24.9
	22.0	6.5	15.0	74.6	5.36	56.3	95.6	4.08	96.8	65.3	0.67	3.62	109.1	26.8
50	10.0	1.5	3.5	81.5	5.46	62.9	98.2	4.37	93.7	61.8	0.66	4.13	107.8	22.7
	16.0	3.3	7.6	82.7	5.53	63.9	98.6	4.39	96.1	63.4	0.66	3.97	109.7	24.2
	22.0	6.0	14.0	84.0	5.60	64.9	99.1	4.40	98.6	65.1	0.66	3.81	111.6	25.9
60	10.0	1.4	3.2	92.0	5.71	72.5	102.1	4.72	91.1	61.0	0.67	4.51	106.5	20.2
	16.0	3.2	7.4	93.5	5.79	73.7	102.6	4.73	93.5	62.6	0.67	4.34	108.3	21.5
	22.0	5.7	13.2	94.9	5.86	74.9	103.1	4.75	95.9	64.2	0.67	4.17	110.1	23.0
70	10.0	1.3	3.0	102.6	5.97	82.2	106.0	5.04	88.5	60.1	0.68	4.90	105.2	18.1
	16.0	3.1	7.2	104.2	6.04	83.6	106.6	5.05	90.8	61.7	0.68	4.71	106.8	19.3
	22.0	5.3	12.3	105.8	6.12	84.9	107.2	5.07	93.1	63.3	0.68	4.52	108.5	20.6
80	10.0	1.2	2.8	113.3	6.21	92.1	110.0	5.35	84.2	57.7	0.68	5.51	103.0	15.3
	16.0	3.0	6.9	115.0	6.29	93.6	110.6	5.36	86.7	59.3	0.68	5.25	104.6	16.5
	22.0	5.1	11.8	116.8	6.37	95.1	111.3	5.37	88.7	60.7	0.68	5.09	106.0	17.4
90	10.0	1.0	2.3	124.0	6.46	101.9	113.9	5.63	80.0	55.2	0.69	6.12	100.9	13.1
	16.0	2.9	6.7	125.9	6.54	103.6	114.6	5.64	82.5	57.0	0.69	5.84	102.5	14.1
	22.0	4.9	11.4	127.8	6.62	105.2	115.3	5.66	84.2	58.1	0.69	5.65	103.5	14.9
100	10.0	0.9	2.1	Operation not recommended					Operation not recommended					
	16.0	2.8	6.5						78.6	55.0	0.70	6.81	101.8	11.5
	22.0	4.8	11.1						79.8	55.4	0.69	6.59	102.3	12.1
110	10.0	0.8	1.8	Operation not recommended					Operation not recommended					
	16.0	2.7	6.2						73.8	52.0	0.70	7.74	100.2	9.5
	22.0	4.7	10.7						75.3	52.7	0.70	7.53	101.0	10.0
120	10.0	0.7	1.6	Operation not recommended					Operation not recommended					
	16.0	2.6	6.0						69.4	50.3	0.72	8.65	98.9	8.0
	22.0	4.5	10.4						70.9	51.0	0.72	8.40	99.5	8.4

Interpolation is permissible, extrapolation is not.

3/30/21

All entering air conditions are 80°F DB and 67°F WB in Cooling and 70°F DB in Heating.

All performance data is based upon the lower voltage of dual voltage units.

Operation below 60°F EWT requires optional insulated water/refrigerant circuit.

Operation below 40°F EWT is based upon 15% antifreeze solution.

See performance correction tables for operating conditions other than those listed above.

Contractor: \_\_\_\_\_ P.O.: \_\_\_\_\_

Engineer: \_\_\_\_\_

Project Name: \_\_\_\_\_ Unit Tag: \_\_\_\_\_

**Affinity YDL Series**  
**Single Capacity**  
**7 - 30 Tons 60Hz**



## 096 - Min Load - Performance Data

### Capacity Data (1900 CFM)

EWT °F	WATER FLOW GPM	WPD		HEATING - EAT 70 °F					COOLING - EAT 80/67 °F					
		PSI	FT	HC	KW	HE	LAT	COP	TC	SC	S/T	KW	HR	EER
20	12.0	1.5	3.5	Operation not recommended					Operation not recommended					
	16.0	2.4	5.5	Operation not recommended					Operation not recommended					
	18.0	2.9	6.7	39.0	3.28	27.8	87.0	3.48	Operation not recommended					
30	12.0	1.4	3.2	Operation not recommended					Operation not recommended					
	16.0	2.3	5.3	45.4	3.36	33.9	90.1	3.96	80.5	52.2	0.65	2.11	87.7	38.2
	18.0	2.8	6.5	46.1	3.40	34.5	90.5	3.97	81.6	53.3	0.65	1.98	88.4	41.2
40	12.0	1.3	3.0	51.5	3.56	39.3	93.1	4.23	75.3	49.5	0.66	2.32	83.2	32.5
	16.0	2.2	5.1	52.7	3.72	40.0	93.7	4.15	78.1	51.5	0.66	2.24	85.7	34.9
	18.0	2.7	6.2	53.1	3.66	40.6	93.9	4.25	79.3	52.4	0.66	2.14	86.6	37.1
50	12.0	1.2	2.8	58.2	3.81	45.2	96.4	4.47	73.2	48.9	0.67	2.49	81.7	29.4
	16.0	2.1	4.9	59.4	3.88	46.2	96.9	4.49	75.7	50.7	0.67	2.36	83.8	32.0
	18.0	2.6	6.0	60.0	3.91	46.7	97.2	4.50	77.0	51.6	0.67	2.30	84.8	33.5
60	12.0	1.1	2.5	66.3	3.98	52.7	100.3	4.88	69.0	47.2	0.68	2.88	78.8	24.0
	16.0	2.0	4.6	67.7	4.05	53.8	101.0	4.90	71.5	48.8	0.68	2.73	80.8	26.2
	18.0	2.5	5.8	68.3	4.08	54.4	101.3	4.91	72.7	49.7	0.68	2.66	81.7	27.4
70	12.0	1.0	2.3	74.4	4.15	60.2	104.2	5.25	64.9	45.4	0.70	3.26	76.0	19.9
	16.0	1.9	4.4	75.9	4.22	61.5	105.0	5.27	67.2	47.0	0.70	3.09	77.7	21.7
	18.0	2.4	5.5	76.7	4.26	62.2	105.4	5.28	68.3	47.7	0.70	3.01	78.6	22.7
80	12.0	0.9	2.1	82.5	4.28	67.9	108.2	5.65	61.8	44.5	0.72	3.89	75.0	15.9
	16.0	1.8	4.2	83.9	4.34	69.1	108.9	5.66	63.8	45.9	0.72	3.71	76.5	17.2
	18.0	2.3	5.3	85.0	4.39	70.0	109.4	5.68	65.0	46.8	0.72	3.60	77.3	18.1
90	12.0	0.8	1.8	90.5	4.41	75.5	112.1	6.02	58.6	43.5	0.74	4.53	74.0	12.9
	16.0	1.7	3.9	91.9	4.47	76.7	112.8	6.03	60.4	44.9	0.74	4.32	75.2	14.0
	18.0	2.2	5.1	93.3	4.52	77.9	113.5	6.05	61.7	45.9	0.74	4.18	75.9	14.8
100	12.0	0.7	1.6	Operation not recommended					Operation not recommended					
	16.0	1.6	3.7	Operation not recommended					57.5	44.4	0.77	4.75	73.7	12.1
	18.0	2.1	4.9	Operation not recommended					58.3	44.7	0.77	4.60	74.0	12.7
110	12.0	0.6	1.4	Operation not recommended					Operation not recommended					
	16.0	1.5	3.5	Operation not recommended					53.9	42.9	0.80	5.15	71.5	10.5
	18.0	2.0	4.6	Operation not recommended					55.0	43.5	0.79	5.01	72.1	11.0
120	12.0	0.5	1.2	Operation not recommended					Operation not recommended					
	16.0	1.4	3.2	Operation not recommended					50.6	42.2	0.83	5.87	70.6	8.6
	18.0	1.9	4.4	Operation not recommended					51.7	42.8	0.83	5.70	71.1	9.1

Interpolation is permissible, extrapolation is not.

3/30/21

All entering air conditions are 80°F DB and 67°F WB in Cooling and 70°F DB in Heating.

All performance data is based upon the lower voltage of dual voltage units.

Operation below 60°F EWT requires optional insulated water/refrigerant circuit.

Operation below 40°F EWT is based upon 15% antifreeze solution.

See performance correction tables for operating conditions other than those listed above.



Contractor: \_\_\_\_\_ P.O.: \_\_\_\_\_

Engineer: \_\_\_\_\_

Project Name: \_\_\_\_\_ Unit Tag: \_\_\_\_\_

## 096 - Full Load - Performance Data

### Capacity Data (2800 CFM)

EWT °F	WATER FLOW GPM	WPD		HEATING - EAT 70 °F					COOLING - EAT 80/67 °F					
		PSI	FT	HC	KW	HE	LAT	COP	TC	SC	S/T	KW	HR	EER
20	12.0	1.5	3.5	Operation not recommended					Operation not recommended					
	18.0	2.9	6.7											
	24.0	5.0	11.6	62.7	5.40	44.3	88.7	3.40						
30	12.0	1.4	3.2	Operation not recommended					Operation not recommended					
	18.0	2.8	6.5	72.7	5.73	53.1	92.0	3.72	102.6	71.6	0.70	4.21	116.9	24.4
	24.0	4.9	11.3	73.8	5.80	54.0	92.4	3.73	104.0	73.0	0.70	3.95	117.5	26.3
40	12.0	1.3	3.0	82.3	5.94	62.1	95.2	4.06	100.7	69.5	0.69	4.57	116.3	22.0
	18.0	2.7	6.2	83.9	5.99	63.4	95.7	4.10	103.9	71.2	0.69	4.44	119.1	23.4
	24.0	4.8	11.1	84.9	6.10	64.1	96.1	4.08	106.0	72.8	0.69	4.22	120.4	25.1
50	12.0	1.2	2.8	93.1	6.23	71.9	98.8	4.38	102.6	69.0	0.67	4.86	119.2	21.1
	18.0	2.6	6.0	94.6	6.31	73.0	99.3	4.39	105.3	70.8	0.67	4.68	121.3	22.5
	24.0	4.6	10.5	96.0	6.39	74.2	99.7	4.40	108.0	72.6	0.67	4.49	123.3	24.1
60	12.0	1.1	2.5	106.1	6.58	83.6	103.1	4.73	99.3	67.2	0.68	5.32	117.5	18.7
	18.0	2.5	5.8	107.7	6.66	85.0	103.6	4.74	101.9	69.0	0.68	5.12	119.4	19.9
	24.0	4.5	10.4	109.3	6.75	86.3	104.2	4.75	104.6	70.8	0.68	4.92	121.3	21.3
70	12.0	1.0	2.3	119.0	6.92	95.4	107.3	5.04	96.0	65.3	0.68	5.78	115.8	16.6
	18.0	2.4	5.5	120.8	7.01	96.9	108.0	5.05	98.6	67.1	0.68	5.56	117.6	17.7
	24.0	4.4	10.2	122.7	7.10	98.4	108.6	5.06	101.1	69.0	0.68	5.34	119.3	18.9
80	12.0	0.9	2.1	126.4	7.21	101.8	109.8	5.14	92.5	64.0	0.69	6.40	114.4	14.5
	18.0	2.3	5.3	128.4	7.30	103.5	110.5	5.15	95.2	65.9	0.69	6.11	116.0	15.6
	24.0	4.3	9.9	130.3	7.39	105.1	111.1	5.17	97.4	67.3	0.69	5.91	117.5	16.5
90	12.0	0.8	1.8	133.9	7.49	108.3	112.3	5.24	89.0	62.7	0.70	7.02	112.9	12.7
	18.0	2.2	5.1	135.9	7.59	110.0	113.0	5.25	91.8	64.6	0.70	6.70	114.6	13.7
	24.0	4.2	9.7	138.0	7.68	111.8	113.6	5.27	93.7	65.6	0.70	6.48	115.8	14.5
100	12.0	0.7	1.6	Operation not recommended					Operation not recommended					
	18.0	2.1	4.9						89.0	63.4	0.71	7.54	114.7	11.8
	24.0	4.1	9.5						90.3	63.9	0.71	7.30	115.3	12.4
110	12.0	0.6	1.4	Operation not recommended					Operation not recommended					
	18.0	2.0	4.6						85.3	61.3	0.72	8.35	113.8	10.2
	24.0	4.0	9.2						87.0	62.2	0.71	8.12	114.7	10.7
120	12.0	0.5	1.2	Operation not recommended					Operation not recommended					
	18.0	1.9	4.4						81.9	60.2	0.73	9.66	114.9	8.5
	24.0	3.9	9.0						83.7	61.1	0.73	9.38	115.7	8.9

Interpolation is permissible, extrapolation is not.

3/30/21

All entering air conditions are 80°F DB and 67°F WB in Cooling and 70°F DB in Heating.

All performance data is based upon the lower voltage of dual voltage units.

Operation below 60°F EWT requires optional insulated water/refrigerant circuit.

Operation below 40°F EWT is based upon 15% antifreeze solution.

See performance correction tables for operating conditions other than those listed above.

Contractor: \_\_\_\_\_ P.O.: \_\_\_\_\_

Engineer: \_\_\_\_\_

Project Name: \_\_\_\_\_ Unit Tag: \_\_\_\_\_

**Affinity YDL Series**  
**Single Capacity**  
**7 - 30 Tons 60Hz**



## 120 - Part Load - Performance Data

### Capacity Data (2400 CFM)

EWT °F	WATER FLOW GPM	WPD		HEATING - EAT 70 °F					COOLING - EAT 80/67 °F					
		PSI	FT	HC	KW	HE	LAT	COP	TC	SC	S/T	KW	HR	EER
20	12.0	0.4	1.0	Operation not recommended					Operation not recommended					
	16.0	0.8	1.9											
	20.0	1.4	3.2	45.5	4.01	31.8	85.6	3.33						
30	12.0	0.4	1.0	Operation not recommended					Operation not recommended					
	16.0	0.8	1.8	53.2	4.05	39.4	88.5	3.85	95.4	58.8	0.62	3.31	106.7	28.8
	20.0	1.4	3.1	54.0	4.10	40.0	88.8	3.86	96.7	60.0	0.62	3.11	107.3	31.1
40	12.0	0.4	0.9	60.1	4.32	45.4	91.2	4.08	90.6	56.2	0.62	3.50	102.5	25.9
	16.0	0.8	1.8	61.1	4.38	46.1	91.6	4.09	93.5	58.3	0.62	3.40	105.1	27.5
	20.0	1.3	3.0	62.0	4.44	46.9	91.9	4.10	95.4	59.6	0.62	3.23	106.4	29.5
50	12.0	0.4	0.8	67.9	4.65	52.0	94.2	4.28	89.3	56.3	0.63	3.62	101.7	24.7
	16.0	0.7	1.7	69.0	4.71	52.9	94.6	4.29	91.7	57.7	0.63	3.48	103.5	26.3
	20.0	1.2	2.8	70.0	4.77	53.7	95.0	4.30	94.0	59.2	0.63	3.34	105.4	28.1
60	12.0	0.3	0.8	76.8	4.76	60.5	97.6	4.73	86.1	55.1	0.64	3.82	99.1	22.6
	16.0	0.7	1.6	78.0	4.82	61.5	98.1	4.74	88.4	56.5	0.64	3.67	100.9	24.1
	20.0	1.2	2.7	79.2	4.88	62.5	98.5	4.75	90.7	58.0	0.64	3.52	102.7	25.7
70	12.0	0.3	0.7	85.7	4.87	69.1	101.0	5.16	83.0	53.9	0.65	4.01	96.6	20.7
	16.0	0.7	1.5	87.0	4.93	70.2	101.6	5.17	85.1	55.3	0.65	3.85	98.3	22.1
	20.0	1.1	2.6	88.3	4.99	71.3	102.1	5.19	87.3	56.8	0.65	3.70	100.0	23.6
80	12.0	0.3	0.7	94.6	4.94	77.7	104.5	5.61	75.9	49.9	0.66	4.84	92.4	15.7
	16.0	0.6	1.5	96.0	5.00	79.0	105.1	5.63	78.1	51.3	0.66	4.61	93.8	16.9
	20.0	1.1	2.5	97.5	5.07	80.2	105.6	5.64	79.9	52.5	0.66	4.47	95.1	17.9
90	12.0	0.3	0.6	103.5	5.01	86.4	107.9	6.05	68.9	45.9	0.67	5.67	88.2	12.2
	16.0	0.6	1.4	105.1	5.08	87.8	108.5	6.07	71.1	47.3	0.67	5.40	89.5	13.1
	20.0	1.1	2.5	106.7	5.14	89.2	109.2	6.08	72.5	48.2	0.67	5.23	90.3	13.9
100	12.0	0.2	0.5	Operation not recommended					Operation not recommended					
	16.0	0.5	1.2						64.2	44.3	0.69	5.71	83.7	11.2
	20.0	1.0	2.3						65.2	44.6	0.69	5.53	84.0	11.8
110	12.0	0.2	0.4	Operation not recommended					Operation not recommended					
	16.0	0.5	1.2						56.6	40.4	0.71	5.99	77.1	9.5
	20.0	1.0	2.2						57.8	41.0	0.71	5.83	77.7	9.9
120	12.0	0.2	0.4	Operation not recommended					Operation not recommended					
	16.0	0.5	1.2						54.2	39.3	0.72	6.31	75.8	8.6
	20.0	0.9	2.2						55.4	39.9	0.72	6.13	76.3	9.0

Interpolation is permissible, extrapolation is not.  
 All entering air conditions are 80°F DB and 67°F WB in Cooling and 70°F DB in Heating.  
 All performance data is based upon the lower voltage of dual voltage units.  
 Operation below 60°F EWT requires optional insulated water/refrigerant circuit.  
 Operation below 40°F EWT is based upon 15% antifreeze solution.  
 See performance correction tables for operating conditions other than those listed above.

3/30/21

The manufacturer works continually to improve its products. As a result, the design and specifications of each product at the time of order may be changed without notice. Purchaser's approval of this data set signifies that the equipment is acceptable under the provisions of the job specification. Statements and other information contained herein are not express warranties and do not form the basis of any bargain between the parties, but are merely the manufacturer's opinion or commendation of its products. York and Affinity are registered trademarks of Johnson Controls, Inc., and are used with permission.

Contractor: \_\_\_\_\_ P.O.: \_\_\_\_\_

Engineer: \_\_\_\_\_

Project Name: \_\_\_\_\_ Unit Tag: \_\_\_\_\_

**Affinity YDL Series**  
**Single Capacity**  
**7 - 30 Tons 60Hz**



## 120 - Full Load - Performance Data

### Capacity Data (3600 CFM)

EWT °F	WATER FLOW GPM	WPD		HEATING - EAT 70 °F					COOLING - EAT 80/67 °F					
		PSI	FT	HC	KW	HE	LAT	COP	TC	SC	S/T	KW	HR	EER
20	16.0	0.8	1.8	Operation not recommended					Operation not recommended					
	22.0	1.6	3.7	Operation not recommended					Operation not recommended					
	30.0	3.1	7.2	72.3	7.0	48.4	86.6	3.03						
30	16.0	0.8	1.8	Operation not recommended					Operation not recommended					
	22.0	1.5	3.5	84.9	7.30	60.0	89.8	3.41	142.3	96.0	0.68	5.83	162.1	24.4
	30.0	3.0	6.9	86.2	7.39	61.0	90.2	3.42	144.2	97.9	0.68	5.47	162.9	26.4
40	16.0	0.8	1.8	97.1	7.48	71.6	93.0	3.80	135.5	92.1	0.68	6.25	156.8	21.7
	22.0	1.4	3.2	100.3	7.72	74.0	93.8	3.81	139.6	95.3	0.68	6.09	160.4	22.9
	30.0	2.9	6.7	100.1	7.68	73.9	93.7	3.82	142.6	97.6	0.68	5.77	162.3	24.7
50	16.0	0.7	1.6	110.6	7.76	84.1	96.4	4.18	134.0	92.5	0.69	6.56	156.4	20.4
	22.0	1.3	3.0	112.0	7.85	85.3	96.8	4.19	137.0	94.5	0.69	6.35	158.7	21.6
	30.0	2.8	6.5	114.0	7.96	86.8	97.3	4.20	141.1	97.3	0.69	6.06	161.7	23.3
60	16.0	0.7	1.6	124.6	7.89	97.7	100.0	4.63	127.6	89.3	0.70	7.06	151.7	18.1
	22.0	1.3	3.0	126.2	7.98	99.0	100.5	4.64	130.5	91.3	0.70	6.83	153.8	19.1
	30.0	2.7	6.2	128.4	8.10	100.8	101.0	4.65	134.4	94.0	0.70	6.52	156.6	20.6
70	16.0	0.7	1.6	138.6	8.02	111.2	103.6	5.06	121.3	86.1	0.71	7.55	147.0	16.1
	22.0	1.2	2.8	140.4	8.11	112.8	104.1	5.07	124.0	88.1	0.71	7.30	148.9	17.0
	30.0	2.6	5.9	142.9	8.23	114.8	104.8	5.09	127.7	90.6	0.71	6.97	151.5	18.3
80	16.0	0.6	1.4	152.6	8.21	124.6	107.3	5.45	116.3	84.3	0.72	8.46	145.2	13.8
	22.0	1.2	2.8	154.8	8.31	126.5	107.8	5.46	119.4	86.5	0.72	8.06	147.0	14.8
	30.0	2.5	5.8	157.3	8.42	128.6	108.5	5.48	122.4	88.5	0.72	7.81	149.1	15.7
90	16.0	0.6	1.4	166.6	8.39	138.0	110.9	5.82	111.4	82.4	0.74	9.36	143.3	11.9
	22.0	1.2	2.8	169.2	8.51	140.2	111.5	5.83	114.9	85.0	0.74	8.93	145.3	12.9
	30.0	2.4	5.5	171.8	8.61	142.4	112.2	5.85	117.2	86.3	0.74	8.64	146.7	13.6
100	16.0	0.5	1.2	Operation not recommended					Operation not recommended					
	22.0	1.1	2.5	Operation not recommended					111.1	83.1	0.75	10.19	145.8	10.9
	30.0	2.3	5.3	Operation not recommended					112.8	83.8	0.74	9.86	146.4	11.4
110	16.0	0.5	1.2	Operation not recommended					Operation not recommended					
	22.0	1.1	2.5	Operation not recommended					106.2	80.1	0.75	11.39	145.0	9.3
	30.0	2.2	5.1	Operation not recommended					108.3	81.2	0.75	11.08	146.1	9.8
120	16.0	0.5	1.2	Operation not recommended					Operation not recommended					
	22.0	1.0	2.3	Operation not recommended					101.7	77.8	0.76	12.73	145.1	8.0
	30.0	2.1	4.9	Operation not recommended					103.9	79.0	0.76	12.36	146.1	8.4

Interpolation is permissible, extrapolation is not.

3/30/21

All entering air conditions are 80°F DB and 67°F WB in Cooling and 70°F DB in Heating.

All performance data is based upon the lower voltage of dual voltage units.

Operation below 60°F EWT requires optional insulated water/refrigerant circuit.

Operation below 40°F EWT is based upon 15% antifreeze solution.

See performance correction tables for operating conditions other than those listed above.

The manufacturer works continually to improve its products. As a result, the design and specifications of each product at the time of order may be changed without notice. Purchaser's approval of this data set signifies that the equipment is acceptable under the provisions of the job specification. Statements and other information contained herein are not express warranties and do not form the basis of any bargain between the parties, but are merely the manufacturer's opinion or commendation of its products. York and Affinity are registered trademarks of Johnson Controls, Inc., and are used with permission.

Contractor: \_\_\_\_\_ P.O.: \_\_\_\_\_

Engineer: \_\_\_\_\_

Project Name: \_\_\_\_\_ Unit Tag: \_\_\_\_\_

**Affinity YDL Series**  
**Single Capacity**  
**7 - 30 Tons 60Hz**



## 150 - Part Load - Performance Data

### Capacity Data (2300 CFM)

EWT °F	WATER FLOW GPM	WPD		HEATING - EAT 70 °F					COOLING - EAT 80/67 °F					
		PSI	FT	HC	KW	HE	LAT	COP	TC	SC	S/T	KW	HR	EER
20	12.0	1.7	3.9	Operation not recommended					Operation not recommended					
	15.0	2.1	4.9	Operation not recommended					Operation not recommended					
	18.0	2.5	5.8	28.0	2.42	19.7	79.3	3.39	Operation not recommended					
30	12.0	1.6	3.7	Operation not recommended					Operation not recommended					
	15.0	2.0	4.6	36.7	3.18	25.8	82.8	3.38	85.4	62.9	0.74	3.25	96.5	26.3
	18.0	2.4	5.5	37.2	3.22	26.2	83.0	3.39	86.6	64.1	0.74	3.05	97.0	28.4
40	12.0	1.5	3.5	49.6	3.63	37.2	88.0	4.00	85.8	63.5	0.74	3.68	98.3	23.3
	15.0	1.9	4.4	57.2	3.95	43.8	91.0	4.24	84.7	63.0	0.74	3.44	96.5	24.7
	18.0	2.3	5.3	51.1	3.73	38.4	88.6	4.02	85.7	63.8	0.74	3.22	96.7	26.6
50	12.0	1.4	3.2	63.1	4.12	49.0	93.4	4.48	83.3	62.5	0.75	3.86	96.5	21.6
	15.0	1.8	4.2	64.0	4.18	49.8	93.8	4.49	84.0	63.0	0.75	3.63	96.4	23.2
	18.0	2.2	5.1	65.0	4.23	50.6	94.2	4.50	84.8	63.6	0.75	3.39	96.3	25.0
60	12.0	1.3	3.0	71.1	4.37	56.2	96.6	4.77	80.1	60.9	0.76	4.15	94.3	19.3
	15.0	1.7	3.9	72.2	4.42	57.1	97.1	4.79	81.2	61.7	0.76	3.89	94.5	20.9
	18.0	2.1	4.9	73.3	4.48	58.0	97.5	4.80	82.3	62.5	0.76	3.63	94.6	22.7
70	12.0	1.2	2.8	79.2	4.61	63.5	99.9	5.03	77.0	59.3	0.77	4.43	92.1	17.4
	15.0	1.6	3.7	80.4	4.67	64.5	100.4	5.05	78.4	60.3	0.77	4.15	92.5	18.9
	18.0	2.0	4.6	81.7	4.73	65.5	100.9	5.06	79.8	61.4	0.77	3.87	93.0	20.6
80	12.0	1.1	2.5	87.3	4.81	70.9	103.1	5.32	73.5	57.3	0.78	4.82	89.9	15.3
	15.0	1.5	3.5	88.7	4.87	72.0	103.7	5.33	75.3	58.7	0.78	4.59	90.9	16.4
	18.0	1.9	4.4	90.0	4.94	73.2	104.2	5.34	76.7	59.8	0.78	4.45	91.9	17.3
90	12.0	1.0	2.3	95.4	5.01	78.3	106.4	5.58	70.0	55.3	0.79	5.44	88.5	12.9
	15.0	1.4	3.2	96.9	5.08	79.5	107.0	5.59	72.2	57.0	0.79	5.19	89.9	13.9
	18.0	1.8	4.2	98.3	5.14	80.8	107.6	5.61	73.7	58.2	0.79	5.02	90.8	14.7
100	12.0	0.9	2.1	Operation not recommended					Operation not recommended					
	15.0	1.3	3.0	Operation not recommended					68.1	54.6	0.80	5.58	87.1	12.2
	18.0	1.7	3.9	Operation not recommended					69.1	55.1	0.80	5.40	87.5	12.8
110	12.0	0.8	1.8	Operation not recommended					Operation not recommended					
	15.0	1.2	2.8	Operation not recommended					63.3	51.1	0.81	5.94	83.5	10.6
	18.0	1.6	3.7	Operation not recommended					64.5	51.9	0.80	5.78	84.3	11.2
120	12.0	0.7	1.6	Operation not recommended					Operation not recommended					
	15.0	1.1	2.5	Operation not recommended					59.9	49.4	0.82	6.78	83.0	8.8
	18.0	1.5	3.5	Operation not recommended					61.2	50.1	0.82	6.58	83.6	9.3

Interpolation is permissible, extrapolation is not.

3/30/21

All entering air conditions are 80°F DB and 67°F WB in Cooling and 70°F DB in Heating.

All performance data is based upon the lower voltage of dual voltage units.

Operation below 60°F EWT requires optional insulated water/refrigerant circuit.

Operation below 40°F EWT is based upon 15% antifreeze solution.

See performance correction tables for operating conditions other than those listed above.

The manufacturer works continually to improve its products. As a result, the design and specifications of each product at the time of order may be changed without notice. Purchaser's approval of this data set signifies that the equipment is acceptable under the provisions of the job specification. Statements and other information contained herein are not express warranties and do not form the basis of any bargain between the parties, but are merely the manufacturer's opinion or commendation of its products. York and Affinity are registered trademarks of Johnson Controls, Inc., and are used with permission.

Contractor: \_\_\_\_\_ P.O.: \_\_\_\_\_

Engineer: \_\_\_\_\_

Project Name: \_\_\_\_\_ Unit Tag: \_\_\_\_\_

**Affinity YDL Series**  
**Single Capacity**  
**7 - 30 Tons 60Hz**



## 150 - Full Load - Performance Data

### Capacity Data (4500 CFM)

EWT °F	WATER FLOW GPM	WPD		HEATING - EAT 70 °F					COOLING - EAT 80/67 °F					
		PSI	FT	HC	KW	HE	LAT	COP	TC	SC	S/T	KW	HR	EER
20	24.0	3.3	7.6	Operation not recommended					Operation not recommended					
	30.0	5.2	12.0											
	36.0	7.0	16.2	88.3	9.10	57.3	88.4	2.84						
30	24.0	3.2	7.4	Operation not recommended					Operation not recommended					
	30.0	5.1	11.8	95.1	9.16	63.8	87.6	3.04	171.8	111.1	0.65	6.46	193.9	26.6
	36.0	6.9	15.9	100.1	9.22	68.6	88.6	3.18	174.2	113.2	0.65	6.07	194.9	28.7
40	24.0	3.1	7.2	111.6	9.03	80.8	91.0	3.62	171.5	111.5	0.65	7.45	196.9	23.0
	30.0	5.0	11.6	114.5	9.22	83.0	91.6	3.64	170.0	110.8	0.65	6.96	193.7	24.4
	36.0	6.8	15.7	115.1	9.26	83.5	91.7	3.64	171.9	112.2	0.65	6.51	194.1	26.4
50	24.0	3.0	6.9	126.1	9.07	95.2	93.9	4.08	166.6	110.0	0.66	7.95	193.7	21.0
	30.0	4.9	11.3	128.1	9.18	96.7	94.3	4.09	168.1	110.6	0.66	7.45	193.5	22.6
	36.0	6.7	15.5	130.0	9.30	98.3	94.7	4.10	169.5	111.2	0.66	6.95	193.2	24.4
60	24.0	2.9	6.7	142.3	9.55	109.7	97.3	4.37	160.3	107.3	0.67	8.49	189.2	18.9
	30.0	4.8	11.1	144.5	9.67	111.5	97.7	4.38	162.4	108.5	0.67	8.07	189.9	20.1
	36.0	6.6	15.2	146.7	9.79	113.2	98.2	4.39	164.5	109.6	0.67	7.65	190.6	21.5
70	24.0	2.8	6.5	158.4	10.02	124.2	100.6	4.63	153.9	104.7	0.68	9.04	184.7	17.0
	30.0	4.7	10.9	160.9	10.15	126.2	101.1	4.64	156.7	106.4	0.68	8.69	186.4	18.0
	36.0	6.5	15.0	163.3	10.28	128.2	101.6	4.66	159.5	108.1	0.68	8.34	188.0	19.1
80	24.0	2.7	6.2	174.6	10.42	139.0	103.9	4.91	146.9	104.1	0.71	9.90	180.7	14.8
	30.0	4.6	10.6	177.3	10.56	141.3	104.5	4.92	150.5	106.6	0.71	9.44	182.8	15.9
	36.0	6.4	14.8	180.0	10.69	143.5	105.0	4.93	153.4	108.6	0.71	9.14	184.6	16.8
90	24.0	2.6	6.0	190.8	10.82	153.8	107.3	5.17	140.0	103.6	0.74	10.77	176.7	13.0
	30.0	4.5	10.4	193.7	10.97	156.3	107.9	5.18	144.4	106.8	0.74	10.27	179.4	14.1
	36.0	6.3	14.6	196.7	11.10	158.8	108.5	5.19	147.3	109.1	0.74	9.94	181.2	14.8
100	24.0	2.5	5.8	Operation not recommended					Operation not recommended					
	30.0	4.4	10.2						138.6	103.2	0.74	11.39	177.4	12.2
	36.0	6.2	14.3						140.7	104.1	0.74	11.02	178.3	12.8
110	24.0	2.4	5.5	Operation not recommended					Operation not recommended					
	30.0	4.3	9.9						131.3	97.5	0.74	12.44	173.8	10.6
	36.0	6.1	14.1						134.0	99.0	0.74	12.10	175.3	11.1
120	24.0	2.3	5.3	Operation not recommended					Operation not recommended					
	30.0	4.2	9.7						124.7	93.2	0.75	14.33	173.5	8.7
	36.0	6.0	13.9						127.3	94.6	0.74	13.91	174.8	9.2

Interpolation is permissible, extrapolation is not.

3/30/21

All entering air conditions are 80°F DB and 67°F WB in Cooling and 70°F DB in Heating.

All performance data is based upon the lower voltage of dual voltage units.

Operation below 60°F EWT requires optional insulated water/refrigerant circuit.

Operation below 40°F EWT is based upon 15% antifreeze solution.

See performance correction tables for operating conditions other than those listed above.

The manufacturer works continually to improve its products. As a result, the design and specifications of each product at the time of order may be changed without notice. Purchaser's approval of this data set signifies that the equipment is acceptable under the provisions of the job specification. Statements and other information contained herein are not express warranties and do not form the basis of any bargain between the parties, but are merely the manufacturer's opinion or commendation of its products. York and Affinity are registered trademarks of Johnson Controls, Inc., and are used with permission.





Contractor: \_\_\_\_\_ P.O.: \_\_\_\_\_

Engineer: \_\_\_\_\_

Project Name: \_\_\_\_\_ Unit Tag: \_\_\_\_\_

## 180 - Part Load - Performance Data

### Capacity Data (2800 CFM)

EWT °F	WATER FLOW GPM	WPD		HEATING - EAT 70 °F					COOLING - EAT 80/67 °F					
		PSI	FT	HC	KW	HE	LAT	COP	TC	SC	S/T	KW	HR	EER
20	20.0	1.7	3.9	Operation not recommended					Operation not recommended					
	24.0	2.2	5.1											
	28.0	2.6	6.0	45.0	4.32	30.3	82.9	3.05						
30	20.0	1.6	3.7	Operation not recommended					Operation not recommended					
	24.0	2.1	4.9	53.4	4.79	37.0	85.6	3.27	100.0	69.6	0.70	3.71	112.7	27.0
	28.0	2.5	5.8	55.0	4.91	38.2	86.2	3.28	101.4	71.0	0.70	3.48	113.3	29.1
40	20.0	1.5	3.5	63.1	5.07	45.7	88.8	3.64	94.2	67.9	0.72	4.12	108.3	22.9
	24.0	2.0	4.6	66.4	5.26	48.4	89.9	3.70	97.3	69.8	0.72	4.00	111.0	24.3
	28.0	2.4	5.5	65.0	5.21	47.2	89.5	3.66	99.2	71.3	0.72	3.81	112.2	26.1
50	20.0	1.4	3.2	72.8	5.36	54.5	92.1	3.98	92.2	68.2	0.74	4.47	107.4	20.6
	24.0	1.9	4.4	73.9	5.43	55.3	92.4	3.99	94.6	69.9	0.74	4.30	109.3	22.0
	28.0	2.3	5.3	75.0	5.50	56.2	92.8	4.00	97.0	71.7	0.74	4.13	111.1	23.5
60	20.0	1.3	3.0	81.6	5.54	62.7	95.0	4.32	89.9	66.1	0.74	4.99	107.0	18.0
	24.0	1.8	4.2	82.9	5.61	63.8	95.4	4.33	92.3	67.9	0.74	4.80	108.7	19.2
	28.0	2.2	5.1	84.2	5.68	64.8	95.8	4.34	94.7	69.7	0.74	4.61	110.4	20.5
70	20.0	1.2	2.8	90.5	5.71	71.0	97.9	4.64	87.7	64.0	0.73	5.51	106.5	15.9
	24.0	1.7	3.9	91.9	5.79	72.2	98.4	4.66	90.0	65.8	0.73	5.30	108.1	17.0
	28.0	2.1	4.9	93.3	5.86	73.3	98.9	4.67	92.3	67.6	0.73	5.09	109.7	18.1
80	20.0	1.1	2.5	99.4	5.88	79.4	100.9	4.96	84.5	63.4	0.75	6.03	105.1	14.0
	24.0	1.6	3.7	101.0	5.96	80.7	101.4	4.97	87.0	65.2	0.75	5.76	106.6	15.1
	28.0	2.0	4.6	102.5	6.03	81.9	101.9	4.98	89.0	66.9	0.75	5.57	108.0	16.0
90	20.0	1.0	2.3	108.3	6.05	87.7	103.8	5.25	81.4	62.7	0.77	6.55	103.7	12.4
	24.0	1.5	3.5	110.0	6.12	89.1	104.4	5.26	84.0	64.6	0.77	6.25	105.3	13.4
	28.0	1.9	4.4	111.7	6.20	90.5	104.9	5.28	85.7	66.1	0.77	6.05	106.3	14.2
100	20.0	0.9	2.1	Operation not recommended					Operation not recommended					
	24.0	1.4	3.2						81.1	63.7	0.79	6.75	104.1	12.0
	28.0	1.8	4.2						82.3	64.2	0.78	6.54	104.6	12.6
110	20.0	0.8	1.8	Operation not recommended					Operation not recommended					
	24.0	1.3	3.0						77.4	61.4	0.79	7.22	102.0	10.7
	28.0	1.7	3.9						79.0	62.3	0.79	7.02	103.0	11.3
120	20.0	0.7	1.6	Operation not recommended					Operation not recommended					
	24.0	1.2	2.8						74.6	60.1	0.81	7.93	101.7	9.4
	28.0	1.6	3.7						76.2	61.0	0.80	7.70	102.5	9.9

Interpolation is permissible, extrapolation is not.

3/30/21

All entering air conditions are 80°F DB and 67°F WB in Cooling and 70°F DB in Heating.

All performance data is based upon the lower voltage of dual voltage units.

Operation below 60°F EWT requires optional insulated water/refrigerant circuit.

Operation below 40°F EWT is based upon 15% antifreeze solution.

See performance correction tables for operating conditions other than those listed above.



Contractor: \_\_\_\_\_ P.O.: \_\_\_\_\_

Engineer: \_\_\_\_\_

Project Name: \_\_\_\_\_ Unit Tag: \_\_\_\_\_

## 180 - Full Load - Performance Data

### Capacity Data (5200 CFM)

EWT °F	WATER FLOW GPM	WPD		HEATING - EAT 70 °F					COOLING - EAT 80/67 °F					
		PSI	FT	HC	KW	HE	LAT	COP	TC	SC	S/T	KW	HR	EER
20	22.0	1.9	4.4	Operation not recommended					Operation not recommended					
	34.0	3.1	7.2											
	45.0	4.3	9.9	105.3	11.00	67.8	86.8	2.81						
30	22.0	1.8	4.2	Operation not recommended					Operation not recommended					
	34.0	3.0	6.9	122.4	11.50	83.2	89.8	3.12	195.8	129.4	0.66	9.19	227.1	21.3
	45.0	4.2	9.7	124.3	11.64	84.6	90.1	3.13	199.8	131.9	0.66	8.89	230.1	22.5
40	22.0	1.7	3.9	138.9	11.77	98.7	92.7	3.46	186.6	125.0	0.67	10.20	221.4	18.3
	34.0	2.9	6.7	144.4	11.95	103.7	93.7	3.54	192.1	128.8	0.67	9.77	225.4	19.7
	45.0	4.1	9.5	143.2	12.07	102.0	93.5	3.48	196.4	131.6	0.67	9.42	228.5	20.8
50	22.0	1.6	3.7	157.1	12.19	115.6	96.0	3.78	183.4	124.7	0.68	10.78	220.1	17.0
	34.0	2.8	6.5	159.7	12.35	117.5	96.4	3.79	188.4	128.1	0.68	10.35	223.7	18.2
	45.0	4.0	9.2	162.0	12.50	119.4	96.8	3.80	193.0	131.3	0.68	9.95	226.9	19.4
60	22.0	1.5	3.5	174.9	12.61	131.9	99.2	4.07	180.2	124.3	0.69	11.56	219.6	15.6
	34.0	2.7	6.2	177.8	12.78	134.2	99.7	4.08	185.1	127.8	0.69	11.10	223.0	16.7
	45.0	3.8	8.8	180.4	12.93	136.2	100.1	4.09	189.7	130.9	0.69	10.68	226.1	17.8
70	22.0	1.4	3.2	192.7	13.03	148.3	102.3	4.34	177.0	123.9	0.70	12.35	219.1	14.3
	34.0	2.6	6.0	195.8	13.20	150.8	102.9	4.35	181.8	127.4	0.70	11.85	222.3	15.3
	45.0	3.6	8.3	198.7	13.36	153.1	103.4	4.36	186.3	130.6	0.70	11.40	225.2	16.3
80	22.0	1.3	3.0	210.5	13.38	164.8	105.5	4.61	173.1	118.7	0.69	13.32	218.6	13.0
	34.0	2.5	5.8	213.8	13.55	167.6	106.1	4.62	178.2	122.2	0.69	12.71	221.6	14.0
	45.0	3.5	8.1	217.0	13.72	170.2	106.6	4.64	182.3	125.0	0.69	12.30	224.2	14.8
90	22.0	1.2	2.8	228.2	13.73	181.4	108.6	4.87	169.3	113.4	0.67	14.30	218.1	11.8
	34.0	2.4	5.5	231.8	13.91	184.3	109.3	4.88	174.6	117.0	0.67	13.64	221.2	12.8
	45.0	3.3	7.6	235.3	14.08	187.3	109.9	4.90	178.2	119.5	0.67	13.20	223.2	13.5
100	22.0	1.1	2.5	Operation not recommended					Operation not recommended					
	34.0	2.3	5.3						171.1	115.5	0.68	14.93	222.1	11.5
	45.0	3.2	7.4						173.8	116.5	0.67	14.45	223.1	12.0
110	22.0	1.0	2.3	Operation not recommended					Operation not recommended					
	34.0	2.2	5.1						165.9	111.8	0.67	16.14	221.0	10.3
	45.0	3.1	7.2						169.3	113.5	0.67	15.70	222.9	10.8
120	22.0	0.9	2.1	Operation not recommended					Operation not recommended					
	34.0	2.1	4.9						161.4	110.8	0.69	17.82	222.2	9.1
	45.0	3.0	6.9						164.9	112.4	0.68	17.30	223.9	9.5

Interpolation is permissible, extrapolation is not.

3/30/21

All entering air conditions are 80°F DB and 67°F WB in Cooling and 70°F DB in Heating.

All performance data is based upon the lower voltage of dual voltage units.

Operation below 60°F EWT requires optional insulated water/refrigerant circuit.

Operation below 40°F EWT is based upon 15% antifreeze solution.

See performance correction tables for operating conditions other than those listed above.



Contractor: \_\_\_\_\_ P.O.: \_\_\_\_\_

Engineer: \_\_\_\_\_

Project Name: \_\_\_\_\_ Unit Tag: \_\_\_\_\_

## 240 - Part Load - Performance Data

### Capacity Data (5400 CFM)

EWT °F	WATER FLOW GPM	WPD		HEATING - EAT 70 °F					COOLING - EAT 80/67 °F					
		PSI	FT	HC	KW	HE	LAT	COP	TC	SC	S/T	KW	HR	EER
20	22.0	1.4	3.2	Operation not recommended					Operation not recommended					
	35.0	2.7	6.2											
	50.0	4.1	9.5	70.8	5.64	51.6	80.1	3.68						
30	22.0	1.4	3.2	Operation not recommended					Operation not recommended					
	35.0	2.7	6.2	80.8	6.12	59.9	81.8	3.86	154.2	107.3	0.70	5.13	171.7	30.0
	50.0	4.0	9.2	82.0	6.20	60.8	82.1	3.88	156.3	109.4	0.70	4.82	172.7	32.4
40	22.0	1.3	3.0	97.0	6.81	73.8	84.6	4.18	145.5	103.3	0.71	5.62	412.1	25.8
	35.0	2.6	6.0	98.5	6.90	75.0	84.9	4.19	150.1	106.4	0.71	5.47	168.8	27.4
	50.0	3.9	9.0	100.0	6.98	76.2	85.1	4.20	153.2	109.0	0.71	5.19	170.9	29.5
50	22.0	1.2	2.8	114.5	7.02	90.5	87.6	4.78	142.5	102.6	0.72	6.02	163.1	23.7
	35.0	2.5	5.8	116.1	7.10	91.9	87.9	4.79	146.0	105.4	0.72	5.81	165.8	25.1
	50.0	3.8	8.8	118.0	7.20	93.4	88.2	4.80	150.0	108.6	0.72	5.56	169.0	27.0
60	22.0	1.2	2.8	130.6	7.31	105.7	90.4	5.23	137.5	100.4	0.73	6.38	159.3	21.6
	35.0	2.5	5.8	132.5	7.40	107.2	90.7	5.25	140.9	103.1	0.73	6.15	161.9	22.9
	50.0	3.7	8.5	134.7	7.50	109.1	91.1	5.26	144.8	106.3	0.73	5.89	164.8	24.6
70	22.0	1.1	2.5	146.8	7.61	120.8	93.2	5.66	132.5	98.1	0.74	6.74	155.5	19.7
	35.0	2.4	5.5	148.9	7.70	122.6	93.5	5.67	135.8	100.8	0.74	6.50	157.9	20.9
	50.0	3.6	8.3	151.3	7.80	124.7	93.9	5.69	139.5	103.9	0.74	6.22	160.7	22.4
80	22.0	1.1	2.5	163.0	8.00	135.7	95.9	5.97	127.1	95.9	0.75	7.63	153.1	16.7
	35.0	2.3	5.3	165.4	8.10	137.8	96.4	5.98	130.6	98.7	0.76	7.27	155.4	18.0
	50.0	3.5	8.1	168.0	8.21	140.0	96.8	6.00	133.8	101.2	0.76	7.04	157.8	19.0
90	22.0	1.0	2.3	179.2	8.39	150.5	98.7	6.25	121.6	93.6	0.77	8.51	150.7	14.3
	35.0	2.2	5.1	181.9	8.51	152.9	99.2	6.27	125.4	96.6	0.77	8.12	153.2	15.4
	50.0	3.4	7.9	184.7	8.61	155.3	99.7	6.29	128.0	98.5	0.77	7.86	154.8	16.3
100	22.0	0.9	2.1	Operation not recommended					Operation not recommended					
	35.0	2.1	4.9						120.5	95.1	0.79	9.64	153.4	12.5
	50.0	3.3	7.6						122.4	95.9	0.78	9.33	154.2	13.1
110	22.0	0.8	1.8	Operation not recommended					Operation not recommended					
	35.0	2.0	4.6						114.4	91.8	0.80	11.10	152.2	10.3
	50.0	3.2	7.4						116.7	93.2	0.80	10.80	153.5	10.8
120	22.0	0.7	1.6	Operation not recommended					Operation not recommended					
	35.0	1.9	4.4						108.8	89.2	0.82	12.67	152.0	8.6
	50.0	3.1	7.2						111.1	90.5	0.81	12.30	153.1	9.0

Interpolation is permissible, extrapolation is not.

3/30/21

All entering air conditions are 80°F DB and 67°F WB in Cooling and 70°F DB in Heating.

All performance data is based upon the lower voltage of dual voltage units.

Operation below 60°F EWT requires optional insulated water/refrigerant circuit.

Operation below 40°F EWT is based upon 15% antifreeze solution.

See performance correction tables for operating conditions other than those listed above.



Contractor: \_\_\_\_\_ P.O.: \_\_\_\_\_

Engineer: \_\_\_\_\_

Project Name: \_\_\_\_\_ Unit Tag: \_\_\_\_\_

## 240 - Full Load - Performance Data

### Capacity Data (7500 CFM)

EWT °F	WATER FLOW GPM	WPD		HEATING - EAT 70 °F					COOLING - EAT 80/67 °F					
		PSI	FT	HC	KW	HE	LAT	COP	TC	SC	S/T	KW	HR	EER
20	35.0	1.8	4.2	Operation not recommended					Operation not recommended					
	50.0	3.0	6.9											
	60.0	6.1	14.1	164.7	14.21	116.2	88.3	3.40						
30	35.0	1.8	4.2	Operation not recommended					Operation not recommended					
	50.0	3.0	6.9	176.8	13.60	130.4	89.8	3.81	299.6	217.5	0.73	10.39	335.1	28.8
	60.0	6.0	13.9	185.8	14.60	136.0	90.9	3.73	303.7	221.7	0.73	9.76	337.0	31.1
40	35.0	1.7	3.9	200.7	14.53	151.1	92.8	4.05	280.3	207.5	0.74	11.22	412.1	25.8
	50.0	2.9	6.7	199.8	14.31	151.0	92.7	4.09	289.5	213.3	0.74	10.90	326.7	26.6
	60.0	5.9	13.6	206.9	14.90	156.1	93.5	4.07	295.1	218.1	0.74	10.36	330.4	28.5
50	35.0	1.6	3.7	221.2	14.82	170.6	95.3	4.37	272.2	204.0	0.75	11.86	312.6	22.9
	50.0	2.8	6.5	225.3	15.05	173.9	95.8	4.39	279.3	209.2	0.75	11.41	318.3	24.5
	60.0	5.8	13.4	228.0	15.20	176.1	96.1	4.40	286.5	214.4	0.75	10.95	323.9	26.2
60	35.0	1.6	3.7	251.9	15.61	198.6	99.1	4.73	260.0	198.7	0.76	12.90	304.0	20.2
	50.0	2.7	6.2	256.5	15.85	202.4	99.7	4.74	266.9	204.1	0.76	12.40	309.2	21.5
	60.0	5.7	13.2	259.7	16.02	205.0	100.1	4.75	273.7	209.5	0.77	11.91	314.3	23.0
70	35.0	1.5	3.5	282.6	16.41	226.6	102.9	5.05	247.9	193.3	0.78	13.93	295.4	17.8
	50.0	2.6	6.0	287.8	16.66	231.0	103.5	5.06	254.4	199.0	0.78	13.40	300.1	19.0
	60.0	5.6	12.9	291.3	16.83	233.9	104.0	5.07	260.9	204.6	0.78	12.86	304.8	20.3
80	35.0	1.5	3.5	313.3	17.05	255.1	106.7	5.39	236.7	189.2	0.80	15.42	289.3	15.4
	50.0	2.5	5.8	318.6	17.29	259.6	107.3	5.40	243.6	195.0	0.80	14.70	293.7	16.6
	60.0	5.4	12.5	323.0	17.49	263.3	107.9	5.41	249.2	199.2	0.80	14.23	297.8	17.5
90	35.0	1.4	3.2	344.1	17.69	283.7	110.5	5.70	225.6	185.0	0.82	16.90	283.3	13.4
	50.0	2.4	5.5	349.4	17.92	288.2	111.1	5.71	232.8	191.0	0.82	16.12	287.7	14.4
	60.0	5.3	12.2	354.7	18.14	292.8	111.8	5.73	237.5	193.7	0.82	15.60	290.7	15.2
100	35.0	1.3	3.0	Operation not recommended					Operation not recommended					
	50.0	2.3	5.3						219.4	186.3	0.85	18.65	283.0	11.8
	60.0	5.2	12.0						222.8	187.9	0.84	18.05	284.3	12.3
110	35.0	1.2	2.8	Operation not recommended					Operation not recommended					
	50.0	2.2	5.1						203.8	179.4	0.88	21.07	275.7	9.7
	60.0	5.1	11.8						208.0	182.1	0.88	20.50	277.9	10.1
120	35.0	1.1	2.5	Operation not recommended					Operation not recommended					
	50.0	2.1	4.9						190.6	173.8	0.91	25.03	276.0	7.6
	60.0	5.0	11.6						194.7	176.4	0.91	24.30	277.6	8.0

Interpolation is permissible, extrapolation is not.

3/30/21

All entering air conditions are 80°F DB and 67°F WB in Cooling and 70°F DB in Heating.

All performance data is based upon the lower voltage of dual voltage units.

Operation below 60°F EWT requires optional insulated water/refrigerant circuit.

Operation below 40°F EWT is based upon 15% antifreeze solution.

See performance correction tables for operating conditions other than those listed above.

Contractor: \_\_\_\_\_ P.O.: \_\_\_\_\_

Engineer: \_\_\_\_\_

Project Name: \_\_\_\_\_ Unit Tag: \_\_\_\_\_

**Affinity YDL Series**  
**Single Capacity**  
**7 - 30 Tons 60Hz**



## 300 - Part Load - Performance Data

### Capacity Data (6000 CFM)

EWT °F	WATER FLOW GPM	WPD		HEATING - EAT 70 °F					COOLING - EAT 80/67 °F					
		PSI	FT	HC	KW	HE	LAT	COP	TC	SC	S/T	KW	HR	EER
20	20.0	1.1	2.5	Operation not recommended					Operation not recommended					
	37.0	2.9	6.7											
	50.0	4.3	9.9	81.0	6.58	58.5	79.5	3.61						
30	20.0	1.0	2.3	Operation not recommended										
	37.0	2.8	6.5	84.2	6.64	61.6	80.0	3.72	200.2	145.3	0.73	5.3	218.1	38.0
	50.0	4.2	9.7	85.5	6.72	62.6	80.2	3.73	202.9	148.1	0.73	5.0	219.8	41.0
40	20.0	0.9	2.1	111.8	8.21	83.8	83.9	3.99	184.0	136.2	0.74	6.02	204.5	30.6
	37.0	2.7	6.2	113.5	8.32	85.1	84.2	4.00	190.3	140.3	0.74	5.83	210.2	32.7
	50.0	4.1	9.5	115.3	8.42	86.5	84.4	4.01	193.7	143.3	0.74	5.56	212.7	34.9
50	20.0	0.8	1.8	140.7	9.20	109.2	88.0	4.48	175.3	131.5	0.75	6.67	198.0	26.3
	37.0	2.6	6.0	143.1	9.34	111.3	88.4	4.49	180.5	135.4	0.75	6.38	202.3	28.3
	50.0	4.0	9.2	145.0	9.44	112.8	88.7	4.50	184.5	138.4	0.75	6.16	205.5	30.0
60	20.0	0.7	1.6	156.8	9.63	123.9	90.3	4.77	162.1	132.0	0.81	8.07	189.6	20.1
	37.0	2.5	5.8	159.5	9.77	126.2	90.7	4.78	166.9	136.1	0.82	7.72	193.2	21.6
	50.0	3.8	8.8	161.7	9.88	127.9	91.0	4.80	170.6	139.2	0.82	7.45	196.0	22.9
70	20.0	0.6	1.4	173.0	10.06	138.6	92.6	5.04	148.9	132.5	0.89	9.47	181.2	15.7
	37.0	2.4	5.4	176.0	10.21	141.2	93.1	5.05	153.3	136.8	0.89	9.06	184.2	16.9
	50.0	3.6	8.4	178.3	10.32	143.1	93.4	5.06	156.7	140.0	0.89	8.74	186.5	17.9
80	20.0	0.5	1.2	189.0	10.37	153.6	94.9	5.34	144.9	118.4	0.82	9.51	177.3	15.2
	37.0	2.3	5.3	192.1	10.51	156.2	95.4	5.35	149.3	122.5	0.82	9.07	180.3	16.5
	50.0	3.5	8.1	194.8	10.64	158.5	95.7	5.37	152.5	125.2	0.82	8.78	182.4	17.4
90	20.0	0.4	0.9	205.0	10.68	168.5	97.2	5.63	140.9	104.4	0.74	9.54	173.4	14.8
	37.0	2.2	5.1	208.1	10.82	171.2	97.6	5.64	145.3	108.2	0.74	9.10	176.4	16.0
	50.0	3.4	7.9	211.3	10.95	173.9	98.1	5.66	148.3	110.3	0.74	8.81	178.4	16.8
100	20.0	0.3	0.7	Operation not recommended					Operation not recommended					
	37.0	2.1	4.9						141.9	106.6	0.75	9.16	173.1	15.5
	50.0	3.3	7.6						144.1	107.5	0.75	8.87	174.3	16.2
110	20.0	0.2	0.5	Operation not recommended					Operation not recommended					
	37.0	2.0	4.6						137.0	103.2	0.75	9.17	168.3	14.9
	50.0	3.2	7.4						139.8	104.7	0.75	8.92	170.2	15.7
120	20.0	0.1	0.2	Operation not recommended					Operation not recommended					
	37.0	1.9	4.4						132.8	101.9	0.77	9.26	164.3	14.3
	50.0	3.1	7.2						135.6	103.4	0.76	8.99	166.3	15.1

Interpolation is permissible, extrapolation is not.

3/30/21

All entering air conditions are 80°F DB and 67°F WB in Cooling and 70°F DB in Heating.

All performance data is based upon the lower voltage of dual voltage units.

Operation below 60°F EWT requires optional insulated water/refrigerant circuit.

Operation below 40°F EWT is based upon 15% antifreeze solution.

See performance correction tables for operating conditions other than those listed above.

Contractor: \_\_\_\_\_ P.O.: \_\_\_\_\_

Engineer: \_\_\_\_\_

Project Name: \_\_\_\_\_ Unit Tag: \_\_\_\_\_

**Affinity YDL Series**  
**Single Capacity**  
**7 - 30 Tons 60Hz**



## 300 - Full Load - Performance Data

### Capacity Data (9000 CFM)

EWT °F	WATER FLOW GPM	WPD		HEATING - EAT 70 °F					COOLING - EAT 80/67 °F											
		PSI	FT	HC	KW	HE	LAT	COP	TC	SC	S/T	KW	HR	EER						
20	35.0	2.9	6.7	Operation not recommended					Operation not recommended											
	50.0	4.3	9.9																	
	75.0	7.7	17.8	191.0	17.00	133.0	87.7	3.29												
30	35.0	2.8	6.5	Operation not recommended																
	50.0	4.2	9.7	222.6	17.68	162.3	90.9	3.69							361.3	244.3	0.7	12.7	404.6	28.4
	75.0	7.6	17.6	226.0	17.90	164.9	91.3	3.70							366.2	249.0	0.7	11.9	406.9	30.7
40	35.0	2.7	6.2	238.2	18.77	174.1	92.5	3.72	342.8	236.5	0.69	13.91	412.1	25.8						
	50.0	4.1	9.5	255.2	20.64	184.8	94.3	3.62	352.0	241.9	0.69	13.64	398.6	25.8						
	75.0	7.5	17.3	258.0	19.30	192.2	94.5	3.92	360.9	248.2	0.69	12.85	404.7	28.1						
50	35.0	2.6	6.0	281.3	20.17	212.5	96.9	4.09	337.7	236.4	0.70	14.90	388.5	22.7						
	50.0	4.0	9.2	283.8	20.32	214.5	97.2	4.09	342.8	239.6	0.70	14.57	392.5	23.5						
	75.0	7.3	16.9	290.0	20.69	219.4	97.8	4.11	355.5	247.6	0.70	13.75	402.4	25.9						
60	35.0	2.5	5.8	315.3	19.87	247.5	100.4	4.65	323.5	234.2	0.72	16.49	379.7	19.6						
	50.0	3.9	9.0	318.0	20.01	249.8	100.7	4.66	328.3	237.5	0.72	16.13	383.4	20.4						
	75.0	7.2	16.6	325.0	20.38	255.5	101.4	4.67	340.5	245.9	0.72	15.23	392.4	22.4						
70	35.0	2.4	5.5	349.2	19.56	282.5	103.9	5.23	309.2	231.9	0.75	18.09	371.0	17.1						
	50.0	3.8	8.8	352.3	19.70	285.1	104.2	5.24	313.9	235.4	0.75	17.69	374.2	17.7						
	75.0	7.0	16.1	360.0	20.06	291.6	105.0	5.26	325.5	244.2	0.75	16.70	382.5	19.5						
80	35.0	2.3	5.3	390.9	20.40	321.3	108.2	5.62	293.9	228.1	0.78	20.33	363.3	14.5						
	50.0	3.7	8.5	395.8	20.61	325.5	108.7	5.63	300.7	233.3	0.78	19.40	366.8	15.5						
	75.0	6.8	15.7	403.0	20.92	331.6	109.5	5.65	309.4	240.0	0.78	18.77	373.4	16.5						
90	35.0	2.2	5.1	432.6	21.24	360.2	112.5	5.97	278.6	224.3	0.80	22.58	355.7	12.3						
	50.0	3.6	8.3	439.3	21.52	365.9	113.2	5.98	287.4	231.1	0.80	21.53	360.9	13.3						
	75.0	6.4	14.8	446.0	21.78	371.7	113.9	6.00	293.3	235.9	0.80	20.84	364.4	14.1						
100	35.0	2.1	4.9	Operation not recommended					Operation not recommended											
	50.0	3.5	8.1						284.7	237.0	0.83	25.34	371.2	11.2						
	75.0	6.2	14.3						289.1	239.0	0.83	24.52	372.7	11.8						
110	35.0	2.0	4.6	Operation not recommended					Operation not recommended											
	50.0	3.4	7.9						279.1	238.5	0.85	28.99	378.0	9.6						
	75.0	6.0	13.8						284.8	242.1	0.85	28.20	381.0	10.1						
120	35.0	1.9	4.4	Operation not recommended					Operation not recommended											
	50.0	3.3	7.6						258.1	223.4	0.87	30.08	360.7	8.6						
	75.0	5.8	13.4						263.6	226.7	0.86	29.20	363.2	9.0						

Interpolation is permissible, extrapolation is not.

3/30/21

All entering air conditions are 80°F DB and 67°F WB in Cooling and 70°F DB in Heating.

All performance data is based upon the lower voltage of dual voltage units.

Operation below 60°F EWT requires optional insulated water/refrigerant circuit.

Operation below 40°F EWT is based upon 15% antifreeze solution.

See performance correction tables for operating conditions other than those listed above.

\* System Design Not Recommended



Contractor: \_\_\_\_\_ P.O.: \_\_\_\_\_

Engineer: \_\_\_\_\_

Project Name: \_\_\_\_\_ Unit Tag: \_\_\_\_\_

## 360 - Part Load - Performance Data

### Capacity Data (7500 CFM)

EWT °F	WATER FLOW GPM	WPD		HEATING - EAT 70 °F					COOLING - EAT 80/67 °F					
		PSI	FT	HC	KW	HE	LAT	COP	TC	SC	S/T	KW	HR	EER
20	25.0	1.6	3.7	Operation not recommended					Operation not recommended					
	35.0	2.4	5.5											
	45.0	3.1	7.2	82.0	7.54	56.3	78.1	3.19						
30	25.0	1.5	3.5	Operation not recommended					Operation not recommended					
	35.0	2.3	5.3	95.1	8.33	66.6	79.7	3.35	215.6	128.7	0.60	9.65	248.6	22.3
	45.0	3.0	6.9	98.0	8.54	68.9	80.1	3.36	218.6	131.2	0.60	9.06	249.5	24.1
40	25.0	1.4	3.2	130.0	10.24	95.0	84.0	3.72	198.8	119.3	0.60	10.24	233.8	19.4
	35.0	2.2	5.1	132.0	10.37	96.6	84.3	3.73	205.3	123.6	0.60	9.95	239.3	20.6
	45.0	2.9	6.7	134.0	10.50	98.2	84.5	3.74	209.3	126.2	0.60	9.46	241.6	22.1
50	25.0	1.3	3.0	164.9	12.15	123.4	88.4	3.98	190.0	115.9	0.61	10.67	226.4	17.8
	35.0	2.1	4.9	167.5	12.30	125.5	88.7	3.99	195.0	118.6	0.61	10.26	230.0	19.0
	45.0	2.8	6.5	170.0	12.46	127.5	89.0	4.00	200.0	121.2	0.61	9.85	233.6	20.3
60	25.0	1.2	2.8	192.9	13.79	145.9	91.8	4.10	179.4	115.4	0.64	11.33	218.1	15.8
	35.0	2.0	4.6	195.9	13.96	148.3	92.2	4.11	184.2	118.2	0.64	10.89	221.3	16.9
	45.0	2.7	6.2	198.9	14.14	150.7	92.6	4.12	188.9	121.0	0.64	10.46	224.6	18.1
70	25.0	1.1	2.5	221.0	15.42	168.3	95.3	4.20	168.9	114.8	0.68	11.98	209.8	14.1
	35.0	1.9	4.4	224.4	15.62	171.1	95.7	4.21	173.3	117.8	0.68	11.52	212.6	15.0
	45.0	2.6	6.0	227.8	15.82	173.8	96.1	4.22	177.8	120.9	0.68	11.06	215.5	16.1
80	25.0	1.0	2.3	249.0	16.88	191.4	98.7	4.32	167.1	111.9	0.67	14.17	215.4	11.8
	35.0	1.8	4.2	252.8	17.10	194.5	99.2	4.33	171.9	115.2	0.67	13.52	218.0	12.7
	45.0	2.5	5.8	256.7	17.31	197.6	99.7	4.35	175.9	118.1	0.67	13.08	220.5	13.4
90	25.0	0.9	2.1	277.0	18.33	214.5	102.2	4.43	165.3	109.0	0.66	16.36	221.1	10.1
	35.0	1.7	3.9	281.3	18.57	217.9	102.7	4.44	170.5	112.5	0.66	15.60	223.8	10.9
	45.0	2.4	5.5	285.6	18.80	221.5	103.3	4.45	174.0	115.3	0.66	15.10	225.5	11.5
100	25.0	0.8	1.8	Operation not recommended					Operation not recommended					
	35.0	1.6	3.7						168.6	115.5	0.69	17.54	228.4	9.6
	45.0	2.3	5.3						171.2	116.5	0.68	16.98	229.1	10.1
110	25.0	0.7	1.6	Operation not recommended					Operation not recommended					
	35.0	1.5	3.5						165.0	115.9	0.70	19.38	231.1	8.5
	45.0	2.2	5.1						168.3	117.7	0.70	18.85	232.6	8.9
120	25.0	0.6	1.4	Operation not recommended					Operation not recommended					
	35.0	1.4	3.2						162.1	110.2	0.68	21.12	234.1	7.7
	45.0	2.1	4.9						165.6	111.8	0.68	20.50	235.5	8.1

Interpolation is permissible, extrapolation is not.

3/30/21

All entering air conditions are 80°F DB and 67°F WB in Cooling and 70°F DB in Heating.

All performance data is based upon the lower voltage of dual voltage units.

Operation below 60°F EWT requires optional insulated water/refrigerant circuit.

Operation below 40°F EWT is based upon 15% antifreeze solution.

See performance correction tables for operating conditions other than those listed above.



Contractor: \_\_\_\_\_ P.O.: \_\_\_\_\_

Engineer: \_\_\_\_\_

Project Name: \_\_\_\_\_ Unit Tag: \_\_\_\_\_

## 360 - Full Load - Performance Data

### Capacity Data (9900 CFM)

EWT °F	WATER FLOW GPM	WPD		HEATING - EAT 70 °F					COOLING - EAT 80/67 °F					
		PSI	FT	HC	KW	HE	LAT	COP	TC	SC	S/T	KW	HR	EER
20	50.0	3.5	8.1	Operation not recommended					Operation not recommended					
	70.0	6.2	14.3											
	90.0	8.8	20.3	223.3	22.00	148.2	88.9	2.97						
30	50.0	3.4	7.9	Operation not recommended					Operation not recommended					
	70.0	6.1	14.1	258.3	23.46	178.2	92.2	3.23	457.5	295.7	0.65	23.96	539.3	19.1
	90.0	8.7	20.1	262.2	23.75	181.2	92.5	3.24	463.8	301.5	0.65	22.50	540.6	20.6
40	50.0	3.3	7.6	292.1	24.35	209.0	95.3	3.52	421.0	273.6	0.65	24.70	505.3	17.0
	70.0	6.0	13.9	296.6	24.67	212.4	95.7	3.52	435.3	284.2	0.65	23.96	517.1	18.2
	90.0	8.6	19.9	301.1	24.98	215.9	96.2	3.53	443.2	290.2	0.65	22.80	520.9	19.4
50	50.0	3.2	7.4	329.8	25.55	242.6	98.8	3.78	401.4	264.9	0.66	25.02	486.8	16.0
	70.0	5.9	13.6	335.5	25.91	247.1	99.4	3.79	413.1	272.7	0.66	23.96	494.8	17.2
	90.0	8.5	19.6	340.0	26.20	250.6	99.8	3.80	422.5	278.9	0.66	23.10	501.3	18.3
60	50.0	3.1	7.2	362.1	27.22	269.3	101.9	3.90	371.2	253.5	0.68	25.08	456.7	14.8
	70.0	5.8	13.4	368.4	27.61	274.2	102.5	3.91	382.0	260.6	0.68	24.01	463.9	15.9
	90.0	8.4	19.4	373.3	27.92	278.1	102.9	3.92	390.7	266.2	0.68	23.15	469.7	16.9
70	50.0	3.0	6.9	394.5	28.90	295.9	104.9	4.00	340.9	242.1	0.71	25.13	426.7	13.6
	70.0	5.7	13.2	401.2	29.31	301.2	105.5	4.01	350.9	248.5	0.71	24.06	433.0	14.6
	90.0	8.3	19.2	406.7	29.64	305.5	106.0	4.02	358.9	253.6	0.71	23.20	438.0	15.5
80	50.0	2.9	6.7	426.8	30.44	322.9	107.9	4.11	335.7	233.4	0.70	29.30	435.7	11.5
	70.0	5.6	12.9	433.7	30.86	328.4	108.6	4.12	345.9	240.2	0.69	27.95	441.2	12.4
	90.0	8.2	18.9	440.0	31.22	333.5	109.2	4.13	353.3	244.6	0.69	27.05	445.6	13.1
90	50.0	2.8	6.5	459.1	31.98	350.0	110.9	4.21	330.4	224.7	0.68	33.47	444.6	9.9
	70.0	5.5	12.7	466.2	32.40	355.6	111.6	4.22	340.8	231.8	0.68	31.93	449.8	10.7
	90.0	8.1	18.7	473.3	32.80	361.4	112.3	4.23	347.8	235.5	0.68	30.90	453.2	11.3
100	50.0	2.7	6.2	Operation not recommended					Operation not recommended					
	70.0	5.4	12.5						337.1	224.4	0.67	36.25	460.8	9.3
	90.0	8.0	18.5						342.2	226.3	0.66	35.09	461.9	9.8
110	50.0	2.6	6.0	Operation not recommended					Operation not recommended					
	70.0	5.3	12.2						329.9	213.9	0.65	40.37	467.7	8.2
	90.0	7.9	18.2						336.7	217.0	0.64	39.27	470.7	8.6
120	50.0	2.5	5.8	Operation not recommended					Operation not recommended					
	70.0	5.2	12.0						324.2	204.4	0.63	46.04	481.2	7.0
	90.0	7.8	18.0						331.1	207.5	0.63	44.70	483.6	7.4

Interpolation is permissible, extrapolation is not.

3/30/21

All entering air conditions are 80°F DB and 67°F WB in Cooling and 70°F DB in Heating.

All performance data is based upon the lower voltage of dual voltage units.

Operation below 60°F EWT requires optional insulated water/refrigerant circuit.

Operation below 40°F EWT is based upon 15% antifreeze solution.

See performance correction tables for operating conditions other than those listed above.





Contractor: \_\_\_\_\_ P.O.: \_\_\_\_\_

Engineer: \_\_\_\_\_

Project Name: \_\_\_\_\_ Unit Tag: \_\_\_\_\_

## 084 - Part Load Horizontal - Performance Data

### Capacity Data (1700 CFM)

EWT °F	WATER FLOW GPM	WPD		HEATING - EAT 70 °F					COOLING - EAT 80/67 °F					
		PSI	FT	HC	KW	HE	LAT	COP	TC	SC	S/T	KW	HR	EER
20	8.0	1.6	3.7	Operation not recommended					Operation not recommended					
	10.0	1.8	4.2											
	16.0	3.6	8.3	37.8	3.3	26.5	88.0	3.34						
30	8.0	1.5	3.5	Operation not recommended					Operation not recommended					
	10.0	1.7	3.9	40.3	3.47	28.4	89.3	3.40	71.6	42.7	0.60	2.03	78.6	35.2
	16.0	3.5	8.1	41.5	3.56	29.4	90.0	3.42	72.6	43.6	0.60	1.91	79.1	38.0
40	8.0	1.4	3.2	46.3	3.49	34.4	92.5	3.89	66.7	40.0	0.60	2.13	74.0	31.4
	10.0	1.6	3.7	47.8	3.48	35.9	93.3	4.03	68.5	41.3	0.60	2.09	75.6	32.8
	16.0	3.4	7.9	47.8	3.58	35.5	93.3	3.91	70.3	42.5	0.60	1.97	77.0	35.8
50	8.0	1.3	3.0	52.4	3.51	40.4	95.7	4.38	64.5	39.3	0.61	2.19	72.0	29.5
	10.0	1.5	3.5	52.8	3.53	40.7	95.9	4.39	65.4	39.8	0.61	2.15	72.7	30.5
	16.0	3.3	7.6	54.0	3.60	41.7	96.6	4.40	67.9	41.4	0.61	2.02	74.8	33.6
60	8.0	1.2	2.8	58.2	3.55	46.1	98.8	4.80	61.4	38.3	0.62	2.58	70.2	23.8
	10.0	1.4	3.2	58.7	3.57	46.5	99.0	4.81	62.2	38.8	0.62	2.53	70.9	24.6
	16.0	3.2	7.4	60.0	3.64	47.6	99.7	4.83	64.7	40.4	0.62	2.38	72.8	27.2
70	8.0	1.1	2.5	64.0	3.60	51.7	101.9	5.22	58.3	37.3	0.64	2.97	68.5	19.7
	10.0	1.3	3.0	64.5	3.62	52.2	102.1	5.22	59.1	37.8	0.64	2.91	69.0	20.3
	16.0	3.1	7.2	66.0	3.69	53.4	102.9	5.24	61.4	39.3	0.64	2.74	70.7	22.4
80	8.0	1.0	2.3	68.9	3.66	56.4	104.5	5.52	55.3	36.2	0.65	3.56	67.4	15.5
	10.0	1.2	2.8	69.7	3.70	57.1	104.9	5.53	56.5	37.0	0.65	3.39	68.1	16.6
	16.0	3.0	6.9	71.1	3.76	58.2	105.6	5.55	58.2	38.1	0.65	3.29	69.4	17.7
90	8.0	0.9	2.1	73.8	3.72	61.1	107.1	5.81	52.3	35.0	0.67	4.15	66.4	12.6
	10.0	1.0	2.3	75.0	3.77	62.1	107.7	5.82	53.9	36.1	0.67	3.96	67.4	13.6
	16.0	2.9	6.7	76.1	3.82	63.1	108.3	5.84	55.0	36.9	0.67	3.83	68.1	14.4
100	8.0	0.8	1.8	Operation not recommended					Operation not recommended					
	10.0	0.9	2.1						51.0	33.5	0.66	4.23	65.4	12.0
	16.0	2.8	6.5						51.8	33.8	0.65	4.10	65.7	12.6
110	8.0	0.7	1.6	Operation not recommended					Operation not recommended					
	10.0	0.8	1.8						47.5	30.2	0.63	4.48	62.8	10.6
	16.0	2.7	6.2						48.5	30.6	0.63	4.36	63.4	11.1
120	8.0	0.6	0.0	Operation not recommended					Operation not recommended					
	10.0	0.7	1.6						43.0	27.3	0.64	4.43	58.1	9.7
	16.0	2.6	6.0						43.9	27.7	0.63	4.30	58.6	10.2

Interpolation is permissible, extrapolation is not.

3/30/21

All entering air conditions are 80°F DB and 67°F WB in Cooling and 70°F DB in Heating.

All performance data is based upon the lower voltage of dual voltage units.

Operation below 60°F EWT requires optional insulated water/refrigerant circuit.

Operation below 40°F EWT is based upon 15% antifreeze solution.

See performance correction tables for operating conditions other than those listed above.

Contractor: \_\_\_\_\_ P.O.: \_\_\_\_\_

Engineer: \_\_\_\_\_

Project Name: \_\_\_\_\_ Unit Tag: \_\_\_\_\_

**Affinity YDL Series**  
**Single Capacity**  
**7 - 30 Tons 60Hz**



## 084 - Full Load Horizontal - Performance Data

### Capacity Data (2500 CFM)

EWT °F	WATER FLOW GPM	WPD		HEATING - EAT 70 °F					COOLING - EAT 80/67 °F					
		PSI	FT	HC	KW	HE	LAT	COP	TC	SC	S/T	KW	HR	EER
20	10.0	1.8	4.2	Operation not recommended					Operation not recommended					
	16.0	3.6	8.3											
	22.0	7.8	18.0	54.0	5.1	36.8	88.0	3.13						
30	10.0	1.7	3.9	Operation not recommended					Operation not recommended					
	16.0	3.5	8.1	62.3	5.20	44.5	91.1	3.51	91.8	64.8	0.71	3.64	104.3	25.2
	22.0	7.1	16.3	63.2	5.26	45.3	91.4	3.52	93.1	66.1	0.71	3.42	104.8	27.2
40	10.0	1.6	3.7	70.7	5.30	52.6	94.2	3.90	91.0	61.5	0.68	4.08	104.9	22.3
	16.0	3.4	7.9	73.0	5.30	54.9	95.0	4.04	93.9	63.5	0.68	3.90	107.2	24.1
	22.0	6.5	15.0	72.9	5.44	54.3	95.0	3.92	95.8	65.4	0.68	3.77	108.7	25.4
50	10.0	1.5	3.5	80.0	5.48	61.3	97.6	4.28	93.6	61.8	0.66	4.46	108.8	21.0
	16.0	3.3	7.6	81.3	5.55	62.3	98.1	4.29	96.0	63.4	0.66	4.29	110.7	22.4
	22.0	6.0	14.0	82.5	5.62	63.3	98.6	4.30	98.5	65.0	0.66	4.12	112.6	23.9
60	10.0	1.4	3.2	89.8	5.90	69.6	101.2	4.46	90.1	60.3	0.67	4.79	106.4	18.8
	16.0	3.2	7.4	91.2	5.97	70.8	101.8	4.47	92.4	61.9	0.67	4.60	108.1	20.1
	22.0	5.7	13.2	92.6	6.05	71.9	102.3	4.48	94.8	63.5	0.67	4.42	109.9	21.4
70	10.0	1.3	3.0	99.5	6.32	78.0	104.9	4.62	86.5	58.9	0.68	5.11	104.0	16.9
	16.0	3.1	7.2	101.1	6.40	79.2	105.4	4.63	88.8	60.4	0.68	4.92	105.6	18.1
	22.0	5.3	12.3	102.6	6.48	80.5	106.0	4.64	91.1	61.9	0.68	4.72	107.2	19.3
80	10.0	1.2	2.8	109.9	6.43	88.0	108.7	5.01	83.0	56.9	0.68	5.74	102.6	14.5
	16.0	3.0	6.9	111.6	6.51	89.4	109.3	5.02	85.4	58.5	0.68	5.47	104.1	15.6
	22.0	5.1	11.8	113.3	6.60	90.8	110.0	5.04	87.4	59.9	0.68	5.30	105.5	16.5
90	10.0	1.0	2.3	120.3	6.54	98.0	112.5	5.39	79.5	54.9	0.69	6.36	101.2	12.5
	16.0	2.9	6.7	122.1	6.63	99.5	113.2	5.40	82.0	56.6	0.69	6.07	102.7	13.5
	22.0	4.9	11.4	124.0	6.71	101.1	113.9	5.42	83.7	57.8	0.69	5.87	103.7	14.3
100	10.0	0.9	2.1	Operation not recommended					Operation not recommended					
	16.0	2.8	6.5						77.2	52.9	0.69	6.96	101.0	11.1
	22.0	4.8	11.1						78.4	53.4	0.68	6.74	101.4	11.6
110	10.0	0.8	1.8	Operation not recommended					Operation not recommended					
	16.0	2.7	6.2						71.6	49.9	0.70	7.82	98.3	9.2
	22.0	4.7	10.7						73.1	50.7	0.69	7.61	99.0	9.6
120	10.0	0.7	1.6	Operation not recommended					Operation not recommended					
	16.0	2.6	6.0						67.4	47.7	0.71	8.86	97.6	7.6
	22.0	4.5	10.4						68.8	48.4	0.70	8.60	98.1	8.0

Interpolation is permissible, extrapolation is not.  
 All entering air conditions are 80°F DB and 67°F WB in Cooling and 70°F DB in Heating.  
 All performance data is based upon the lower voltage of dual voltage units.  
 Operation below 60°F EWT requires optional insulated water/refrigerant circuit.  
 Operation below 40°F EWT is based upon 15% antifreeze solution.  
 See performance correction tables for operating conditions other than those listed above.

3/30/21

The manufacturer works continually to improve its products. As a result, the design and specifications of each product at the time of order may be changed without notice. Purchaser's approval of this data set signifies that the equipment is acceptable under the provisions of the job specification. Statements and other information contained herein are not express warranties and do not form the basis of any bargain between the parties, but are merely the manufacturer's opinion or commendation of its products. York and Affinity are registered trademarks of Johnson Controls, Inc., and are used with permission.



Contractor: \_\_\_\_\_ P.O.: \_\_\_\_\_

Engineer: \_\_\_\_\_

Project Name: \_\_\_\_\_ Unit Tag: \_\_\_\_\_

## 096 - Part Load Horizontal - Performance Data

### Capacity Data (1900 CFM)

EWT °F	WATER FLOW GPM	WPD		HEATING - EAT 70 °F					COOLING - EAT 80/67 °F					
		PSI	FT	HC	KW	HE	LAT	COP	TC	SC	S/T	KW	HR	EER
20	12.0	1.5	3.5	Operation not recommended					Operation not recommended					
	16.0	2.4	5.5											
	18.0	2.9	6.7	35.6	3.8	22.5	85.3	2.7						
30	12.0	1.4	3.2	Operation not recommended					Operation not recommended					
	16.0	2.3	5.3	42.4	3.84	29.3	88.7	3.24	79.7	51.5	0.65	2.11	86.9	37.8
	18.0	2.8	6.5	43.1	3.89	29.8	89.0	3.25	80.8	52.5	0.65	1.98	87.6	40.8
40	12.0	1.3	3.0	50.0	3.89	36.7	92.4	3.77	74.2	49.0	0.66	2.40	82.4	30.9
	16.0	2.2	5.1	53.4	3.95	40.0	94.0	3.97	77.0	50.6	0.66	2.31	84.9	33.3
	18.0	2.7	6.2	51.5	3.99	37.9	93.1	3.79	78.2	51.6	0.66	2.22	85.7	35.3
50	12.0	1.2	2.8	58.2	3.99	44.6	96.4	4.28	71.7	48.1	0.67	2.65	80.8	27.0
	16.0	2.1	4.9	59.4	4.06	45.6	96.9	4.29	74.2	49.7	0.67	2.52	82.8	29.5
	18.0	2.6	6.0	60.0	4.09	46.0	97.2	4.30	75.5	50.6	0.67	2.45	83.9	30.8
60	12.0	1.1	2.5	65.2	4.10	51.2	99.8	4.66	67.7	46.3	0.68	2.97	77.8	22.8
	16.0	2.0	4.6	66.5	4.17	52.3	100.4	4.68	70.1	47.9	0.68	2.82	79.7	24.9
	18.0	2.5	5.8	67.2	4.21	52.9	100.7	4.68	71.3	48.7	0.68	2.74	80.6	26.0
70	12.0	1.0	2.3	72.2	4.21	57.8	103.2	5.02	63.7	44.6	0.70	3.28	74.8	19.4
	16.0	1.9	4.4	73.7	4.28	59.0	103.9	5.04	65.9	46.1	0.70	3.11	76.5	21.2
	18.0	2.4	5.5	74.4	4.32	59.7	104.3	5.05	67.0	46.9	0.70	3.03	77.3	22.1
80	12.0	0.9	2.1	80.0	4.35	65.2	107.0	5.39	61.1	42.8	0.70	3.91	74.5	15.7
	16.0	1.8	4.2	81.4	4.41	66.4	107.7	5.41	63.2	44.2	0.70	3.73	75.9	17.0
	18.0	2.3	5.3	82.5	4.46	67.2	108.2	5.42	64.4	45.0	0.70	3.61	76.7	17.9
90	12.0	0.8	1.8	87.8	4.49	72.5	110.8	5.74	58.6	41.0	0.70	4.53	74.1	12.9
	16.0	1.7	3.9	89.2	4.54	73.7	111.5	5.75	60.5	42.3	0.70	4.32	75.2	14.0
	18.0	2.2	5.1	90.5	4.60	74.8	112.1	5.77	61.7	43.2	0.70	4.18	76.0	14.8
100	12.0	0.7	1.6	Operation not recommended					Operation not recommended					
	16.0	1.6	3.7						57.5	40.8	0.71	4.75	73.7	12.1
	18.0	2.1	4.9						58.4	41.1	0.70	4.60	74.0	12.7
110	12.0	0.6	1.4	Operation not recommended					Operation not recommended					
	16.0	1.5	3.5						53.9	38.5	0.71	5.15	71.5	10.5
	18.0	2.0	4.6						55.0	39.1	0.71	5.01	72.1	11.0
120	12.0	0.5	1.2	Operation not recommended					Operation not recommended					
	16.0	1.4	3.2						50.6	37.2	0.73	5.89	70.7	8.6
	18.0	1.9	4.4						51.7	37.7	0.73	5.72	71.2	9.0

Interpolation is permissible, extrapolation is not.

All entering air conditions are 80°F DB and 67°F WB in Cooling and 70°F DB in Heating.

All performance data is based upon the lower voltage of dual voltage units.

Operation below 60°F EWT requires optional insulated water/refrigerant circuit.

Operation below 40°F EWT is based upon 15% antifreeze solution.

See performance correction tables for operating conditions other than those listed above.

3/30/21

Contractor: \_\_\_\_\_ P.O.: \_\_\_\_\_

Engineer: \_\_\_\_\_

Project Name: \_\_\_\_\_ Unit Tag: \_\_\_\_\_

**Affinity YDL Series**  
**Single Capacity**  
**7 - 30 Tons 60Hz**



## 096 - Full Load Horizontal - Performance Data

### Capacity Data (2800 CFM)

EWT °F	WATER FLOW GPM	WPD		HEATING - EAT 70 °F					COOLING - EAT 80/67 °F					
		PSI	FT	HC	KW	HE	LAT	COP	TC	SC	S/T	KW	HR	EER
20	12.0	1.5	3.5	Operation not recommended					Operation not recommended					
	18.0	2.9	6.7											
	24.0	5.0	11.6	61.5	5.40	43.1	88.3	3.34						
30	12.0	1.4	3.2	Operation not recommended					Operation not recommended					
	18.0	2.8	6.5	70.5	5.73	51.0	91.3	3.61	101.4	70.6	0.70	4.23	115.8	24.0
	24.0	4.9	11.3	71.6	5.80	51.8	91.7	3.62	102.8	72.0	0.70	3.97	116.3	25.9
40	12.0	1.3	3.0	79.8	5.85	59.9	94.4	4.00	99.5	68.7	0.69	4.60	115.2	21.6
	18.0	2.7	6.2	81.2	5.72	61.7	94.8	4.16	102.7	70.1	0.68	4.47	118.0	23.0
	24.0	4.8	11.1	82.3	6.00	61.8	95.2	4.02	104.8	71.7	0.68	4.25	119.3	24.6
50	12.0	1.2	2.8	90.2	6.05	69.6	97.8	4.37	101.4	67.9	0.67	4.91	118.1	20.7
	18.0	2.6	6.0	91.6	6.12	70.7	98.3	4.39	104.0	69.7	0.67	4.72	120.1	22.0
	24.0	4.6	10.5	93.0	6.20	71.8	98.8	4.40	106.7	71.5	0.67	4.53	122.2	23.6
60	12.0	1.1	2.5	102.8	6.49	80.7	102.0	4.64	98.0	66.1	0.67	5.36	116.3	18.3
	18.0	2.5	5.8	104.4	6.58	82.0	102.5	4.65	100.6	67.9	0.67	5.15	118.1	19.5
	24.0	4.5	10.4	106.0	6.66	83.3	103.1	4.66	103.2	69.6	0.67	4.95	120.0	20.9
70	12.0	1.0	2.3	115.4	6.94	91.7	106.2	4.87	94.6	64.3	0.68	5.81	114.4	16.3
	18.0	2.4	5.5	117.2	7.03	93.2	106.8	4.89	97.1	66.0	0.68	5.58	116.2	17.4
	24.0	4.4	10.2	119.0	7.12	94.7	107.4	4.90	99.6	67.7	0.68	5.36	117.9	18.6
80	12.0	0.9	2.1	124.1	7.22	99.4	109.0	5.04	90.5	62.4	0.69	6.42	112.4	14.1
	18.0	2.3	5.3	126.0	7.31	101.0	109.7	5.05	93.1	64.2	0.69	6.13	114.0	15.2
	24.0	4.3	9.9	127.9	7.40	102.7	110.3	5.07	95.3	65.7	0.69	5.93	115.5	16.1
90	12.0	0.8	1.8	132.7	7.49	107.1	111.9	5.19	86.4	60.4	0.70	7.04	110.4	12.3
	18.0	2.2	5.1	134.7	7.59	108.9	112.6	5.21	89.1	62.4	0.70	6.72	112.0	13.3
	24.0	4.2	9.7	136.8	7.68	110.6	113.2	5.22	90.9	63.6	0.70	6.50	113.1	14.0
100	12.0	0.7	1.6	Operation not recommended					Operation not recommended					
	18.0	2.1	4.9						86.3	61.3	0.71	7.56	112.1	11.4
	24.0	4.1	9.5						87.7	61.8	0.70	7.32	112.6	12.0
110	12.0	0.6	1.4	Operation not recommended					Operation not recommended					
	18.0	2.0	4.6						82.7	59.0	0.71	8.37	111.3	9.9
	24.0	4.0	9.2						84.4	59.9	0.71	8.14	112.2	10.4
120	12.0	0.5	1.2	Operation not recommended					Operation not recommended					
	18.0	1.9	4.4						79.5	58.4	0.73	9.70	112.6	8.2
	24.0	3.9	9.0						81.2	59.3	0.73	9.42	113.3	8.6

Interpolation is permissible, extrapolation is not.

3/30/21

All entering air conditions are 80°F DB and 67°F WB in Cooling and 70°F DB in Heating.

All performance data is based upon the lower voltage of dual voltage units.

Operation below 60°F EWT requires optional insulated water/refrigerant circuit.

Operation below 40°F EWT is based upon 15% antifreeze solution.

See performance correction tables for operating conditions other than those listed above.

The manufacturer works continually to improve its products. As a result, the design and specifications of each product at the time of order may be changed without notice. Purchaser's approval of this data set signifies that the equipment is acceptable under the provisions of the job specification. Statements and other information contained herein are not express warranties and do not form the basis of any bargain between the parties, but are merely the manufacturer's opinion or commendation of its products. York and Affinity are registered trademarks of Johnson Controls, Inc., and are used with permission.



Contractor: \_\_\_\_\_ P.O.: \_\_\_\_\_

Engineer: \_\_\_\_\_

Project Name: \_\_\_\_\_ Unit Tag: \_\_\_\_\_

## 120 - Part Load Horizontal - Performance Data

### Capacity Data (2400 CFM)

EWT °F	WATER FLOW GPM	WPD		HEATING - EAT 70 °F					COOLING - EAT 80/67 °F					
		PSI	FT	HC	KW	HE	LAT	COP	TC	SC	S/T	KW	HR	EER
20	12.0	0.4	1.0	Operation not recommended					Operation not recommended					
	16.0	0.8	1.9											
	20.0	1.4	3.2	44.8	4.04	31.0	85.3	3.25						
30	12.0	0.4	1.0	Operation not recommended					Operation not recommended					
	16.0	0.8	1.8	52.6	4.06	38.7	88.3	3.80	94.1	58.0	0.62	3.34	105.5	28.1
	20.0	1.4	3.1	53.4	4.11	39.4	88.6	3.81	95.4	59.1	0.62	3.14	106.1	30.4
40	12.0	0.4	0.9	59.8	4.33	45.1	91.1	4.05	89.1	55.2	0.62	3.52	101.1	25.3
	16.0	0.8	1.8	60.8	4.39	45.8	91.4	4.06	92.0	57.3	0.62	3.42	103.6	26.9
	20.0	1.3	3.0	61.7	4.44	46.6	91.8	4.07	93.8	58.6	0.62	3.25	104.8	28.8
50	12.0	0.4	0.8	67.9	4.65	52.0	94.2	4.28	87.5	55.1	0.63	3.64	99.9	24.0
	16.0	0.7	1.7	69.0	4.71	52.9	94.6	4.29	89.8	56.6	0.63	3.50	101.8	25.7
	20.0	1.2	2.8	70.0	4.77	53.7	95.0	4.30	92.1	58.0	0.63	3.36	103.6	27.4
60	12.0	0.3	0.8	75.9	4.76	59.7	97.3	4.67	84.4	54.0	0.64	3.83	97.5	22.0
	16.0	0.7	1.6	77.1	4.82	60.6	97.7	4.68	86.6	55.4	0.64	3.68	99.2	23.5
	20.0	1.2	2.7	78.3	4.89	61.6	98.2	4.69	88.9	56.8	0.64	3.54	100.9	25.1
70	12.0	0.3	0.7	83.9	4.88	67.3	100.4	5.04	81.3	52.9	0.65	4.02	95.0	20.2
	16.0	0.7	1.5	85.2	4.94	68.4	100.9	5.06	83.5	54.2	0.65	3.86	96.6	21.6
	20.0	1.1	2.6	86.5	5.00	69.4	101.4	5.07	85.6	55.6	0.65	3.71	98.3	23.1
80	12.0	0.3	0.7	92.7	4.95	75.8	103.8	5.49	74.4	49.1	0.66	4.86	91.0	15.3
	16.0	0.6	1.5	94.1	5.01	77.0	104.3	5.50	76.6	50.5	0.66	4.63	92.4	16.5
	20.0	1.1	2.5	95.6	5.08	78.2	104.9	5.52	78.4	51.6	0.66	4.49	93.7	17.5
90	12.0	0.3	0.6	101.5	5.02	84.3	107.1	5.92	67.5	45.3	0.67	5.70	87.0	11.9
	16.0	0.6	1.4	103.0	5.09	85.7	107.7	5.94	69.7	46.7	0.67	5.44	88.2	12.8
	20.0	1.1	2.5	104.6	5.15	87.0	108.4	5.95	71.1	47.6	0.67	5.26	89.0	13.5
100	12.0	0.2	0.5	Operation not recommended					Operation not recommended					
	16.0	0.5	1.2						63.0	43.6	0.69	5.74	82.6	11.0
	20.0	1.0	2.3						64.0	44.0	0.69	5.56	82.9	11.5
110	12.0	0.2	0.4	Operation not recommended					Operation not recommended					
	16.0	0.5	1.2						55.7	39.7	0.71	6.01	76.2	9.3
	20.0	1.0	2.2						56.8	40.3	0.71	5.85	76.8	9.7
120	12.0	0.2	0.4	Operation not recommended					Operation not recommended					
	16.0	0.5	1.2						53.6	38.9	0.72	6.32	75.2	8.5
	20.0	0.9	2.2						54.8	39.5	0.72	6.14	75.7	8.9

Interpolation is permissible, extrapolation is not.

3/30/21

All entering air conditions are 80°F DB and 67°F WB in Cooling and 70°F DB in Heating.

All performance data is based upon the lower voltage of dual voltage units.

Operation below 60°F EWT requires optional insulated water/refrigerant circuit.

Operation below 40°F EWT is based upon 15% antifreeze solution.

See performance correction tables for operating conditions other than those listed above.



Contractor: \_\_\_\_\_ P.O.: \_\_\_\_\_

Engineer: \_\_\_\_\_

Project Name: \_\_\_\_\_ Unit Tag: \_\_\_\_\_

## 120 - Full Load Horizontal - Performance Data

### Capacity Data (3600 CFM)

EWT °F	WATER FLOW GPM	WPD		HEATING - EAT 70 °F					COOLING - EAT 80/67 °F					
		PSI	FT	HC	KW	HE	LAT	COP	TC	SC	S/T	KW	HR	EER
20	16.0	0.8	1.8	Operation not recommended					Operation not recommended					
	22.0	1.6	3.7											
	30.0	3.1	7.2	72.0	7.01	48.1	86.5	3.01						
30	16.0	0.8	1.8	Operation not recommended					Operation not recommended					
	22.0	1.5	3.5	84.5	7.32	59.5	89.7	3.38	140.2	94.8	0.68	5.85	160.1	24.0
	30.0	3.0	6.9	85.8	7.41	60.5	90.1	3.39	142.1	96.6	0.68	5.49	160.8	25.9
40	16.0	0.8	1.8	96.9	7.49	71.3	92.9	3.79	133.2	90.6	0.68	6.27	154.6	21.3
	22.0	1.4	3.2	101.2	7.73	74.8	94.0	3.84	137.3	93.7	0.68	6.11	158.1	22.5
	30.0	2.9	6.7	99.9	7.69	73.7	93.7	3.81	140.2	96.0	0.68	5.79	159.9	24.2
50	16.0	0.7	1.6	110.6	7.76	84.1	96.4	4.18	131.4	90.7	0.69	6.59	153.9	19.9
	22.0	1.3	3.0	112.0	7.85	85.3	96.8	4.19	134.3	92.7	0.69	6.37	156.1	21.1
	30.0	2.8	6.5	114.0	7.96	86.8	97.3	4.20	138.3	95.4	0.69	6.08	159.0	22.7
60	16.0	0.7	1.6	123.3	7.88	96.4	99.7	4.59	124.5	87.1	0.70	7.07	148.6	17.6
	22.0	1.3	3.0	125.0	7.97	97.8	100.1	4.60	127.3	89.0	0.70	6.84	150.6	18.6
	30.0	2.7	6.2	127.2	8.09	99.6	100.7	4.61	131.1	91.7	0.70	6.53	153.3	20.1
70	16.0	0.7	1.6	136.1	8.00	108.8	103.0	4.98	117.6	83.5	0.71	7.56	143.4	15.6
	22.0	1.2	2.8	137.9	8.09	110.3	103.5	4.99	120.3	85.4	0.71	7.31	145.2	16.4
	30.0	2.6	5.9	140.3	8.21	112.3	104.1	5.01	123.8	87.9	0.71	6.98	147.6	17.7
80	16.0	0.6	1.4	149.9	8.21	121.9	106.5	5.35	113.4	82.1	0.72	8.47	142.3	13.4
	22.0	1.2	2.8	152.0	8.31	123.7	107.1	5.36	116.4	84.4	0.72	8.08	144.0	14.4
	30.0	2.5	5.8	154.5	8.42	125.8	107.7	5.38	119.4	86.5	0.72	7.82	146.0	15.3
90	16.0	0.6	1.4	163.6	8.41	134.9	110.1	5.70	109.2	80.8	0.74	9.37	141.1	11.6
	22.0	1.2	2.8	166.2	8.53	137.1	110.7	5.71	112.6	83.3	0.74	8.94	143.1	12.6
	30.0	2.4	5.5	168.7	8.63	139.3	111.4	5.73	114.9	85.0	0.74	8.65	144.4	13.3
100	16.0	0.5	1.2	Operation not recommended					Operation not recommended					
	22.0	1.1	2.5						108.9	81.7	0.75	10.19	143.7	10.7
	30.0	2.3	5.3						110.6	82.3	0.74	9.87	144.2	11.2
110	16.0	0.5	1.2	Operation not recommended					Operation not recommended					
	22.0	1.1	2.5						104.1	78.5	0.75	11.39	142.9	9.1
	30.0	2.2	5.1						106.2	79.7	0.75	11.08	144.0	9.6
120	16.0	0.5	1.2	Operation not recommended					Operation not recommended					
	22.0	1.0	2.3						99.7	76.2	0.76	12.73	143.1	7.8
	30.0	2.1	4.9						101.8	77.4	0.76	12.36	144.0	8.2

Interpolation is permissible, extrapolation is not.

3/30/21

All entering air conditions are 80°F DB and 67°F WB in Cooling and 70°F DB in Heating.

All performance data is based upon the lower voltage of dual voltage units.

Operation below 60°F EWT requires optional insulated water/refrigerant circuit.

Operation below 40°F EWT is based upon 15% antifreeze solution.

See performance correction tables for operating conditions other than those listed above.

Contractor: \_\_\_\_\_ P.O.: \_\_\_\_\_

Engineer: \_\_\_\_\_

Project Name: \_\_\_\_\_ Unit Tag: \_\_\_\_\_

**Affinity YDL Series**  
**Single Capacity**  
**7 - 30 Tons 60Hz**



## 150 - Part Load Horizontal - Performance Data

### Capacity Data (2300 CFM)

EWT °F	WATER FLOW GPM	WPD		HEATING - EAT 70 °F					COOLING - EAT 80/67 °F					
		PSI	FT	HC	KW	HE	LAT	COP	TC	SC	S/T	KW	HR	EER
20	12.0	1.7	3.9	Operation not recommended					Operation not recommended					
	15.0	2.1	4.9											
	18.0	2.5	5.8	27.4	2.4	19.1	79.0	3.3						
30	12.0	1.6	3.7	Operation not recommended					Operation not recommended					
	15.0	2.0	4.6	36.1	3.18	25.3	82.6	3.33	84.9	62.6	0.74	3.20	95.8	26.6
	18.0	2.4	5.5	36.7	3.22	25.7	82.8	3.34	86.1	63.8	0.74	3.00	96.3	28.7
40	12.0	1.5	3.5	49.3	3.72	36.6	87.9	3.88	80.9	59.9	0.74	3.46	92.7	23.4
	15.0	1.9	4.4	57.7	4.22	43.3	91.2	4.01	83.6	62.1	0.74	3.36	95.0	24.8
	18.0	2.3	5.3	50.9	3.82	37.8	88.5	3.90	85.2	63.6	0.75	3.20	96.1	26.7
50	12.0	1.4	3.2	63.1	4.31	48.3	93.4	4.29	80.1	60.1	0.75	3.67	92.6	21.8
	15.0	1.8	4.2	64.0	4.36	49.1	93.8	4.30	82.2	61.6	0.75	3.53	94.2	23.3
	18.0	2.2	5.1	65.0	4.42	49.9	94.2	4.31	84.3	63.2	0.75	3.39	95.9	24.9
60	12.0	1.3	3.0	70.5	4.46	55.3	96.4	4.63	76.5	58.1	0.76	4.04	90.3	19.0
	15.0	1.7	3.9	71.6	4.52	56.2	96.8	4.65	78.5	59.7	0.76	3.88	91.8	20.2
	18.0	2.1	4.9	72.7	4.58	57.1	97.3	4.66	80.6	61.2	0.76	3.73	93.3	21.6
70	12.0	1.2	2.8	78.0	4.61	62.3	99.4	4.96	73.0	56.2	0.77	4.40	88.0	16.6
	15.0	1.6	3.7	79.2	4.67	63.3	99.9	4.97	74.9	57.7	0.77	4.23	89.3	17.7
	18.0	2.0	4.6	80.4	4.73	64.3	100.4	4.98	76.8	59.1	0.77	4.06	90.7	18.9
80	12.0	1.1	2.5	85.7	4.81	69.3	102.5	5.22	71.4	55.7	0.78	4.79	87.8	14.9
	15.0	1.5	3.5	87.1	4.87	70.4	103.1	5.24	73.5	57.3	0.78	4.57	89.1	16.1
	18.0	1.9	4.4	88.4	4.94	71.6	103.6	5.25	75.2	58.6	0.78	4.42	90.3	17.0
90	12.0	1.0	2.3	93.5	5.01	76.4	105.6	5.47	69.9	55.2	0.79	5.18	87.6	13.5
	15.0	1.4	3.2	95.0	5.08	77.6	106.2	5.48	72.1	57.0	0.79	4.94	89.0	14.6
	18.0	1.8	4.2	96.4	5.14	78.9	106.8	5.50	73.6	58.1	0.79	4.78	89.9	15.4
100	12.0	0.9	2.1	Operation not recommended					Operation not recommended					
	15.0	1.3	3.0						67.6	54.1	0.80	5.27	85.6	12.8
	18.0	1.7	3.9						68.7	54.6	0.79	5.11	86.1	13.4
110	12.0	0.8	1.8	Operation not recommended					Operation not recommended					
	15.0	1.2	2.8						62.4	50.2	0.80	5.58	81.5	11.2
	18.0	1.6	3.7						63.7	51.0	0.80	5.43	82.2	11.7
120	12.0	0.7	1.6	Operation not recommended					Operation not recommended					
	15.0	1.1	2.5						60.9	49.3	0.81	6.49	83.0	9.4
	18.0	1.5	3.5						61.0	50.0	0.82	6.30	82.5	9.7

Interpolation is permissible, extrapolation is not.

All entering air conditions are 80°F DB and 67°F WB in Cooling and 70°F DB in Heating.

All performance data is based upon the lower voltage of dual voltage units.

Operation below 60°F EWT requires optional insulated water/refrigerant circuit.

Operation below 40°F EWT is based upon 15% antifreeze solution.

See performance correction tables for operating conditions other than those listed above.

3/30/21

The manufacturer works continually to improve its products. As a result, the design and specifications of each product at the time of order may be changed without notice. Purchaser's approval of this data set signifies that the equipment is acceptable under the provisions of the job specification. Statements and other information contained herein are not express warranties and do not form the basis of any bargain between the parties, but are merely the manufacturer's opinion or commendation of its products. York and Affinity are registered trademarks of Johnson Controls, Inc., and are used with permission.

Contractor: \_\_\_\_\_ P.O.: \_\_\_\_\_

Engineer: \_\_\_\_\_

Project Name: \_\_\_\_\_ Unit Tag: \_\_\_\_\_

**Affinity YDL Series**  
**Single Capacity**  
**7 - 30 Tons 60Hz**



## 150 - Full Load Horizontal - Performance Data

### Capacity Data (4500 CFM)

EWT °F	WATER FLOW GPM	WPD		HEATING - EAT 70 °F					COOLING - EAT 80/67 °F					
		PSI	FT	HC	KW	HE	LAT	COP	TC	SC	S/T	KW	HR	EER
20	24.0	3.3	7.6	Operation not recommended					Operation not recommended					
	30.0	5.2	12.0											
	36.0	7.0	16.2	87.2	9.13	56.0	85.9	2.80						
30	24.0	3.2	7.4	Operation not recommended					Operation not recommended					
	30.0	5.1	11.8	95.1	9.16	63.8	87.6	3.04	170.0	109.9	0.65	6.50	192.1	26.2
	36.0	6.9	15.9	98.4	9.24	66.9	88.2	3.12	172.3	112.0	0.65	6.10	193.1	28.2
40	24.0	3.1	7.2	110.8	9.04	79.9	90.8	3.59	160.7	104.5	0.65	7.08	184.9	22.7
	30.0	5.0	11.6	115.3	9.22	83.8	91.7	3.66	166.0	108.4	0.65	6.88	189.4	24.1
	36.0	6.8	15.7	114.2	9.27	82.6	91.5	3.61	169.2	110.8	0.65	6.54	191.5	25.9
50	24.0	3.0	6.9	126.1	9.07	95.2	93.9	4.08	157.8	104.1	0.66	7.55	183.6	20.9
	30.0	4.9	11.3	128.1	9.18	96.7	94.3	4.09	161.9	106.9	0.66	7.26	186.7	22.3
	36.0	6.7	15.5	130.0	9.30	98.3	94.7	4.10	166.1	109.6	0.66	6.97	189.9	23.8
60	24.0	2.9	6.7	141.1	9.52	108.6	97.0	4.34	153.1	102.6	0.67	8.30	181.5	18.4
	30.0	4.8	11.1	143.3	9.64	110.4	97.5	4.36	157.2	105.3	0.67	7.98	184.4	19.7
	36.0	6.6	15.2	145.5	9.77	112.2	97.9	4.37	161.2	108.0	0.67	7.67	187.4	21.0
70	24.0	2.8	6.5	156.2	9.97	122.1	100.1	4.59	148.5	101.0	0.68	9.06	179.4	16.4
	30.0	4.7	10.9	158.6	10.10	124.1	100.6	4.60	152.4	103.6	0.68	8.71	182.1	17.5
	36.0	6.5	15.0	161.0	10.23	126.1	101.1	4.61	156.3	106.3	0.68	8.36	184.8	18.7
80	24.0	2.7	6.2	171.5	10.41	136.0	103.3	4.83	143.0	101.4	0.71	9.92	176.9	14.4
	30.0	4.6	10.6	174.2	10.54	138.2	103.8	4.84	147.1	104.3	0.71	9.46	179.4	15.6
	36.0	6.4	14.8	176.9	10.68	140.4	104.4	4.86	150.6	106.7	0.71	9.16	181.8	16.4
90	24.0	2.6	6.0	186.9	10.84	149.9	106.5	5.05	137.6	101.8	0.74	10.78	174.3	12.8
	30.0	4.5	10.4	189.8	10.99	152.3	107.1	5.06	141.9	105.0	0.74	10.28	177.0	13.8
	36.0	6.3	14.6	192.7	11.12	154.8	107.7	5.08	144.8	107.2	0.74	9.95	178.7	14.6
100	24.0	2.5	5.8	Operation not recommended					Operation not recommended					
	30.0	4.4	10.2						136.0	101.3	0.75	11.41	174.9	11.9
	36.0	6.2	14.3						138.1	102.2	0.74	11.05	175.7	12.5
110	24.0	2.4	5.5	Operation not recommended					Operation not recommended					
	30.0	4.3	9.9						128.7	95.7	0.74	12.48	171.3	10.3
	36.0	6.1	14.1						131.3	97.2	0.74	12.14	172.7	10.8
120	24.0	2.3	5.3	Operation not recommended					Operation not recommended					
	30.0	4.2	9.7						122.2	91.0	0.74	14.35	171.1	8.5
	36.0	6.0	13.9						124.8	92.4	0.74	13.93	172.3	9.0

Interpolation is permissible, extrapolation is not.

3/30/21

All entering air conditions are 80°F DB and 67°F WB in Cooling and 70°F DB in Heating.

All performance data is based upon the lower voltage of dual voltage units.

Operation below 60°F EWT requires optional insulated water/refrigerant circuit.

Operation below 40°F EWT is based upon 15% antifreeze solution.

See performance correction tables for operating conditions other than those listed above.





Contractor: \_\_\_\_\_ P.O.: \_\_\_\_\_

Engineer: \_\_\_\_\_

Project Name: \_\_\_\_\_ Unit Tag: \_\_\_\_\_

## 180 - Part Load Horizontal - Performance Data

### Capacity Data (2800 CFM)

EWT °F	WATER FLOW GPM	WPD		HEATING - EAT 70 °F					COOLING - EAT 80/67 °F					
		PSI	FT	HC	KW	HE	LAT	COP	TC	SC	S/T	KW	HR	EER
20	20.0	1.7	3.9	Operation not recommended					Operation not recommended					
	24.0	2.2	5.1											
	28.0	2.6	6.0	44.6	4.32	29.9	82.7	3.03						
30	20.0	1.6	3.7	Operation not recommended					Operation not recommended					
	24.0	2.1	4.9	52.8	4.79	36.4	85.4	3.23	98.2	68.3	0.70	3.71	110.8	26.5
	28.0	2.5	5.8	54.4	4.91	37.6	86.0	3.25	99.5	69.7	0.70	3.48	111.4	28.6
40	20.0	1.5	3.5	62.8	5.07	45.4	88.8	3.62	92.9	66.9	0.72	4.12	107.0	22.5
	24.0	2.0	4.6	67.0	5.26	49.0	90.1	3.73	95.9	68.8	0.72	4.00	109.6	24.0
	28.0	2.4	5.5	64.7	5.21	46.9	89.4	3.64	97.8	70.4	0.72	3.81	110.8	25.7
50	20.0	1.4	3.2	72.8	5.36	54.5	92.1	3.98	91.3	67.6	0.74	4.47	106.6	20.4
	24.0	1.9	4.4	73.9	5.43	55.3	92.4	3.99	93.7	69.3	0.74	4.30	108.4	21.8
	28.0	2.3	5.3	75.0	5.50	56.2	92.8	4.00	96.1	71.1	0.74	4.13	110.2	23.3
60	20.0	1.3	3.0	80.8	5.54	61.9	94.7	4.28	88.8	65.3	0.74	4.99	105.8	17.8
	24.0	1.8	4.2	82.1	5.61	62.9	95.1	4.29	91.1	67.0	0.74	4.80	107.5	19.0
	28.0	2.2	5.1	83.3	5.68	63.9	95.5	4.30	93.5	68.7	0.74	4.61	109.2	20.3
70	20.0	1.2	2.8	88.9	5.71	69.4	97.4	4.56	86.3	63.0	0.73	5.51	105.1	15.6
	24.0	1.7	3.9	90.2	5.79	70.5	97.8	4.57	88.5	64.6	0.73	5.30	106.6	16.7
	28.0	2.1	4.9	91.6	5.86	71.6	98.3	4.58	90.8	66.3	0.73	5.09	108.2	17.8
80	20.0	1.1	2.5	97.5	5.88	77.5	100.3	4.86	83.0	62.2	0.75	6.03	103.6	13.8
	24.0	1.6	3.7	99.0	5.96	78.7	100.8	4.87	85.4	64.0	0.75	5.76	105.1	14.8
	28.0	2.0	4.6	100.6	6.03	80.0	101.3	4.89	87.4	65.5	0.75	5.57	106.4	15.7
90	20.0	1.0	2.3	106.2	6.05	85.6	103.1	5.15	79.8	61.4	0.77	6.55	102.2	12.2
	24.0	1.5	3.5	107.9	6.12	87.0	103.7	5.16	82.3	63.4	0.77	6.25	103.6	13.2
	28.0	1.9	4.4	109.5	6.20	88.3	104.2	5.18	84.0	64.7	0.77	6.05	104.6	13.9
100	20.0	0.9	2.1	Operation not recommended					Operation not recommended					
	24.0	1.4	3.2						79.6	62.5	0.78	6.75	102.6	11.8
	28.0	1.8	4.2						80.8	63.0	0.78	6.54	103.1	12.4
110	20.0	0.8	1.8	Operation not recommended					Operation not recommended					
	24.0	1.3	3.0						76.0	60.4	0.79	7.22	100.7	10.5
	28.0	1.7	3.9						77.6	61.3	0.79	7.02	101.6	11.1
120	20.0	0.7	1.6	Operation not recommended					Operation not recommended					
	24.0	1.2	2.8						74.2	59.9	0.81	7.93	101.3	9.4
	28.0	1.6	3.7						75.8	60.8	0.80	7.70	102.1	9.8

Interpolation is permissible, extrapolation is not.

3/30/21

All entering air conditions are 80°F DB and 67°F WB in Cooling and 70°F DB in Heating.

All performance data is based upon the lower voltage of dual voltage units.

Operation below 60°F EWT requires optional insulated water/refrigerant circuit.

Operation below 40°F EWT is based upon 15% antifreeze solution.

See performance correction tables for operating conditions other than those listed above.

Contractor: \_\_\_\_\_ P.O.: \_\_\_\_\_

Engineer: \_\_\_\_\_

Project Name: \_\_\_\_\_ Unit Tag: \_\_\_\_\_

**Affinity YDL Series**  
**Single Capacity**  
**7 - 30 Tons 60Hz**



## 180 - Full Load Horizontal - Performance Data

### Capacity Data (5200 CFM)

EWT °F	WATER FLOW GPM	WPD		HEATING - EAT 70 °F					COOLING - EAT 80/67 °F					
		PSI	FT	HC	KW	HE	LAT	COP	TC	SC	S/T	KW	HR	EER
20	22.0	1.9	4.4	Operation not recommended					Operation not recommended					
	34.0	3.1	7.2	Operation not recommended					Operation not recommended					
	45.0	4.3	9.9	103.2	11.02	65.6	86.4	2.74	Operation not recommended					
30	22.0	1.8	4.2	Operation not recommended					Operation not recommended					
	34.0	3.0	6.9	120.4	11.51	81.1	89.4	3.07	194.1	128.3	0.66	9.19	225.5	21.1
	45.0	4.2	9.7	122.2	11.65	82.5	89.8	3.07	198.1	130.7	0.66	8.89	228.4	22.3
40	22.0	1.7	3.9	137.8	11.87	97.3	92.5	3.40	184.2	123.4	0.67	10.20	219.0	18.0
	34.0	2.9	6.7	145.7	12.23	104.0	93.9	3.49	189.6	127.1	0.67	9.77	222.9	19.4
	45.0	4.1	9.5	142.1	12.18	100.6	93.3	3.42	193.9	129.8	0.67	9.42	226.0	20.6
50	22.0	1.6	3.7	157.1	12.38	114.9	96.0	3.72	180.1	122.5	0.68	10.78	216.9	16.7
	34.0	2.8	6.5	159.7	12.55	116.9	96.4	3.73	185.1	125.8	0.68	10.35	220.4	17.9
	45.0	4.0	9.2	162.0	12.70	118.7	96.8	3.74	189.6	128.9	0.68	9.95	223.5	19.1
60	22.0	1.5	3.5	173.2	12.71	129.9	98.8	3.99	176.8	122.0	0.69	11.56	216.3	15.3
	34.0	2.7	6.2	176.0	12.88	132.1	99.3	4.00	181.6	125.3	0.69	11.10	219.5	16.4
	45.0	3.8	8.8	178.6	13.04	134.1	99.8	4.01	186.1	128.4	0.69	10.68	222.5	17.4
70	22.0	1.4	3.2	189.3	13.05	144.8	101.7	4.25	173.5	121.4	0.70	12.35	215.6	14.0
	34.0	2.6	6.0	192.4	13.22	147.3	102.3	4.27	178.2	124.8	0.70	11.85	218.7	15.0
	45.0	3.6	8.3	195.2	13.38	149.5	102.8	4.28	182.6	127.8	0.70	11.40	221.5	16.0
80	22.0	1.3	3.0	206.8	13.40	161.1	104.8	4.52	169.7	116.3	0.69	13.32	215.1	12.7
	34.0	2.5	5.8	210.1	13.57	163.7	105.4	4.54	174.7	119.7	0.69	12.71	218.0	13.7
	45.0	3.5	8.1	213.2	13.74	166.3	106.0	4.55	178.6	122.4	0.69	12.30	220.6	14.5
90	22.0	1.2	2.8	224.3	13.75	177.4	107.9	4.78	165.9	111.1	0.67	14.30	214.7	11.6
	34.0	2.4	5.5	227.7	13.93	180.2	108.6	4.79	171.1	114.6	0.67	13.64	217.6	12.5
	45.0	3.3	7.6	231.2	14.10	183.1	109.2	4.81	174.6	117.0	0.67	13.20	219.6	13.2
100	22.0	1.1	2.5	Operation not recommended					Operation not recommended					
	34.0	2.3	5.3	Operation not recommended					167.9	113.3	0.67	14.93	218.9	11.2
	45.0	3.2	7.4	Operation not recommended					170.5	114.2	0.67	14.45	219.8	11.8
110	22.0	1.0	2.3	Operation not recommended					Operation not recommended					
	34.0	2.2	5.1	Operation not recommended					163.1	109.8	0.67	16.14	218.1	10.1
	45.0	3.1	7.2	Operation not recommended					166.4	111.5	0.67	15.70	220.0	10.6
120	22.0	0.9	2.1	Operation not recommended					Operation not recommended					
	34.0	2.1	4.9	Operation not recommended					158.4	108.4	0.68	17.82	219.2	8.9
	45.0	3.0	6.9	Operation not recommended					161.8	110.0	0.68	17.30	220.8	9.4

Interpolation is permissible, extrapolation is not.

3/30/21

All entering air conditions are 80°F DB and 67°F WB in Cooling and 70°F DB in Heating.

All performance data is based upon the lower voltage of dual voltage units.

Operation below 60°F EWT requires optional insulated water/refrigerant circuit.

Operation below 40°F EWT is based upon 15% antifreeze solution.

See performance correction tables for operating conditions other than those listed above.



Contractor: \_\_\_\_\_ P.O.: \_\_\_\_\_

Engineer: \_\_\_\_\_

Project Name: \_\_\_\_\_ Unit Tag: \_\_\_\_\_



# Wiring Schematics cont.

## Single Compressor 208-230/60/3

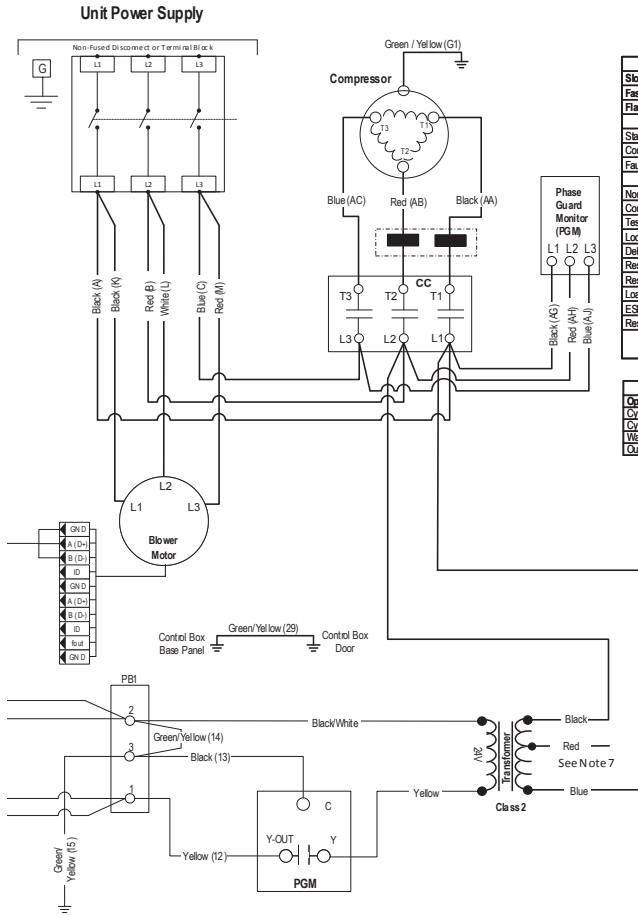

Aurora LED Flash Codes			
Slow Flash	1 second on and 1 second off		
Fast Flash	100 milliseconds on and 100 milliseconds off		
Flash Code	100 milliseconds on and 400 milliseconds off with a 2 second pause before repeating		
Random Start Delay			
Status LED (LED3, Green)	Fast Flash		
Configuration LED (LED2, Yellow)	Fast Flash		
Fault LED (LED1, Red)	Fast Flash		
Status LED (LED3, Green)	Configuration LED (LED2, Yellow)	Fault LED (LED1, Red)	
Normal Mode	ON	No Software Override	Flash ECM Setting
Control is Non-Functional	OFF	DIP Switch Override	Slow Flash
Test Mode	Slow Flash	ECM Contigue Mode	Fast Flash
Lockout Active	Fast Flash	Reset Contigue Mode	Off
Dehumidification Mode	Flash Code 2		
Resealed	Flash Code 3		
Resealed	Flash Code 4		
Load Shed	Flash Code 5		
ESD	Flash Code 6		
Resealed	Flash Code 7		
		Low Air Coil Limit Lockout - FP2	Flash Code 4
		Low Water Coil Limit Lockout - FP1	Flash Code 5
		Loss of Charge Lockout	Flash Code 6
		Condensate Overflow Lockout	Flash Code 7
		Over/Under Voltage Shutdown	Flash Code 8
		Resealed	Flash Code 9
		Compressor Monitor Lockout	Flash Code 10
		Air/Water Coil Limit Sensor Error	Flash Code 11

Accessory Relay			
Operation	SW2-4	SW2-5	
Cycle with Blower	On	On	
Cycle with Compressor	Off	Off	
Water Valve Slow Open	On	Off	
Outdoor Air Damper	Off	On	

Aurora Timing Events		
Event	Normal Mode	Test Mode
Random Start Delay	5 to 80 seconds	1 second
Compressor On Delay	5 seconds	< 1 second
Compressor Minimum On Time	2 minutes	5 seconds
Compressor Short Cycle Delay	4 minutes	15 seconds
Blower Off Delay	30 seconds	2 seconds
Fault Recognition Delay - High Pressure	Less than 1 second	Less than 1 second
Start-Up Bypass - Low Pressure	2 minutes	30 seconds
Fault Recognition Delay - Low Pressure	30 seconds	30 seconds
Start-Up Bypass - Low Water/Air Coil Limit	2 minutes	30 seconds
Fault Recognition Delay - Low Water/Air Coil Limit	30 seconds	30 seconds
Fault Recognition Delay - Condensate Overflow	30 seconds	30 seconds
Thermostat Call Recognition Time	2 seconds	2 seconds
Auxiliary Heat Staging Delay	5 minutes	20 seconds
Emergency Heat Staging Delay	2 minutes	7.5 seconds
Water Valve Slow Open Delay	90 seconds	90 seconds
Reheat Delay	30 seconds	30 seconds

**Notes:**

- 1 - P1 (screw terminals) and P9 (Molex connector) are adjacent and share common terminals in the same order.
- 2 - Optional factory installed hot gas reheat or modulating hot gas reheat.
- 3 - Optional factory installed internal isolation valve.
- 4 - Optional water side economizer.
- 5 - See supplemental schematic for AXB and/or UPC connections.
- 6 - LAT location with Aurora Base Controls, FP2 with Aurora Advanced and Premium Controls
- 7 - Swap blue and red leads for 208V operation.

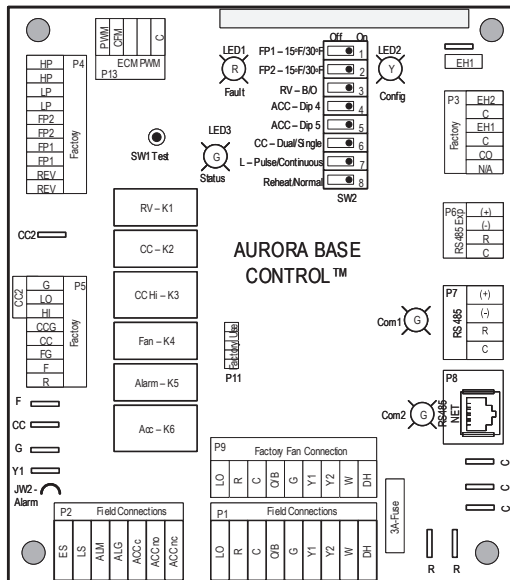

**Legend**

The legend defines the symbols used in the wiring diagrams:

- Factory Low Voltage Wiring (solid line)
- Factory Line Voltage Wiring (dashed line)
- Field Low Voltage Wiring (dotted line)
- Field Line Voltage Wiring (dash-dot line)
- Optional Block (dashed line with a box)
- DC Voltage PCB Traces (solid line with a box)
- Field Zone Sensor Wiring (dotted line with a box)
- Internal Junction (circle with a dot)
- Quick Connect Terminal (circle with a dot and a line)
- Field Wiring Lug (circle with a dot and a line)
- Ground (circle with a cross)
- Relay Contacts - N.O., N.C. (circle with a cross and a line)
- Capacitor (two parallel lines)
- Fuse (circle with a cross and a line)
- Current Transducer (circle with a cross and a line)
- Thermistor (circle with a cross and a line)
- Relay Coil (circle with a cross and a line)
- Switch - Condensate Overflow (circle with a cross and a line)
- Switch - High pressure (circle with a cross and a line)
- Switch - Low pressure (circle with a cross and a line)
- Polarized connector (circle with a cross and a line)
- Pin Number Designation on Twist-Lock Connector (circle with a cross and a line)
- Light Emitting Diode - Green (circle with a cross and a line)
- Light Emitting Diode - Yellow (circle with a cross and a line)
- Light Emitting Diode - Red (circle with a cross and a line)

Additional abbreviations:

- CC - Compressor Contactor
- CO - Condensate Overflow Sensor
- ES - Emergency Shutdown
- EW - Entering Water Temp Sensor
- HP - High Pressure Switch
- LAT - Leaving Air Temp
- LWT - Leaving Water Temp
- LP - Low Pressure Switch
- SW - Push button
- SW2 - DIP package 8 position
- RV - Reversing Valve Coil
- PGM - Phase Guard Monitor
- RH - Reheat Valve Coil

The manufacturer works continually to improve its products. As a result, the design and specifications of each product at the time of order may be changed without notice. Purchaser's approval of this data set signifies that the equipment is acceptable under the provisions of the job specification. Statements and other information contained herein are not express warranties and do not form the basis of any bargain between the parties, but are merely the manufacturer's opinion or commendation of its products. York and Affinity are registered trademarks of Johnson Controls, Inc., and are used with permission.

Contractor: \_\_\_\_\_ P.O.: \_\_\_\_\_  
 Engineer: \_\_\_\_\_  
 Project Name: \_\_\_\_\_ Unit Tag: \_\_\_\_\_

**Affinity YDL Series**  
**Single Capacity**  
**7 - 30 Tons 60Hz**



# Wiring Schematics cont.

## Single Compressor 460/60/3

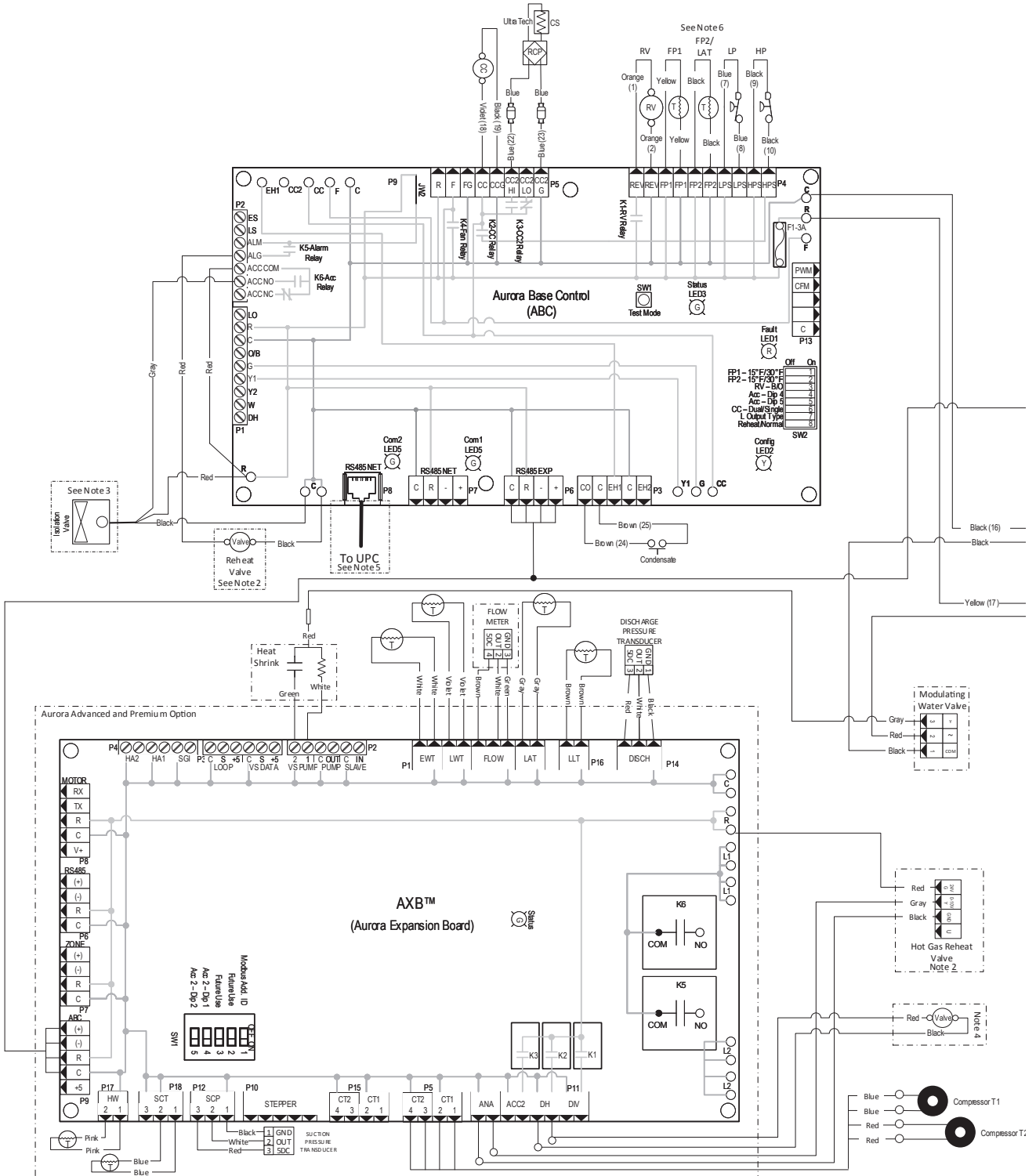

The manufacturer works continually to improve its products. As a result, the design and specifications of each product at the time of order may be changed without notice. Purchaser's approval of this data set signifies that the equipment is acceptable under the provisions of the job specification. Statements and other information contained herein are not express warranties and do not form the basis of any bargain between the parties, but are merely the manufacturer's opinion or commendation of its products. York and Affinity are registered trademarks of Johnson Controls, Inc., and are used with permission.

Contractor: \_\_\_\_\_ P.O.: \_\_\_\_\_  
 Engineer: \_\_\_\_\_  
 Project Name: \_\_\_\_\_ Unit Tag: \_\_\_\_\_



# Wiring Schematics cont.

## Single Compressor 460/60/3

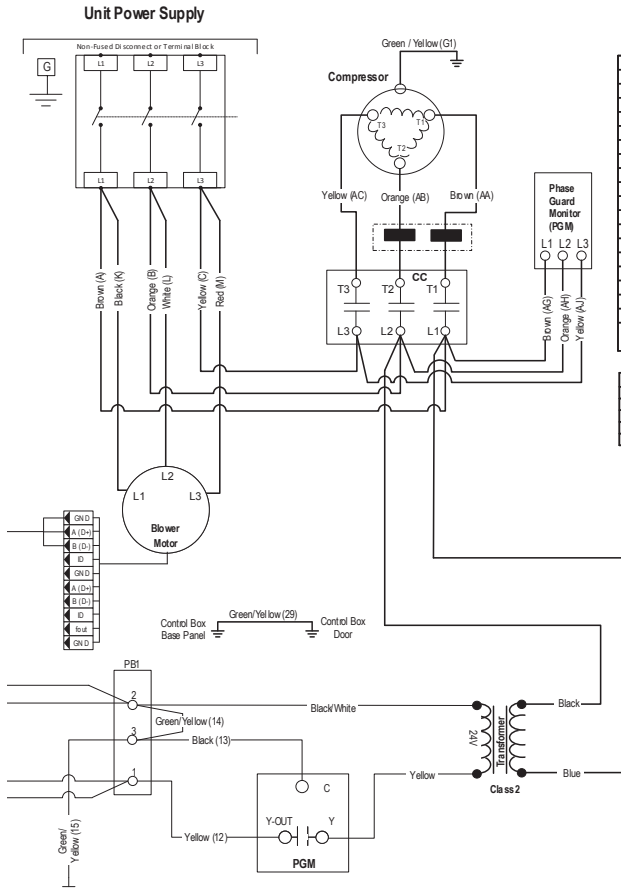

Aurora LED Flash Codes					
Slow Flash	1 second on and 1 second off				
Fast Flash	100 milliseconds on and 100 milliseconds off				
Flash Code	100 milliseconds on and 400 milliseconds off with a 2 second pause before repeating				
Random Start Delay					
Status LED (LED3, Green)	Fast Flash				
Configuration LED (LED2, Yellow)	Fast Flash				
Fault LED (LED1, Red)	Fast Flash				
Status LED (LED3, Green)	Configuration LED (LED2, Yellow)	Fault LED (LED1, Red)			
Normal Mode	ON	No Software Override	Flash ECM Settings	Normal Mode	OFF
Control is Non-Functional	OFF	DP Switch Override	Slow Flash	Input Fault Lockout	Flash Code 1
Test Mode	Slow Flash	ECM Config Mode	Fast Flash	High Pressure Lockout	Flash Code 2
Lockout Active	Fast Flash	Reset Config Mode	Off	Low Pressure Lockout	Flash Code 3
Dehumidification Mode	Flash Code 2			Low Air Coil Limit Lockout - FP2	Flash Code 4
Reserved	Flash Code 3			Low Water Coil Limit Lockout - FP1	Flash Code 5
Reserved	Flash Code 4			Loss of Charge Lockout	Flash Code 6
Load Shed	Flash Code 5			Condensate Overflow Lockout	Flash Code 7
ESD	Flash Code 6			Over/Under Voltage Shutdown	Flash Code 8
Reserved	Flash Code 7			Compressor Monitor Lockout	Flash Code 9
				Air/Water Coil Limit Sensor Error	Flash Code 10

Operation	Accessory Relay	SW2-1	SW2-3
Cycle with Blower	On	On	On
Cycle with Compressor	Off	Off	Off
Water Valve Slow Open	On	Off	On
Outdoor Air Damper	Off	On	On

Aurora Timing Events		
Event	Normal Mode	Test Mode
Random Start Delay	5 to 80 seconds	1 second
Compressor On Delay	5 seconds	< 1 second
Compressor Minimum On Time	2 minutes	5 seconds
Compressor Short Cycle Delay	4 minutes	15 seconds
Blower Off Delay	30 seconds	2 seconds
Fault Recognition Delay - High Pressure	Less than 1 second	Less than 1 second
Start-Up Bypass - Low Pressure	2 minutes	30 seconds
Fault Recognition Delay - Low Pressure	30 seconds	30 seconds
Start-Up Bypass - Low Water/Air Coil Limit	2 minutes	30 seconds
Fault Recognition Delay - Low Water/Air Coil Limit	30 seconds	30 seconds
Fault Recognition Delay - Condensate Overflow	30 seconds	30 seconds
Thermostat Call Recognition Time	2 seconds	2 seconds
Auxiliary Heat Staging Delay	5 minutes	20 seconds
Emergency Heat Staging Delay	2 minutes	7.5 seconds
Water Valve Slow Open Delay	90 seconds	90 seconds
Reheat Delay	30 seconds	30 seconds

**Notes:**

- 1 - P1 (screw terminals) and P9 (Molex connector) are adjacent and share common terminals in the same or 18V.
- 2 - Optional factory installed hot gas reheat.
- 3 - Optional factory installed internal isolation valve.
- 4 - Optional water-side economizer.
- 5 - See supplemental schematic for AXB and/or LPC connections.
- 6 - LAT location with Aurora Base Controls, FP2 with Aurora Advanced and Premium Controls.

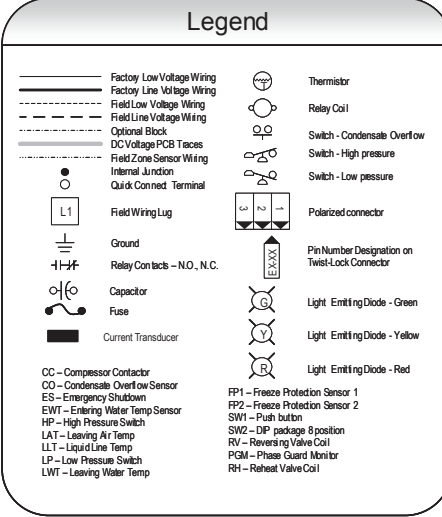
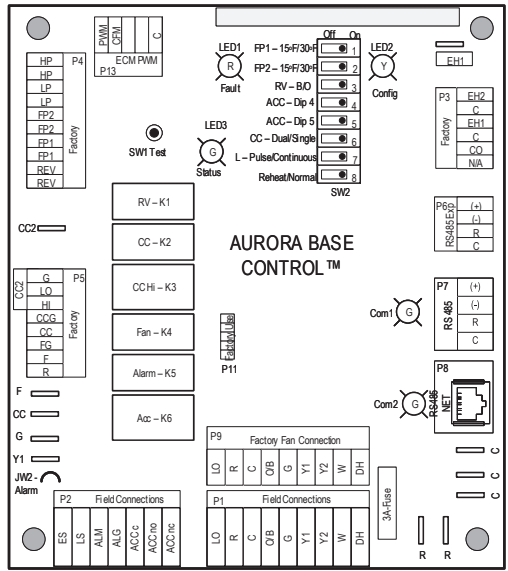

Contractor: \_\_\_\_\_ P.O.: \_\_\_\_\_

Engineer: \_\_\_\_\_

Project Name: \_\_\_\_\_ Unit Tag: \_\_\_\_\_

Affinity YDL Series  
Single Capacity  
7 - 30 Tons 60Hz



# Wiring Schematics cont.

## Dual Compressor 208-230/60/3

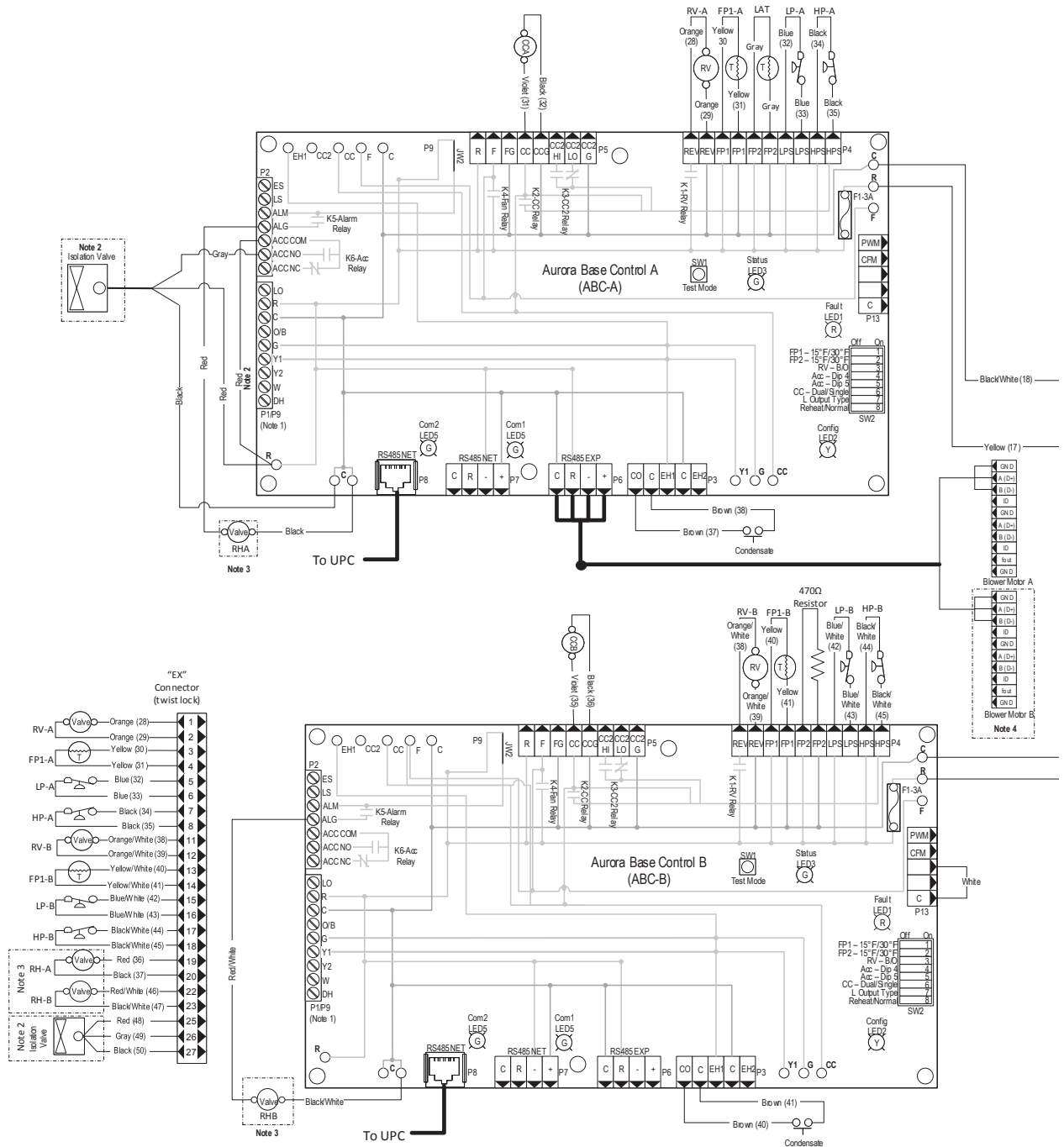

The manufacturer works continually to improve its products. As a result, the design and specifications of each product at the time of order may be changed without notice. Purchaser's approval of this data set signifies that the equipment is acceptable under the provisions of the job specification. Statements and other information contained herein are not express warranties and do not form the basis of any bargain between the parties, but are merely the manufacturer's opinion or commendation of its products. York and Affinity are registered trademarks of Johnson Controls, Inc., and are used with permission.

Contractor: \_\_\_\_\_ P.O.: \_\_\_\_\_

Engineer: \_\_\_\_\_

Project Name: \_\_\_\_\_ Unit Tag: \_\_\_\_\_

**Affinity YDL Series**  
**Single Capacity**  
**7 - 30 Tons 60Hz**



# Wiring Schematics cont.

## Dual Compressor 208-230/60/3

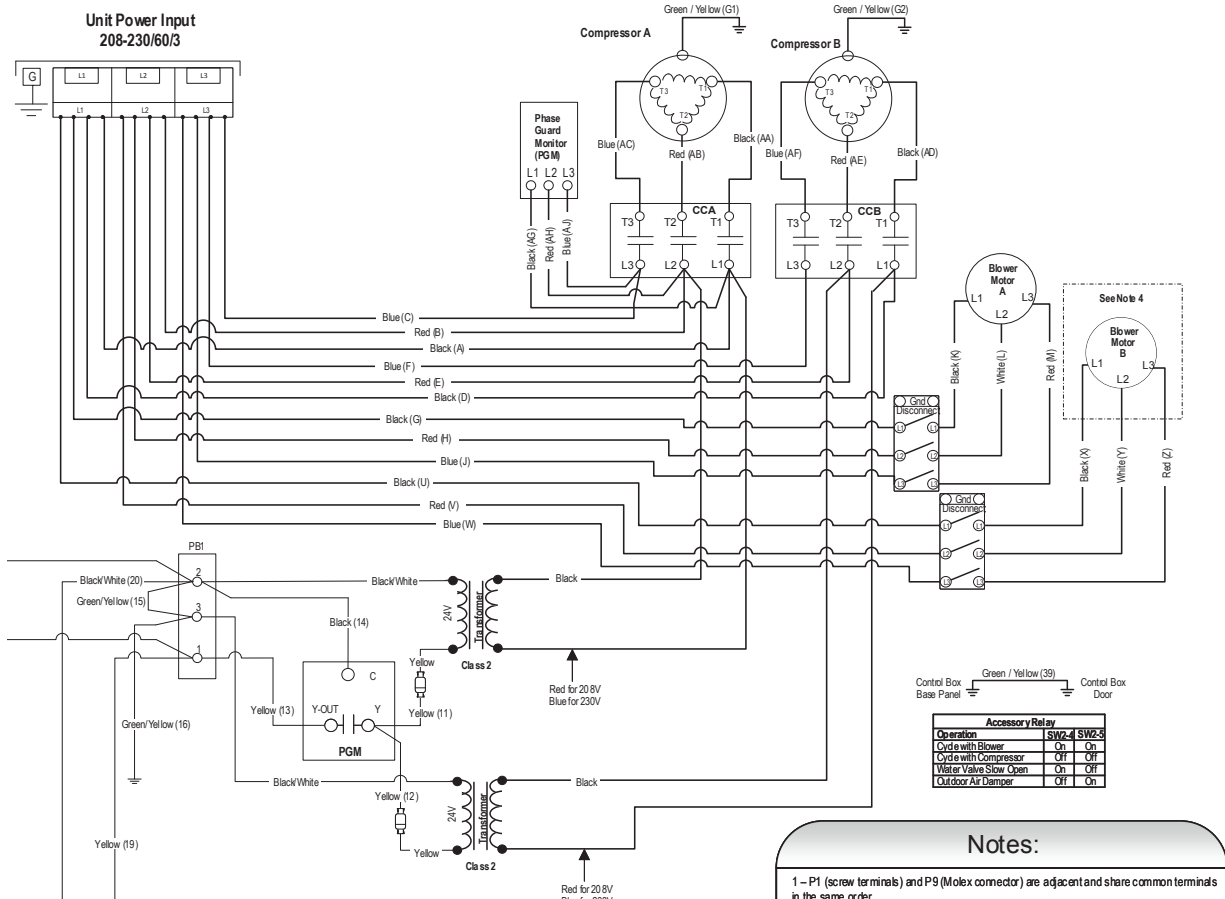

**Notes:**

- 1 - P1 (screw terminals) and P9 (Molex connector) are adjacent and share common terminals in the same order.
- 2 - Optional isolation water valve.
- 3 - Optional hot gas reheat.
- 4 - Sizes 240-360 equipped with two blowers.

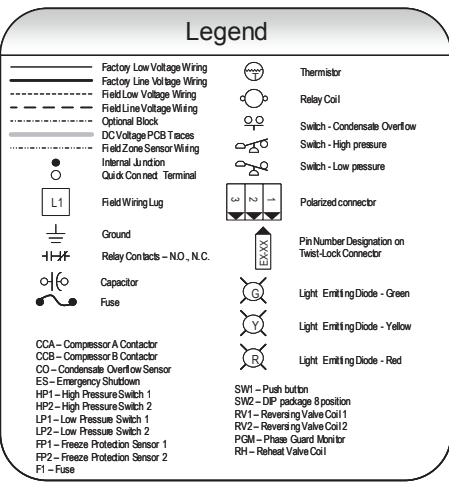
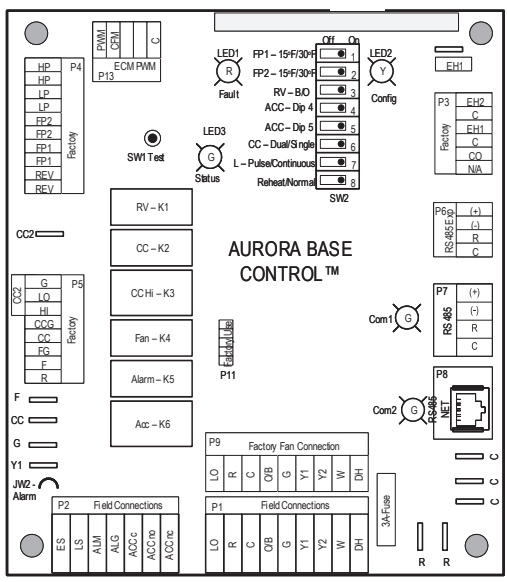

The manufacturer works continually to improve its products. As a result, the design and specifications of each product at the time of order may be changed without notice. Purchaser's approval of this data set signifies that the equipment is acceptable under the provisions of the job specification. Statements and other information contained herein are not express warranties and do not form the basis of any bargain between the parties, but are merely the manufacturer's opinion or commendation of its products. York and Affinity are registered trademarks of Johnson Controls, Inc., and are used with permission.



Contractor: \_\_\_\_\_ P.O.: \_\_\_\_\_

Engineer: \_\_\_\_\_

Project Name: \_\_\_\_\_ Unit Tag: \_\_\_\_\_

Affinity YDL Series  
Single Capacity  
7 - 30 Tons 60Hz



# Wiring Schematics cont.

## Dual Compressor 460/60/3

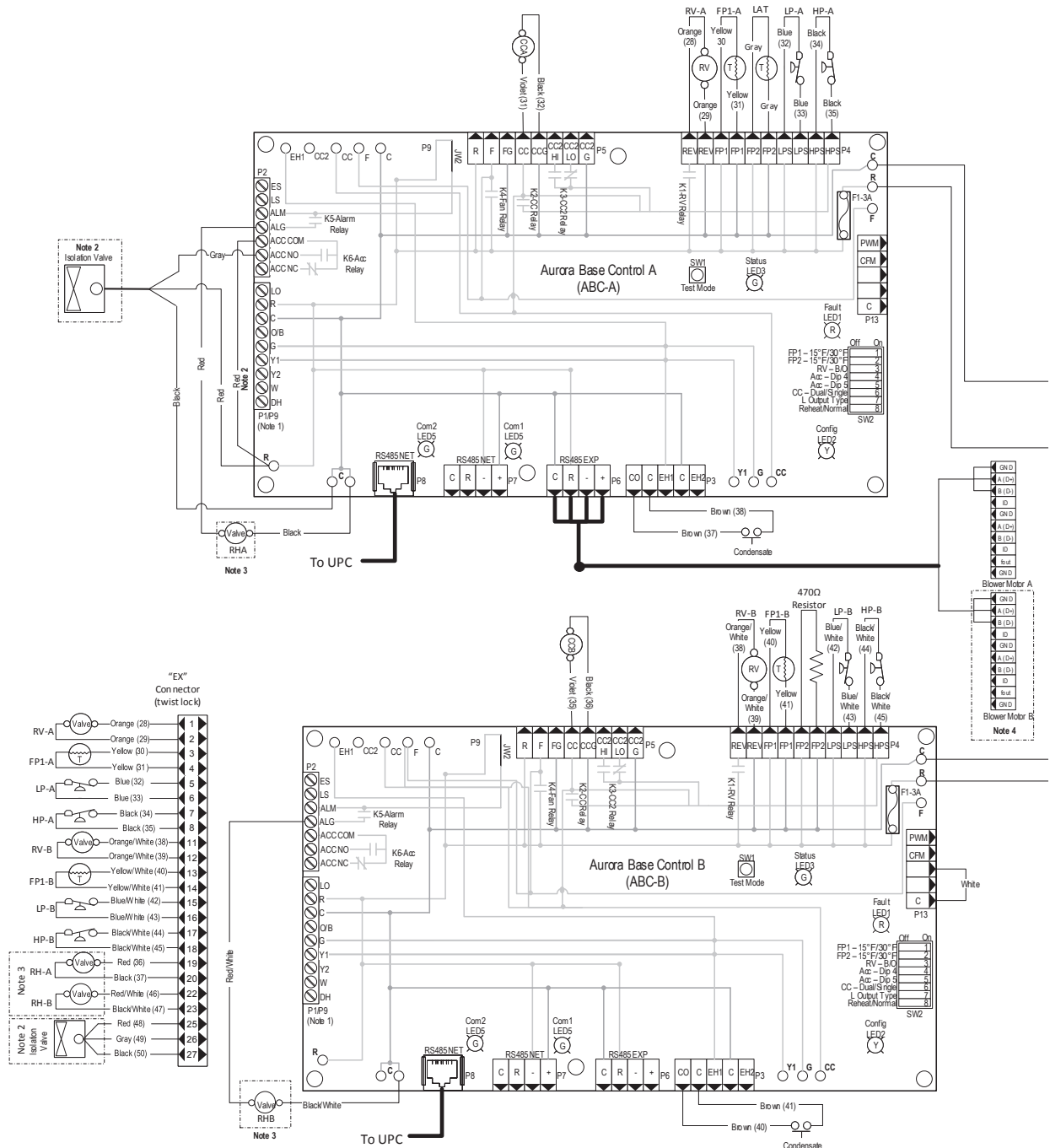

The manufacturer works continually to improve its products. As a result, the design and specifications of each product at the time of order may be changed without notice. Purchaser's approval of this data set signifies that the equipment is acceptable under the provisions of the job specification. Statements and other information contained herein are not express warranties and do not form the basis of any bargain between the parties, but are merely the manufacturer's opinion or commendation of its products. York and Affinity are registered trademarks of Johnson Controls, Inc., and are used with permission.

Contractor: \_\_\_\_\_ P.O.: \_\_\_\_\_

Engineer: \_\_\_\_\_

Project Name: \_\_\_\_\_ Unit Tag: \_\_\_\_\_

Affinity YDL Series  
Single Capacity  
7 - 30 Tons 60Hz



# Wiring Schematics cont.

## Dual Compressor 460/60/3

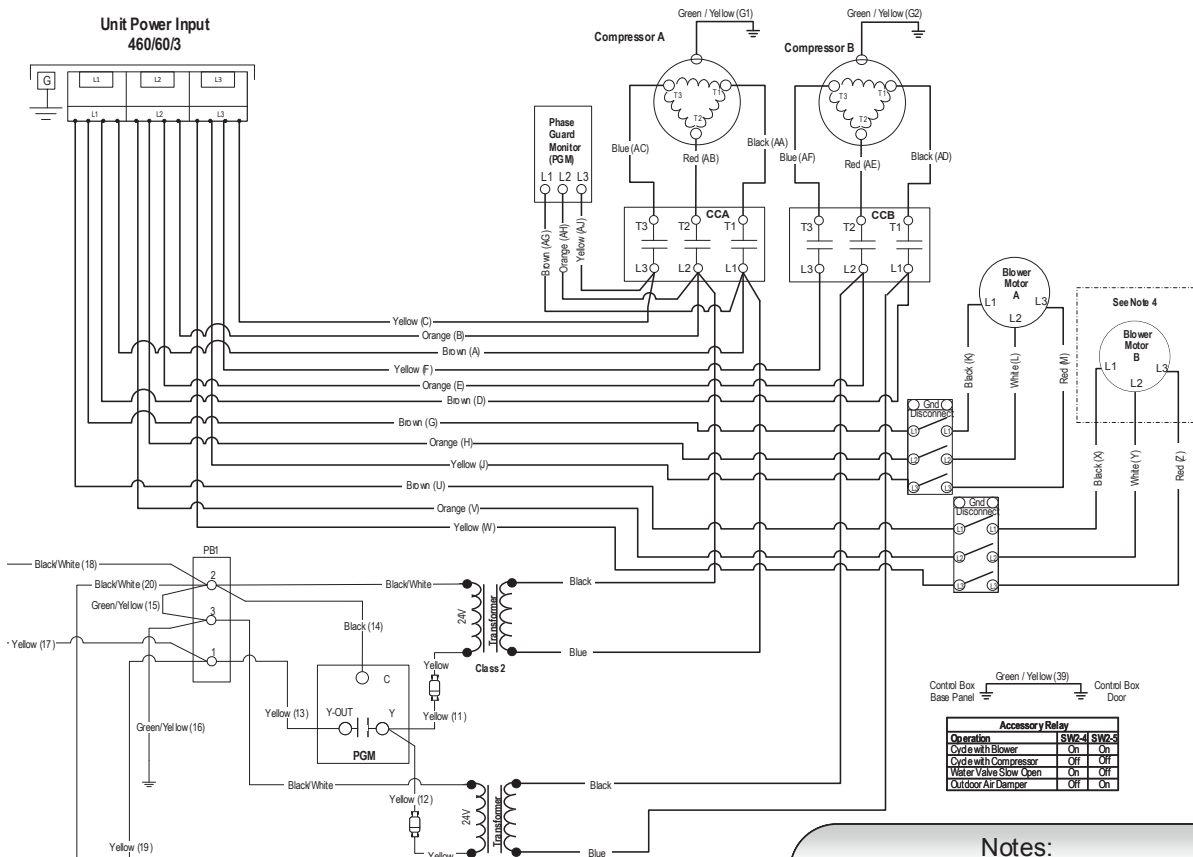

Accessory Relay		
Operation	SW2-4	SW2-3
Cycle with Blower	On	On
Cycle with Compressor	Off	Off
Water Valve Slow Open	On	Off
Outdoor Air Damper	Off	On

**Notes:**

- 1 - P1 (screw terminals) and P9 (Molex connector) are adjacent and share common terminals in the same order.
- 2 - Optional isolation water valve.
- 3 - Optional hot gas reheat.
- 4 - Sizes 240-360 equipped with two blowers.

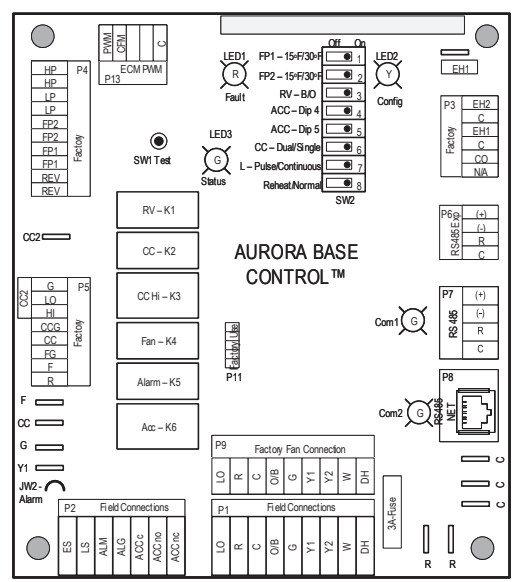

**Legend**

- Factory Low Voltage Wiring
- Factory Line Voltage Wiring
- Field Low Voltage Wiring
- Field Line Voltage Wiring
- Optional Block
- DC Voltage PCB Traces
- Field Zone Sensor Wiring
- Internal Junction
- Quick Connect Terminal
- Field Wiring Lug
- Ground
- Relay Contacts - N.O., N.C.
- Capacitor
- Fuse
- Thermistor
- Relay Coil
- Switch - Condensate Overflow
- Switch - High pressure
- Switch - Low pressure
- Polarized connector
- Pin Number Designation on Twist-Lock Connector
- Light Emitting Diode - Green
- Light Emitting Diode - Yellow
- Light Emitting Diode - Red

CCA - Compressor A Contactor  
 CCB - Compressor B Contactor  
 CO - Condensate Overflow Sensor  
 ES - Emergency Shutdown  
 HP1 - High Pressure Switch 1  
 HP2 - High Pressure Switch 2  
 LP1 - Low Pressure Switch 1  
 LP2 - Low Pressure Switch 2  
 FP1 - Freeze Protection Sensor 1  
 FP2 - Freeze Protection Sensor 2  
 F1 - Fuse

SW1 - Push button  
 SW2 - DP package 8 position  
 RV1 - Reversing Valve Coil 1  
 RV2 - Reversing Valve Coil 2  
 PGM - Phase Guard Monitor  
 RH - Reheat Valve Coil

The manufacturer works continually to improve its products. As a result, the design and specifications of each product at the time of order may be changed without notice. Purchaser's approval of this data set signifies that the equipment is acceptable under the provisions of the job specification. Statements and other information contained herein are not express warranties and do not form the basis of any bargain between the parties, but are merely the manufacturer's opinion or commendation of its products. York and Affinity are registered trademarks of Johnson Controls, Inc., and are used with permission.

Contractor: \_\_\_\_\_ P.O.: \_\_\_\_\_

Engineer: \_\_\_\_\_

Project Name: \_\_\_\_\_ Unit Tag: \_\_\_\_\_

Affinity YDL Series  
Single Capacity  
7 - 30 Tons 60Hz



# Wiring Schematics cont.

## Dual Compressor Aurora Advanced and Premium 208-230/60/3

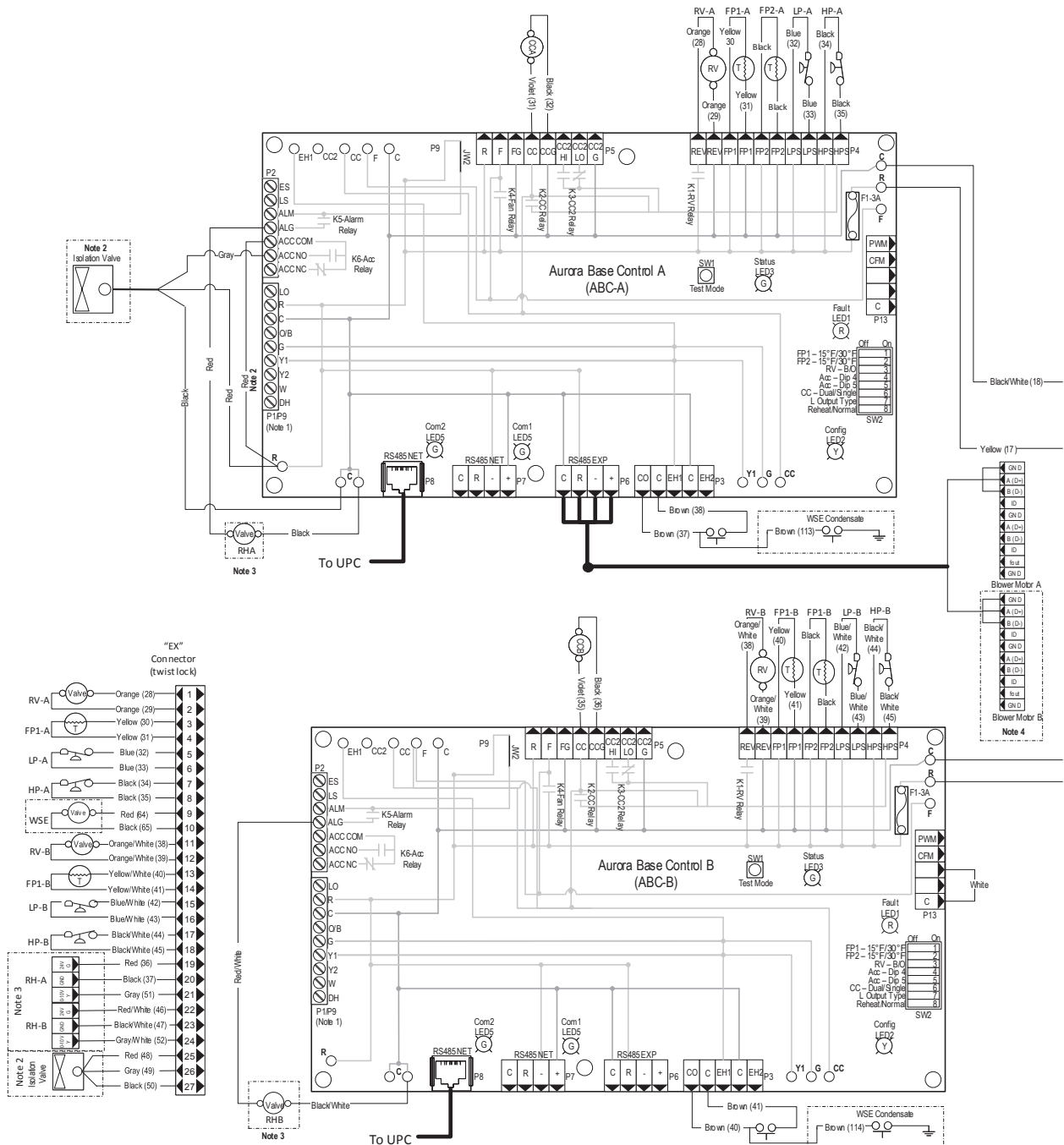

The manufacturer works continually to improve its products. As a result, the design and specifications of each product at the time of order may be changed without notice. Purchaser's approval of this data set signifies that the equipment is acceptable under the provisions of the job specification. Statements and other information contained herein are not express warranties and do not form the basis of any bargain between the parties, but are merely the manufacturer's opinion or commendation of its products. York and Affinity are registered trademarks of Johnson Controls, Inc., and are used with permission.

Contractor: \_\_\_\_\_ P.O.: \_\_\_\_\_

Engineer: \_\_\_\_\_

Project Name: \_\_\_\_\_ Unit Tag: \_\_\_\_\_

Affinity YDL Series  
Single Capacity  
7 - 30 Tons 60Hz



# Wiring Schematics cont.

## Dual Compressor Aurora Advanced and Premium 208-230/60/3

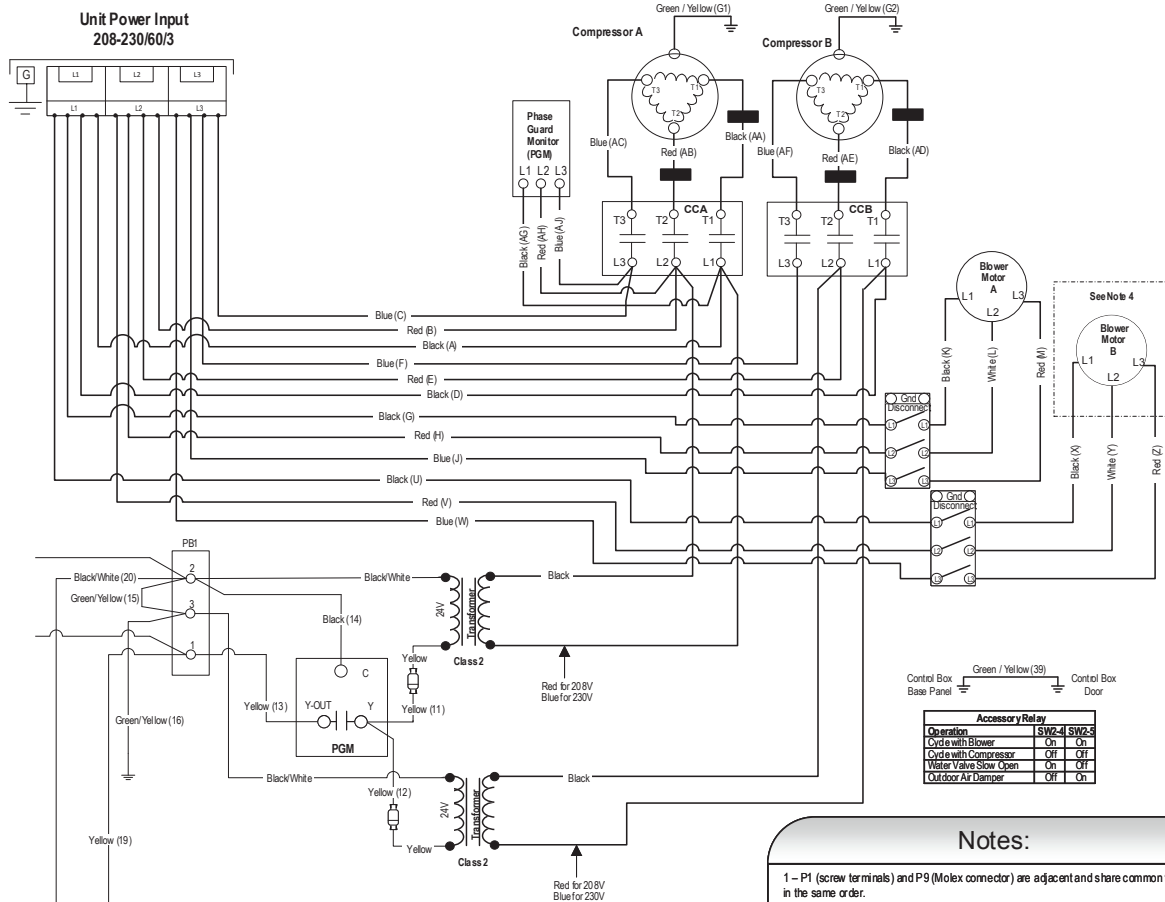

Operation	Accessory Relay	SW2-4	SW2-5
Cycle with Blower	On	On	On
Cycle with Compressor	Off	Off	Off
Water Valve Slow Open	On	Off	Off
Outdoor Air Damper	Off	On	On

**Notes:**

- 1 - P1 (screw terminals) and P9 (Molex connector) are adjacent and share common terminals in the same order.
- 2 - Optional isolation water valve.
- 3 - Optional hot gas reheat.
- 4 - Sizes 240-360 equipped with two blowers.

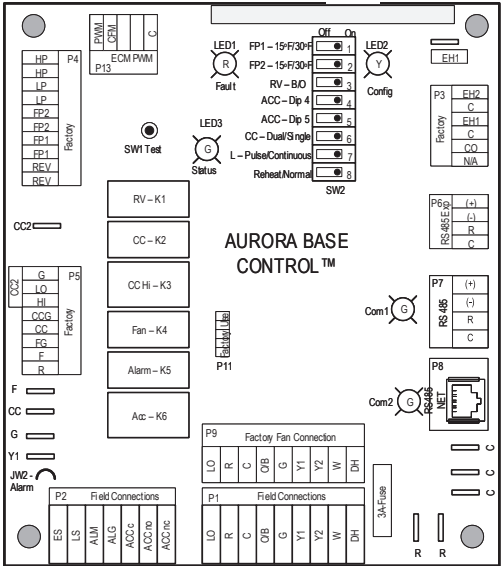

**Legend**

- Factory Low Voltage Wiring
- Factory Line Voltage Wiring
- Field Low Voltage Wiring
- Field Line Voltage Wiring
- Optional Block
- DC Voltage PCB Traces
- Field Zone Sensor Wiring
- Internal Junction
- Quick Connect Terminal
- Field Wiring Lug
- Ground
- Relay Contacts - N.O., N.C.
- Capacitor
- Fuse
- Current Transducer
- Thermistor
- Relay Coil
- Switch - Condensate Overlow
- Switch - High pressure
- Switch - Low pressure
- Polarized connector
- Pin Number Designation on Twist-Lock Connector
- Light Emitting Diode - Green
- Light Emitting Diode - Yellow
- Light Emitting Diode - Red

CCA - Compressor A Contactor  
 CCB - Compressor B Contactor  
 CO - Condensate Overlow Sensor  
 ES - Emergency Shutdown  
 HP1 - High Pressure Switch 1  
 HP2 - High Pressure Switch 2  
 LPI - Low Pressure Switch 1  
 LP2 - Low Pressure Switch 2  
 FP1 - Freeze Protection Sensor 1  
 FP2 - Freeze Protection Sensor 2  
 F1 - Fuse  
 SW1 - Push button  
 SW2 - DIP package 8 position  
 RV1 - Reversing Valve Coil 1  
 RV2 - Reversing Valve Coil 2  
 PGM - Phase Guard Monitor  
 RH - Reheat Valve Coil

The manufacturer works continually to improve its products. As a result, the design and specifications of each product at the time of order may be changed without notice. Purchaser's approval of this data set signifies that the equipment is acceptable under the provisions of the job specification. Statements and other information contained herein are not express warranties and do not form the basis of any bargain between the parties, but are merely the manufacturer's opinion or commendation of its products. York and Affinity are registered trademarks of Johnson Controls, Inc., and are used with permission.

Contractor: \_\_\_\_\_ P.O.: \_\_\_\_\_

Engineer: \_\_\_\_\_

Project Name: \_\_\_\_\_ Unit Tag: \_\_\_\_\_

Affinity YDL Series  
Single Capacity  
7 - 30 Tons 60Hz



# Wiring Schematics cont.

## Dual Compressor Aurora Advanced and Premium 460/60/3

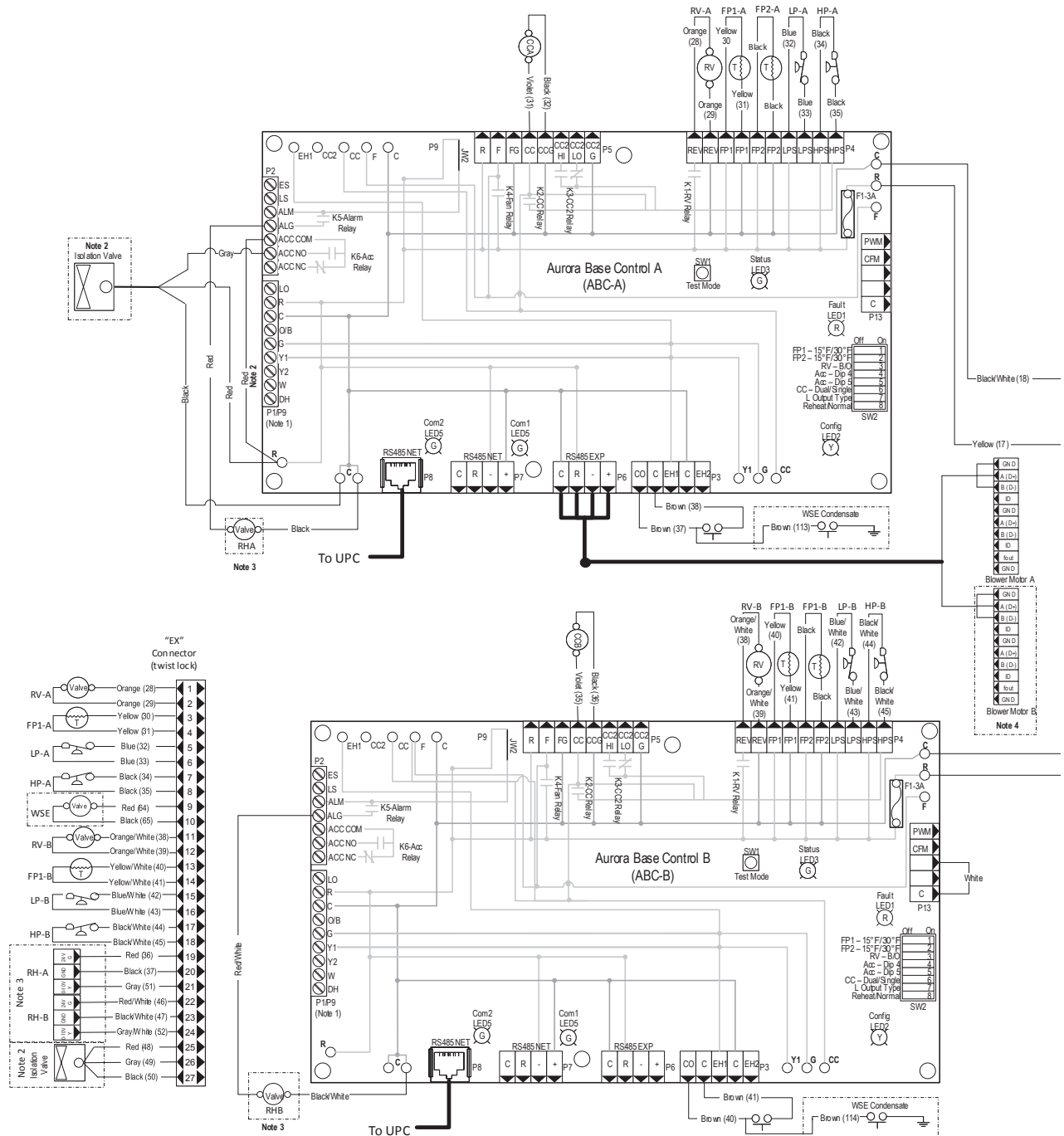

The manufacturer works continually to improve its products. As a result, the design and specifications of each product at the time of order may be changed without notice. Purchaser's approval of this data set signifies that the equipment is acceptable under the provisions of the job specification. Statements and other information contained herein are not express warranties and do not form the basis of any bargain between the parties, but are merely the manufacturer's opinion or commendation of its products. York and Affinity are registered trademarks of Johnson Controls, Inc., and are used with permission.

Contractor: \_\_\_\_\_ P.O.: \_\_\_\_\_  
 Engineer: \_\_\_\_\_  
 Project Name: \_\_\_\_\_ Unit Tag: \_\_\_\_\_

**Affinity YDL Series**  
**Single Capacity**  
**7 - 30 Tons 60Hz**



# Wiring Schematics cont.

## Dual Compressor Aurora Advanced and Premium 460/60/3

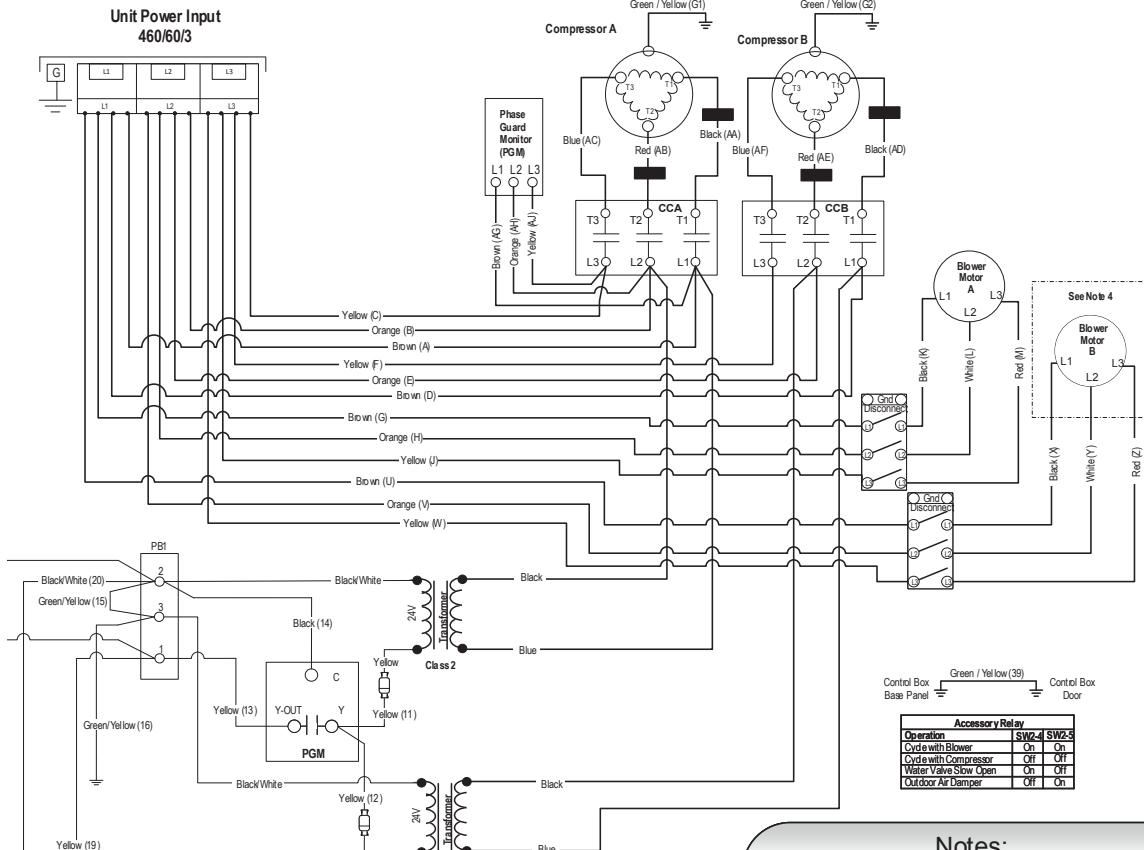

Accessory Relay		
Operator	SW2-4	SW2-8
Cycle with Blower	On	On
Cycle with Compressor	Off	Off
Water Valve Slow Open	On	Off
Outdoor Air Damper	Off	On

**Notes:**

- 1 - P1 (screw terminals) and P9 (Molex connector) are adjacent and share common terminals in the same order.
- 2 - Optional isolation water valve.
- 3 - Optional hot gas reheat.
- 4 - Sizes 240-360 equipped with two blowers.

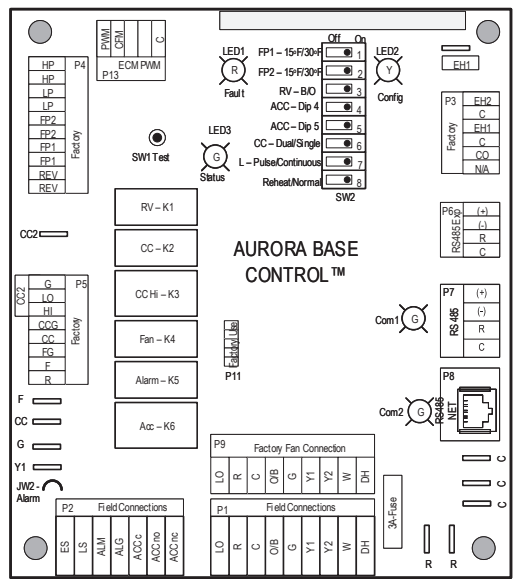

**Legend**

- Factory Low Voltage Wiring
- Factory Line Voltage Wiring
- Field Low Voltage Wiring
- Field Line Voltage Wiring
- Optional Block
- DC Voltage PCB Traces
- Field Zone Sensor Wiring
- Internal Junction
- Qui & Connect Terminal
- Field Wiring Lug
- Ground
- Relay Contacts - NO, N.C.
- Capacitor
- Fuse
- Current Transducer
- Thermistor
- Relay Coil
- Switch - Condensate Overflow
- Switch - High pressure
- Switch - Low pressure
- Polarized connector
- Pin Number Designation on Twist-Lock Connector
- Light Emitting Diode - Green
- Light Emitting Diode - Yellow
- Light Emitting Diode - Red

CCA - Compressor A Contactor  
 CCB - Compressor B Contactor  
 CO - Condensate Overflow Sensor  
 ES - Emergency Shutdown  
 HP1 - High Pressure Switch 1  
 HP2 - High Pressure Switch 2  
 LP1 - Low Pressure Switch 1  
 LP2 - Low Pressure Switch 2  
 FP1 - Freeze Protection Sensor 1  
 FP2 - Freeze Protection Sensor 2  
 F1 - Fuse

SW1 - Push button  
 SW2 - DIP package 8 position  
 RV1 - Reversing Valve Coil 1  
 RV2 - Reversing Valve Coil 2  
 PGM - Phase Guard Monitor  
 RH1 - Reheat Valve Coil

The manufacturer works continually to improve its products. As a result, the design and specifications of each product at the time of order may be changed without notice. Purchaser's approval of this data set signifies that the equipment is acceptable under the provisions of the job specification. Statements and other information contained herein are not express warranties and do not form the basis of any bargain between the parties, but are merely the manufacturer's opinion or commendation of its products. York and Affinity are registered trademarks of Johnson Controls, Inc., and are used with permission.

Contractor: \_\_\_\_\_ P.O.: \_\_\_\_\_

Engineer: \_\_\_\_\_

Project Name: \_\_\_\_\_ Unit Tag: \_\_\_\_\_

**Affinity YDL Series**  
**Single Capacity**  
**7 - 30 Tons 60Hz**



# Wiring Schematics cont.

## Aurora Advanced and Premium Controls Add-on

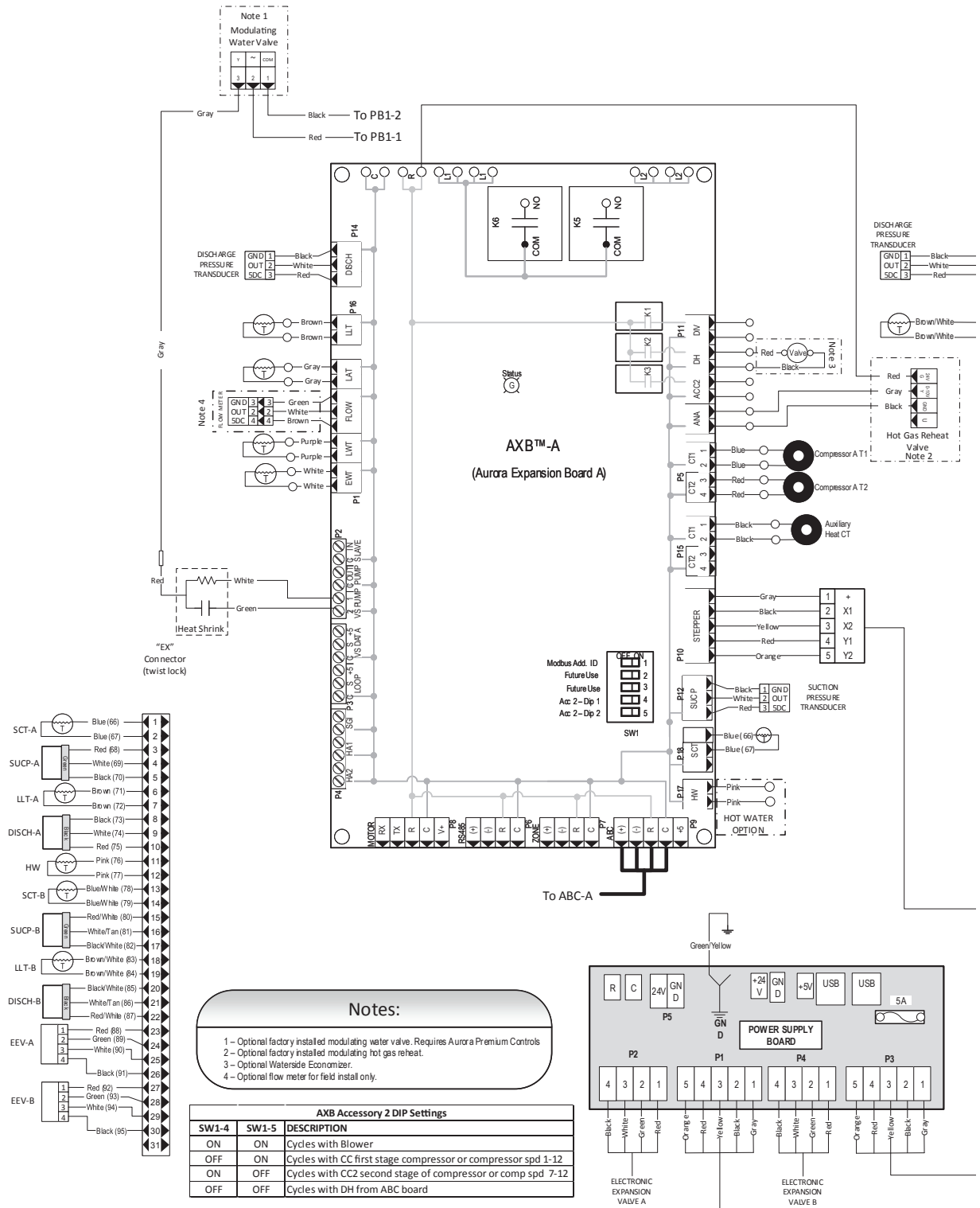

The manufacturer works continually to improve its products. As a result, the design and specifications of each product at the time of order may be changed without notice. Purchaser's approval of this data set signifies that the equipment is acceptable under the provisions of the job specification. Statements and other information contained herein are not express warranties and do not form the basis of any bargain between the parties, but are merely the manufacturer's opinion or commendation of its products. York and Affinity are registered trademarks of Johnson Controls, Inc., and are used with permission.





Contractor: \_\_\_\_\_ P.O.: \_\_\_\_\_

Engineer: \_\_\_\_\_

Project Name: \_\_\_\_\_ Unit Tag: \_\_\_\_\_

Affinity YDL Series  
Single Capacity  
7 - 30 Tons 60Hz



# Wiring Schematics cont.

## Single Compressor 575/60/3

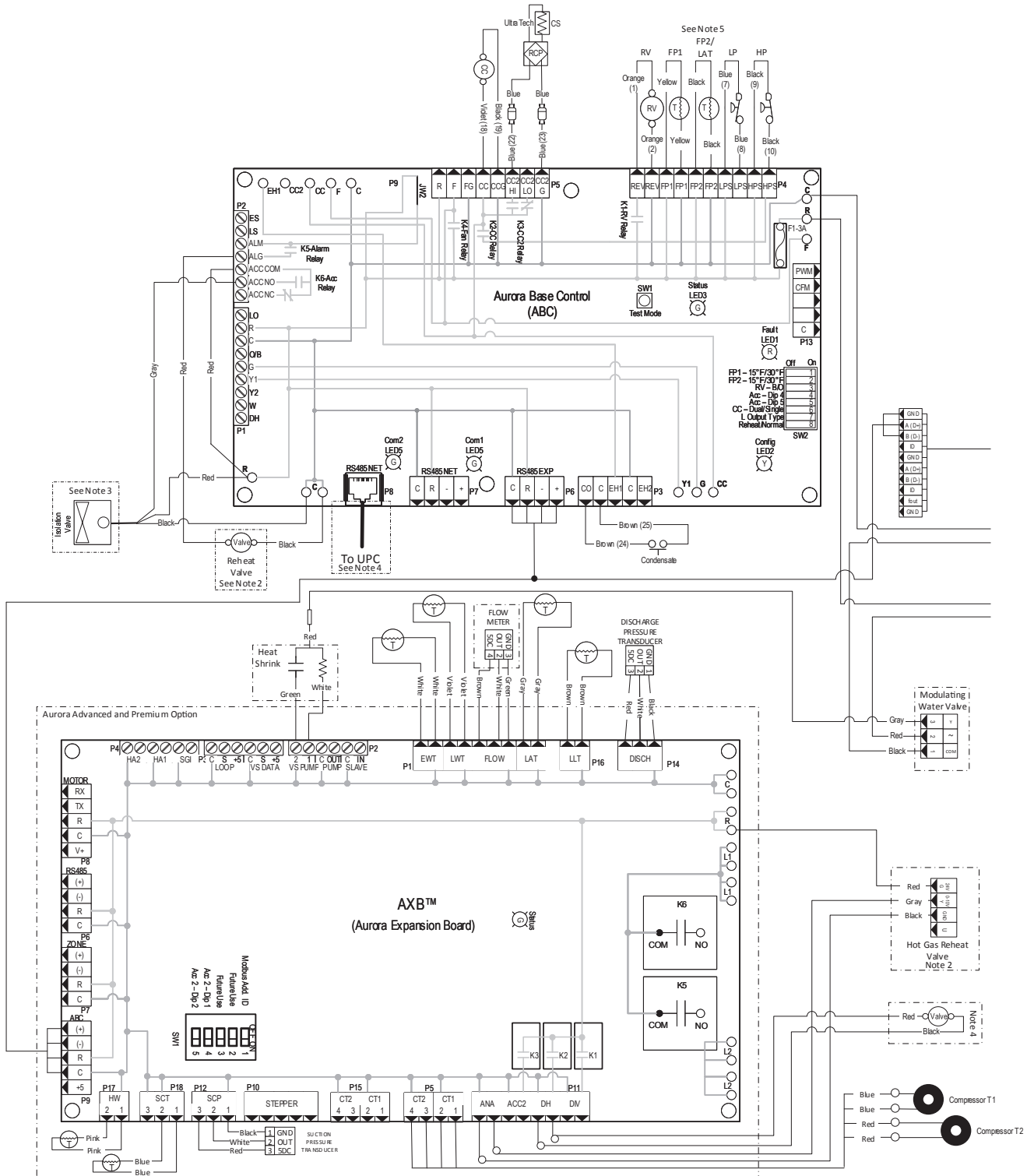

The manufacturer works continually to improve its products. As a result, the design and specifications of each product at the time of order may be changed without notice. Purchaser's approval of this data set signifies that the equipment is acceptable under the provisions of the job specification. Statements and other information contained herein are not express warranties and do not form the basis of any bargain between the parties, but are merely the manufacturer's opinion or commendation of its products. York and Affinity are registered trademarks of Johnson Controls, Inc., and are used with permission.



Contractor: \_\_\_\_\_ P.O.: \_\_\_\_\_  
 Engineer: \_\_\_\_\_  
 Project Name: \_\_\_\_\_ Unit Tag: \_\_\_\_\_

# Wiring Schematics cont.

## Single Compressor 575/60/3

3105300  
03/01/21

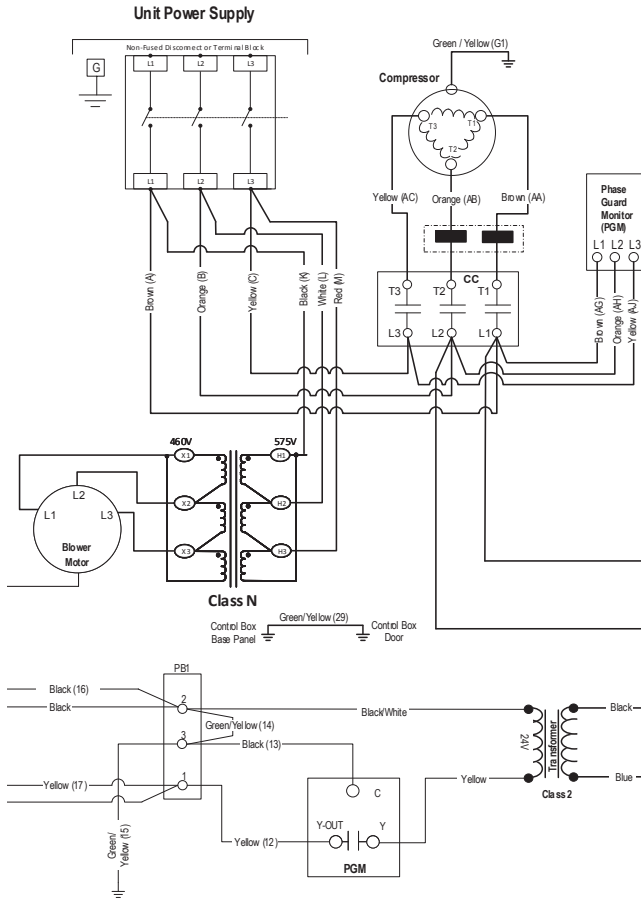

Aurora LED Flash Codes					
Slow Flash	1 second on and 1 second off				
Fast Flash	100 milliseconds on and 100 milliseconds off				
Flash Code	100 milliseconds on and 400 milliseconds off with a 2 second pause before re-pulsing				
Random Start Delay					
Status LED (LED3, Green)	Fast Flash				
Configuration LED (LED2, Yellow)	Fast Flash				
Fault LED (LED1, Red)	Fast Flash				
Status LED (LED3, Green)	Configuration LED (LED2, Yellow)	Fault LED (LED1, Red)			
Normal Mode	ON	No Software Override	Flash EDM Setting	Normal Mode	OFF
Control is Non-Functional	OFF	DIP Switch Override	Slow Flash	Input Fault Lockout	Flash Code 1
Test Mode	Slow Flash	ECM Configure Mode	Fast Flash	High Pressure Lockout	Flash Code 2
Lockout Active	Fast Flash	Reset Configure Mode	Off	Low Pressure Lockout	Flash Code 3
Dehumidification Mode	Flash Code 2			Low Air Coil Limit Lockout - FP2	Flash Code 4
Reserved	Flash Code 3			Low Water Coil Limit Lockout - FP1	Flash Code 5
Reserved	Flash Code 4			Loss of Charge Lockout	Flash Code 6
Load Shed	Flash Code 5			Condensate Over/low Lockout	Flash Code 7
ESD	Flash Code 6			Over/Under Voltage Shutdown	Flash Code 8
Reserved	Flash Code 7			Reserved	Flash Code 9
				Compressor Monitor Lockout	Flash Code 10
				Air/Water Coil Limit Sensor Error	Flash Code 11

Accessory Relay		
Operation	SW2-4	SW2-5
Cycle with Blower	On	On
Cycle with Compressor	Off	Off
Water Valve Slow Open	On	Off
Outdoor Air Damper	Off	On

Aurora Timing Events		
Event	Normal Mode	Test Mode
Random Start Delay	5 to 80 seconds	1 second
Compressor On Delay	5 seconds	< 1 second
Compressor Minimum On Time	2 minutes	5 seconds
Compressor Short Cycle Delay	4 minutes	15 seconds
Blower Off Delay	30 seconds	2 seconds
Fault Recognition Delay - High Pressure	Less than 1 second	Less than 1 second
Start-Up Bypass - Low Pressure	2 minutes	30 seconds
Fault Recognition Delay - Low Pressure	30 seconds	30 seconds
Start-Up Bypass - Low Water/Air Coil Limit	2 minutes	30 seconds
Fault Recognition Delay - Low Water/Air Coil Limit	30 seconds	30 seconds
Fault Recognition Delay - Condensate Overflow	30 seconds	30 seconds
Thermostat Call Reception Time	2 seconds	2 seconds
Auxiliary Heat Staging Delay	5 minutes	20 seconds
Emergency Heat Staging Delay	2 minutes	7.5 seconds
Water Valve Slow Open Delay	90 seconds	90 seconds
Reheat Delay	30 seconds	30 seconds

**Notes:**

- 1 - P1 (screw terminals) and P9 (Molex connector) are adjacent and share common terminals in the same order.
- 2 - Optional factory installed hot gas reheat.
- 3 - Optional factory installed internal isolation valve.
- 4 - See supplemental schematic for AXB and/or LPC connections.
- 5 - LAT location with Aurora Base Controls, FP2 with Aurora Advanced and Premium Controls.

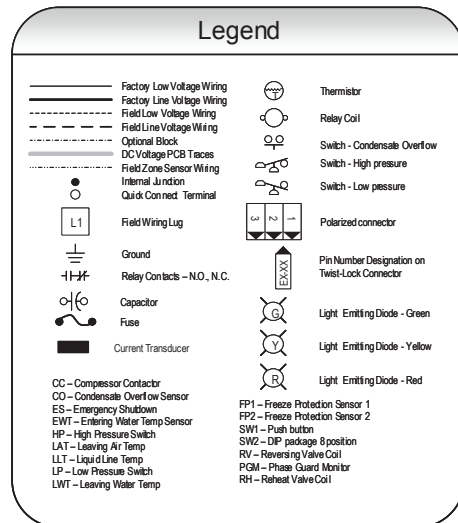
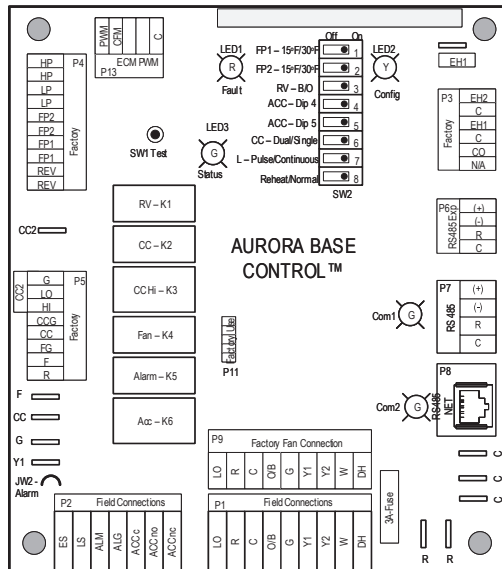

The manufacturer works continually to improve its products. As a result, the design and specifications of each product at the time of order may be changed without notice. Purchaser's approval of this data set signifies that the equipment is acceptable under the provisions of the job specification. Statements and other information contained herein are not express warranties and do not form the basis of any bargain between the parties, but are merely the manufacturer's opinion or commendation of its products. York and Affinity are registered trademarks of Johnson Controls, Inc., and are used with permission.

Contractor: \_\_\_\_\_ P.O.: \_\_\_\_\_

Engineer: \_\_\_\_\_

Project Name: \_\_\_\_\_ Unit Tag: \_\_\_\_\_

**Affinity YDL Series**  
**Single Capacity**  
**7 - 30 Tons 60Hz**



# Wiring Schematics cont.

## Dual Compressor Aurora Base 575/60/3

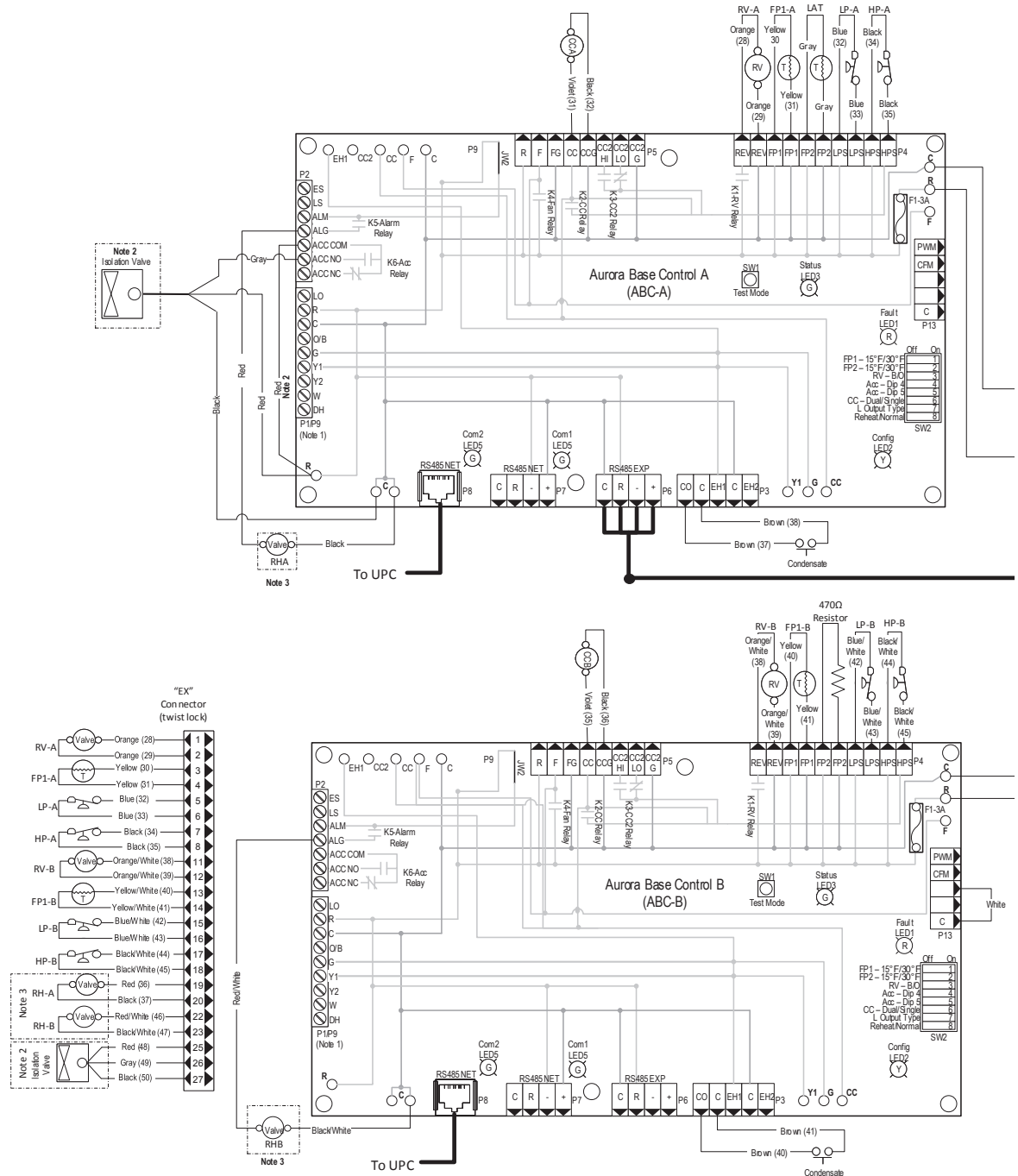

The manufacturer works continually to improve its products. As a result, the design and specifications of each product at the time of order may be changed without notice. Purchaser's approval of this data set signifies that the equipment is acceptable under the provisions of the job specification. Statements and other information contained herein are not express warranties and do not form the basis of any bargain between the parties, but are merely the manufacturer's opinion or commendation of its products. York and Affinity are registered trademarks of Johnson Controls, Inc., and are used with permission.

Contractor: \_\_\_\_\_ P.O.: \_\_\_\_\_  
 Engineer: \_\_\_\_\_  
 Project Name: \_\_\_\_\_ Unit Tag: \_\_\_\_\_

**Affinity YDL Series**  
**Single Capacity**  
**7 - 30 Tons 60Hz**



# Wiring Schematics cont.

## Dual Compressor Aurora Base 575/60/3

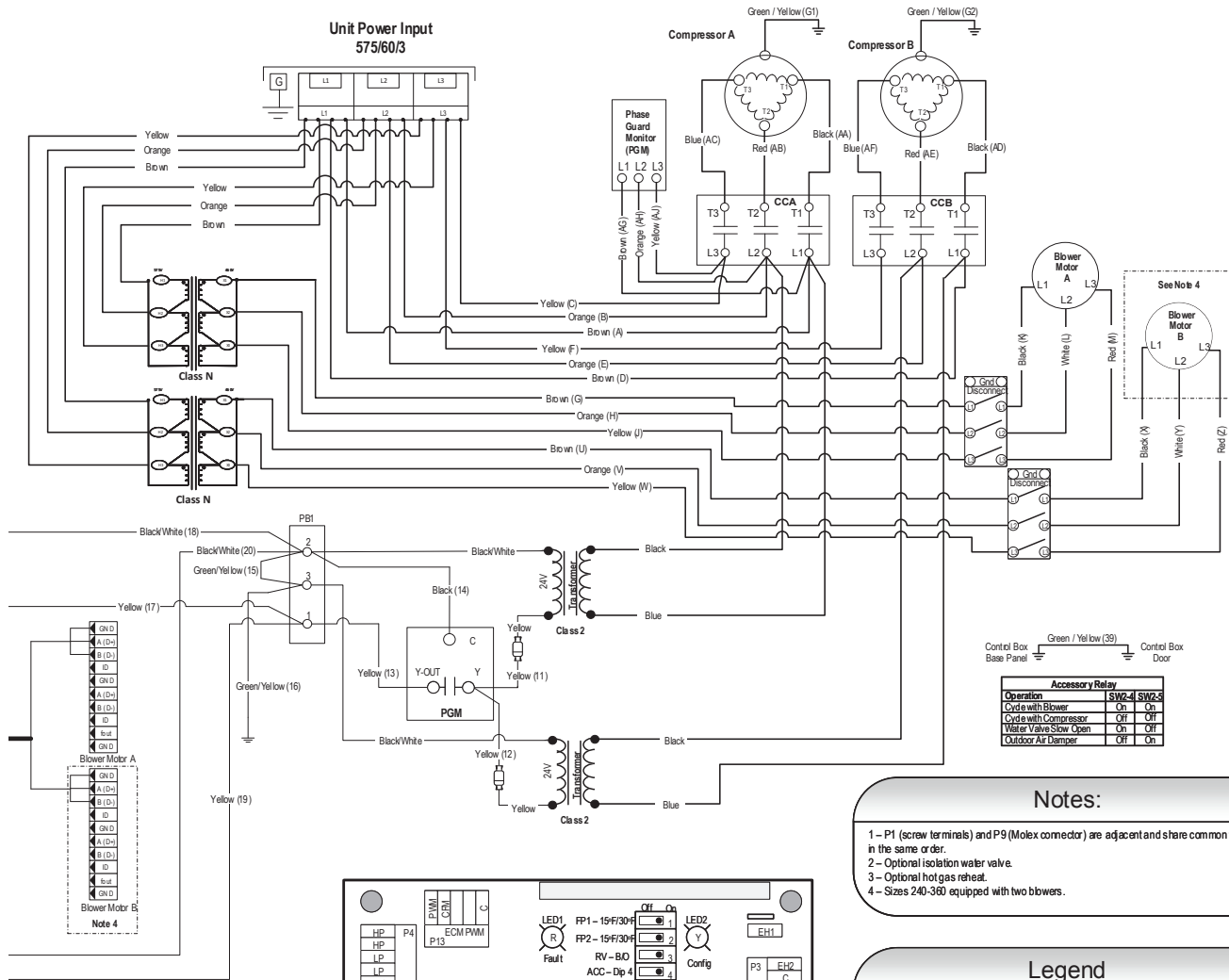

Accessory Relay			
Operation	SW1	SW2	SW2.5
Cycle with Blower	On	On	
Cycle with Compressor	Off	Off	
Water Valve Slow Open	On	Off	
Outdoor Air Damper	Off	On	

**Notes:**

- 1 - P1 (screw terminals) and P9 (Molex connector) are adjacent and share common terminals in the same order.
- 2 - Optional isolation water valve.
- 3 - Optional hot gas reheat.
- 4 - Sizes 240-360 equipped with two blowers.

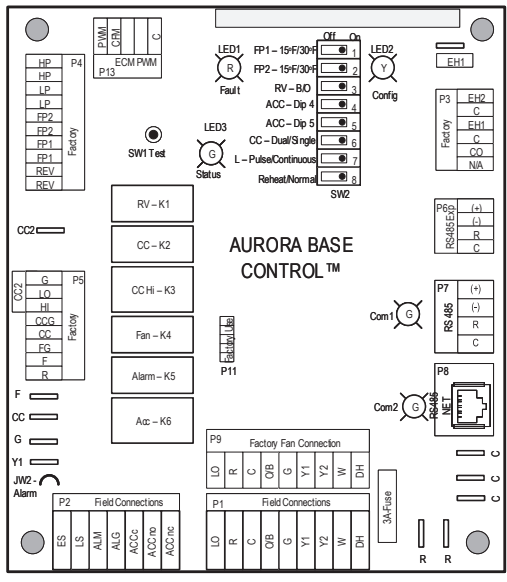

**Legend**

- Factory Low Voltage Wiring
- Factory Line Voltage Wiring
- Field Low Voltage Wiring
- Field Line Voltage Wiring
- Optional Block
- DC Voltage PCB Traces
- Field Zone Sensor Wiring
- Internal Junction
- Quick Connect Terminal
- Field Wiring Lug
- Ground
- Relay Contacts - N.O., N.C.
- Capacitor
- Fuse
- Thermistor
- Relay Coil
- Switch - Condensate Overflow
- Switch - High pressure
- Switch - Low pressure
- Polarized connector
- Pin Number Designation on Twist-Lock Connector
- Light Emitting Diode - Green
- Light Emitting Diode - Yellow
- Light Emitting Diode - Red

CCA - Compressor A Contactor  
 CCB - Compressor B Contactor  
 CO - Condensate Overflow Sensor  
 ES - Emergency Shutdown  
 HP1 - High Pressure Switch 1  
 HP2 - High Pressure Switch 2  
 LP1 - Low Pressure Switch 1  
 LP2 - Low Pressure Switch 2  
 FP1 - Freeze Protection Sensor 1  
 FP2 - Freeze Protection Sensor 2  
 F1 - Fuse

SW1 - Push button  
 SW2 - DIP package 8 position  
 RV1 - Reversing Valve Coil 1  
 RV2 - Reversing Valve Coil 2  
 PGM - Phase Guard Monitor  
 RH - Reheat Valve Coil

The manufacturer works continually to improve its products. As a result, the design and specifications of each product at the time of order may be changed without notice. Purchaser's approval of this data set signifies that the equipment is acceptable under the provisions of the job specification. Statements and other information contained herein are not express warranties and do not form the basis of any bargain between the parties, but are merely the manufacturer's opinion or commendation of its products. York and Affinity are registered trademarks of Johnson Controls, Inc., and are used with permission.

Contractor: \_\_\_\_\_ P.O.: \_\_\_\_\_

Engineer: \_\_\_\_\_

Project Name: \_\_\_\_\_ Unit Tag: \_\_\_\_\_

Affinity YDL Series  
Single Capacity  
7 - 30 Tons 60Hz



# Wiring Schematics cont.

## Dual Compressor Aurora Advanced and Premium 575/60/3

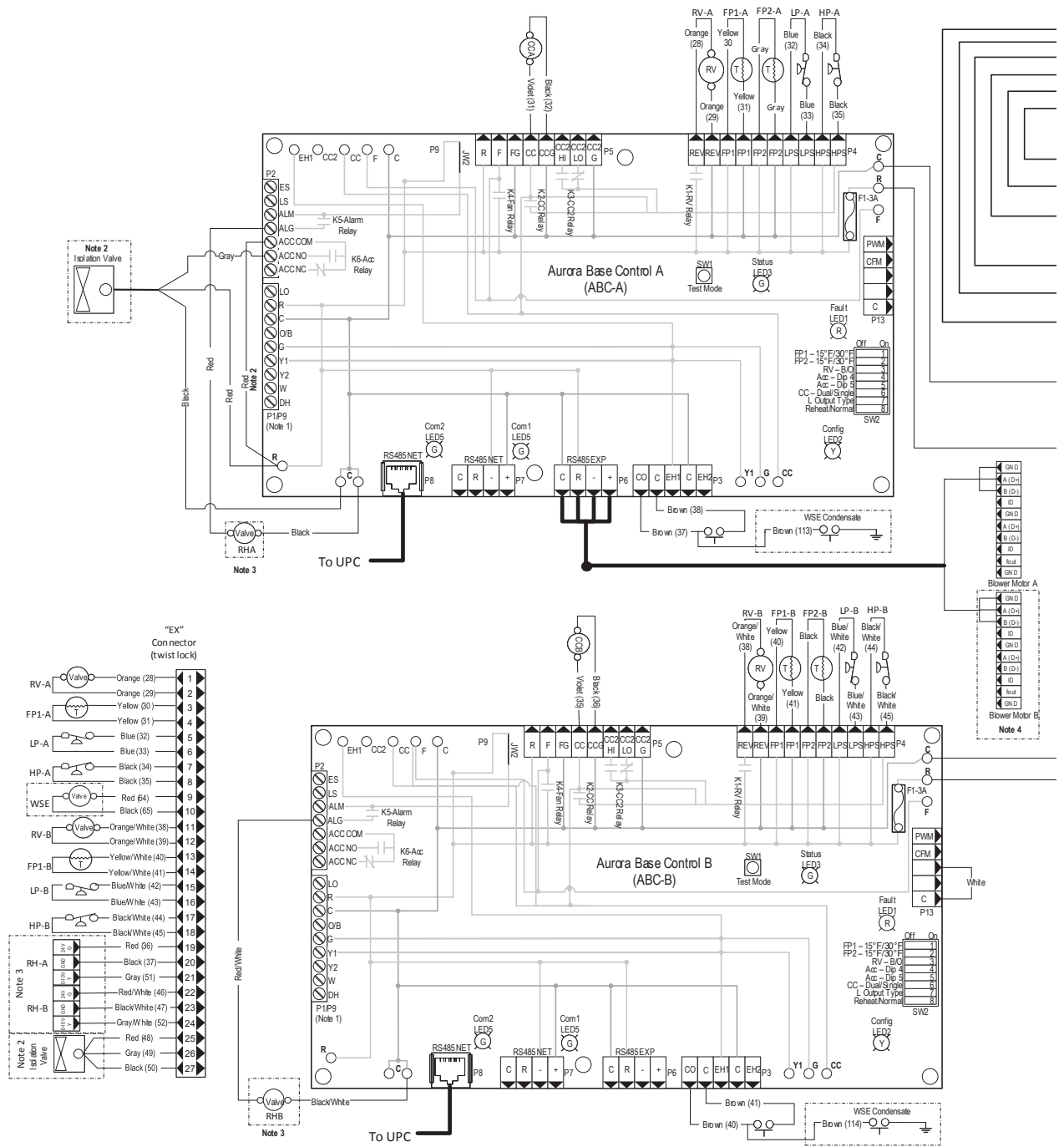

The manufacturer works continually to improve its products. As a result, the design and specifications of each product at the time of order may be changed without notice. Purchaser's approval of this data set signifies that the equipment is acceptable under the provisions of the job specification. Statements and other information contained herein are not express warranties and do not form the basis of any bargain between the parties, but are merely the manufacturer's opinion or commendation of its products. York and Affinity are registered trademarks of Johnson Controls, Inc., and are used with permission.

Contractor: \_\_\_\_\_ P.O.: \_\_\_\_\_  
 Engineer: \_\_\_\_\_  
 Project Name: \_\_\_\_\_ Unit Tag: \_\_\_\_\_

**Affinity YDL Series**  
**Single Capacity**  
**7 - 30 Tons 60Hz**



# Wiring Schematics cont.

## Dual Compressor Aurora Advanced and Premium 575/60/3

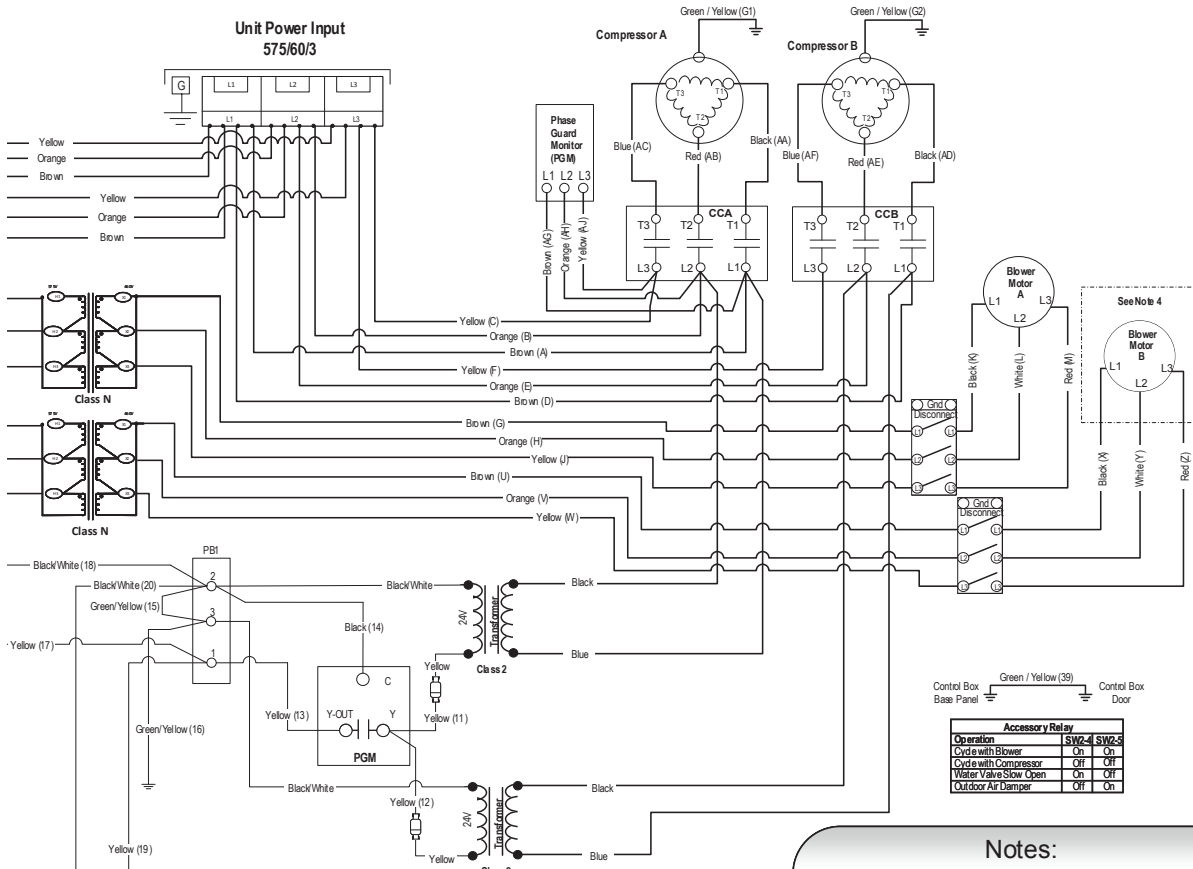

Accessory Relay		
Operation	SW2-4	SW2-5
Cycle with Blower	On	On
Cycle with Compressor	Off	Off
Water Valve Slow Open	On	Off
Outdoor Air Damper	Off	On

### Notes:

- 1 - P1 (screw terminals) and P9 (Molex connector) are adjacent and share common terminals in the same order.
- 2 - Optional isolation water valve.
- 3 - Optional hot gas reheat.
- 4 - Sizes 240-380 equipped with two blowers.

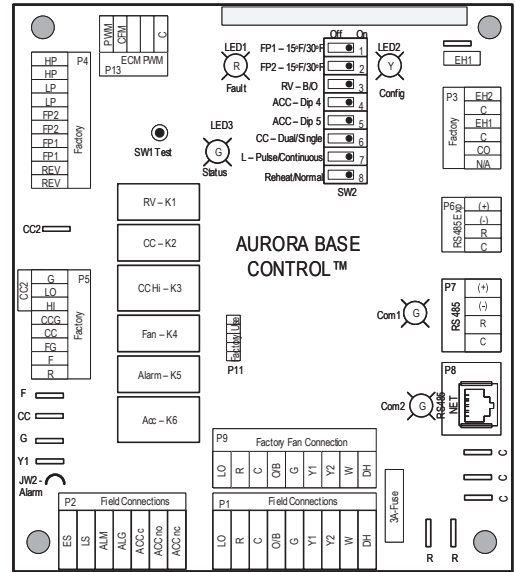

### Legend

- Factory Low Voltage Wiring
- Factory Line Voltage Wiring
- Field Low Voltage Wiring
- Field Line Voltage Wiring
- Optional Block
- DC Voltage PCB Traces
- Field Zone Sensor Wiring
- Internal Junction
- Quick Connect Terminal
- Field Wiring Lug
- Ground
- Relay Contacts - N.O., N.C.
- Capacitor
- Fuse
- Current Transducer
- Thermistor
- Relay Coil
- Switch - Condensate Overflow
- Switch - High pressure
- Switch - Low pressure
- Polarized connector
- Pin Number Designation on Twist-Lock Connector
- Light Emitting Diode - Green
- Light Emitting Diode - Yellow
- Light Emitting Diode - Red

The manufacturer works continually to improve its products. As a result, the design and specifications of each product at the time of order may be changed without notice. Purchaser's approval of this data set signifies that the equipment is acceptable under the provisions of the job specification. Statements and other information contained herein are not express warranties and do not form the basis of any bargain between the parties, but are merely the manufacturer's opinion or commendation of its products. York and Affinity are registered trademarks of Johnson Controls, Inc., and are used with permission.



Contractor: \_\_\_\_\_ P.O.: \_\_\_\_\_

Engineer: \_\_\_\_\_

Project Name: \_\_\_\_\_ Unit Tag: \_\_\_\_\_

## Engineering Guide Specifications

### General

Furnish and install WaterFurnace Water Source Heat Pumps as indicated on the plans. Equipment shall be completely assembled, piped and internally wired. Capacities and characteristics as listed in the schedule and the specifications that follow. The reverse cycle heating/cooling units shall be either suspended type with horizontal air inlet and discharge or floor mounted type with horizontal air inlet and vertical upflow air discharge. Units shall be AHRI/ISO 13256-1 certified and listed by a nationally recognized safety-testing laboratory or agency, such as UL Testing Laboratory. Each unit shall be computer run-tested at the factory with conditioned water and operation verified to catalog data. Each unit shall be mounted on a pallet and shipped in a corrugated box or stretch-wrapped. The units shall be designed to operate with entering liquid temperature between 20°F and 120°F [-6.7°C and 48.9°C].

### Casing and Cabinet

One (horizontal) to two (vertical) blower and two compressor compartment access panels shall be 'lift-out' removable with supply and return ductwork in place.

A duct collar shall be provided on the supply air opening. Standard size 2 in. [5.1 cm] MERV 4 filters shall be provided with each unit. Units shall have a return air filter rack that is field convertible from 1 in. [2.54 cm] to 2 in. [5.1 cm]. The upflow vertical units shall have a removable insulated divider panel between the air handling section and the compressor section to minimize the transmission of compressor noise and to permit operational service testing without air bypass. Vertical units shall be supplied with left or right horizontal air inlet and top vertical air discharge. Horizontal units shall be supplied with left or right air inlet and side or end air discharge.

**Option: AlpinePure MERV 13 Filter** - A 2 in. thick [51 mm] MERV 13 filter can help fulfill a credit under the LEED Rating System. Its low initial resistance promotes low energy consumption (0.21 in. w.g. @ 300 fpm) and provides nearly twice the life of a standard filter (300 fpm vs. standard 500 fpm application).

**Option: A Super Quiet Sound package** shall include multi-density full coverage compressor blanket.

**Option: A field mounted low pressure drop (high Cv) water solenoid valve** shall be factory installed for use in variable speed pumping applications.

**Option: An internally mounted vortex shedding flow meter** that uses MEMS technology with corrosion-resistant coating on the electronic chip to directly measure fluid flow. The sensor is in direct contact with the fluid and does not require any moving parts. Flow measurement is reportable through the BAS.

**Option: An internally mounted 2-way modulating solenoid valve** shall be factory installed and modulated by the Advanced Aurora Controls platform. Modulating percentage range is adjustable through the Aurora and the valve position is tied to compressor speed.

Compressors shall be high-efficiency permanent magnet motor, scroll type designed for variable capacity heat pump duty and mounted on vibration isolators. Compressors are matched to high-efficiency variable frequency drive (VFD) that communicate via ModBus to the Advanced Aurora Controls platform.

With vertical top/side discharge units, the condensate connection shall be a 3/4 in. [19.1 mm] PVC FPT fitting with internally-trapped hose that can be routed to front or side corner post locations. On horizontal and vertical bottom-flow units, a stainless steel 7/8" tube connects to a 3/4" MPT push to connect fitting. These units must be externally trapped.

### Refrigerant Circuit

All units shall utilize the non-ozone depleting and low global warming potential refrigerant R-410A. All units shall contain a sealed refrigerant circuit including a hermetic motor-compressor, bidirectional electronic expansion valve, finned tube air-to-refrigerant heat exchanger, reversing valve, coaxial heat exchanger, and service ports.

The cabinet shall be fabricated from heavy-gauge galvanized steel and finished with optional corrosion-resistant powder coating. This corrosion protection system shall meet the stringent 1000 hour salt spray test per ASTM B117. The interior shall be insulated with 1/2 in. thick, multi-density, cleanable aluminum foil coated glass fiber with edges sealed or tucked under flanges to prevent the introduction of glass fibers into the discharge air. Standard cabinet panel insulation must meet NFPA 90A requirements, air erosion and mold growth limits of UL-181, stringent fungal resistance test per ASTM-C1071 and ASTM G21, and shall meet zero level bacteria growth per ASTM G22. Unit insulation must meet these stringent requirements or unit(s) will not be accepted.



Contractor: \_\_\_\_\_ P.O.: \_\_\_\_\_

Engineer: \_\_\_\_\_

Project Name: \_\_\_\_\_ Unit Tag: \_\_\_\_\_

## Engineering Guide Specifications cont.

### *Option: AlumiSeal electro-coated air coil.*

The coaxial water-to-refrigerant heat exchanger shall be designed for low water pressure drop and constructed of a convoluted copper (cupronickel option) inner tube and a steel outer tube. Refrigerant to air heat exchangers shall utilize enhanced corrugated lanced aluminum fins and rifled aluminum tube construction rated to withstand 600 psig (4135 kPa) refrigerant working pressure. Refrigerant to water heat exchangers shall be of copper inner water tube and steel refrigerant outer tube design, rated to withstand 600 psig (4135 kPa) working refrigerant pressure and 450 psig (3101 kPa) working water pressure. The thermostatic expansion valve shall provide proper superheat over the entire liquid temperature range with minimal "hunting." The valve shall operate bidirectionally without the use of check valves.

### *Option: ThermaShield coated water-to-refrigerant heat exchanger, water lines and refrigerant suction lines*

shall be insulated to prevent condensation at low liquid temperatures below 50°F.

### *Option: AlpinePure hot gas bypass*

## Blower Motor and Assembly

Supply fan shall be of single width, single inlet backward curved airfoil centrifugal fan design often referred to as a 'plenum fan'. The fan wheel shall be of Class II construction with aluminum fan blades that are continuously welded to the hub plate and end rim. The supply fan shall be a direct drive fan mounted to the motor shaft. Fan assembly shall be a slide out assembly for servicing and maintenance. All fan assemblies shall be statically and dynamically balanced at the factory. The fan motor shall be a high efficiency totally enclosed electronically commutated (EC) motor that is speed controlled by the Aurora controller. The motor shall include thermal overload protection and protect the motor in the case of excessive motor temperatures. The variable speed EC fan motor shall be soft starting and shall provide 12 cfm settings. The fan shall not operate in a state of surge at any point within the modulation range.

## Electrical

A control box shall be located within the unit compressor compartment and shall contain a 75VA transformer, 24 volt activated, 2 pole compressor contactor, terminal block for thermostat wiring and solid-state controller for complete unit operation. Electromechanical operation WILL NOT be accepted. Units shall be name-plated for use with time delay fuses or HACR circuit breakers. Unit controls shall be 24 volt and provide heating or cooling as required by the remote thermostat/sensor.

An Aurora microprocessor-based controller that interfaces with a multi-stage electronic thermostat to monitor and control unit operation shall be provided. The control shall provide operational sequencing, blower speed control, high and low pressure switch monitoring, freeze detection, condensate overflow sensing, lockout mode control, LED status and fault indicators, fault memory, field selectable options and accessory output. The control shall provide fault retry three times before locking out to limit nuisance trips.

A detachable terminal block with screw terminals will be provided for field control wiring. All units shall have knockouts for entrance of low and line voltage wiring. The blower motor and control box shall be harness plug wired for easy removal.





Contractor: \_\_\_\_\_ P.O.: \_\_\_\_\_

Engineer: \_\_\_\_\_

Project Name: \_\_\_\_\_ Unit Tag: \_\_\_\_\_

## Engineering Guide Specifications cont.

### Piping

Supply and return water connections shall be FPT copper fittings fixed to the corner post, which eliminate the need for backup pipe wrenches.

With vertical units, the condensate connection shall be a 3/4 in. [19.1 mm] PVC FPT fitting with internally-trapped hose that can be routed to front or side corner post locations.

In horizontal and bottom flow units, the condensate connection shall be 7/8 in. stainless steel tube that connects to unit provided 3/4 in. MPT push to connect.

### Accessories

#### Thermostat (field-installed)

A communicating auto-changeover electronic digital thermostat shall be provided. The thermostat shall offer variable speed heating and cooling staging with precise temperature control. An OFF-HEAT-AUTO-COOL-EMERG system switch, OFF-AUTO-INTERMITTENT blower switch, and indicating display shall be provided. The thermostat shall display in °F or °C. The thermostat shall provide real time energy consumption data of the unit.

#### Color Touchscreen Thermostat (field-installed)

A color touchscreen communicating auto-changeover electronic digital thermostat shall be provided. The thermostat shall offer variable speed heating and cooling staging with precise temperature control. An OFF-HEAT-AUTO-COOL-EMERG system switch, OFF-AUTO-INTERMITTENT blower switch, and indicating display shall be provided. The thermostat shall display in °F or °C. The thermostat shall provide real time and historical energy consumption data of the unit.

#### Hose Kits – Ball Valves (field-installed)

A flexible steel braid hose featuring Kevlar® reinforced EPDM core with ANSI 302/304 stainless steel outer braid and fire rated materials per ASTM E 84-00 (NFPA 255, ANSI/UL 723 & UBC 8-1). Ball valve at one end; swivel connector with adapter at the other end (swivel to adapter connection via fiber or EPDM gasket). Swivel connection provides union between heat pump and piping system. The hoses feature brass fittings, stainless steel ferrules. A full port ball valve shall be provided with integral P/T (pressure/temperature) port on supply hose.

#### Specifications:

- Temperature range of 35°F [2°C] to 180°F [82°C].
- Max. working pressure of 400 psi [2757 kPa] for 1/2 in. and 3/4 in. hose kits; max. working pressure of 350 psi [kPa] for 1 in. and 1-1/4 in. hose kits.

#### Hose Kits – Automatic Balancing and Ball Valves (field-installed)

A flexible steel braid hose featuring Kevlar® reinforced EPDM core with ANSI 302/304 stainless steel outer braid and fire rated materials per ASTM E 84-00 (NFPA 255, ANSI/UL 723 & UBC 8-1). Ball valve at one end; swivel connector with adapter at the other end (swivel to adapter connection via fiber or EPDM gasket). Swivel connection provides union between heat pump and piping system. The hoses feature brass fittings, stainless steel ferrules. A full port ball valve shall be provided with integral P/T (pressure/temperature) port on supply hose and automatic balancing valve with integral P/T ports and full port ball valve on return hose.

#### Specifications:

- Temperature range of 35°F [2°C] to 180°F [82°C]
- Max. working pressure of 400 psi [2757 kPa] for 1/2 in. and 3/4 in. hose kits; max. working pressure of 350 psi [2413 kPa] for 1 in. and 1-1/4 in. hose kits
- Minimum burst pressure of four times working pressure

#### Hose Kits – Automatic Balancing and Ball Valves with ‘Y’ strainer (field-installed)

A flexible steel braid hose featuring Kevlar® reinforced EPDM core with ANSI 302/304 stainless steel outer braid and fire rated materials per ASTM E 84-00 (NFPA 255, ANSI/UL 723 & UBC 8-1). Ball valve at one end; swivel connector with adapter at the other end (swivel to adapter connection via fiber or EPDM gasket). Swivel connection provides union between heat pump and piping system. The hoses feature brass fittings, stainless steel ferrules. A “y” strainer is provided on one end for fluid straining and integral “blowdown” valve. A full port ball valve shall be provided with integral P/T (pressure/temperature) port on supply hose and automatic balancing valve with integral P/T ports and full port ball valve on return hose.

#### Specifications:

- Temperature range of 35°F [2°C] to 180°F [82°C]
- Max. working pressure of 400 psi [2756 kPa] for 1/2 in. and 3/4 in. hose kits; max. working pressure of 350 psi [2413 kPa] for 1 in. and 1-1/4 in. hose kits
- Minimum burst pressure of four times working pressure

Contractor: \_\_\_\_\_ P.O.: \_\_\_\_\_

Engineer: \_\_\_\_\_

Project Name: \_\_\_\_\_ Unit Tag: \_\_\_\_\_



## Revision Guide

---

Pages:	Description:	Date:	By:
All	Document Creation	15 July 2021	JM