



***SUBMITTAL SET***

**AFFINITY INDOOR SPLIT  
GEOTHERMAL HEAT PUMPS  
SINGLE AND DUAL CAPACITY**

**MODELS:**

**YAZS022 - 070**

**(2 THRU 6 NOMINAL TONS)**

**YAZT026 - 072**

**(2 THRU 6 NOMINAL TONS)**



Due to continuous product improvement, specifications are subject to change without notice.

Visit us on the web at [www.york-geothermal.com](http://www.york-geothermal.com)

Additional rating information can found at [www.ahridirectory.org](http://www.ahridirectory.org)

**FOR DISTRIBUTION USE ONLY - NOT TO BE USED AT POINT OF RETAIL SALE**

Contractor: \_\_\_\_\_ P.O.: \_\_\_\_\_

Engineer: \_\_\_\_\_

Project Name: \_\_\_\_\_ Unit Tag: \_\_\_\_\_

**Affinity Single & Dual Capacity  
Indoor Split Series  
2 - 6 Tons 60Hz**



## Model Nomenclature

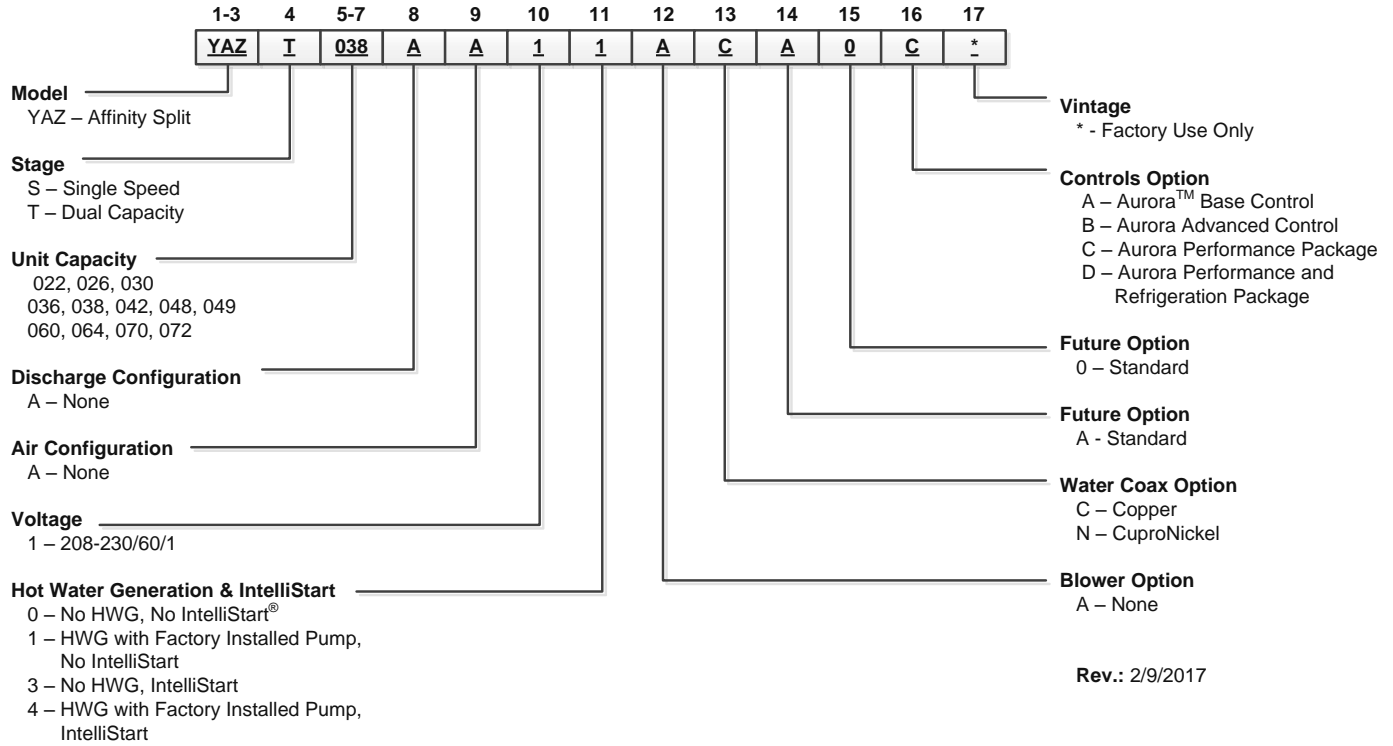

The manufacturer works continually to improve its products. As a result, the design and specifications of each product at the time of order may be changed without notice. Purchaser's approval of this data set signifies that the equipment is acceptable under the provisions of the job specification. Statements and other information contained herein are not express warranties and do not form the basis of any bargain between the parties, but are merely the manufacturer's opinion or commendation of its products. York and Affinity are registered trademarks of Johnson Controls, Inc., and are used with permission.

Contractor: \_\_\_\_\_ P.O.: \_\_\_\_\_

Engineer: \_\_\_\_\_

Project Name: \_\_\_\_\_ Unit Tag: \_\_\_\_\_

**Affinity Single & Dual Capacity  
Indoor Split Series  
2 - 6 Tons 60Hz**



## AHRI Data

Model	SAH Air Handler Model	Capacity Modulation	Flow Rate		Water Loop Heat Pump				Ground Water Heat Pump				Ground Loop Heat Pump			
					Cooling Brine EWT 86°F		Heating Brine EWT 68°F		Cooling EWT 59°F		Heating EWT 50°F		Cooling Brine Full Load 77°F Part Load 68°F		Heating Brine Full Load 32°F Part Load 41°F	
			gpm	cfm	Capacity Btuh	EER Btuh/W	Capacity Btuh	COP	Capacity Btuh	EER Btuh/W	Capacity Btuh	COP	Capacity Btuh	EER Btuh/W	Capacity Btuh	COP
026	026	Full	8	850	22,500	15.0	28,100	5.0	25,800	23.0	23,300	4.6	23,400	17.5	18,400	3.7
		Part	7	750	17,400	17.0	21,200	6.0	20,000	29.0	17,400	5.0	19,200	24.5	15,500	4.3
038	036	Full	9	1200	34,400	16.3	41,600	5.2	38,200	24.2	35,100	4.7	36,000	19.0	27,900	4.0
		Part	8	800	24,600	18.3	30,000	5.4	28,000	32.5	25,100	4.7	27,000	27.0	22,500	4.2
049	048	Full	12	1500	43,200	15.4	56,300	5.1	51,000	24.2	47,100	4.6	46,300	18.0	37,700	3.9
		Part	11	1300	32,500	17.0	41,600	5.9	39,400	31.0	34,000	4.9	37,500	25.8	30,000	4.4
064	060	Full	16	1800	54,800	15.0	66,900	4.8	63,200	22.5	56,000	4.4	57,400	17.0	45,200	3.7
		Part	14	1500	40,900	16.5	48,900	5.4	48,500	29.0	40,100	4.6	46,300	24.5	35,600	4.1
072	066	Full	18	2000	60,400	14.0	81,000	4.5	70,000	22.0	67,500	4.1	62,800	16.0	53,500	3.5
		Part	16	1600	46,600	15.3	61,400	5.2	54,600	26.5	50,800	4.2	51,900	22.0	45,300	3.9
022	022	Single	8	800	17,800	16.2	22,100	5.7	20,400	26.5	18,100	4.8	18,700	19.1	14,000	3.8
030	030	Single	8	1000	23,400	15.9	30,600	5.7	26,900	25.6	24,900	4.8	24,600	18.9	19,800	3.9
036	036	Single	9	1200	29,100	17.4	35,600	5.8	33,200	27.4	29,600	4.9	30,600	20.4	23,100	4.0
042	042	Single	11	1300	36,000	16.7	43,100	5.5	41,300	25.6	36,000	4.8	37,800	19.5	27,400	3.9
048	048	Single	12	1500	39,300	15.3	50,000	5.3	46,900	25.5	41,900	4.7	42,500	18.7	33,400	4.0
060	060	Single	15	1800	53,500	14.9	64,500	4.8	61,700	23.6	54,500	4.3	56,300	17.7	44,000	3.7
070	066	Single	18	2000	57,100	13.8	74,700	4.6	66,400	21.7	62,100	4.1	60,500	16.2	50,700	3.6

Cooling capacities based upon 80.6°F DB, 66.2°F WB entering air temperature  
 Heating capacities based upon 68°F DB, 59°F WB entering air temperature  
 All ratings based upon operation at the lower voltage of dual voltage rated models.

11/21/2016

## Energy Star Compliance Table

Model	Tier 3	
	Ground Water	Ground Loop
026	Yes	Yes
038	Yes	Yes
049	Yes	Yes
064	Yes	Yes
072	Yes	Yes
022	Yes	Yes
030	Yes	Yes
036	Yes	Yes
042	Yes	Yes
048	Yes	Yes
060	Yes	Yes
070	Yes	Yes

### Energy Star Rating Criteria

In order for water-source heat pumps to be Energy Star rated they must meet or exceed the minimum efficiency requirements listed below.

#### Tier 3: 1/1/2012 - No Effective End Date Published

	EER	COP
Closed loop water-to-air	17.1	3.6
Open loop water-to-air	21.1	4.1
Closed loop water-to-water	16.1	3.1
Open loop water-to-water	20.1	3.5



**NOTE:** This product meets Energy Star requirements when purchased with a minimum 5 year warranty and appropriate coil components are used. Ask your contractor for details.

1/16/17

The manufacturer works continually to improve its products. As a result, the design and specifications of each product at the time of order may be changed without notice. Purchaser's approval of this data set signifies that the equipment is acceptable under the provisions of the job specification. Statements and other information contained herein are not express warranties and do not form the basis of any bargain between the parties, but are merely the manufacturer's opinion or commendation of its products. York and Affinity are registered trademarks of Johnson Controls, Inc., and are used with permission.

Contractor: \_\_\_\_\_ P.O.: \_\_\_\_\_

Engineer: \_\_\_\_\_

Project Name: \_\_\_\_\_ Unit Tag: \_\_\_\_\_

**Affinity Single & Dual Capacity  
Indoor Split Series  
2 - 6 Tons 60Hz**



**Dimensional Data**

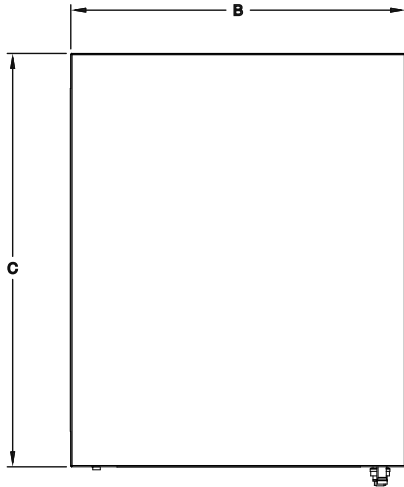

**TOP**

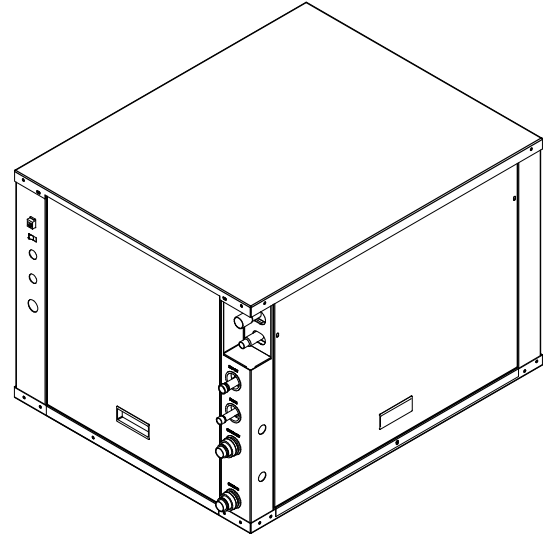

**FRONT**

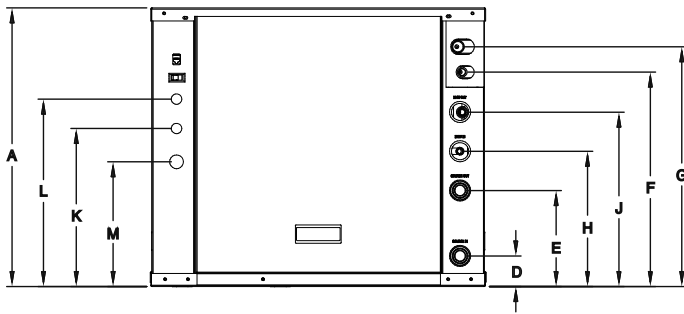

**SIDE**

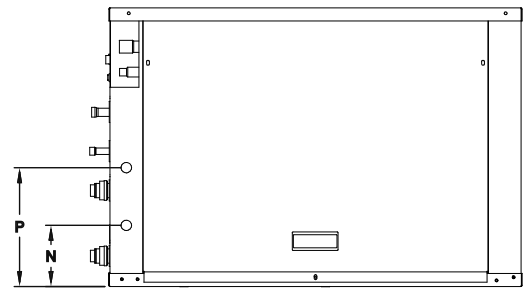

Model		Height	Width	Depth	Water In	Water Out	Service Valve		HWG In	HWG Out	Low Voltage	External Pump	Line Voltage	Knock Out	Knock Out
							Liquid	Gas							
		A	B	C	D	E	F	G	H	J	K	L	M	N	P
022-030	in.	19.3	22.5	26.5	1.93	6.93	15.2	16.8	9.4	11.9	12.1	14.3	9.5	4.6	8.2
	cm.	49.0	57.1	67.3	4.9	17.6	38.6	42.7	23.9	30.2	30.7	36.3	24.1	11.7	20.8
036-072	in.	21.25	25.62	31.6	2.3	7.21	16.4	18.3	10.3	13.3	12.1	14.3	9.5	4.7	9.1
	cm.	54.0	65.1	80.3	5.8	18.5	41.7	46.5	26.2	33.8	30.7	36.3	24.1	11.9	23.1

Dimensions are in inches.  
Decorative molding and water connections extend 1.2 in. [30.5 mm] beyond the front of the cabinet.

The manufacturer works continually to improve its products. As a result, the design and specifications of each product at the time of order may be changed without notice. Purchaser's approval of this data set signifies that the equipment is acceptable under the provisions of the job specification. Statements and other information contained herein are not express warranties and do not form the basis of any bargain between the parties, but are merely the manufacturer's opinion or commendation of its products. York and Affinity are registered trademarks of Johnson Controls, Inc., and are used with permission.

Contractor: \_\_\_\_\_ P.O.: \_\_\_\_\_

Engineer: \_\_\_\_\_

Project Name: \_\_\_\_\_ Unit Tag: \_\_\_\_\_

**Affinity Single & Dual Capacity  
Indoor Split Series  
2 - 6 Tons 60Hz**



## Physical Data

Model	022	030	036	042	048	060	070	026	038	049	064	72
Compressor (1 each)	Single Speed Scroll							Dual Capacity Scroll				
Factory Charge R410a, oz [kg]	56 [1.59]	56 [1.59]	56 [1.59]	74 [2.1]	90 [2.55]	92 [2.61]	108 [3.06]	52 [1.47]	56 [1.59]	90 [2.55]	92 [2.61]	104 [2.95]
Coax and Water Piping												
Water Connections Size - Swivel- in [mm]	1 [25.4]							1 [25.4]				
HWG Connection Size - Female Sweat (I.D.) - in [mm]	1/2 [12.7]							1/2 [12.7]				
Brass Service Valve - Liquid Line - in [mm]	3/8 [9.525]				1/2 [12.7]			3/8 [9.525]			1/2 [12.7]	
Brass Service Valve - Suction Line - in [mm]	5/8 [15.875]			3/4 [19.05]		7/8 [22.225]		5/8 [15.875]	3/4 [19.05]		7/8 [22.225]	
Coax and Piping Water Volume - gal [l]	0.7 [2.6]	1.0 [3.8]	1.3 [4.9]	1.3 [4.9]	1.6 [6.1]	1.6 [6.1]	2.3 [8.7]	0.7 [2.6]	1.3 [4.9]	1.6 [6.1]	1.6 [6.1]	2.3 [8.7]
Weight - Operating, lb [kg]	164 [74]	174 [79]	212 [96]	213 [97]	246 [112]	251 [114]	292 [132]	189 [86]	236 [107]	250 [113]	271 [123]	290 [132]
Weight - Packaged, lb [kg]	184 [83]	194 [88]	232 [105]	233 [106]	266 [121]	271 [123]	312 [142]	209 [95]	256 [116]	270 [122]	291 [132]	310 [141]

**NOTES:** All units have TXV expansion devices, and 1/2 in. [12.2 mm] and 3/4 in. [19.1 mm] electrical knockouts.  
Brass service valves are sweat type valves.

6/27/11

## Electrical Data

Model	Rated Voltage	Voltage Min/Max	Compressor				HWA Pump FLA	Ext Loop FLA	Total Unit FLA	Min Circ Amp	Max Fuse/HACR
			MCC	RLA	LRA	LRA*					
022	208-230/60/1	187/253	14.0	9.0	48.0	17.0	0.4	5.4	14.8	17.1	25
030	208-230/60/1	187/253	20.0	12.8	58.3	21.0	0.4	5.4	18.6	21.8	30
036	208-230/60/1	187/253	22.0	14.1	73.0	26.0	0.4	5.4	19.9	23.4	35
042	208-230/60/1	187/253	26.0	16.6	79.0	28.0	0.4	5.4	22.4	26.6	40
048	208-230/60/1	187/253	31.0	19.8	109.0	38.0	0.4	5.4	25.6	30.6	50
060	208-230/60/1	187/253	41.2	26.4	134.0	47.0	0.4	5.4	32.2	38.8	60
070	208-230/60/1	187/253	44.2	28.3	158.0	63.0	0.4	5.4	34.1	41.2	70
026	208-230/60/1	187/253	18.2	11.6	58.3	21.0	0.4	5.4	17.4	20.3	30
038	208-230/60/1	187/253	23.8	15.2	83.0	30.0	0.4	5.4	21.0	24.8	40
049	208-230/60/1	187/253	33.0	21.1	104.0	37.0	0.4	5.4	26.9	32.2	50
064	208-230/60/1	187/253	42.3	27.1	152.9	54.0	0.4	5.4	32.9	39.7	70
072	208-230/60/1	187/253	46.3	29.6	179.2	63.0	0.4	5.4	35.4	42.8	75

Rated voltage of 208-230/60/1  
HACR circuit breaker in USA only  
All fuses Class RK-5  
\* With optional IntelliStart

4/3/13

The manufacturer works continually to improve its products. As a result, the design and specifications of each product at the time of order may be changed without notice. Purchaser's approval of this data set signifies that the equipment is acceptable under the provisions of the job specification. Statements and other information contained herein are not express warranties and do not form the basis of any bargain between the parties, but are merely the manufacturer's opinion or commendation of its products. York and Affinity are registered trademarks of Johnson Controls, Inc., and are used with permission.

Contractor: \_\_\_\_\_ P.O.: \_\_\_\_\_

Engineer: \_\_\_\_\_

Project Name: \_\_\_\_\_ Unit Tag: \_\_\_\_\_



## Reference Calculations

Heating Calculations:	Cooling Calculations:
$LWT = EWT - \frac{HE}{gpm \times 500}$	$LWT = EWT + \frac{HR}{gpm \times 500}$
$LAT = EAT + \frac{HC}{cfm \times 1.08}$	$LAT(DB) = EAT(DB) - \frac{SC}{cfm \times 1.08}$
$TH = HC + HWC$	$LC = TC - SC$
	$S/T = \frac{SC}{TC}$

## Legend and Notes

### ABBREVIATIONS AND DEFINITIONS:

cfm = airflow, cubic feet/minute	HE = total heat of extraction, MBtu/h
EWT = entering water temperature, Fahrenheit	HWC = hot water generator capacity, MBtu/h
gpm = water flow in gallons/minute	EER = Energy Efficient Ratio
WPD = water pressure drop, PSI and feet of water	= Btu output/Watt input
EAT = entering air temperature, Fahrenheit (dry bulb/wet bulb)	COP = Coefficient of Performance
HC = air heating capacity, MBtu/h	= Btu output/Btu input
TC = total cooling capacity, MBtu/h	LWT = leaving water temperature, °F
SC = sensible cooling capacity, MBtu/h	LAT = leaving air temperature, °F
kW = total power unit input, kilowatts	TH = total heating capacity, MBtu/h
HR = total heat of rejection, MBtu/h	LC = latent cooling capacity, MBtu/h
	S/T = sensible to total cooling ratio

Hot water generator capacity based on 0.4 gpm flow per nominal unit ton at 90°F entering hot water temperature. Performance Data tables do not include water pumping watts and are based upon 15% (by volume) methanol antifreeze solution. Multiple Flow Rates (for EWT) are shown in the Performance Data tables. The lowest flow rate shown is used for geothermal open loop/well water systems with a minimum 50° F. The second flow rate shown is the minimum geothermal closed loop flow rate. The third flow rate shown is optimum for geothermal closed loop and the suggested flow rate for boiler tower applications. Interpolation between EWT, gpm and cfm data is permissible. Extrapolation for heating data down to 25°F is permissible. Catalog illustrations cover the general appearance of products at time of publication. We reserve the right to make changes in design and construction at any time without notice.

## Operating Limits

Operating Limits	Cooling		Heating	
	(°F)	(°C)	(°F)	(°C)
<b>Air Limits</b>				
Min. Ambient Air	45	7.2	45	7.2
Rated Ambient Air	80	26.7	70	21.1
Max. Ambient Air	100	37.8	85	29.4
Min. Entering Air	50	10.0	40	4.4
Rated Entering Air db/wb	80.6/66.2	27/19	68	20.0
Max. Entering Air db/wb	110/83	43/28.3	80	26.7
<b>Water Limits</b>				
Min. Entering Water	30	-1.1	20	-6.7
Normal Entering Water	50-110	10-43.3	30-70	-1.1
Max. Entering Water	120	48.9	90	32.2

**NOTE:** Minimum/maximum limits are only for start-up conditions, and are meant for bringing the space up to occupancy temperature. Units are not designed to operate at the minimum/maximum conditions on a regular basis. The operating limits are dependant upon three primary factors: 1) water temperature, 2) return air temperature, and 3) ambient temperature. When any of the factors are at the minimum or maximum levels, the other two factors must be at the normal level for proper and reliable unit operation.

The manufacturer works continually to improve its products. As a result, the design and specifications of each product at the time of order may be changed without notice. Purchaser's approval of this data set signifies that the equipment is acceptable under the provisions of the job specification. Statements and other information contained herein are not express warranties and do not form the basis of any bargain between the parties, but are merely the manufacturer's opinion or commendation of its products. York and Affinity are registered trademarks of Johnson Controls, Inc., and are used with permission.

Contractor: \_\_\_\_\_ P.O.: \_\_\_\_\_

Engineer: \_\_\_\_\_

Project Name: \_\_\_\_\_ Unit Tag: \_\_\_\_\_



## Pressure Drop

### Single Speed

Model	GPM	Pressure Drop (psi)				
		30°F	50°F	70°F	90°F	110°F
<b>022</b>	3	1.0	0.1	0.9	0.8	0.8
	4.5	2.1	1.9	1.8	1.6	1.5
	6	3.2	2.9	2.7	2.4	2.3
	8	5.1	4.6	3.9	3.7	3.5
<b>030</b>	4	1.6	1.5	1.4	1.3	1.2
	6	3.2	3.0	2.8	2.6	2.4
	8	4.7	4.4	4.1	3.8	3.5
	10	7.0	6.5	5.6	5.5	5.1
<b>036</b>	5	1.6	1.5	1.4	1.3	1.2
	7	2.8	2.7	2.5	2.3	2.2
	9	4.2	3.9	3.7	3.4	3.2
	12	6.7	6.4	6.2	5.6	5.4
<b>042</b>	5	1.5	1.4	1.3	1.2	1.1
	8	3.5	3.3	3.1	2.9	2.7
	11	5.6	5.2	4.9	4.6	4.2
	14	8.1	7.9	7.6	7.3	7.0
<b>048</b>	6	1.3	1.2	1.1	1.0	1.0
	9	2.7	2.6	2.4	2.2	2.1
	12	4.1	3.9	3.6	3.4	3.1
	16	6.9	6.7	6.4	6.2	5.9
<b>060</b>	9	2.1	2.0	1.9	1.8	1.6
	12	3.9	3.6	3.4	3.2	2.9
	15	5.7	5.3	5.0	4.6	4.3
	20	9.5	8.9	8.3	7.8	7.2
<b>070</b>	12	3.3	3.1	2.9	2.7	2.5
	15	5.0	4.7	4.4	4.1	3.8
	18	6.7	6.3	5.9	5.5	5.1
	24	9.7	9.5	9.2	8.4	7.9

1/4/16

### Dual Capacity

Model	GPM	Pressure Drop (psi)				
		30°F	50°F	70°F	90°F	110°F
<b>026 full load</b>	4	1.4	1.3	1.2	1.1	1.0
	6	3.3	3.1	2.9	2.7	2.5
	8	5.1	4.8	4.5	4.2	3.9
	10	7.2	6.9	6.6	6.3	6.0
<b>026 part load</b>	3	1.0	0.9	0.9	0.8	0.7
	5	2.5	2.3	2.2	2.0	1.9
	7	3.9	3.6	3.4	3.2	2.9
	9	6.2	5.9	5.7	5.5	5.2
<b>038 full load</b>	5	1.2	1.2	1.1	1.0	1.0
	7	2.5	2.3	2.2	2.0	1.9
	9	3.6	3.4	3.2	3.0	2.8
	11	5.2	5.0	4.8	4.6	4.4
<b>038 part load</b>	4	0.9	0.9	0.8	0.8	0.7
	6	2.0	1.9	1.8	1.7	1.6
	8	2.9	2.8	2.7	2.5	2.3
	10	4.1	4.0	3.8	3.6	3.4
<b>049 full load</b>	6	1.3	1.2	1.1	1.1	1.0
	9	2.7	2.6	2.4	2.2	2.1
	12	4.2	3.9	3.7	3.3	3.2
	15	6.0	5.7	5.5	5.2	5.0
<b>049 part load</b>	5	0.9	0.8	0.8	0.7	0.7
	8	2.2	2.0	1.9	1.7	1.6
	11	3.5	3.3	3.1	2.8	2.7
	14	5.1	4.9	4.7	4.4	4.2
<b>064 full load</b>	8	1.8	1.7	1.6	1.5	1.4
	12	4.1	3.8	3.6	3.4	3.1
	16	6.5	6.1	5.7	5.3	4.9
	20	9.7	9.2	8.6	8.2	7.6
<b>064 part load</b>	6	1.1	1.0	0.9	0.9	0.8
	10	3.3	3.1	2.9	2.7	2.5
	14	5.6	5.3	4.9	4.6	4.3
	18	8.4	8.1	7.7	7.4	7.1
<b>072 full load</b>	12	3.3	3.1	2.9	2.7	2.5
	15	5.0	4.7	4.4	4.1	3.8
	18	6.8	6.4	6.0	5.5	5.1
	21	8.4	8.0	7.6	7.1	6.8
<b>072 part load</b>	10	2.4	2.3	2.1	2.0	1.8
	13	4.0	3.7	3.5	3.3	3.0
	16	5.6	5.2	4.9	4.6	4.2
	19	7.1	6.8	6.5	6.2	5.9

1/4/17

The manufacturer works continually to improve its products. As a result, the design and specifications of each product at the time of order may be changed without notice. Purchaser's approval of this data set signifies that the equipment is acceptable under the provisions of the job specification. Statements and other information contained herein are not express warranties and do not form the basis of any bargain between the parties, but are merely the manufacturer's opinion or commendation of its products. York and Affinity are registered trademarks of Johnson Controls, Inc., and are used with permission.

Contractor: \_\_\_\_\_ P.O.: \_\_\_\_\_

Engineer: \_\_\_\_\_

Project Name: \_\_\_\_\_ Unit Tag: \_\_\_\_\_



## Model 022 - Performance Data

### 022 - Single Speed

EWT °F	Flow gpm	WPD		HEATING - EAT 70°F							COOLING - EAT 80/67 °F							
		PSI	FT	Airflow cfm	HC Mbtu/h	Power kW	HE Mbtu/h	LAT °F	COP	HWC Mbtu/h	Airflow cfm	TC Mbtu/h	SC Mbtu/h	S/T Ratio	Power kW	HR Mbtu/h	EER	HWC Mbtu/h
20	3.0	1.0	2.4	Operation not recommended							Operation not recommended							
	4.5	2.1	4.9	Operation not recommended							Operation not recommended							
	6.0	3.2	7.3	600	11.7	1.17	7.7	88.0	2.92	1.6								
700				11.9	1.18	7.9	85.7	2.96	1.5									
30	3.0	1.0	2.3	Operation not recommended							Operation not recommended							
	4.5	2.0	4.7	600	13.4	1.15	9.5	90.7	3.43	1.7	600	19.2	11.5	0.60	0.67	21.5	28.8	-
				700	14.0	1.18	10.0	88.5	3.48	1.6	700	19.5	12.6	0.64	0.70	21.9	27.8	-
				600	14.6	1.20	10.5	92.5	3.57	1.8	600	19.3	11.5	0.60	0.65	21.8	29.8	-
	6.0	3.1	7.1	700	14.9	1.21	10.8	89.7	3.61	1.6	700	19.8	12.6	0.64	0.68	22.1	29.1	-
40				3.0	1.0	2.2	Operation not recommended							Operation not recommended				
	4.5	2.0	4.6	600	15.9	1.18	11.8	94.5	3.93	1.9	600	20.3	13.3	0.65	0.74	22.9	27.5	-
				700	16.4	1.21	12.3	91.7	3.99	1.8	700	20.7	14.5	0.70	0.78	23.4	26.7	-
				600	16.7	1.21	12.6	95.8	4.04	2.0	600	20.5	13.3	0.65	0.72	22.9	28.6	-
	6.0	3.0	6.9	700	17.3	1.24	13.1	92.9	4.11	1.8	700	21.0	14.5	0.69	0.75	23.5	27.9	-
50				3.0	0.9	2.1	600	17.7	1.22	13.5	97.2	4.26	2.1	600	21.0	14.4	0.69	0.83
	4.5	1.9	4.4	700	18.2	1.23	14.0	94.1	4.33	2.0	700	21.5	15.9	0.74	0.85	24.4	25.4	1.2
				600	18.3	1.22	14.1	98.2	4.40	2.2	600	21.2	14.4	0.68	0.81	23.9	26.1	1.0
				700	18.8	1.23	14.6	94.9	4.48	2.0	700	21.7	16.0	0.74	0.83	24.6	26.3	1.1
	6.0	2.9	6.7	600	19.1	1.25	14.9	99.5	4.50	2.2	600	21.5	14.8	0.69	0.80	24.2	26.7	1.0
700				19.7	1.26	15.4	96.1	4.58	2.1	700	22.1	16.4	0.74	0.82	24.9	27.0	1.1	
60	3.0	0.9	2.1	600	20.1	1.26	15.8	101.1	4.69	2.4	600	20.4	14.1	0.69	0.93	23.6	21.8	1.3
				700	20.6	1.27	16.3	97.3	4.77	2.2	700	21.0	15.6	0.74	0.95	24.2	22.0	1.4
	4.5	1.9	4.3	600	20.9	1.26	16.7	102.3	4.89	2.4	600	20.6	14.2	0.69	0.91	23.7	22.6	1.2
				700	21.4	1.26	17.1	98.3	4.97	2.3	700	21.2	15.7	0.74	0.93	24.3	22.8	1.3
				600	21.7	1.28	17.3	103.4	4.95	2.5	600	20.9	14.5	0.70	0.90	24.0	23.2	1.1
6.0	2.8	6.5	700	22.2	1.29	17.7	99.3	5.03	2.3	700	21.5	16.1	0.75	0.92	24.6	23.4	1.3	
			70	3.0	0.9	2.0	600	22.6	1.30	18.1	104.8	5.09	2.7	600	19.8	13.8	0.70	1.04
700	31.2	1.83					25.0	111.3	5.00	2.5	700	20.4	15.3	0.75	1.06	24.0	19.3	1.7
4.5	1.8	4.2		600	23.6	1.29	19.2	106.4	5.34	2.7	600	20.0	13.9	0.70	1.01	23.5	19.8	1.5
				700	24.0	1.29	19.6	101.8	5.44	2.5	700	20.6	15.4	0.75	1.03	24.1	20.0	1.7
				600	22.9	1.30	19.5	105.3	5.16	2.8	600	20.3	14.3	0.70	1.00	23.7	20.3	1.4
6.0	2.7	6.3	700	24.6	1.32	20.1	102.5	5.46	2.6	700	20.9	15.8	0.76	1.02	24.4	20.5	1.6	
			80	3.0	0.8	1.9	600	24.8	1.34	20.2	108.3	5.42	3.0	600	18.6	13.6	0.73	1.17
700	25.2	1.34					20.6	103.3	5.52	2.8	700	19.2	15.0	0.78	1.19	23.2	16.1	2.2
4.5	1.7	4.0		600	26.0	1.33	21.5	110.1	5.71	3.1	600	18.8	13.7	0.73	1.14	22.7	16.5	1.9
				700	26.3	1.32	21.8	104.8	5.82	2.8	700	19.3	15.1	0.78	1.16	23.3	16.7	2.1
				600	26.4	1.36	21.7	110.7	5.68	3.2	600	19.1	14.0	0.73	1.13	23.0	16.9	1.8
6.0	2.6	6.0	700	26.7	1.35	22.0	105.3	5.79	2.9	700	19.7	15.5	0.79	1.15	23.6	17.1	2.0	
			90	3.0	0.8	1.9	600	27.1	1.39	22.3	111.7	5.72	3.3	600	17.5	13.3	0.76	1.30
700	27.3	1.37					22.6	106.1	5.83	3.1	700	17.9	14.7	0.82	1.33	22.5	13.5	2.7
4.5	1.7	3.9		600	28.4	1.37	23.8	113.9	6.06	3.4	600	17.6	13.4	0.76	1.27	22.1	13.9	2.4
				700	28.6	1.36	24.0	107.9	6.19	3.2	700	18.1	14.8	0.82	1.29	22.5	14.0	2.6
				600	28.6	1.40	23.8	114.1	5.97	3.5	600	18.1	14.0	0.77	1.26	22.4	14.4	2.2
6.0	2.5	5.8	700	28.7	1.38	24.0	108.0	6.10	3.3	700	18.4	15.2	0.83	1.28	22.8	14.4	2.4	
			100	3.0	0.8	1.8	Operation not recommended							Operation not recommended				
4.5	1.6	3.7		600	16.2	1.30	0.80	1.45	21.1	11.2	2.9							
				700	16.6	1.43	0.86	1.47	21.7	11.3	3.2							
				600	16.4	1.33	0.81	1.43	21.3	11.5	2.7							
6.0	2.4	5.6		700	16.9	1.47	0.87	1.46	21.9	11.6	3.0							
			110	3.0	0.8	1.7	Operation not recommended							Operation not recommended				
4.5	1.6	3.6		600	14.7	1.25	0.85	1.62	20.4	9.1	3.6							
				700	15.2	1.38	0.91	1.65	20.8	9.2	3.9							
				600	15.0	1.28	0.86	1.61	20.5	9.3	3.3							
6.0	2.3	5.4		700	15.4	1.42	0.92	1.64	21.0	9.4	3.7							
			120	3.0	0.7	1.7	Operation not recommended							Operation not recommended				
4.5	1.5	3.5		600	13.9	1.27	0.92	1.86	20.2	7.4	4.3							
				700	14.1	1.38	0.98	1.91	20.7	7.4	4.7							
				600	14.0	1.27	0.91	1.80	20.2	7.8	4.0							
6.0	2.2	5.2		700	14.3	1.38	0.97	1.86	20.6	7.7	4.4							

3/7/17

Multiple Flow Rates (for EWT) are shown in the table above. The lowest flow rate shown is used for geothermal open loop/well water systems with a minimum 50° F. The second flow rate shown is the minimum geothermal closed loop flow rate. The third flow rate shown is optimum for geothermal closed loop and the suggested flow rate for boiler tower applications.

The manufacturer works continually to improve its products. As a result, the design and specifications of each product at the time of order may be changed without notice. Purchaser's approval of this data set signifies that the equipment is acceptable under the provisions of the job specification. Statements and other information contained herein are not express warranties and do not form the basis of any bargain between the parties, but are merely the manufacturer's opinion or commendation of its products. York and Affinity are registered trademarks of Johnson Controls, Inc., and are used with permission.



Contractor: \_\_\_\_\_ P.O.: \_\_\_\_\_

Engineer: \_\_\_\_\_

Project Name: \_\_\_\_\_ Unit Tag: \_\_\_\_\_

**Affinity Single & Dual Capacity  
Indoor Split Series  
2 - 6 Tons 60Hz**



# Model 030 - Performance Data

## 030 - Single Speed

EWT °F	Flow gpm	WPD		HEATING - EAT 70°F							COOLING - EAT 80/67 °F							
		PSI	FT	Airflow cfm	HC Mbtu/h	Power kW	HE Mbtu/h	LAT °F	COP	HWC Mbtu/h	Airflow cfm	TC Mbtu/h	SC Mbtu/h	S/T Ratio	Power kW	HR Mbtu/h	EER	HWC Mbtu/h
20	4.0	1.6	3.8	Operation not recommended							Operation not recommended							
	6.0	3.3	7.6	Operation not recommended							Operation not recommended							
	8.0	4.8	11.1	700	16.6	1.58	11.2	92.0	3.08	2.2	Operation not recommended							
				900	17.1	1.59	11.7	87.6	3.15	2.0	Operation not recommended							
30	4.0	1.6	3.7	Operation not recommended							Operation not recommended							
	6.0	3.2	7.4	700	18.7	1.60	13.2	94.7	3.43	2.4	700	21.5	12.9	0.60	0.92	24.6	23.3	-
				900	19.4	1.64	13.9	90.0	3.48	2.2	900	21.8	14.1	0.65	0.97	25.1	22.4	-
	8.0	4.7	10.8	700	20.1	1.67	14.4	96.6	3.53	2.4	700	21.6	12.9	0.60	0.90	24.8	24.1	-
900				20.7	1.68	15.0	91.3	3.61	2.2	900	22.1	14.1	0.64	0.94	25.3	23.5	-	
40	4.0	1.5	3.6	Operation not recommended							Operation not recommended							
	6.0	3.1	7.1	700	21.8	1.65	16.2	98.9	3.87	2.6	700	23.9	15.4	0.65	1.02	27.4	23.6	-
				900	22.6	1.68	16.8	93.2	3.93	2.4	900	24.4	16.9	0.69	1.06	28.0	22.9	-
	8.0	4.5	10.4	700	23.0	1.69	17.2	100.4	3.98	2.7	700	24.1	15.4	0.64	0.98	27.5	24.5	-
900				23.8	1.73	17.9	94.5	4.04	2.5	900	24.7	16.9	0.68	1.03	28.2	23.9	-	
50	4.0	1.5	3.5	700	24.1	1.71	18.3	101.9	4.14	2.8	700	25.8	17.2	0.67	1.14	29.7	22.7	1.4
				900	24.9	1.73	19.0	95.6	4.21	2.6	900	26.5	19.0	0.72	1.16	30.5	22.9	1.5
	6.0	3.0	6.9	700	25.0	1.71	19.1	103.0	4.28	2.9	700	26.0	17.3	0.66	1.11	29.8	23.5	1.3
				900	25.7	1.73	19.8	96.5	4.35	2.7	900	26.8	19.1	0.71	1.13	30.6	23.7	1.4
8.0	4.4	10.1	700	26.1	1.75	20.2	104.6	4.38	3.0	700	26.5	17.7	0.67	1.10	30.2	24.1	1.2	
			900	26.9	1.77	20.9	97.7	4.45	2.8	900	27.2	19.6	0.72	1.12	31.0	24.3	1.4	
60	4.0	1.4	3.3	700	27.3	1.77	21.3	106.2	4.52	3.2	700	25.9	17.8	0.69	1.26	30.2	20.6	1.7
				900	28.0	1.79	21.9	98.8	4.60	3.0	900	26.6	19.7	0.74	1.28	31.0	20.7	1.8
	6.0	2.9	6.7	700	28.4	1.77	22.4	107.6	4.71	3.3	700	26.1	17.9	0.69	1.23	30.3	21.3	1.6
				900	29.1	1.78	23.0	100.0	4.79	3.0	900	26.9	19.8	0.74	1.25	31.1	21.5	1.7
8.0	4.2	9.8	700	29.4	1.81	23.3	108.9	4.76	3.4	700	26.6	18.4	0.69	1.22	30.7	21.8	1.5	
			900	30.1	1.82	23.9	101.0	4.85	3.1	900	27.3	20.4	0.75	1.24	31.5	22.0	1.6	
70	4.0	1.4	3.2	700	30.6	1.84	24.3	110.4	4.87	3.6	700	26.0	18.5	0.71	1.38	30.7	18.8	2.1
				900	31.2	1.83	25.0	102.1	5.00	3.3	900	26.7	20.5	0.77	1.41	31.5	19.0	2.2
	6.0	2.8	6.5	700	31.9	1.83	25.6	112.2	5.10	3.7	700	26.2	18.6	0.71	1.35	30.8	19.5	2.0
				900	32.5	1.83	26.2	103.4	5.20	3.4	900	27.0	20.6	0.76	1.37	31.6	19.6	2.1
8.0	4.1	9.5	700	32.7	1.87	26.3	113.3	5.12	3.8	700	26.7	19.1	0.72	1.33	31.2	20.0	1.8	
			900	33.3	1.87	26.9	104.3	5.22	3.5	900	27.4	21.1	0.77	1.36	32.0	20.1	2.0	
80	4.0	1.4	3.1	700	33.7	1.92	27.2	114.6	5.15	4.0	700	24.1	18.0	0.75	1.54	29.4	15.6	2.6
				900	34.2	1.91	27.7	105.2	5.25	3.7	900	24.8	19.9	0.80	1.57	30.1	15.7	2.8
	6.0	2.7	6.3	700	35.3	1.91	28.8	116.7	5.43	4.1	700	24.3	18.1	0.74	1.50	29.4	16.2	2.5
				900	35.7	1.89	29.3	106.8	5.53	3.8	900	25.0	20.0	0.80	1.53	30.2	16.3	2.7
8.0	4.0	9.2	700	35.8	1.95	29.2	117.4	5.39	4.3	700	24.7	18.5	0.75	1.49	29.8	16.6	2.3	
			900	36.2	1.93	29.6	107.2	5.50	3.9	900	25.4	20.5	0.81	1.52	30.6	16.7	2.5	
90	4.0	1.3	3.0	700	36.9	2.00	30.0	118.7	5.40	4.5	700	22.2	17.4	0.79	1.71	28.0	13.0	3.3
				900	37.2	1.98	30.4	108.2	5.51	4.2	900	22.8	19.3	0.85	1.74	28.8	13.1	3.5
	6.0	2.6	6.0	700	38.8	1.98	31.8	121.3	5.73	4.6	700	22.4	17.5	0.78	1.66	28.1	13.5	3.1
				900	39.0	1.95	32.0	110.1	5.85	4.3	900	23.0	19.4	0.84	1.69	28.8	13.6	3.3
8.0	3.8	8.8	700	38.9	2.02	32.0	121.5	5.64	4.8	700	23.3	17.5	0.75	1.65	28.3	14.1	2.8	
			900	39.1	1.99	32.3	110.2	5.76	4.4	900	23.4	19.9	0.85	1.68	29.1	13.9	3.2	
100	4.0	1.3	2.9	Operation not recommended							Operation not recommended							
	6.0	2.5	5.8	700	21.1	17.0	0.80	1.87	27.5	11.3	3.8	Operation not recommended						
				900	21.7	18.8	0.87	1.91	28.2	11.4	4.1	Operation not recommended						
	8.0	3.7	8.5	700	21.5	17.4	0.81	1.85	27.8	11.6	3.5	Operation not recommended						
900				22.1	19.3	0.87	1.89	28.5	11.7	3.9	Operation not recommended							
110	4.0	1.2	2.8	Operation not recommended							Operation not recommended							
	6.0	2.4	5.6	700	19.8	16.4	0.83	2.08	27.2	9.5	4.6	Operation not recommended						
				900	20.4	18.1	0.89	2.12	27.6	9.6	5.0	Operation not recommended						
	8.0	3.5	8.2	700	20.1	16.8	0.83	2.06	27.4	9.8	4.3	Operation not recommended						
900				20.7	18.6	0.90	2.10	27.9	9.9	4.7	Operation not recommended							
120	4.0	1.2	2.7	Operation not recommended							Operation not recommended							
	6.0	2.3	5.4	700	18.9	16.6	0.88	2.35	27.0	8.0	5.5	Operation not recommended						
				900	19.3	18.0	0.93	2.42	27.5	8.0	6.0	Operation not recommended						
	8.0	3.4	7.9	700	19.1	16.6	0.87	2.28	26.9	8.4	5.1	Operation not recommended						
900				19.5	18.0	0.92	2.35	27.5	8.3	5.7	Operation not recommended							

Multiple Flow Rates (for EWT) are shown in the table above. The lowest flow rate shown is used for geothermal open loop/well water systems with a minimum 50° F. The second flow rate shown is the minimum geothermal closed loop flow rate. The third flow rate shown is optimum for geothermal closed loop and the suggested flow rate for boiler tower applications. 3/7/17

The manufacturer works continually to improve its products. As a result, the design and specifications of each product at the time of order may be changed without notice. Purchaser's approval of this data set signifies that the equipment is acceptable under the provisions of the job specification. Statements and other information contained herein are not express warranties and do not form the basis of any bargain between the parties, but are merely the manufacturer's opinion or commendation of its products. York and Affinity are registered trademarks of Johnson Controls, Inc., and are used with permission.

Contractor: \_\_\_\_\_ P.O.: \_\_\_\_\_

Engineer: \_\_\_\_\_

Project Name: \_\_\_\_\_ Unit Tag: \_\_\_\_\_

**Affinity Single & Dual Capacity  
Indoor Split Series  
2 - 6 Tons 60Hz**



# Model 036 - Performance Data

## 036 - Single Speed

EWT °F	Flow gpm	WPD		HEATING - EAT 70°F							COOLING - EAT 80/67 °F							
		PSI	FT	Airflow cfm	HC Mbtu/h	Power kW	HE Mbtu/h	LAT °F	COP	HWC Mbtu/h	Airflow cfm	TC Mbtu/h	SC Mbtu/h	S/T Ratio	Power kW	HR Mbtu/h	EER	HWC Mbtu/h
20	5.0	1.6	3.8	Operation not recommended							Operation not recommended							
	7.0	2.9	6.8	Operation not recommended							Operation not recommended							
	9.0	4.3	9.9	1000	20.1	1.84	13.8	88.6	3.20	2.7	Operation not recommended							
				1200	20.6	1.88	14.2	85.9	3.21	2.4	Operation not recommended							
30	5.0	1.6	3.7	Operation not recommended							Operation not recommended							
	7.0	2.8	6.6	1000	22.4	1.86	16.0	90.7	3.52	2.9	1000	27.7	16.2	0.59	1.09	31.4	25.4	-
				1200	23.3	1.91	16.8	88.0	3.57	2.6	1200	28.1	17.7	0.63	1.15	32.0	24.5	-
	9.0	4.2	9.6	1000	24.2	1.92	17.6	92.4	3.69	3.0	1000	27.8	16.2	0.58	1.06	31.6	26.3	-
1200				24.8	1.96	18.1	89.1	3.71	2.7	1200	28.5	17.7	0.62	1.11	32.3	25.7	-	
40	5.0	1.5	3.6	Operation not recommended							Operation not recommended							
	7.0	2.8	6.4	1000	26.3	1.93	19.7	94.4	4.00	3.2	1000	30.6	19.1	0.62	1.20	34.7	25.4	-
				1200	27.2	1.97	20.5	91.0	4.06	3.0	1200	31.1	20.8	0.67	1.26	35.4	24.7	-
	9.0	4.0	9.3	1000	27.7	1.98	21.0	95.7	4.11	3.3	1000	30.8	19.1	0.62	1.17	34.8	26.4	-
1200				28.7	2.02	21.8	92.1	4.17	3.0	1200	31.5	20.8	0.66	1.22	35.7	25.8	-	
50	5.0	1.5	3.5	1000	29.2	2.00	22.4	97.0	4.29	3.5	1000	32.7	20.9	0.64	1.35	37.3	24.2	1.7
				1200	30.1	2.03	23.2	93.2	4.36	3.2	1200	33.6	23.2	0.69	1.38	38.3	24.4	1.8
	7.0	2.7	6.2	1000	30.2	2.00	23.4	98.0	4.43	3.6	1000	33.0	21.1	0.64	1.32	37.5	25.1	1.6
				1200	31.2	2.02	24.3	94.0	4.51	3.3	1200	33.9	23.3	0.69	1.34	38.5	25.3	1.7
9.0	3.9	9.1	1000	31.7	2.05	24.7	99.3	4.54	3.7	1000	33.6	21.6	0.64	1.30	38.0	25.7	1.4	
			1200	32.6	2.07	25.5	95.2	4.62	3.4	1200	34.5	23.9	0.69	1.33	39.0	25.9	1.6	
60	5.0	1.4	3.3	1000	32.9	2.06	25.9	100.5	4.68	3.9	1000	32.5	22.2	0.68	1.51	37.7	21.5	2.0
				1200	33.7	2.08	26.6	96.0	4.76	3.6	1200	33.4	24.5	0.73	1.54	38.7	21.7	2.1
	7.0	2.6	6.0	1000	34.2	2.06	27.2	101.7	4.87	4.0	1000	32.8	22.3	0.68	1.47	37.9	22.3	1.9
				1200	35.0	2.07	27.9	97.0	4.96	3.7	1200	33.7	24.7	0.73	1.50	38.9	22.4	2.0
9.0	3.8	8.8	1000	35.4	2.10	28.2	102.8	4.93	4.2	1000	33.4	22.9	0.68	1.46	38.4	22.8	1.7	
			1200	36.2	2.12	29.0	97.9	5.02	3.8	1200	34.3	25.3	0.74	1.49	39.4	23.0	1.9	
70	5.0	1.4	3.2	1000	36.5	2.13	29.3	103.8	5.03	4.4	1000	32.3	23.4	0.72	1.68	38.1	19.3	2.5
				1200	37.5	2.13	30.2	98.9	5.16	4.1	1200	33.2	25.9	0.78	1.71	39.1	19.5	2.6
	7.0	2.5	5.8	1000	38.1	2.12	30.9	105.3	5.28	4.5	1000	32.6	23.5	0.72	1.63	38.2	20.0	2.3
				1200	38.8	2.12	31.6	100.0	5.38	4.2	1200	33.5	26.0	0.78	1.66	39.2	20.2	2.5
9.0	3.7	8.5	1000	39.1	2.16	31.7	106.2	5.30	4.7	1000	33.2	24.1	0.73	1.62	38.7	20.5	2.2	
			1200	39.8	2.16	32.4	100.7	5.40	4.3	1200	34.1	26.7	0.78	1.65	39.7	20.7	2.4	
80	5.0	1.4	3.1	1000	39.9	2.19	32.4	106.9	5.33	4.9	1000	30.5	22.9	0.75	1.86	36.8	16.4	3.1
				1200	40.4	2.18	33.0	101.2	5.43	4.6	1200	31.3	25.4	0.81	1.90	37.8	16.5	3.3
	7.0	2.4	5.6	1000	41.8	2.18	34.4	108.7	5.62	5.1	1000	30.7	23.1	0.75	1.81	36.9	17.0	2.9
				1200	42.3	2.16	34.9	102.7	5.73	4.7	1200	31.6	25.5	0.81	1.85	37.9	17.1	3.1
9.0	3.5	8.2	1000	42.4	2.22	34.8	109.3	5.59	5.2	1000	31.2	23.7	0.76	1.80	37.4	17.4	2.7	
			1200	42.9	2.21	35.3	103.1	5.70	4.8	1200	32.1	26.2	0.82	1.83	38.3	17.5	3.0	
90	5.0	1.3	3.0	1000	43.3	2.26	35.5	110.1	5.61	5.5	1000	28.6	22.5	0.79	2.04	35.5	14.0	3.9
				1200	43.6	2.23	36.0	103.7	5.72	5.1	1200	29.3	24.9	0.85	2.08	36.4	14.1	4.1
	7.0	2.3	5.4	1000	45.5	2.24	37.8	112.1	5.95	5.7	1000	28.8	22.6	0.79	1.99	35.6	14.5	3.6
				1200	45.8	2.21	38.2	105.3	6.07	5.3	1200	29.6	25.1	0.85	2.03	36.5	14.6	3.9
9.0	3.4	7.9	1000	45.7	2.29	37.9	112.3	5.86	5.9	1000	29.5	23.3	0.79	1.93	36.1	15.3	3.4	
			1200	45.9	2.25	38.2	105.4	5.98	5.4	1200	30.1	25.7	0.85	2.01	37.0	15.0	3.7	
100	5.0	1.3	2.9	Operation not recommended							Operation not recommended							
	7.0	2.2	5.2	1000	27.2	2.18	0.80	2.22	34.7	12.3	4.5	Operation not recommended						
				1200	27.9	2.42	0.87	2.26	35.7	12.4	4.8	Operation not recommended						
	9.0	3.3	7.6	1000	27.6	2.24	0.81	2.20	35.1	12.6	4.1	Operation not recommended						
1200				28.4	2.48	0.87	2.24	36.0	12.7	4.6	Operation not recommended							
110	5.0	1.2	2.8	Operation not recommended							Operation not recommended							
	7.0	2.2	5.0	1000	25.6	2.11	0.82	2.44	33.9	10.5	5.4	Operation not recommended						
				1200	26.3	2.33	0.89	2.49	34.8	10.5	5.9	Operation not recommended						
	9.0	3.2	7.3	1000	26.0	2.16	0.83	2.42	34.2	10.7	5.0	Operation not recommended						
1200				26.7	2.39	0.90	2.47	35.1	10.8	5.6	Operation not recommended							
120	5.0	1.2	2.7	Operation not recommended							Operation not recommended							
	7.0	2.1	4.8	1000	24.2	2.1	0.09	2.76	33.6	8.8	6.5	Operation not recommended						
				1200	24.6	2.3	0.09	2.83	34.3	8.7	7.1	Operation not recommended						
	9.0	3.0	7.0	1000	24.4	2.1	0.09	2.67	33.5	9.1	6.1	Operation not recommended						
1200				24.9	2.3	0.09	2.75	34.3	9.1	6.7	Operation not recommended							

3/7/17

Multiple Flow Rates (for EWT) are shown in the table above. The lowest flow rate shown is used for geothermal open loop/well water systems with a minimum 50° F. The second flow rate shown is the minimum geothermal closed loop flow rate. The third flow rate shown is optimum for geothermal closed loop and the suggested flow rate for boiler tower applications.

The manufacturer works continually to improve its products. As a result, the design and specifications of each product at the time of order may be changed without notice. Purchaser's approval of this data set signifies that the equipment is acceptable under the provisions of the job specification. Statements and other information contained herein are not express warranties and do not form the basis of any bargain between the parties, but are merely the manufacturer's opinion or commendation of its products. York and Affinity are registered trademarks of Johnson Controls, Inc., and are used with permission.

Contractor: \_\_\_\_\_ P.O.: \_\_\_\_\_

Engineer: \_\_\_\_\_

Project Name: \_\_\_\_\_ Unit Tag: \_\_\_\_\_



# Model 042 - Performance Data

## 042 - Single Speed

EWT °F	Flow gpm	WPD		HEATING - EAT 70°F							COOLING - EAT 80/67 °F							
		PSI	FT	Airflow cfm	HC Mbtu/h	Power kW	HE Mbtu/h	LAT °F	COP	HWC Mbtu/h	Airflow cfm	TC Mbtu/h	SC Mbtu/h	S/T Ratio	Power kW	HR Mbtu/h	EER	HWC Mbtu/h
20	5.0	1.5	3.5	Operation not recommended							Operation not recommended							
	8.0	3.6	8.4	Operation not recommended							Operation not recommended							
	11.0	5.7	13.2	1100	25.2	2.45	16.9	91.2	3.02	4.1	Operation not recommended							
				1400	25.9	2.48	17.4	87.1	3.06	3.7	Operation not recommended							
30	5.0	1.5	3.4	Operation not recommended							Operation not recommended							
	8.0	3.5	8.1	1100	27.3	2.40	19.1	93.0	3.33	4.3	1100	34.1	22.6	0.66	1.60	39.6	21.3	-
				1400	28.5	2.47	20.0	88.8	3.38	3.9	1400	34.6	24.7	0.71	1.69	40.4	20.5	-
				1100	29.5	2.50	21.0	94.8	3.46	4.4	1100	34.3	22.6	0.66	1.55	39.8	22.1	-
				1400	30.3	2.53	21.7	90.0	3.51	4.0	1400	35.1	24.7	0.70	1.63	40.7	21.5	-
40	5.0	1.4	3.3	Operation not recommended							Operation not recommended							
	8.0	3.4	7.9	1100	31.7	2.46	23.3	96.7	3.78	4.7	1100	38.5	25.7	0.67	1.73	44.4	22.2	-
				1400	32.8	2.51	24.3	91.7	3.83	4.3	1400	39.2	28.1	0.72	1.82	45.4	21.6	-
				1100	33.5	2.52	24.8	98.2	3.89	4.9	1100	38.8	25.7	0.66	1.68	44.5	23.0	-
				1400	34.6	2.57	25.8	92.9	3.95	4.4	1400	39.7	28.1	0.71	1.76	45.7	22.5	-
50	5.0	1.4	3.2	1100	34.9	2.52	26.3	99.3	4.06	5.1	1100	41.9	27.5	0.66	1.92	48.5	21.8	2.5
				1400	36.0	2.55	27.2	93.8	4.13	4.7	1400	43.1	30.4	0.71	1.96	49.8	22.0	2.6
	8.0	3.3	7.7	1100	36.1	2.52	27.5	100.4	4.20	5.3	1100	42.3	27.7	0.65	1.87	48.7	22.6	2.3
				1400	37.2	2.55	28.5	94.6	4.27	4.8	1400	43.5	30.6	0.70	1.91	50.0	22.8	2.5
				1100	37.8	2.58	29.0	101.8	4.29	5.4	1100	43.0	28.4	0.66	1.85	49.3	23.2	2.1
			1400	38.9	2.61	30.0	95.7	4.37	5.0	1400	44.2	31.4	0.71	1.89	50.6	23.4	2.4	
60	5.0	1.3	3.1	1100	39.3	2.61	30.4	103.0	4.41	5.7	1100	40.6	27.4	0.68	2.09	47.7	19.4	3.0
				1400	40.2	2.63	31.3	96.6	4.49	5.3	1400	41.7	30.3	0.73	2.13	49.0	19.6	3.2
	8.0	3.2	7.4	1100	40.8	2.60	31.9	104.4	4.60	5.9	1100	41.0	27.6	0.67	2.04	47.9	20.1	2.8
				1400	41.8	2.62	32.9	97.6	4.68	5.4	1400	42.1	30.5	0.72	2.08	49.2	20.3	3.0
				1100	42.3	2.66	33.2	105.6	4.65	6.1	1100	41.6	28.3	0.68	2.02	48.5	20.6	2.6
			1400	43.2	2.68	34.1	98.6	4.73	5.6	1400	42.8	31.3	0.73	2.06	49.8	20.8	2.9	
70	5.0	1.3	3.0	1100	43.6	2.70	34.4	106.7	4.74	6.4	1100	39.3	27.3	0.70	2.27	47.0	17.3	3.8
				1400	44.3	2.71	35.1	99.3	4.79	6.0	1400	40.4	30.2	0.75	2.31	48.2	17.5	4.0
	8.0	3.1	7.2	1100	45.5	2.69	36.3	108.3	4.96	6.6	1100	39.6	27.5	0.69	2.21	47.2	18.0	3.5
				1400	46.3	2.69	37.2	100.7	5.06	6.1	1400	40.7	30.4	0.75	2.25	48.4	18.1	3.8
				1100	46.7	2.75	37.3	109.3	4.98	6.8	1100	40.3	28.2	0.70	2.19	47.7	18.4	3.3
			1400	47.5	2.74	38.2	101.4	5.08	6.3	1400	41.4	31.2	0.75	2.23	49.0	18.6	3.6	
80	5.0	1.2	2.9	1100	48.0	2.79	38.4	110.4	5.03	7.2	1100	37.7	26.7	0.71	2.50	46.2	15.1	4.8
				1400	48.6	2.78	39.1	102.2	5.13	6.7	1400	38.8	29.5	0.76	2.55	47.4	15.2	5.1
	8.0	3.0	6.9	1100	50.3	2.78	40.8	112.3	5.30	7.5	1100	38.1	26.8	0.71	2.43	46.4	15.6	4.5
				1400	50.9	2.76	41.5	103.6	5.41	6.9	1400	39.1	29.7	0.76	2.48	47.6	15.8	4.8
				1100	51.0	2.84	41.3	112.9	5.27	7.7	1100	38.7	27.5	0.71	2.41	46.9	16.0	4.1
			1400	51.5	2.81	41.9	104.1	5.37	7.1	1400	39.8	30.5	0.77	2.46	48.1	16.2	4.6	
90	5.0	1.2	2.8	1100	52.3	2.89	42.4	114.0	5.30	8.1	1100	36.1	26.0	0.72	2.73	45.5	13.2	6.0
				1400	52.7	2.86	43.0	104.9	5.41	7.5	1400	37.1	28.8	0.78	2.79	46.7	13.3	6.4
	8.0	2.9	6.7	1100	55.0	2.87	45.2	116.3	5.62	8.4	1100	36.5	26.2	0.72	2.66	45.6	13.7	5.6
				1400	55.4	2.83	45.7	106.6	5.74	7.8	1400	37.5	29.0	0.77	2.71	46.7	13.8	6.1
				1100	55.2	2.93	45.4	116.5	5.53	8.6	1100	37.3	26.5	0.71	2.51	45.9	14.9	5.2
			1400	55.5	2.88	45.7	106.7	5.65	8.0	1400	38.1	29.7	0.78	2.69	47.3	14.2	5.8	
100	5.0	1.2	2.7	Operation not recommended							Operation not recommended							
	8.0	2.8	6.4	Operation not recommended							1100	34.7	25.5	0.74	2.95	44.8	11.7	6.9
				Operation not recommended							1400	35.7	28.3	0.79	3.01	45.9	11.8	7.5
				Operation not recommended							1100	35.3	26.2	0.74	2.93	45.3	12.0	6.4
			Operation not recommended							1400	36.3	29.0	0.80	2.99	46.4	12.1	7.2	
110	5.0	1.1	2.6	Operation not recommended							Operation not recommended							
	8.0	2.7	6.2	Operation not recommended							1100	32.9	24.9	0.76	3.25	44.2	10.1	8.5
				Operation not recommended							1400	33.8	27.6	0.82	3.31	45.1	10.2	9.2
				Operation not recommended							1100	33.5	25.6	0.76	3.22	44.4	10.4	7.9
			Operation not recommended							1400	34.4	28.3	0.82	3.28	45.6	10.5	8.8	
120	5.0	1.1	2.5	Operation not recommended							Operation not recommended							
	8.0	2.6	5.9	Operation not recommended							1100	31.3	25.1	0.80	3.65	43.7	8.6	10.3
				Operation not recommended							1400	31.8	27.2	0.85	3.74	44.6	8.5	11.1
				Operation not recommended							1100	31.5	25.1	0.79	3.53	44.0	8.9	9.5
			Operation not recommended							1400	32.2	27.2	0.84	3.64	44.6	8.8	10.6	

Multiple Flow Rates (for EWT) are shown in the table above. The lowest flow rate shown is used for geothermal open loop/well water systems with a minimum 50° F. The second flow rate shown is the minimum geothermal closed loop flow rate. The third flow rate shown is optimum for geothermal closed loop and the suggested flow rate for boiler tower applications. 3/7/17

The manufacturer works continually to improve its products. As a result, the design and specifications of each product at the time of order may be changed without notice. Purchaser's approval of this data set signifies that the equipment is acceptable under the provisions of the job specification. Statements and other information contained herein are not express warranties and do not form the basis of any bargain between the parties, but are merely the manufacturer's opinion or commendation of its products. York and Affinity are registered trademarks of Johnson Controls, Inc., and are used with permission.



Contractor: \_\_\_\_\_ P.O.: \_\_\_\_\_  
 Engineer: \_\_\_\_\_  
 Project Name: \_\_\_\_\_ Unit Tag: \_\_\_\_\_

# Model 048 - Performance Data

## 048 - Single Speed

EWT °F	Flow gpm	WPD		HEATING - EAT 70°F							COOLING - EAT 80/67 °F							
		PSI	FT	Airflow cfm	HC Mbtu/h	Power kW	HE Mbtu/h	LAT °F	COP	HWC Mbtu/h	Airflow cfm	TC Mbtu/h	SC Mbtu/h	S/T Ratio	Power kW	HR Mbtu/h	EER	HWC Mbtu/h
20	6.0	1.3	3.0	Operation not recommended							Operation not recommended							
	9.0	2.8	6.5	Operation not recommended							Operation not recommended							
	12.0	4.3	9.8	1300	29.5	2.78	20.0	91.0	3.11	5.3								
				1500	29.8	2.80	20.2	88.4	3.12	4.8								
30	6.0	1.3	2.9	Operation not recommended							Operation not recommended							
	9.0	2.7	6.3	1300	34.3	2.72	25.0	94.4	3.69	5.6	1300	42.1	27.4	0.65	1.74	48.0	24.2	-
				1500	35.2	2.89	25.4	91.7	3.57	5.2	1500	42.7	29.9	0.70	1.83	49.0	23.3	-
	12.0	4.1	9.6	1300	35.2	2.90	25.3	95.1	3.56	5.8	1300	42.3	27.4	0.65	1.69	48.2	25.1	-
1500				35.6	2.92	25.6	92.0	3.57	5.3	1500	43.3	29.9	0.69	1.77	49.3	24.5	-	
40	6.0	1.2	2.9	Operation not recommended							Operation not recommended							
	9.0	2.6	6.1	1300	39.3	2.86	29.5	98.0	4.03	6.2	1300	45.7	30.2	0.66	1.91	52.2	23.9	-
				1500	40.2	2.98	30.0	94.8	3.95	5.7	1500	46.5	33.0	0.71	2.00	53.3	23.3	-
	12.0	4.0	9.3	1300	39.9	2.91	30.0	98.4	4.02	6.4	1300	46.0	30.2	0.66	1.85	52.3	24.9	-
1500				40.8	3.01	30.5	95.2	3.97	5.8	1500	47.1	33.0	0.70	1.94	53.7	24.3	-	
50	6.0	1.2	2.8	1300	41.9	2.94	31.9	99.8	4.18	6.7	1300	48.8	32.5	0.67	2.05	55.8	23.8	2.9
				1500	42.8	3.03	32.4	96.4	4.14	6.2	1500	49.8	35.3	0.71	2.18	57.3	22.8	3.1
	9.0	2.6	5.9	1300	44.3	2.99	34.1	101.6	4.34	6.9	1300	49.3	32.8	0.67	2.01	56.2	24.5	2.7
				1500	45.2	3.07	34.7	97.9	4.32	6.4	1500	50.3	35.7	0.71	2.13	57.6	23.6	2.9
12.0	3.9	9.0	1300	45.0	3.03	34.7	102.1	4.36	7.2	1300	49.8	33.2	0.67	1.98	56.5	25.2	2.5	
			1500	46.0	3.10	35.4	98.4	4.35	6.5	1500	50.8	36.0	0.71	2.10	58.0	24.2	2.8	
60	6.0	1.2	2.7	1300	46.5	3.05	36.1	103.1	4.47	7.6	1300	47.4	32.3	0.68	2.26	55.1	21.0	3.5
				1500	47.5	3.10	36.9	99.3	4.49	7.0	1500	48.6	35.1	0.72	2.40	56.8	20.2	3.7
	9.0	2.5	5.7	1300	48.6	3.10	38.1	104.6	4.60	7.8	1300	47.9	32.6	0.68	2.21	55.4	21.6	3.3
				1500	49.7	3.14	39.0	100.7	4.64	7.2	1500	49.1	35.5	0.72	2.35	57.2	20.9	3.6
12.0	3.8	8.7	1300	49.7	3.13	39.0	105.4	4.64	8.0	1300	48.4	33.0	0.68	2.18	55.8	22.2	3.0	
			1500	50.8	3.17	40.0	101.4	4.70	7.4	1500	49.6	35.8	0.72	2.32	57.5	21.4	3.4	
70	6.0	1.1	2.6	1300	51.1	3.16	40.3	106.4	4.74	8.5	1300	46.0	32.1	0.70	2.47	54.4	18.6	4.4
				1500	52.4	3.21	41.4	102.3	4.78	7.9	1500	47.4	34.9	0.74	2.63	56.4	18.1	4.7
	9.0	2.4	5.5	1300	53.0	3.20	42.1	107.7	4.85	8.8	1300	46.4	32.4	0.70	2.42	54.7	19.2	4.1
				1500	54.2	3.21	43.2	103.4	4.95	8.1	1500	47.9	35.2	0.73	2.57	56.7	18.6	4.5
12.0	3.6	8.4	1300	54.3	3.24	43.3	108.7	4.91	9.0	1300	46.9	32.7	0.70	2.38	55.0	19.7	3.8	
			1500	55.6	3.24	44.5	104.3	5.03	8.3	1500	48.4	35.6	0.74	2.53	57.0	19.1	4.2	
80	6.0	1.1	2.5	1300	55.5	3.30	44.3	109.6	4.93	9.6	1300	43.2	31.1	0.72	2.74	52.6	15.8	5.6
				1500	56.8	3.28	45.6	105.1	5.08	8.8	1500	44.8	33.8	0.75	2.92	54.8	15.3	5.9
	9.0	2.3	5.4	1300	56.9	3.34	45.5	110.5	4.99	9.8	1300	43.7	31.4	0.72	2.69	52.9	16.2	5.2
				1500	58.2	3.31	46.9	105.9	5.16	9.1	1500	45.3	34.1	0.75	2.86	55.1	15.8	5.6
12.0	3.5	8.1	1300	58.6	3.38	47.0	111.7	5.08	10.1	1300	44.1	31.7	0.72	2.64	53.1	16.7	4.8	
			1500	60.1	3.34	48.7	107.1	5.27	9.4	1500	45.8	34.5	0.75	2.82	55.4	16.3	5.4	
90	6.0	1.0	2.4	1300	60.0	3.44	48.2	112.7	5.11	10.7	1300	40.5	30.1	0.74	3.02	50.8	13.4	7.0
				1500	61.4	3.39	49.8	107.9	5.31	9.9	1500	42.2	32.7	0.77	3.22	53.2	13.1	7.4
	9.0	2.2	5.2	1300	60.8	3.48	48.9	113.3	5.12	11.1	1300	40.9	30.3	0.74	2.96	51.0	13.8	6.5
				1500	62.3	3.40	50.7	108.4	5.36	10.2	1500	42.6	33.0	0.77	3.15	53.4	13.5	7.1
12.0	3.4	7.8	1300	62.8	3.52	50.8	114.8	5.23	11.4	1300	41.2	30.5	0.74	3.02	51.5	13.6	6.1	
			1500	64.5	3.44	52.8	109.8	5.50	10.6	1500	43.1	33.3	0.77	3.10	53.7	13.9	6.7	
100	6.0	1.0	2.3	Operation not recommended							Operation not recommended							
	9.0	2.2	5.0	1300	37.0	29.3	0.79	3.31	48.3	11.2	8.1							
				1500	38.8	31.9	0.82	3.52	50.8	11.0	8.8							
	12.0	3.3	7.6	1300	37.4	29.7	0.79	3.25	48.4	11.5	7.5							
1500				39.2	32.2	0.82	3.47	51.0	11.3	8.4								
110	6.0	1.0	2.2	Operation not recommended							Operation not recommended							
	9.0	2.1	4.8	Operation not recommended							1300	33.1	28.3	0.86	3.65	45.6	9.1	9.9
				1500	34.9	30.7	0.88	3.89	48.2	9.0	10.8							
	12.0	3.1	7.3	Operation not recommended							1300	33.4	28.6	0.86	3.59	45.7	9.3	9.2
1500				35.2	31.1	0.88	3.83	48.3	9.2	10.2								
120	6.0	0.9	2.1	Operation not recommended							Operation not recommended							
	9.0	2.0	4.6	Operation not recommended							1300	34.6	27.6	0.80	4.27	49.2	8.1	12.0
				1500	35.3	30.0	0.85	4.38	50.2	8.1	13.0							
	12.0	3.0	7.0	Operation not recommended							1300	35.0	27.6	0.79	4.13	49.0	8.5	11.1
1500				35.7	30.0	0.84	4.26	50.2	8.4	12.4								

Multiple Flow Rates (for EWT) are shown in the table above. The lowest flow rate shown is used for geothermal open loop/well water systems with a minimum 50° F. The second flow rate shown is the minimum geothermal closed loop flow rate. The third flow rate shown is optimum for geothermal closed loop and the suggested flow rate for boiler tower applications.

3/7/17

The manufacturer works continually to improve its products. As a result, the design and specifications of each product at the time of order may be changed without notice. Purchaser's approval of this data set signifies that the equipment is acceptable under the provisions of the job specification. Statements and other information contained herein are not express warranties and do not form the basis of any bargain between the parties, but are merely the manufacturer's opinion or commendation of its products. York and Affinity are registered trademarks of Johnson Controls, Inc., and are used with permission.

Contractor: \_\_\_\_\_ P.O.: \_\_\_\_\_

Engineer: \_\_\_\_\_

Project Name: \_\_\_\_\_ Unit Tag: \_\_\_\_\_



# Model 060 - Performance Data

## 060 - Single Speed

EWT °F	Flow gpm	WPD		HEATING - EAT 70°F							COOLING - EAT 80/67 °F							
		PSI	FT	Airflow cfm	HC Mbtu/h	Power kW	HE Mbtu/h	LAT °F	COP	HWC Mbtu/h	Airflow cfm	TC Mbtu/h	SC Mbtu/h	S/T Ratio	Power kW	HR Mbtu/h	EER	HWC Mbtu/h
20	9.0	2.2	5.1	Operation not recommended							Operation not recommended							
	12.0	4.0	9.2	Operation not recommended							Operation not recommended							
	15.0	5.8	13.5	1500	40.5	3.88	27.2	95.0	3.05	6.5	Operation not recommended							
				2000	41.6	3.92	28.2	89.3	3.11	5.8	Operation not recommended							
30	9.0	2.1	4.9	Operation not recommended							Operation not recommended							
	12.0	3.9	8.9	1500	45.5	3.76	32.6	98.1	3.54	6.8	1500	54.0	33.1	0.61	2.46	62.4	22.0	-
				2000	46.7	4.00	33.0	91.6	3.42	6.2	2000	54.9	36.2	0.66	2.59	63.7	21.2	-
	15.0	5.7	13.1	1500	45.9	4.00	32.9	98.3	3.36	7.0	1500	54.3	33.1	0.61	2.38	62.6	22.8	-
				2000	47.2	4.04	33.4	91.9	3.42	6.4	2000	55.6	36.2	0.65	2.50	64.1	22.2	-
40	9.0	2.1	4.8	Operation not recommended							Operation not recommended							
	12.0	3.7	8.7	1500	51.6	3.97	38.0	101.8	3.81	7.5	1500	58.1	36.9	0.64	2.71	67.4	21.5	-
				2000	52.8	4.14	38.6	94.4	3.74	6.9	2000	59.2	40.3	0.68	2.84	68.9	20.8	-
	15.0	5.5	12.7	1500	52.4	4.04	38.6	102.3	3.80	7.8	1500	58.6	36.9	0.63	2.63	67.6	22.3	-
				2000	53.6	4.18	39.3	94.8	3.75	7.1	2000	59.9	40.3	0.67	2.75	69.3	21.8	-
50	9.0	2.0	4.6	1500	54.5	4.09	40.6	103.7	3.91	8.1	1500	61.7	40.1	0.65	2.93	71.7	21.0	3.9
				2000	55.7	4.22	41.3	95.8	3.87	7.5	2000	62.9	43.6	0.69	3.12	73.6	20.2	4.1
	12.0	3.6	8.4	1500	57.7	4.17	43.5	105.6	4.05	8.4	1500	62.3	40.4	0.65	2.87	72.1	21.7	3.6
				2000	58.8	4.27	44.3	97.2	4.03	7.7	2000	63.6	44.0	0.69	3.05	74.0	20.8	3.9
	15.0	5.3	12.3	1500	58.6	4.22	44.2	106.2	4.07	8.6	1500	62.9	40.9	0.65	2.82	72.6	22.3	3.4
2000				59.9	4.32	45.2	97.7	4.06	7.9	2000	64.2	44.4	0.69	3.00	74.4	21.4	3.7	
60	9.0	1.9	4.5	1500	60.2	4.27	45.7	107.2	4.13	9.1	1500	59.9	39.9	0.67	3.21	70.8	18.6	4.7
				2000	61.5	4.34	46.7	98.5	4.15	8.4	2000	61.4	43.4	0.71	3.42	73.1	18.0	5.0
	12.0	3.5	8.1	1500	63.0	4.34	48.2	108.9	4.25	9.4	1500	60.5	40.3	0.67	3.15	71.2	19.2	4.4
				2000	64.3	4.40	49.3	99.8	4.29	8.7	2000	62.1	43.8	0.71	3.34	73.5	18.6	4.8
	15.0	5.1	11.9	1500	64.3	4.39	49.4	109.7	4.30	9.7	1500	61.1	40.7	0.67	3.09	71.6	19.7	4.1
2000				65.8	4.44	50.7	100.5	4.34	8.9	2000	62.7	44.3	0.71	3.29	73.9	19.0	4.6	
70	9.0	1.9	4.3	1500	65.9	4.44	50.7	110.7	4.35	10.3	1500	58.1	39.8	0.69	3.49	70.0	16.6	5.9
				2000	68.9	4.53	53.4	101.9	4.46	9.5	2000	59.9	43.2	0.72	3.72	72.6	16.1	6.3
	12.0	3.4	7.9	1500	68.3	4.51	52.9	112.2	4.44	10.6	1500	58.6	40.2	0.69	3.42	70.3	17.1	5.5
				2000	69.9	4.52	54.4	102.3	4.53	9.8	2000	60.5	43.6	0.72	3.64	72.9	16.6	6.0
	15.0	5.0	11.5	1500	70.1	4.56	54.5	113.2	4.50	10.9	1500	59.2	40.6	0.69	3.36	70.7	17.6	5.1
2000				71.7	4.56	56.1	103.2	4.61	10.0	2000	61.1	44.1	0.72	3.58	73.3	17.1	5.7	
80	9.0	1.8	4.2	1500	71.2	4.63	55.4	113.9	4.50	11.5	1500	54.9	38.4	0.70	3.85	68.0	14.2	7.5
				2000	72.8	4.61	57.1	103.7	4.63	10.7	2000	56.9	41.7	0.73	4.11	70.9	13.9	8.0
	12.0	3.3	7.6	1500	72.9	4.69	56.9	115.0	4.55	11.9	1500	55.5	38.7	0.70	3.78	68.4	14.7	7.0
				2000	74.6	4.64	58.8	104.5	4.71	11.0	2000	57.5	42.1	0.73	4.02	71.2	14.3	7.6
	15.0	4.8	11.1	1500	75.1	4.75	58.9	116.3	4.63	12.2	1500	56.0	39.1	0.70	3.71	68.7	15.1	6.5
2000				77.0	4.69	60.9	105.6	4.81	11.3	2000	58.1	42.5	0.73	3.96	71.6	14.7	7.2	
90	9.0	1.8	4.0	1500	76.4	4.82	60.0	117.2	4.65	13.0	1500	51.7	36.9	0.71	4.22	66.1	12.3	9.4
				2000	78.3	4.75	62.1	106.2	4.83	12.0	2000	54.0	40.1	0.74	4.49	69.3	12.0	10.0
	12.0	3.2	7.3	1500	77.4	4.87	60.8	117.8	4.66	13.4	1500	52.3	37.2	0.71	4.14	66.4	12.6	8.8
				2000	79.4	4.77	63.1	106.7	4.88	12.4	2000	54.5	40.5	0.74	4.40	69.5	12.4	9.5
	15.0	4.6	10.7	1500	80.1	4.93	63.3	119.4	4.76	13.8	1500	54.4	37.3	0.69	4.03	68.2	13.5	8.2
2000				82.2	4.82	65.8	108.1	5.00	12.8	2000	55.1	40.9	0.74	4.33	69.9	12.7	9.1	
100	9.0	1.7	3.9	Operation not recommended							Operation not recommended							
	12.0	3.1	7.1	1500	49.4	36.2	0.73	4.61	65.2	10.7	10.9	Operation not recommended						
				2000	51.8	39.3	0.76	4.92	68.6	10.5	11.8	Operation not recommended						
	15.0	4.5	10.3	1500	49.9	36.6	0.73	4.53	65.4	11.0	10.1	Operation not recommended						
2000				52.3	39.8	0.76	4.84	68.8	10.8	11.2	Operation not recommended							
110	9.0	1.6	3.8	Operation not recommended							Operation not recommended							
	12.0	2.9	6.8	Operation not recommended							1500	46.6	35.2	0.76	5.09	63.9	9.1	13.4
				2000	49.1	38.2	0.78	5.43	67.6	9.0	14.5	Operation not recommended						
	15.0	4.3	9.9	Operation not recommended							1500	47.0	35.5	0.76	5.00	64.1	9.4	12.4
2000				49.5	38.6	0.78	5.34	67.7	9.3	13.8	Operation not recommended							
120	9.0	1.6	3.6	Operation not recommended							Operation not recommended							
	12.0	2.8	6.5	Operation not recommended							1500	44.2	33.7	0.76	5.97	64.5	7.4	16.1
				2000	45.0	36.6	0.81	6.13	65.9	7.3	17.5	Operation not recommended						
	15.0	4.1	9.6	Operation not recommended							1500	44.6	33.7	0.76	5.78	64.3	7.7	15.0
2000				45.5	36.6	0.80	5.96	65.8	7.6	16.7	Operation not recommended							

Multiple Flow Rates (for EWT) are shown in the table above. The lowest flow rate shown is used for geothermal open loop/well water systems with a minimum 50° F. The second flow rate shown is the minimum geothermal closed loop flow rate. The third flow rate shown is optimum for geothermal closed loop and the suggested flow rate for boiler tower applications.

3/7/17

The manufacturer works continually to improve its products. As a result, the design and specifications of each product at the time of order may be changed without notice. Purchaser's approval of this data set signifies that the equipment is acceptable under the provisions of the job specification. Statements and other information contained herein are not express warranties and do not form the basis of any bargain between the parties, but are merely the manufacturer's opinion or commendation of its products. York and Affinity are registered trademarks of Johnson Controls, Inc., and are used with permission.

Contractor: \_\_\_\_\_ P.O.: \_\_\_\_\_

Engineer: \_\_\_\_\_

Project Name: \_\_\_\_\_ Unit Tag: \_\_\_\_\_

**Affinity Single & Dual Capacity  
Indoor Split Series  
2 - 6 Tons 60Hz**



# Model 070 - Performance Data

## 070 - Single Speed

EWT °F	Flow gpm	WPD		HEATING - EAT 70°F							COOLING - EAT 80/67 °F							
		PSI	FT	Airflow cfm	HC Mbtu/h	Power kW	HE Mbtu/h	LAT °F	COP	HWC Mbtu/h	Airflow cfm	TC Mbtu/h	SC Mbtu/h	S/T Ratio	Power kW	HR Mbtu/h	EER	HWC Mbtu/h
20	12.0	3.4	7.8	Operation not recommended							Operation not recommended							
	15.0	5.1	11.9	Operation not recommended							Operation not recommended							
	18.0	6.9	16.0	1700	44.5	4.44	29.4	94.3	2.94	7.7	Operation not recommended							
				2100	45.9	4.50	30.5	90.2	2.99	6.9	Operation not recommended							
30	12.0	3.3	7.6	Operation not recommended							Operation not recommended							
	15.0	5.0	11.6	1700	51.9	4.41	36.8	98.3	3.45	8.1	1700	57.4	34.0	0.59	2.87	67.2	20.0	-
				2100	53.3	4.70	37.3	93.5	3.33	7.4	2100	58.3	37.2	0.64	3.02	68.6	19.3	-
	18.0	6.7	15.6	1700	52.3	4.68	37.2	98.5	3.28	8.4	1700	57.7	34.0	0.59	2.78	67.6	20.7	-
2100				53.9	4.74	37.7	93.8	3.33	7.6	2100	59.1	37.2	0.63	2.92	69.1	20.2	-	
40	12.0	3.2	7.4	Operation not recommended							Operation not recommended							
	15.0	4.8	11.2	1700	59.0	4.68	43.1	102.2	3.70	8.9	1700	62.6	38.7	0.62	3.14	73.3	19.9	-
				2100	60.4	4.88	43.7	96.6	3.63	8.2	2100	63.7	42.2	0.66	3.30	75.0	19.3	-
	18.0	6.5	15.1	1700	59.9	4.76	43.7	102.6	3.69	9.2	1700	63.0	38.7	0.61	3.05	73.4	20.7	-
2100				61.3	4.93	44.5	97.0	3.64	8.4	2100	64.5	42.2	0.65	3.19	75.3	20.2	-	
50	12.0	3.1	7.1	1700	62.5	4.85	46.0	104.1	3.78	9.7	1700	67.1	42.6	0.64	3.38	78.6	19.8	4.3
				2100	63.9	5.00	46.8	98.2	3.74	8.9	2100	68.4	46.3	0.68	3.60	80.7	19.0	4.5
	15.0	4.7	10.9	1700	66.2	4.94	49.3	106.0	3.92	10.0	1700	67.8	43.0	0.63	3.31	79.1	20.5	4.0
				2100	67.5	5.07	50.2	99.8	3.90	9.2	2100	69.1	46.8	0.68	3.52	81.1	19.7	4.3
18.0	6.3	14.6	1700	67.2	5.00	50.2	106.6	3.94	10.3	1700	68.4	43.5	0.64	3.26	79.5	21.0	3.7	
			2100	68.7	5.12	51.2	100.3	3.93	9.4	2100	69.8	47.2	0.68	3.46	81.6	20.2	4.1	
60	12.0	3.0	6.9	1700	69.6	5.10	52.2	107.9	4.00	10.8	1700	66.3	42.3	0.64	3.68	78.9	18.0	5.2
				2100	71.1	5.18	53.4	101.3	4.02	10.0	2100	68.0	46.0	0.68	3.92	81.4	17.3	5.5
	15.0	4.5	10.5	1700	72.8	5.18	55.1	109.6	4.11	11.2	1700	67.0	42.7	0.64	3.61	79.3	18.5	4.8
				2100	74.3	5.25	56.4	102.8	4.15	10.3	2100	68.7	46.4	0.68	3.84	81.8	17.9	5.2
18.0	6.1	14.2	1700	74.3	5.24	56.4	110.5	4.16	11.5	1700	67.6	43.1	0.64	3.55	79.7	19.0	4.5	
			2100	76.0	5.30	57.9	103.5	4.20	10.6	2100	69.4	46.9	0.68	3.78	82.2	18.4	5.0	
70	12.0	2.9	6.7	1700	76.6	5.34	58.3	111.7	4.20	12.2	1700	65.5	42.0	0.64	3.99	79.1	16.4	6.5
				2100	80.4	5.42	61.9	105.4	4.35	11.3	2100	67.5	45.6	0.68	4.25	82.0	15.9	6.9
	15.0	4.4	10.2	1700	79.4	5.42	60.9	113.2	4.29	12.6	1700	66.1	42.4	0.64	3.91	79.5	16.9	6.1
				2100	81.2	5.43	62.6	105.8	4.38	11.6	2100	68.3	46.0	0.67	4.16	82.4	16.4	6.6
18.0	5.9	13.7	1700	81.4	5.48	62.7	114.3	4.35	13.0	1700	66.8	42.8	0.64	3.84	79.9	17.4	5.6	
			2100	83.3	5.48	64.6	106.7	4.46	11.9	2100	68.9	46.5	0.67	4.09	82.9	16.8	6.3	
80	12.0	2.8	6.5	1700	82.3	5.57	63.3	114.8	4.33	13.7	1700	60.3	22.9	0.38	4.39	75.2	13.7	8.2
				2100	84.2	5.54	65.3	107.1	4.46	12.7	2100	62.5	24.9	0.40	4.67	78.5	13.4	8.7
	15.0	4.3	9.8	1700	84.3	5.64	65.0	115.9	4.38	14.1	1700	60.9	23.1	0.38	4.30	75.6	14.2	7.7
				2100	86.3	5.58	67.2	108.0	4.53	13.1	2100	63.2	25.1	0.40	4.57	78.8	13.8	8.3
18.0	5.7	13.2	1700	86.8	5.70	67.4	117.3	4.46	14.6	1700	61.5	23.4	0.38	4.23	75.9	14.6	7.1	
			2100	89.0	5.64	69.8	109.2	4.63	13.5	2100	63.8	25.4	0.40	4.50	79.2	14.2	7.9	
90	12.0	2.7	6.2	1700	88.0	5.79	68.3	118.0	4.46	15.4	1700	55.1	3.8	0.07	4.78	71.4	11.5	10.3
				2100	90.2	5.70	70.7	109.8	4.63	14.3	2100	57.5	4.2	0.07	5.10	74.9	11.3	10.9
	15.0	4.1	9.5	1700	89.2	5.85	69.2	118.6	4.47	15.9	1700	55.7	3.9	0.07	4.69	71.7	11.9	9.6
				2100	91.4	5.73	71.9	110.3	4.68	14.7	2100	58.1	4.2	0.07	4.99	75.1	11.6	10.4
18.0	5.5	12.8	1700	92.3	5.92	72.1	120.3	4.56	16.4	1700	58.3	40.1	0.69	4.66	74.2	12.5	8.9	
			2100	94.7	5.79	74.9	111.8	4.79	15.2	2100	58.7	4.2	0.07	4.91	75.5	12.0	9.9	
100	12.0	2.6	6.0	Operation not recommended							Operation not recommended							
	15.0	4.0	9.1	1700	52.8	20.2	0.38	5.19	70.5	10.2	12.0	Operation not recommended						
				2100	55.2	21.9	0.40	5.53	74.1	10.0	13.0	Operation not recommended						
	18.0	5.3	12.3	1700	53.3	20.4	0.38	5.10	70.7	10.4	11.1	Operation not recommended						
2100				55.8	22.2	0.40	5.44	74.4	10.3	12.3	Operation not recommended							
110	12.0	2.5	5.8	Operation not recommended							Operation not recommended							
	15.0	3.8	8.8	Operation not recommended							1700	49.8	36.5	0.73	5.69	69.2	8.7	14.6
				2100	52.4	39.6	0.76	6.07	73.1	8.6	15.9	Operation not recommended						
	18.0	5.1	11.8	Operation not recommended							1700	50.2	36.9	0.73	5.59	69.4	9.0	13.6
2100				52.9	40.1	0.76	5.97	73.3	8.9	15.1	Operation not recommended							
120	12.0	2.4	5.5	Operation not recommended							Operation not recommended							
	15.0	3.7	8.4	Operation not recommended							1700	47.5	35.2	0.74	6.59	70.0	7.2	17.7
				2100	48.3	38.2	0.79	6.76	71.4	7.1	19.2	Operation not recommended						
	18.0	4.9	11.4	Operation not recommended							1700	47.9	35.2	0.73	6.38	69.6	7.5	16.4
2100				48.9	38.2	0.78	6.58	71.4	7.4	18.2	Operation not recommended							

Multiple Flow Rates (for EWT) are shown in the table above. The lowest flow rate shown is used for geothermal open loop/well water systems with a minimum 50° F. The second flow rate shown is the minimum geothermal closed loop flow rate. The third flow rate shown is optimum for geothermal closed loop and the suggested flow rate for boiler tower applications. 3/7/17

The manufacturer works continually to improve its products. As a result, the design and specifications of each product at the time of order may be changed without notice. Purchaser's approval of this data set signifies that the equipment is acceptable under the provisions of the job specification. Statements and other information contained herein are not express warranties and do not form the basis of any bargain between the parties, but are merely the manufacturer's opinion or commendation of its products. York and Affinity are registered trademarks of Johnson Controls, Inc., and are used with permission.

Contractor: \_\_\_\_\_ P.O.: \_\_\_\_\_

Engineer: \_\_\_\_\_

Project Name: \_\_\_\_\_ Unit Tag: \_\_\_\_\_

**Affinity Single & Dual Capacity  
Indoor Split Series  
2 - 6 Tons 60Hz**



# Model 026 Low Speed - Performance Data

## 026 - Dual Capacity Low Speed

EWT °F	Flow gpm	WPD		HEATING - EAT 70°F							COOLING - EAT 80/67 °F							
		PSI	FT	Airflow cfm	HC Mbtu/h	Power kW	HE Mbtu/h	LAT °F	COP	HWC Mbtu/h	Airflow cfm	TC Mbtu/h	SC Mbtu/h	S/T Ratio	Power kW	HR Mbtu/h	EER	HWC Mbtu/h
20	3.0	1.0	2.3	Operation not recommended							Operation not recommended							
	5.0	2.6	5.9	Operation not recommended							Operation not recommended							
	7.0	4.0	9.2	500	11.7	1.22	7.6	91.7	2.82	1.8	Operation not recommended							
				700	11.9	1.17	7.9	85.7	2.98	1.6	Operation not recommended							
30	3.0	1.0	2.3	Operation not recommended							Operation not recommended							
	5.0	2.5	5.8	500	12.5	1.12	8.7	93.2	3.28	1.8	500	17.2	10.2	0.60	0.63	19.3	27.4	-
				700	13.1	1.15	9.1	87.3	3.32	1.6	700	17.5	11.2	0.64	0.66	19.7	26.4	-
	7.0	3.9	8.9	500	13.7	1.23	9.5	95.4	3.26	1.8	500	17.3	10.2	0.59	0.61	19.4	28.3	-
				700	13.9	1.18	9.9	88.4	3.45	1.6	700	17.7	11.2	0.63	0.64	19.9	27.7	-
	40	3.0	1.0	2.2	Operation not recommended							Operation not recommended						
5.0		2.4	5.6	500	14.9	1.14	11.0	97.5	3.80	1.8	500	18.6	12.3	0.66	0.68	21.0	27.2	-
				700	15.4	1.17	11.4	90.3	3.86	1.7	700	19.0	13.5	0.71	0.72	21.4	26.4	-
7.0		3.7	8.7	500	15.7	1.17	11.7	99.0	3.91	1.9	500	18.8	12.3	0.66	0.66	21.0	28.3	-
	700			16.2	1.20	12.1	91.4	3.97	1.7	700	19.2	13.5	0.70	0.70	21.6	27.6	-	
50	3.0	0.9	2.1	500	16.6	1.17	12.6	100.7	4.16	1.9	500	19.6	13.8	0.70	0.76	22.2	25.8	0.7
				700	17.1	1.18	13.1	92.6	4.23	1.7	700	20.2	15.2	0.75	0.78	22.8	26.0	0.8
	5.0	2.3	5.4	500	17.2	1.17	13.2	101.8	4.31	1.9	500	19.8	13.8	0.70	0.74	22.3	26.7	0.7
				700	17.7	1.18	13.6	93.4	4.38	1.8	700	20.4	15.3	0.75	0.76	22.9	26.9	0.7
	7.0	3.6	8.4	500	18.0	1.20	13.9	103.3	4.40	2.0	500	20.1	14.2	0.70	0.74	22.7	27.4	0.6
				700	18.5	1.21	14.4	94.5	4.48	1.8	700	20.7	15.7	0.76	0.75	23.3	27.6	0.7
60	3.0	0.9	2.1	500	18.8	1.19	14.7	104.7	4.60	2.1	500	19.1	13.6	0.71	0.86	22.1	22.1	1.0
				700	19.2	1.20	15.1	95.4	4.68	1.9	700	19.6	15.1	0.77	0.88	22.6	22.3	1.0
	5.0	2.3	5.3	500	19.5	1.19	15.4	106.1	4.80	2.1	500	19.3	13.7	0.71	0.84	22.2	22.9	0.9
				700	20.0	1.20	15.9	96.4	4.88	2.0	700	19.8	15.2	0.76	0.86	22.7	23.1	1.0
	7.0	3.5	8.1	500	20.2	1.22	16.0	107.4	4.86	2.2	500	19.6	14.0	0.72	0.83	22.5	23.5	0.8
				700	20.7	1.23	16.5	97.3	4.94	2.0	700	20.2	15.6	0.77	0.85	23.1	23.7	0.9
70	3.0	0.9	2.0	500	20.9	1.22	16.8	108.8	5.02	2.3	500	18.6	13.5	0.73	0.97	21.9	19.3	1.3
				700	21.3	1.22	17.2	98.2	5.12	2.1	700	19.1	14.9	0.78	0.98	22.5	19.4	1.4
	5.0	2.2	5.1	500	21.8	1.22	17.7	110.5	5.26	2.4	500	18.8	13.6	0.72	0.94	22.0	20.0	1.3
				700	22.2	1.22	18.1	99.4	5.37	2.2	700	19.3	15.0	0.78	0.96	22.6	20.1	1.4
	7.0	3.4	7.9	500	22.4	1.24	18.2	111.5	5.29	2.4	500	19.1	13.9	0.73	0.93	22.3	20.5	1.2
				700	22.8	1.24	18.6	100.2	5.39	2.2	700	19.6	15.4	0.79	0.95	22.8	20.6	1.3
80	3.0	0.8	1.9	500	23.1	1.25	18.8	112.8	5.42	2.6	500	17.2	12.1	0.70	1.09	20.9	15.7	1.8
				700	23.4	1.24	19.2	101.0	5.53	2.4	700	17.6	13.4	0.76	1.11	21.4	15.9	1.9
	5.0	2.1	4.9	500	24.2	1.24	20.0	114.8	5.72	2.6	500	17.3	12.2	0.70	1.06	21.0	16.3	1.7
				700	24.5	1.23	20.3	102.4	5.83	2.4	700	17.8	13.5	0.76	1.08	21.5	16.4	1.9
	7.0	3.3	7.6	500	24.5	1.27	20.2	115.5	5.68	2.7	500	17.6	12.5	0.71	1.05	21.2	16.7	1.6
				700	24.8	1.26	20.5	102.8	5.79	2.5	700	18.1	13.8	0.76	1.08	21.8	16.8	1.8
90	3.0	0.8	1.9	500	25.3	1.28	20.9	116.8	5.80	2.9	500	15.7	10.7	0.68	1.22	19.9	12.9	2.4
				700	25.5	1.26	21.2	103.7	5.92	2.7	700	16.2	11.8	0.73	1.24	20.4	13.0	2.6
	5.0	2.0	4.7	500	26.6	1.27	22.2	119.2	6.15	3.0	500	15.9	10.7	0.68	1.19	20.1	13.4	2.3
				700	26.7	1.25	22.5	105.4	6.28	2.8	700	16.3	11.9	0.73	1.21	20.5	13.5	2.5
	7.0	3.2	7.3	500	26.7	1.29	22.3	119.4	6.06	3.1	500	16.2	11.0	0.68	1.18	20.2	13.7	2.1
				700	26.8	1.27	22.5	105.4	6.18	2.8	700	16.6	12.2	0.73	1.20	20.7	13.8	2.4
100	3.0	0.8	1.8	Operation not recommended							Operation not recommended							
	5.0	2.0	4.6	500	14.9	1.15	0.77	1.38	19.6	10.8	3.0	Operation not recommended						
				700	15.3	1.27	0.83	1.41	20.1	10.9	3.2	Operation not recommended						
	7.0	3.1	7.1	500	15.1	1.18	0.78	1.37	19.8	11.1	2.8	Operation not recommended						
700				15.6	1.31	0.84	1.40	20.3	11.1	3.1	Operation not recommended							
110	3.0	0.7	1.7	Operation not recommended							Operation not recommended							
	5.0	1.9	4.4	500	13.9	1.22	0.88	1.57	19.2	8.8	3.8	Operation not recommended						
				700	14.3	1.36	0.95	1.60	19.7	8.9	4.1	Operation not recommended						
	7.0	2.9	6.8	500	14.1	1.26	0.89	1.56	19.4	9.0	3.5	Operation not recommended						
700				14.5	1.39	0.96	1.59	19.9	9.1	3.9	Operation not recommended							
120	3.0	0.7	1.7	Operation not recommended							Operation not recommended							
	5.0	1.8	4.2	500	13.1	1.22	0.93	1.81	19.3	7.2	4.7	Operation not recommended						
				700	13.3	1.32	0.99	1.86	19.7	7.2	5.1	Operation not recommended						
	7.0	2.8	6.5	500	13.2	1.22	0.92	1.75	19.2	7.5	4.3	Operation not recommended						
700				13.5	1.32	0.98	1.81	19.7	7.5	4.8	Operation not recommended							

Multiple Flow Rates (for EWT) are shown in the table above. The lowest flow rate shown is used for geothermal open loop/well water systems with a minimum 50° F. The second flow rate shown is the minimum geothermal closed loop flow rate. The third flow rate shown is optimum for geothermal closed loop and the suggested flow rate for boiler tower applications. 3/7/17

The manufacturer works continually to improve its products. As a result, the design and specifications of each product at the time of order may be changed without notice. Purchaser's approval of this data set signifies that the equipment is acceptable under the provisions of the job specification. Statements and other information contained herein are not express warranties and do not form the basis of any bargain between the parties, but are merely the manufacturer's opinion or commendation of its products. York and Affinity are registered trademarks of Johnson Controls, Inc., and are used with permission.

Contractor: \_\_\_\_\_ P.O.: \_\_\_\_\_

Engineer: \_\_\_\_\_

Project Name: \_\_\_\_\_ Unit Tag: \_\_\_\_\_

**Affinity Single & Dual Capacity  
Indoor Split Series  
2 - 6 Tons 60Hz**



## Model 026 High Speed - Performance Data

### 026 - Dual Capacity High Speed

EWT °F	Flow gpm	WPD		HEATING - EAT 70°F							COOLING - EAT 80/67 °F								
		PSI	FT	Airflow cfm	HC Mbtu/h	Power kW	HE Mbtu/h	LAT °F	COP	HWC Mbtu/h	Airflow cfm	TC Mbtu/h	SC Mbtu/h	S/T Ratio	Power kW	HR Mbtu/h	EER	HWC Mbtu/h	
20	4.0	1.4	3.2	Operation not recommended							Operation not recommended								
	6.0	3.4	7.8	Operation not recommended							Operation not recommended								
	8.0	5.3	12.2	700	16.0	1.49	10.9	91.1	3.14	2.1	Operation not recommended								
30	8.0	16.4	1.50	11.3	86.9	3.20	2.0	Operation not recommended											
	4.0	1.4	3.2	Operation not recommended							Operation not recommended								
	6.0	3.3	7.6	700	18.2	1.50	13.1	94.1	3.56	2.3	700	23.0	14.0	0.61	1.00	26.4	23.0	-	
	900	18.7	1.54	13.5	89.3	3.55	2.1	900	23.4	15.3	0.65	1.06	27.0	22.2	-				
40	8.0	5.1	11.8	700	18.6	1.55	13.3	94.6	3.52	2.3	700	23.1	14.0	0.61	0.97	26.5	23.8	-	
	900	19.1	1.56	13.8	89.7	3.59	2.2	900	23.7	15.3	0.65	1.02	27.2	23.2	-				
	4.0	1.3	3.1	Operation not recommended							Operation not recommended								
	6.0	3.2	7.4	700	20.9	1.57	15.5	97.6	3.90	2.5	700	25.0	16.4	0.66	1.10	28.8	22.6	-	
50	900	21.5	1.60	16.0	92.1	3.94	2.3	900	25.5	17.9	0.70	1.16	29.4	22.0	-				
	8.0	5.0	11.5	700	21.3	1.58	15.9	98.1	3.94	2.6	700	25.2	16.4	0.65	1.07	28.8	23.5	-	
	900	22.0	1.62	16.4	92.6	3.98	2.4	900	25.8	17.9	0.70	1.12	29.6	23.0	-				
	4.0	1.3	3.0	700	22.7	1.60	17.2	100.0	4.16	2.7	700	25.6	17.1	0.67	1.26	29.9	20.3	1.3	
60	900	23.4	1.62	17.8	94.0	4.23	2.5	900	26.9	19.0	0.71	1.33	31.5	20.3	1.4				
	6.0	3.1	7.2	700	23.5	1.63	17.9	101.1	4.22	2.8	700	26.2	17.3	0.66	1.19	30.2	22.0	1.3	
	900	24.3	1.66	18.6	95.0	4.30	2.6	900	27.5	19.2	0.70	1.25	31.8	22.0	1.4				
	8.0	4.8	11.1	700	24.0	1.65	18.4	101.8	4.28	2.9	700	26.4	18.5	0.70	1.16	30.4	22.7	1.2	
70	900	24.8	1.67	19.1	95.5	4.35	2.7	900	27.8	20.5	0.74	1.22	32.0	22.8	1.3				
	4.0	1.2	2.9	700	25.0	1.67	19.3	103.0	4.39	3.1	700	25.0	17.2	0.69	1.38	29.7	18.1	1.6	
	6.0	3.0	6.9	900	25.8	1.68	20.0	96.5	4.50	2.9	900	26.2	19.1	0.73	1.44	31.1	18.2	1.7	
	900	26.1	1.71	20.2	104.5	4.46	3.2	700	25.6	17.4	0.68	1.31	30.0	19.5	1.5				
80	8.0	4.7	10.8	900	26.9	1.73	21.0	97.7	4.57	2.9	900	26.8	19.3	0.72	1.36	31.4	19.6	1.6	
	700	26.7	1.73	20.8	105.3	4.52	3.3	700	25.8	18.3	0.71	1.28	30.2	20.2	1.4				
	900	27.6	1.74	21.7	98.4	4.65	3.0	700	27.1	20.3	0.75	1.34	31.7	20.3	1.6				
	4.0	1.2	2.8	700	27.3	1.74	21.3	106.1	4.60	3.5	700	24.4	17.2	0.71	1.49	29.5	16.3	2.0	
90	900	28.6	1.81	22.4	99.4	4.63	3.2	900	25.5	19.2	0.75	1.55	30.7	16.4	2.1				
	6.0	2.9	6.7	700	28.7	1.80	22.5	107.9	4.68	3.6	700	25.0	17.4	0.70	1.43	29.9	17.5	1.9	
	900	29.6	1.80	23.5	100.5	4.83	3.3	900	26.1	19.3	0.74	1.48	31.1	17.6	2.0				
	8.0	4.5	10.4	700	29.4	1.82	23.2	108.9	4.74	3.7	700	25.3	18.1	0.72	1.39	30.0	18.1	1.7	
100	900	30.4	1.81	24.2	101.3	4.92	3.4	900	26.4	20.1	0.76	1.45	31.3	18.2	1.9				
	4.0	1.2	2.7	700	29.5	1.81	23.3	109.0	4.77	3.9	700	22.8	17.1	0.75	1.65	28.4	13.8	2.5	
	6.0	2.8	6.5	900	30.5	1.80	24.4	101.4	4.98	3.6	900	23.7	19.1	0.80	1.70	29.5	14.0	2.7	
	900	31.2	1.88	24.8	111.3	4.85	4.0	700	23.4	17.4	0.74	1.59	28.9	14.7	2.3				
110	900	32.3	1.87	25.9	103.2	5.07	3.7	900	24.4	19.2	0.79	1.64	30.0	14.9	2.5				
	8.0	4.3	10.0	700	32.1	1.91	25.6	112.5	4.93	4.1	700	23.7	17.8	0.75	1.56	29.0	15.2	2.2	
	900	33.2	1.88	26.8	104.2	5.18	3.8	900	24.7	19.7	0.80	1.61	30.1	15.4	2.4				
	4.0	1.1	2.6	700	31.7	1.89	25.3	112.0	4.93	4.3	700	21.2	17.1	0.80	1.80	27.4	11.8	3.1	
120	900	32.9	1.86	26.5	103.8	5.19	4.0	900	22.0	18.9	0.86	1.85	28.3	11.9	3.3				
	6.0	2.7	6.2	700	33.7	1.97	27.0	114.6	5.02	4.5	700	21.8	17.3	0.79	1.75	27.8	12.5	2.9	
	900	34.9	1.94	28.3	105.9	5.29	4.1	900	22.6	19.2	0.85	1.80	28.8	12.6	3.2				
	8.0	4.2	9.7	700	34.8	2.00	28.0	116.0	5.10	4.6	700	22.2	17.1	0.77	1.66	27.9	13.4	2.7	
130	900	36.0	1.95	29.3	107.0	5.41	4.3	900	22.9	19.3	0.84	1.76	28.9	13.0	3.0				
	4.0	1.1	2.5	Operation not recommended							Operation not recommended								
	6.0	2.6	6.0	Operation not recommended							Operation not recommended								
	8.0	4.0	9.3	700	20.8	16.9	0.81	1.96	27.5	10.6	3.6	900	21.5	18.8	0.87	1.99	28.3	10.8	3.9
140	900	21.1	16.9	0.80	1.93	27.7	10.9	3.3	700	21.1	16.9	0.80	1.93	27.7	10.9	3.3			
	4.0	1.0	2.4	Operation not recommended							Operation not recommended								
	6.0	2.5	5.8	Operation not recommended							Operation not recommended								
	8.0	3.9	9.0	700	19.9	16.5	0.83	2.18	27.3	9.1	4.4	900	20.4	18.4	0.90	2.19	27.9	9.3	4.7
150	900	20.1	16.3	0.81	2.14	27.6	9.4	4.1	700	20.1	16.3	0.81	2.14	27.6	9.4	4.1			
	4.0	1.0	2.3	Operation not recommended							Operation not recommended								
	6.0	2.4	5.6	Operation not recommended							Operation not recommended								
	8.0	3.7	8.6	700	20.6	18.0	0.87	2.16	28.0	9.5	4.5	900	20.6	18.0	0.87	2.16	28.0	9.5	4.5
160	4.0	1.0	2.3	Operation not recommended							Operation not recommended								
	6.0	2.4	5.6	Operation not recommended							Operation not recommended								
	8.0	3.7	8.6	700	17.9	16.2	0.91	2.40	26.1	7.4	5.3	900	18.2	17.6	0.97	2.47	26.6	7.4	5.7
	900	18.0	16.2	0.90	2.33	26.0	7.7	4.9	700	18.0	16.2	0.90	2.33	26.0	7.7	4.9			
900	18.4	17.6	0.96	2.40	26.6	7.7	5.4	900	18.4	17.6	0.96	2.40	26.6	7.7	5.4				

Multiple Flow Rates (for EWT) are shown in the table above. The lowest flow rate shown is used for geothermal open loop/well water systems with a minimum 50° F. The second flow rate shown is the minimum geothermal closed loop flow rate. The third flow rate shown is optimum for geothermal closed loop and the suggested flow rate for boiler tower applications. 3/7/17

The manufacturer works continually to improve its products. As a result, the design and specifications of each product at the time of order may be changed without notice. Purchaser's approval of this data set signifies that the equipment is acceptable under the provisions of the job specification. Statements and other information contained herein are not express warranties and do not form the basis of any bargain between the parties, but are merely the manufacturer's opinion or commendation of its products. York and Affinity are registered trademarks of Johnson Controls, Inc., and are used with permission.



Contractor: \_\_\_\_\_ P.O.: \_\_\_\_\_

Engineer: \_\_\_\_\_

Project Name: \_\_\_\_\_ Unit Tag: \_\_\_\_\_



# Model 038 Low Speed - Performance Data

## 038 - Dual Capacity Low Speed

EWT °F	Flow gpm	WPD		HEATING - EAT 70°F							COOLING - EAT 80/67 °F							
		PSI	FT	Airflow cfm	HC Mbtu/h	Power kW	HE Mbtu/h	LAT °F	COP	HWC Mbtu/h	Airflow cfm	TC Mbtu/h	SC Mbtu/h	S/T Ratio	Power kW	HR Mbtu/h	EER	HWC Mbtu/h
20	4.0	1.0	2.2	Operation not recommended							Operation not recommended							
	6.0	2.1	4.9	Operation not recommended							Operation not recommended							
	8.0	3.1	7.2	800	17.2	1.69	11.4	89.9	2.97	2.5	800	23.4	13.6	0.58	0.84	26.3	27.7	-
30	4.0	0.9	2.2	Operation not recommended							Operation not recommended							
	6.0	2.0	4.7	800	18.3	1.65	12.7	91.2	3.25	2.4	800	23.4	13.6	0.58	0.84	26.3	27.7	-
	8.0	3.0	7.0	800	19.9	1.73	14.0	93.0	3.37	2.5	800	23.5	13.6	0.58	0.82	26.6	28.7	-
40	4.0	0.9	2.1	Operation not recommended							Operation not recommended							
	6.0	2.0	4.6	800	21.6	1.68	15.9	95.1	3.77	2.5	800	26.2	16.9	0.65	0.93	29.4	28.3	-
	8.0	2.9	6.7	800	22.8	1.72	16.9	96.4	3.88	2.6	800	26.4	16.9	0.64	0.90	29.5	29.4	-
50	4.0	0.9	2.0	800	24.1	1.71	18.3	97.9	4.14	2.6	800	28.4	19.4	0.68	1.04	31.9	27.4	1.0
	6.0	1.9	4.4	800	25.0	1.71	19.1	98.9	4.28	2.7	800	28.6	19.5	0.68	1.01	32.1	28.4	0.9
	8.0	2.8	6.5	800	26.1	1.75	20.2	100.2	4.38	2.8	800	29.1	20.0	0.69	1.00	32.5	29.1	0.9
60	4.0	0.9	2.0	800	27.3	1.75	21.3	101.6	4.56	2.9	800	27.9	19.6	0.70	1.18	31.9	23.6	1.3
	6.0	1.9	4.3	800	28.4	1.75	22.4	102.9	4.75	3.0	800	28.1	19.7	0.70	1.15	32.1	24.4	1.3
	8.0	2.7	6.3	800	29.4	1.79	23.3	104.0	4.81	3.0	800	28.6	20.2	0.71	1.14	32.5	25.0	1.2
70	4.0	0.8	1.9	800	30.5	1.80	24.3	105.3	4.96	3.2	800	27.4	19.8	0.72	1.33	32.0	20.6	1.9
	6.0	1.8	4.2	800	31.1	1.81	24.9	98.8	5.04	2.9	800	28.2	21.9	0.78	1.36	32.8	20.8	2.0
	8.0	2.7	6.1	800	31.8	1.79	25.7	106.8	5.19	3.3	800	27.7	19.9	0.72	1.30	32.1	21.3	1.7
80	4.0	0.8	1.9	800	32.4	1.79	26.3	100.0	5.29	3.0	800	28.4	22.0	0.78	1.32	32.9	21.5	1.9
	6.0	1.7	4.0	800	32.6	1.83	26.4	107.8	5.22	3.4	800	28.1	20.4	0.73	1.29	32.5	21.9	1.6
	8.0	2.6	5.9	800	33.2	1.83	27.0	100.7	5.32	3.1	800	28.9	22.6	0.78	1.31	33.4	22.1	1.8
90	4.0	0.8	1.8	800	33.3	1.83	27.1	108.6	5.34	3.6	800	25.6	19.4	0.76	1.53	30.8	16.8	2.5
	6.0	1.7	3.9	800	33.8	1.82	27.6	101.3	5.44	3.3	800	26.3	21.5	0.82	1.56	31.6	16.9	2.7
	8.0	2.5	5.7	800	34.9	1.82	28.7	110.4	5.63	3.7	800	25.8	19.5	0.76	1.49	30.9	17.4	2.4
100	4.0	0.8	1.8	800	35.4	1.81	29.2	102.7	5.74	3.4	800	26.6	21.6	0.81	1.52	31.7	17.5	2.6
	6.0	1.7	3.9	800	35.4	1.86	29.1	111.0	5.59	3.8	800	26.3	20.0	0.76	1.48	31.3	17.8	2.2
	8.0	2.5	5.7	800	35.8	1.84	29.5	103.1	5.70	3.5	800	27.0	22.2	0.82	1.51	32.1	17.9	2.5
110	4.0	0.8	1.8	800	36.2	1.86	29.9	111.9	5.71	4.0	800	23.8	19.0	0.80	1.73	29.7	13.8	3.4
	6.0	1.7	3.9	800	36.5	1.84	30.2	103.8	5.82	3.7	800	24.5	21.0	0.86	1.76	30.5	13.9	3.6
	8.0	2.5	5.7	800	38.1	1.84	31.8	114.1	6.05	4.2	800	24.0	19.1	0.80	1.68	29.8	14.3	3.2
120	4.0	0.7	1.7	800	38.3	1.82	32.1	105.5	6.18	3.8	800	24.7	21.2	0.86	1.72	30.5	14.4	3.4
	6.0	1.5	3.5	800	38.2	1.88	32.0	114.2	5.96	4.3	800	24.2	19.3	0.80	1.65	30.0	14.7	2.9
	8.0	2.2	5.1	800	38.4	1.85	32.1	105.6	6.08	4.0	800	25.1	21.7	0.86	1.70	30.9	14.8	3.3
100	4.0	0.7	1.7	Operation not recommended							Operation not recommended							
	6.0	1.6	3.7	Operation not recommended							Operation not recommended							
	8.0	2.4	5.5	800	22.5	18.5	0.82	1.93	29.1	11.7	4.1	800	22.9	19.0	0.83	1.91	29.4	12.0
110	4.0	0.7	1.7	Operation not recommended							Operation not recommended							
	6.0	1.6	3.6	Operation not recommended							Operation not recommended							
	8.0	2.3	5.3	800	21.1	18.0	0.85	2.17	28.5	9.7	5.2	800	21.4	18.4	0.86	2.15	28.7	10.0
120	4.0	0.7	1.6	Operation not recommended							Operation not recommended							
	6.0	1.5	3.5	Operation not recommended							Operation not recommended							
	8.0	2.2	5.1	800	18.8	16.2	0.86	2.49	27.3	7.5	6.5	800	19.2	17.6	0.92	2.56	27.9	7.5
											800	19.0	16.2	0.85	2.41	27.2	7.9	6.0
											800	19.4	17.6	0.91	2.49	27.9	7.8	6.7

Multiple Flow Rates (for EWT) are shown in the table above. The lowest flow rate shown is used for geothermal open loop/well water systems with a minimum 50° F. The second flow rate shown is the minimum geothermal closed loop flow rate. The third flow rate shown is optimum for geothermal closed loop and the suggested flow rate for boiler tower applications. 3/7/17

The manufacturer works continually to improve its products. As a result, the design and specifications of each product at the time of order may be changed without notice. Purchaser's approval of this data set signifies that the equipment is acceptable under the provisions of the job specification. Statements and other information contained herein are not express warranties and do not form the basis of any bargain between the parties, but are merely the manufacturer's opinion or commendation of its products. York and Affinity are registered trademarks of Johnson Controls, Inc., and are used with permission.

Contractor: \_\_\_\_\_ P.O.: \_\_\_\_\_

Engineer: \_\_\_\_\_

Project Name: \_\_\_\_\_ Unit Tag: \_\_\_\_\_

**Affinity Single & Dual Capacity  
Indoor Split Series  
2 - 6 Tons 60Hz**



## Model 038 High Speed - Performance Data

### 038 - Dual Capacity High Speed

EWT °F	Flow gpm	WPD		HEATING - EAT 70°F							COOLING - EAT 80/67 °F							
		PSI	FT	Airflow cfm	HC Mbtu/h	Power kW	HE Mbtu/h	LAT °F	COP	HWC Mbtu/h	Airflow cfm	TC Mbtu/h	SC Mbtu/h	S/T Ratio	Power kW	HR Mbtu/h	EER	HWC Mbtu/h
20	5.0	1.3	3.0	Operation not recommended							Operation not recommended							
	7.0	2.6	5.9	Operation not recommended							Operation not recommended							
	9.0	3.7	8.7	1000	24.3	2.22	16.7	92.5	3.21	2.9	Operation not recommended							
30	5.0	1.2	2.9	Operation not recommended							Operation not recommended							
	7.0	2.5	5.8	1000	28.2	2.29	20.4	96.1	3.62	3.1	1000	30.4	18.5	0.61	1.41	35.2	21.5	-
	9.0	3.6	8.4	1200	29.0	2.36	21.0	92.4	3.61	2.8	1200	30.9	20.2	0.65	1.49	36.0	20.7	-
40	5.0	1.2	2.8	Operation not recommended							Operation not recommended							
	7.0	2.4	5.6	1000	31.9	2.39	23.8	99.6	3.91	3.4	1000	33.6	20.5	0.61	1.56	38.9	21.6	-
	9.0	3.5	8.2	1200	32.6	2.41	24.3	100.2	3.95	3.5	1200	33.8	20.5	0.61	1.51	39.0	22.4	-
50	5.0	1.2	2.7	1000	34.4	2.44	26.1	101.9	4.14	3.7	1000	34.9	20.5	0.59	1.78	41.0	19.6	1.9
	7.0	2.3	5.4	1200	35.4	2.47	27.0	97.3	4.20	3.4	1200	36.7	22.8	0.62	1.87	43.1	19.6	2.0
	9.0	3.4	7.9	1000	35.7	2.49	27.1	103.0	4.19	3.8	1000	35.7	20.7	0.58	1.68	41.4	21.2	1.8
60	5.0	1.1	2.6	1200	36.8	2.53	28.2	98.4	4.27	3.5	1200	37.5	23.0	0.61	1.76	43.5	21.3	1.9
	7.0	2.3	5.3	1000	36.5	2.52	27.9	103.8	4.25	3.9	1000	36.0	22.1	0.62	1.64	41.6	22.0	1.7
	9.0	3.3	7.6	1200	37.6	2.55	28.9	99.0	4.32	3.6	1200	37.9	24.6	0.65	1.72	43.8	22.0	1.8
70	5.0	1.1	2.5	1000	37.2	2.53	28.6	104.5	4.32	4.2	1000	35.5	22.7	0.64	1.96	42.2	18.1	2.3
	7.0	2.3	5.3	1200	38.4	2.54	29.7	99.6	4.43	3.8	1200	37.2	25.2	0.68	2.04	44.2	18.2	2.4
	9.0	3.3	7.6	1000	38.9	2.60	30.0	106.0	4.39	4.3	1000	36.3	22.9	0.63	1.86	42.7	19.5	2.2
80	5.0	1.1	2.5	1200	40.2	2.61	31.2	101.0	4.50	4.0	1200	38.1	25.4	0.67	1.94	44.7	19.7	2.3
	7.0	2.1	4.9	1000	39.8	2.62	30.9	106.9	4.45	4.4	1000	36.7	24.2	0.66	1.81	42.9	20.2	2.0
	9.0	3.1	7.1	1200	41.2	2.64	32.2	101.8	4.58	4.1	1200	38.5	26.8	0.70	1.90	45.0	20.3	2.2
90	5.0	1.1	2.5	1000	40.1	2.61	31.2	107.1	4.50	4.7	1000	36.1	24.9	0.69	2.13	43.4	16.9	2.9
	7.0	2.2	5.1	1200	42.7	2.67	33.6	102.9	4.69	4.3	1200	37.7	27.7	0.73	2.21	45.2	17.0	3.0
	9.0	3.2	7.4	1000	42.1	2.70	32.9	109.0	4.58	4.8	1000	37.0	25.2	0.68	2.04	44.0	18.2	2.7
100	5.0	1.1	2.5	1200	43.5	2.70	34.3	103.6	4.73	4.4	1200	38.6	27.9	0.72	2.11	45.8	18.3	2.9
	7.0	2.1	4.9	1000	43.2	2.73	33.9	110.0	4.64	5.0	1000	37.4	26.2	0.70	1.99	44.2	18.8	2.5
	9.0	3.1	7.1	1200	44.7	2.72	35.4	104.5	4.82	4.6	1200	39.1	29.0	0.74	2.07	46.2	18.9	2.8
110	5.0	1.1	2.5	1000	43.3	2.73	34.0	110.1	4.65	5.2	1000	34.8	24.6	0.71	2.34	42.8	14.8	3.6
	7.0	2.1	4.9	1200	44.8	2.71	35.6	104.6	4.85	4.8	1200	36.2	27.3	0.76	2.41	44.4	15.0	3.8
	9.0	3.1	7.1	1000	45.8	2.84	36.1	112.4	4.73	5.4	1000	35.7	24.9	0.70	2.26	43.4	15.8	3.3
120	5.0	1.0	2.4	1200	47.3	2.81	37.7	106.5	4.94	5.0	1200	37.2	27.6	0.74	2.33	45.1	16.0	3.6
	7.0	2.0	4.7	1000	47.1	2.87	37.3	113.6	4.80	5.6	1000	36.1	25.5	0.71	2.21	43.7	16.3	3.1
	9.0	3.0	6.9	1200	48.7	2.83	39.0	107.6	5.04	5.1	1200	37.6	28.3	0.75	2.28	45.4	16.5	3.4
130	5.0	1.0	2.4	1000	46.5	2.84	36.8	113.0	4.79	5.9	1000	33.4	24.3	0.73	2.55	42.1	13.1	4.4
	7.0	2.0	4.7	1200	48.1	2.80	38.6	107.1	5.04	5.4	1200	34.6	27.0	0.78	2.62	43.5	13.2	4.7
	9.0	3.0	6.9	1000	49.4	2.97	39.2	115.7	4.87	6.0	1000	34.4	24.6	0.71	2.48	42.9	13.9	4.1
140	5.0	1.0	2.2	1200	51.1	2.92	41.2	109.5	5.14	5.6	1200	35.7	27.3	0.76	2.54	44.4	14.0	4.5
	7.0	1.9	4.4	1000	50.9	3.01	40.7	117.2	4.95	6.2	1000	35.2	25.2	0.72	2.37	43.3	14.9	3.9
	9.0	2.8	6.4	1200	52.7	2.94	42.7	110.7	5.25	5.8	1200	36.1	27.5	0.76	2.49	44.6	14.5	4.3
150	5.0	1.0	2.3	Operation not recommended							Operation not recommended							
	7.0	2.0	4.6	Operation not recommended							1000	31.6	24.0	0.76	2.77	41.0	11.4	5.1
	9.0	2.9	6.6	Operation not recommended							1200	32.6	26.7	0.82	2.81	42.2	11.6	5.5
160	5.0	1.0	2.2	Operation not recommended							Operation not recommended							
	7.0	1.9	4.4	Operation not recommended							1000	31.9	24.0	0.75	2.72	41.2	11.7	4.8
	9.0	2.8	6.4	Operation not recommended							1200	33.0	26.5	0.80	2.76	42.4	11.9	5.3
170	5.0	1.0	2.2	Operation not recommended							Operation not recommended							
	7.0	1.9	4.4	Operation not recommended							1000	28.7	23.4	0.82	3.05	39.1	9.4	6.2
	9.0	2.8	6.4	Operation not recommended							1200	29.5	26.0	0.88	3.07	40.0	9.6	6.8
180	5.0	0.9	2.1	Operation not recommended							Operation not recommended							
	7.0	1.8	4.2	Operation not recommended							1000	29.0	23.1	0.80	3.00	39.2	9.7	5.8
	9.0	2.7	6.1	Operation not recommended							1200	29.8	25.5	0.86	3.03	40.1	9.8	6.4
190	5.0	0.9	2.1	Operation not recommended							Operation not recommended							
	7.0	1.8	4.2	Operation not recommended							1000	26.9	22.8	0.85	3.38	38.4	8.0	7.5
	9.0	2.7	6.1	Operation not recommended							1200	27.4	24.7	0.90	3.46	39.2	7.9	8.1
200	5.0	0.9	2.1	Operation not recommended							Operation not recommended							
	7.0	1.8	4.2	Operation not recommended							1000	27.1	22.8	0.84	3.27	38.3	8.3	7.0
	9.0	2.7	6.1	Operation not recommended							1200	27.7	24.7	0.89	3.37	39.2	8.2	7.7

Multiple Flow Rates (for EWT) are shown in the table above. The lowest flow rate shown is used for geothermal open loop/well water systems with a minimum 50° F. The second flow rate shown is the minimum geothermal closed loop flow rate. The third flow rate shown is optimum for geothermal closed loop and the suggested flow rate for boiler tower applications.

3/7/17

The manufacturer works continually to improve its products. As a result, the design and specifications of each product at the time of order may be changed without notice. Purchaser's approval of this data set signifies that the equipment is acceptable under the provisions of the job specification. Statements and other information contained herein are not express warranties and do not form the basis of any bargain between the parties, but are merely the manufacturer's opinion or commendation of its products. York and Affinity are registered trademarks of Johnson Controls, Inc., and are used with permission.

Contractor: \_\_\_\_\_ P.O.: \_\_\_\_\_

Engineer: \_\_\_\_\_

Project Name: \_\_\_\_\_ Unit Tag: \_\_\_\_\_



## Model 049 Low Speed - Performance Data

### 049 - Dual Capacity Low Speed

EWT °F	Flow gpm	WPD		HEATING - EAT 70°F							COOLING - EAT 80/67 °F							
		PSI	FT	Airflow cfm	HC Mbtu/h	Power kW	HE Mbtu/h	LAT °F	COP	HWC Mbtu/h	Airflow cfm	TC Mbtu/h	SC Mbtu/h	S/T Ratio	Power kW	HR Mbtu/h	EER	HWC Mbtu/h
20	5.0	0.9	2.1	Operation not recommended							Operation not recommended							
	8.0	2.2	5.1	Operation not recommended							Operation not recommended							
	11.0	3.6	8.4	1200	21.1	2.25	13.4	86.3	2.75	4.2	Operation not recommended							
				1400	21.6	2.28	13.8	84.3	2.78	3.8	Operation not recommended							
30	5.0	0.9	2.1	Operation not recommended							Operation not recommended							
	8.0	2.2	5.0	1200	25.1	2.28	17.3	89.3	3.22	4.3	1200	34.3	22.1	0.64	1.22	38.4	28.2	-
				1400	25.8	2.30	18.0	87.1	3.29	3.9	1400	34.8	24.1	0.69	1.28	39.2	27.2	-
	11.0	3.5	8.2	1200	26.0	2.30	18.2	90.1	3.31	4.4	1200	34.5	22.1	0.64	1.18	38.5	29.2	-
				1400	26.6	2.33	18.7	87.6	3.35	4.0	1400	35.3	24.1	0.68	1.24	39.5	28.5	-
	40	5.0	0.9	2.0	Operation not recommended							Operation not recommended						
8.0		2.1	4.8	1200	30.9	2.34	22.9	93.8	3.86	4.5	1200	37.4	25.5	0.68	1.35	42.0	27.8	-
				1400	32.0	2.34	24.0	91.2	4.00	4.2	1400	38.1	27.8	0.73	1.41	42.9	27.0	-
11.0		3.4	7.9	1200	31.9	2.36	23.9	94.6	3.96	4.7	1200	37.7	25.5	0.68	1.31	42.1	28.9	-
				1400	33.0	2.38	24.9	91.8	4.07	4.2	1400	38.5	27.8	0.72	1.37	43.2	28.2	-
50	5.0	0.8	2.0	1200	34.1	2.33	26.1	96.3	4.29	4.8	1200	39.4	26.6	0.68	1.74	45.3	22.7	1.6
				1400	35.2	2.33	27.2	93.3	4.43	4.4	1400	40.6	31.4	0.77	1.81	46.8	22.4	1.7
	8.0	2.0	4.7	1200	36.7	2.40	28.5	98.4	4.48	4.9	1200	40.2	26.7	0.66	1.50	45.4	26.7	1.5
				1400	38.1	2.39	30.0	95.2	4.68	4.5	1400	41.5	31.5	0.76	1.58	46.8	26.3	1.6
	11.0	3.3	7.7	1200	38.1	2.42	29.9	99.4	4.62	5.1	1200	40.5	26.7	0.66	1.42	45.6	28.6	1.4
				1400	39.4	2.42	31.1	96.1	4.77	4.6	1400	41.7	31.5	0.76	1.49	46.8	28.0	1.5
60	5.0	0.8	1.9	1200	36.3	2.40	28.1	98.0	4.43	5.2	1200	37.0	26.2	0.71	1.91	43.5	19.3	2.3
				1400	37.6	2.38	29.4	94.8	4.62	4.8	1400	38.2	30.9	0.81	2.00	45.0	19.1	2.4
	8.0	2.0	4.5	1200	39.2	2.46	30.8	100.3	4.68	5.4	1200	37.6	26.4	0.70	1.70	43.4	22.1	2.1
				1400	40.8	2.43	32.5	97.0	4.92	5.0	1400	38.8	31.1	0.80	1.78	44.8	21.8	2.3
	11.0	3.2	7.4	1200	40.9	2.48	32.4	101.6	4.83	5.5	1200	38.0	26.5	0.70	1.61	43.5	23.6	1.9
				1400	42.4	2.45	34.0	98.0	5.07	5.1	1400	39.2	31.2	0.79	1.69	44.9	23.3	2.2
70	5.0	0.8	1.8	1200	38.5	2.47	30.1	99.7	4.57	5.8	1200	34.6	25.8	0.75	2.09	41.8	16.6	3.2
				1400	42.0	2.46	33.6	97.8	5.00	5.4	1400	35.7	30.4	0.85	2.19	43.2	16.3	3.4
	8.0	1.9	4.4	1200	41.8	2.51	33.2	102.2	4.88	6.0	1200	35.0	26.1	0.75	1.89	42.0	18.5	3.0
				1400	43.4	2.47	35.0	98.7	5.16	5.5	1400	36.1	30.7	0.85	1.98	42.8	18.2	3.2
	11.0	3.1	7.2	1200	43.7	2.54	35.0	103.7	5.04	6.1	1200	35.6	26.2	0.74	1.81	42.3	19.7	2.8
				1400	45.3	2.48	36.8	100.0	5.35	5.7	1400	36.7	30.8	0.84	1.88	43.1	19.5	3.1
80	5.0	0.8	1.8	1200	41.3	2.50	32.7	101.9	4.83	6.5	1200	32.4	24.7	0.76	2.33	40.4	13.9	4.4
				1400	42.9	2.46	34.5	98.4	5.11	6.0	1400	33.4	29.1	0.87	2.43	41.7	13.8	4.6
	8.0	1.8	4.2	1200	44.8	2.53	36.2	104.6	5.19	6.7	1200	32.6	25.0	0.77	2.16	40.0	15.1	4.1
				1400	46.7	2.47	38.2	100.9	5.54	6.1	1400	33.6	29.4	0.88	2.25	41.2	14.9	4.4
	11.0	3.0	6.9	1200	47.1	2.56	38.4	106.4	5.39	6.9	1200	33.3	25.2	0.76	2.07	40.4	16.1	3.8
				1400	49.0	2.49	40.5	102.4	5.77	6.3	1400	34.4	29.6	0.86	2.16	41.7	15.9	4.2
90	5.0	0.7	1.7	1200	44.1	2.54	35.4	104.0	5.08	7.2	1200	30.2	23.6	0.78	2.56	38.3	11.8	5.9
				1400	45.8	2.49	37.3	100.3	5.40	6.7	1400	31.2	27.7	0.89	2.67	40.3	11.7	6.2
	8.0	1.8	4.1	1200	47.9	2.56	39.2	107.0	5.50	7.4	1200	30.2	23.9	0.79	2.43	38.5	12.4	5.5
				1400	49.9	2.47	41.5	103.0	5.92	6.9	1400	31.0	28.1	0.91	2.52	39.6	12.3	5.9
	11.0	2.9	6.7	1200	50.6	2.58	41.8	109.0	5.74	7.7	1200	31.5	26.3	0.83	2.35	39.5	13.4	5.1
				1400	52.7	2.50	44.2	104.9	6.18	7.1	1400	32.0	28.4	0.89	2.43	40.3	13.2	5.6
100	5.0	0.7	1.6	Operation not recommended							Operation not recommended							
	8.0	1.7	3.9	1200	27.5	2.24	0.81	2.73	36.9	10.1	7.1	Operation not recommended						
				1400	28.4	2.64	0.93	2.84	38.1	10.0	7.7	Operation not recommended						
	11.0	2.8	6.5	1200	28.6	2.27	0.80	2.64	37.6	10.8	6.6	Operation not recommended						
1400				29.4	2.67	0.91	2.75	38.8	10.7	7.3	Operation not recommended							
110	5.0	0.7	1.6	Operation not recommended							Operation not recommended							
	8.0	1.6	3.8	Operation not recommended							1200	24.9	20.9	0.84	3.04	35.3	8.2	9.0
				1400	25.7	24.6	0.96	3.16	36.5	8.1	9.8							
	11.0	2.7	6.2	Operation not recommended							1200	26.1	21.3	0.82	2.94	36.1	8.9	8.4
1400				26.8	25.0	0.93	3.07	37.3	8.7	9.3								
120	5.0	0.7	1.5	Operation not recommended							Operation not recommended							
	8.0	1.6	3.6	Operation not recommended							1200	23.9	21.4	0.90	3.45	35.6	6.9	11.2
				1400	24.3	23.2	0.95	3.54	36.4	6.9	12.1							
	11.0	2.6	6.0	Operation not recommended							1200	24.1	21.4	0.89	3.34	35.5	7.2	10.4
1400				24.6	23.2	0.94	3.44	36.3	7.2	11.5								

Multiple Flow Rates (for EWT) are shown in the table above. The lowest flow rate shown is used for geothermal open loop/well water systems with a minimum 50° F. The second flow rate shown is the minimum geothermal closed loop flow rate. The third flow rate shown is optimum for geothermal closed loop and the suggested flow rate for boiler tower applications. 3/7/17

The manufacturer works continually to improve its products. As a result, the design and specifications of each product at the time of order may be changed without notice. Purchaser's approval of this data set signifies that the equipment is acceptable under the provisions of the job specification. Statements and other information contained herein are not express warranties and do not form the basis of any bargain between the parties, but are merely the manufacturer's opinion or commendation of its products. York and Affinity are registered trademarks of Johnson Controls, Inc., and are used with permission.

Contractor: \_\_\_\_\_ P.O.: \_\_\_\_\_

Engineer: \_\_\_\_\_

Project Name: \_\_\_\_\_ Unit Tag: \_\_\_\_\_

**Affinity Single & Dual Capacity  
Indoor Split Series  
2 - 6 Tons 60Hz**



## Model 049 High Speed - Performance Data

### 049 - Dual Capacity High Speed

EWT °F	Flow gpm	WPD		HEATING - EAT 70°F							COOLING - EAT 80/67 °F							
		PSI	FT	Airflow cfm	HC Mbtu/h	Power kW	HE Mbtu/h	LAT °F	COP	HWC Mbtu/h	Airflow cfm	TC Mbtu/h	SC Mbtu/h	S/T Ratio	Power kW	HR Mbtu/h	EER	HWC Mbtu/h
20	6.0	1.3	3.1	Operation not recommended							Operation not recommended							
	9.0	2.8	6.5	Operation not recommended							Operation not recommended							
	12.0	4.3	9.9	1400	35.6	2.95	25.5	93.5	3.53	5.3	Operation not recommended							
30	6.0	1.3	3.0	Operation not recommended							Operation not recommended							
	9.0	2.7	6.3	1400	37.1	3.15	26.4	94.5	3.45	5.6	1400	42.2	29.5	0.70	1.85	48.5	22.9	-
	12.0	4.2	9.6	1600	38.3	3.17	27.4	92.1	3.53	5.2	1600	42.9	32.2	0.75	1.94	49.6	22.1	-
				1400	38.3	3.14	27.6	95.3	3.57	5.6	1400	42.5	29.5	0.69	1.79	48.6	23.7	-
40	6.0	1.2	2.9	Operation not recommended							Operation not recommended							
	9.0	2.6	6.1	1400	42.0	3.28	30.8	97.8	3.76	6.2	1400	46.5	32.5	0.70	2.11	53.7	22.0	-
	12.0	4.0	9.3	1600	43.5	3.28	32.3	95.2	3.89	5.7	1600	47.4	35.5	0.75	2.22	54.9	21.4	-
				1400	43.4	3.30	32.1	98.7	3.85	6.4	1400	46.9	32.5	0.69	2.05	53.9	22.8	-
50	6.0	1.2	2.8	1400	43.5	3.29	32.3	98.8	3.88	6.7	1400	49.4	32.8	0.66	2.81	58.0	17.6	3.0
	9.0	2.6	5.9	1600	44.9	3.29	33.7	96.0	4.00	6.2	1600	50.9	38.6	0.76	2.93	60.5	17.4	3.2
				1400	46.9	3.40	35.3	101.0	4.05	6.9	1400	50.5	32.9	0.65	2.43	58.6	20.7	2.8
	12.0	3.9	9.1	1600	48.7	3.38	37.2	98.2	4.23	6.4	1600	52.0	38.8	0.75	2.55	60.7	20.4	3.0
1400				48.7	3.42	37.0	102.2	4.17	7.2	1400	50.8	32.9	0.65	2.29	58.8	22.2	2.6	
60	6.0	1.2	2.7	1400	47.7	3.47	35.8	101.5	4.03	7.6	1400	48.0	32.1	0.67	2.99	58.2	16.1	3.7
	9.0	2.5	5.7	1600	49.4	3.45	37.6	98.6	4.20	7.0	1600	49.5	37.9	0.77	3.12	60.1	15.9	3.9
				1400	51.6	3.56	39.5	104.1	4.25	7.8	1400	48.7	32.4	0.66	2.65	57.8	18.4	3.4
	12.0	3.8	8.8	1600	53.6	3.51	41.6	101.0	4.47	7.2	1600	50.2	38.1	0.76	2.77	59.7	18.1	3.7
70	6.0	1.1	2.6	1400	53.8	3.59	41.6	105.6	4.39	8.0	1400	49.3	32.5	0.66	2.52	57.9	19.6	3.2
	9.0	2.4	5.5	1600	55.7	3.55	43.6	102.2	4.61	7.4	1600	50.8	38.2	0.75	2.63	59.8	19.3	3.5
				1400	51.9	3.65	39.4	104.3	4.17	8.5	1400	46.5	31.5	0.68	3.17	57.2	14.7	4.6
	12.0	3.7	8.5	1600	57.3	3.58	45.1	103.2	4.69	7.9	1600	48.0	37.1	0.77	3.32	58.3	14.5	4.9
80	6.0	1.1	2.5	1400	56.3	3.71	43.6	107.2	4.45	8.8	1400	47.0	31.9	0.68	2.87	57.8	16.4	4.3
	9.0	2.3	5.4	1600	58.5	3.65	46.1	103.9	4.70	8.1	1600	48.5	37.4	0.77	3.00	58.7	16.2	4.6
				1400	58.9	3.76	46.1	108.9	4.60	9.0	1400	47.8	32.0	0.67	2.74	57.9	17.4	4.0
	12.0	3.5	8.2	1600	61.1	3.67	48.6	105.4	4.88	8.3	1600	49.3	37.6	0.76	2.85	59.0	17.3	4.4
90	6.0	1.1	2.4	1400	55.6	3.83	42.5	106.7	4.26	9.6	1400	43.8	30.5	0.70	3.36	54.3	13.0	5.8
	9.0	2.2	5.2	1600	57.7	3.76	44.9	103.4	4.50	8.8	1600	45.2	35.9	0.79	3.51	56.2	12.9	6.2
				1400	60.3	3.87	47.1	109.9	4.57	9.8	1400	44.1	30.9	0.70	3.12	54.7	14.1	5.4
	12.0	3.4	7.9	1600	62.8	3.77	49.9	106.3	4.88	9.1	1600	45.4	36.3	0.80	3.25	56.5	14.0	5.9
100	6.0	1.0	2.3	1400	63.4	3.91	50.1	111.9	4.75	10.1	1400	45.1	31.1	0.69	2.99	55.2	15.1	5.0
	9.0	2.2	5.0	1600	66.0	3.81	53.0	108.2	5.08	9.4	1600	46.5	36.6	0.79	3.11	57.1	14.9	5.6
				1400	59.2	4.01	45.6	109.2	4.33	10.7	1400	41.1	29.5	0.72	3.55	53.3	11.6	7.3
	12.0	3.3	7.6	1600	61.5	3.92	48.2	105.6	4.60	9.9	1600	42.5	34.7	0.82	3.70	55.1	11.5	7.7
110	6.0	1.0	2.3	1400	64.4	4.03	50.7	112.6	4.69	11.1	1400	41.1	29.9	0.73	3.37	53.6	12.2	6.8
	9.0	2.1	4.8	1600	67.1	3.90	53.8	108.8	5.04	10.2	1600	42.3	35.2	0.83	3.49	54.2	12.1	7.4
				1400	68.0	4.07	54.1	114.9	4.89	11.4	1400	42.9	33.3	0.78	3.27	54.1	13.1	6.3
	12.0	3.0	7.0	1600	70.8	3.94	57.4	111.0	5.27	10.6	1600	43.6	35.5	0.81	3.37	55.1	12.9	7.0
120	6.0	0.9	2.2	Operation not recommended							Operation not recommended							
	9.0	2.0	4.6	Operation not recommended							Operation not recommended							
				1400	34.0	29.6	0.86	4.42	49.4	7.8	11.6							
	12.0	3.0	7.0	1400	34.6	32.1	0.93	4.69	50.6	7.4	13.5							

Multiple Flow Rates (for EWT) are shown in the table above. The lowest flow rate shown is used for geothermal open loop/well water systems with a minimum 50° F. The second flow rate shown is the minimum geothermal closed loop flow rate. The third flow rate shown is optimum for geothermal closed loop and the suggested flow rate for boiler tower applications. 3/7/17

The manufacturer works continually to improve its products. As a result, the design and specifications of each product at the time of order may be changed without notice. Purchaser's approval of this data set signifies that the equipment is acceptable under the provisions of the job specification. Statements and other information contained herein are not express warranties and do not form the basis of any bargain between the parties, but are merely the manufacturer's opinion or commendation of its products. York and Affinity are registered trademarks of Johnson Controls, Inc., and are used with permission.

Contractor: \_\_\_\_\_ P.O.: \_\_\_\_\_

Engineer: \_\_\_\_\_

Project Name: \_\_\_\_\_ Unit Tag: \_\_\_\_\_

**Affinity Single & Dual Capacity  
Indoor Split Series  
2 - 6 Tons 60Hz**



# Model 064 Low Speed - Performance Data

## 064 - Dual Capacity Low Speed

EWT °F	Flow gpm	WPD		HEATING - EAT 70°F							COOLING - EAT 80/67 °F								
		PSI	FT	Airflow cfm	HC Mbtu/h	Power kW	HE Mbtu/h	LAT °F	COP	HWC Mbtu/h	Airflow cfm	TC Mbtu/h	SC Mbtu/h	S/T Ratio	Power kW	HR Mbtu/h	EER	HWC Mbtu/h	
20	6.0	1.1	2.5	Operation not recommended							Operation not recommended								
	10.0	3.4	7.8	Operation not recommended							Operation not recommended								
	14.0	5.8	13.4	1200	26.2	2.79	16.7	90.2	2.76	4.9	Operation not recommended								
				1500	26.9	2.80	17.3	86.6	2.82	4.5	Operation not recommended								
30	6.0	1.1	2.5	Operation not recommended							Operation not recommended								
	10.0	3.3	7.6	1200	30.1	2.85	20.4	93.3	3.10	5.0	1200	43.4	26.3	0.61	1.50	48.5	28.9	-	
	14.0	5.6	13.0	1500	31.2	2.89	21.4	89.3	3.17	4.6	1500	44.1	28.7	0.65	1.58	49.5	27.9	-	
				1200	31.5	2.88	21.7	94.3	3.21	5.1	1200	43.6	26.3	0.60	1.46	48.6	29.9	-	
1500	32.3	2.89	22.4	89.9	3.28	4.7	1500	44.7	28.7	0.64	1.53	49.9	29.2	-					
40	6.0	1.0	2.4	Operation not recommended							Operation not recommended								
	10.0	3.2	7.4	1200	35.5	2.93	25.5	97.4	3.55	5.3	1200	47.0	29.7	0.63	1.67	52.7	28.2	-	
	14.0	5.4	12.6	1500	36.4	2.94	26.4	92.5	3.64	4.9	1500	47.9	32.5	0.68	1.75	53.9	27.4	-	
				1200	36.6	2.94	26.6	98.3	3.66	5.5	1200	47.4	29.7	0.63	1.62	52.9	29.3	-	
1500	37.6	2.95	27.6	93.2	3.74	5.0	1500	48.5	32.5	0.67	1.69	54.2	28.7	-					
50	6.0	1.0	2.3	1200	40.1	2.95	30.1	101.0	3.99	5.6	1200	50.5	31.6	0.63	1.87	56.4	27.0	2.0	
	10.0	3.1	7.2	1500	41.2	2.95	31.1	95.4	4.10	5.2	1500	51.9	35.9	0.69	1.97	58.2	26.4	2.1	
				1200	40.7	3.00	30.5	101.4	3.98	5.7	1200	50.6	31.9	0.63	1.80	56.7	28.1	1.9	
	14.0	5.3	12.2	1500	41.7	2.98	31.5	95.7	4.09	5.3	1500	52.1	36.2	0.70	1.88	58.5	27.6	2.0	
1200				42.0	3.02	31.7	102.4	4.08	5.9	1200	50.7	31.9	0.63	1.77	56.9	28.7	1.7		
1500	42.9	3.00	32.7	96.5	4.19	5.4	1500	52.2	36.2	0.69	1.85	28.7	28.2	1.9					
60	6.0	1.0	2.2	1200	44.9	3.02	34.6	104.7	4.35	6.1	1200	48.3	30.9	0.64	2.12	55.4	22.8	2.8	
	10.0	3.0	6.9	1500	45.9	3.00	35.6	98.3	4.48	5.7	1500	49.8	34.9	0.70	2.22	57.0	22.4	3.0	
				1200	46.3	3.08	35.8	105.7	4.41	6.3	1200	48.5	31.2	0.64	2.05	55.6	23.6	2.6	
	14.0	5.1	11.8	1500	47.0	3.03	36.7	99.0	4.55	5.8	1500	50.0	35.2	0.70	2.15	57.3	23.3	2.9	
1200				47.4	3.10	36.8	106.6	4.48	6.5	1200	48.7	31.3	0.64	2.01	55.7	24.2	2.5		
1500	48.2	3.06	37.7	99.7	4.61	6.0	1500	50.2	35.3	0.70	2.11	57.4	23.8	2.7					
70	6.0	0.9	2.2	1200	49.7	3.10	39.1	108.4	4.70	6.8	1200	46.2	30.2	0.65	2.38	54.3	19.4	4.0	
	10.0	2.9	6.7	1500	49.6	3.07	39.1	100.6	4.74	6.3	1500	47.6	33.9	0.71	2.48	56.1	19.2	4.2	
				1200	51.8	3.15	41.1	110.0	4.82	7.0	1200	46.5	30.5	0.66	2.31	54.4	20.1	3.7	
	14.0	4.9	11.4	1500	52.4	3.09	41.9	102.4	4.98	6.5	1500	47.9	34.3	0.72	2.41	56.1	19.9	4.0	
1200				52.8	3.19	42.0	110.8	4.85	7.2	1200	46.8	30.6	0.65	2.26	54.5	20.7	3.5		
1500	53.4	3.12	42.8	103.0	5.02	6.6	1500	48.2	34.4	0.71	2.36	56.3	20.4	3.9					
80	6.0	0.9	2.1	1200	53.6	3.17	42.8	111.4	4.96	7.6	1200	43.1	28.6	0.66	2.71	52.3	15.9	5.5	
	10.0	2.8	6.5	1500	54.1	3.10	43.5	103.4	5.12	7.0	1500	44.4	31.9	0.72	2.81	53.9	15.8	5.9	
				1200	56.6	3.22	45.6	113.7	5.16	7.8	1200	43.4	28.9	0.66	2.64	52.5	16.4	5.2	
	14.0	4.8	11.0	1500	56.9	3.12	46.2	105.1	5.34	7.2	1500	44.7	32.3	0.72	2.75	54.1	16.3	5.6	
1200				57.3	3.26	46.2	114.2	5.15	8.0	1200	43.7	29.1	0.66	2.60	52.6	16.8	4.8		
1500	57.5	3.17	46.7	105.5	5.32	7.4	1500	45.1	32.5	0.72	2.70	54.3	16.7	5.3					
90	6.0	0.9	2.0	1200	57.5	3.23	46.5	114.3	5.22	8.5	1200	39.9	27.0	0.68	3.05	50.3	13.1	7.4	
	10.0	2.7	6.2	1500	57.6	3.14	46.9	105.6	5.37	7.8	1500	41.1	30.0	0.73	3.13	51.8	13.1	7.8	
				1200	61.3	3.28	50.1	117.3	5.48	8.7	1200	40.4	27.2	0.67	2.98	50.5	13.6	6.9	
	14.0	4.6	10.6	1500	61.3	3.16	50.6	107.9	5.69	8.1	1500	41.6	30.3	0.73	3.08	52.1	13.5	7.5	
1200				61.7	3.33	50.4	117.6	5.44	9.0	1200	40.2	28.0	0.70	2.94	50.7	13.7	6.4		
1500	61.6	3.21	50.6	108.0	5.62	8.3	1500	42.0	30.6	0.73	3.03	52.3	13.9	7.1					
100	6.0	0.8	2.0	Operation not recommended							Operation not recommended								
	10.0	2.6	6.0	1200	37.6	26.3	0.70	3.40	49.2	11.1	9.0	1200	37.6	26.3	0.70	3.40	49.2	11.1	9.0
				1500	38.7	29.1	0.75	3.49	50.7	11.1	9.7	1500	38.7	29.1	0.75	3.49	50.7	11.1	9.7
	14.0	4.4	10.3	1200	38.0	26.6	0.70	3.35	49.4	11.3	8.3	1200	38.0	26.6	0.70	3.35	49.4	11.3	8.3
1500				39.2	29.5	0.75	3.44	50.9	11.4	9.2	1500	39.2	29.5	0.75	3.44	50.9	11.4	9.2	
110	6.0	0.8	1.9	Operation not recommended							Operation not recommended								
	10.0	2.5	5.8	Operation not recommended							1200	34.8	25.4	0.73	3.82	47.9	9.1	11.3	
				1500	35.9	27.9	0.78	3.90	49.2	9.2	12.3	1500	35.9	27.9	0.78	3.90	49.2	9.2	12.3
	14.0	4.3	9.9	Operation not recommended							1200	35.3	25.8	0.73	3.76	48.2	9.4	10.5	
1500				36.4	28.3	0.78	3.84	49.5	9.5	11.7	1500	36.4	28.3	0.78	3.84	49.5	9.5	11.7	
120	6.0	0.8	1.8	Operation not recommended							Operation not recommended								
	10.0	2.4	5.6	Operation not recommended							1200	31.8	24.0	0.76	4.35	46.7	7.3	14.0	
				1500	32.4	26.1	0.81	4.46	47.6	7.3	15.2	1500	32.4	26.1	0.81	4.46	47.6	7.3	15.2
	14.0	4.1	9.5	Operation not recommended							1200	32.1	24.0	0.75	4.21	46.5	7.6	13.0	
1500				32.8	26.1	0.80	4.34	47.6	7.6	14.5	1500	32.8	26.1	0.80	4.34	47.6	7.6	14.5	

Multiple Flow Rates (for EWT) are shown in the table above. The lowest flow rate shown is used for geothermal open loop/well water systems with a minimum 50° F. The second flow rate shown is the minimum geothermal closed loop flow rate. The third flow rate shown is optimum for geothermal closed loop and the suggested flow rate for boiler tower applications. 3/7/17

The manufacturer works continually to improve its products. As a result, the design and specifications of each product at the time of order may be changed without notice. Purchaser's approval of this data set signifies that the equipment is acceptable under the provisions of the job specification. Statements and other information contained herein are not express warranties and do not form the basis of any bargain between the parties, but are merely the manufacturer's opinion or commendation of its products. York and Affinity are registered trademarks of Johnson Controls, Inc., and are used with permission.

Contractor: \_\_\_\_\_ P.O.: \_\_\_\_\_

Engineer: \_\_\_\_\_

Project Name: \_\_\_\_\_ Unit Tag: \_\_\_\_\_

**Affinity Single & Dual Capacity  
Indoor Split Series  
2 - 6 Tons 60Hz**



# Model 064 High Speed - Performance Data

## 064 - Dual Capacity High Speed

EWT °F	Flow gpm	WPD		HEATING - EAT 70°F							COOLING - EAT 80/67 °F							
		PSI	FT	Airflow cfm	HC Mbtu/h	Power kW	HE Mbtu/h	LAT °F	COP	HWC Mbtu/h	Airflow cfm	TC Mbtu/h	SC Mbtu/h	S/T Ratio	Power kW	HR Mbtu/h	EER	HWC Mbtu/h
20	8.0	1.9	4.3	Operation not recommended							Operation not recommended							
	12.0	4.2	9.7	Operation not recommended							Operation not recommended							
	16.0	6.7	15.4	1500	37.1	3.77	24.3	92.9	2.89	6.2	Operation not recommended							
				1800	37.7	3.80	24.7	89.4	2.91	5.6	Operation not recommended							
30	8.0	1.8	4.2	Operation not recommended							Operation not recommended							
	12.0	4.1	9.5	1500	45.3	3.68	32.7	97.9	3.61	6.5	1500	56.2	34.2	0.61	2.49	64.7	22.5	-
				1800	46.5	3.91	33.1	93.9	3.48	6.0	1800	57.1	37.4	0.65	2.63	66.1	21.7	-
	16.0	6.5	14.9	1500	46.3	3.92	32.9	98.6	3.46	6.7	1500	56.5	34.2	0.61	2.42	64.8	23.4	-
1800				47.0	3.95	33.5	94.2	3.49	6.1	1800	57.9	37.4	0.65	2.54	66.6	22.8	-	
40	8.0	1.8	4.0	Operation not recommended							Operation not recommended							
	12.0	4.0	9.2	1500	51.5	3.91	38.2	101.8	3.86	7.2	1500	60.4	37.7	0.62	2.75	69.8	22.0	-
				1800	52.7	4.07	38.8	97.1	3.79	6.6	1800	61.5	41.2	0.67	2.88	71.3	21.3	-
	16.0	6.3	14.5	1500	52.3	3.98	38.7	102.3	3.86	7.4	1500	60.8	37.7	0.62	2.67	69.9	22.8	-
1800				53.5	4.12	39.5	97.5	3.81	6.7	1800	62.2	41.2	0.66	2.79	71.7	22.3	-	
50	8.0	1.7	3.9	1500	54.6	4.05	40.8	103.7	3.95	7.8	1500	63.9	40.5	0.63	2.97	74.0	21.5	4.0
				1800	55.8	4.18	41.5	98.7	3.91	7.2	1800	65.2	44.1	0.68	3.16	76.0	20.6	4.2
	12.0	3.8	8.9	1500	57.8	4.13	43.7	105.7	4.10	8.0	1500	64.5	40.9	0.63	2.91	74.5	22.2	3.7
				1800	58.9	4.23	44.5	100.3	4.08	7.4	1800	65.8	44.5	0.68	3.09	76.4	21.3	4.0
16.0	6.1	14.0	1500	58.7	4.18	44.5	106.3	4.12	8.2	1500	65.2	41.4	0.63	2.86	75.0	22.8	3.4	
			1800	60.0	4.28	45.4	100.9	4.11	7.5	1800	66.5	44.9	0.68	3.04	76.9	21.9	3.8	
60	8.0	1.6	3.8	1500	60.7	4.29	46.0	107.5	4.15	8.7	1500	61.5	39.4	0.64	3.22	72.4	19.1	4.8
				1800	62.0	4.36	47.1	101.9	4.17	8.0	1800	63.0	42.8	0.68	3.42	74.7	18.4	5.1
	12.0	3.7	8.6	1500	63.5	4.36	48.6	109.2	4.27	9.0	1500	62.1	39.8	0.64	3.15	72.8	19.7	4.5
				1800	64.8	4.42	49.8	103.3	4.30	8.3	1800	63.7	43.2	0.68	3.35	75.1	19.0	4.9
16.0	5.9	13.6	1500	64.8	4.41	49.8	110.0	4.31	9.2	1500	62.7	40.2	0.64	3.10	73.3	20.2	4.2	
			1800	66.3	4.46	51.1	104.1	4.36	8.5	1800	64.3	43.7	0.68	3.30	75.5	19.5	4.6	
70	8.0	1.6	3.7	1500	66.7	4.52	51.3	111.2	4.33	9.8	1500	59.0	38.3	0.65	3.46	70.8	17.0	6.1
				1800	68.4	4.54	52.9	105.2	4.42	9.0	1800	60.8	41.6	0.68	3.69	73.4	16.5	6.4
	12.0	3.6	8.3	1500	69.2	4.59	53.5	112.7	4.42	10.1	1500	59.6	38.6	0.65	3.39	71.2	17.6	5.7
				1800	70.7	4.60	55.1	106.4	4.51	9.3	1800	61.5	41.9	0.68	3.61	73.8	17.0	6.1
16.0	5.7	13.1	1500	70.9	4.64	55.1	113.8	4.48	10.4	1500	60.2	39.0	0.65	3.34	71.6	18.0	5.3	
			1800	72.6	4.64	56.8	107.3	4.59	9.6	1800	62.1	42.4	0.68	3.55	74.2	17.5	5.8	
80	8.0	1.5	3.5	1500	71.5	4.72	55.4	114.2	4.44	11.0	1500	57.2	36.9	0.65	3.80	70.1	15.0	7.7
				1800	73.2	4.70	57.2	107.7	4.57	10.2	1800	59.3	40.1	0.68	4.05	73.1	14.6	8.1
	12.0	3.5	8.0	1500	73.2	4.78	56.9	115.2	4.49	11.3	1500	57.8	37.2	0.64	3.73	70.5	15.5	7.1
				1800	75.0	4.73	58.8	108.6	4.64	10.5	1800	59.9	40.4	0.68	3.96	73.4	15.1	7.7
16.0	5.5	12.7	1500	75.5	4.84	59.0	116.6	4.57	11.7	1500	58.3	37.6	0.64	3.66	70.8	15.9	6.6	
			1800	77.4	4.78	61.0	109.8	4.74	10.8	1800	60.5	40.9	0.68	3.90	73.8	15.5	7.4	
90	8.0	1.5	3.4	1500	76.3	4.92	59.5	117.1	4.55	12.4	1500	55.3	35.5	0.64	4.14	69.4	13.4	9.6
				1800	78.2	4.85	61.6	110.2	4.73	11.4	1800	57.7	38.6	0.67	4.41	72.8	13.1	10.2
	12.0	3.4	7.7	1500	77.3	4.97	60.4	117.7	4.56	12.7	1500	55.9	35.8	0.64	4.06	69.8	13.8	9.0
				1800	79.3	4.87	62.7	110.8	4.77	11.8	1800	58.3	38.9	0.67	4.32	73.0	13.5	9.7
16.0	5.3	12.2	1500	80.0	5.03	62.8	119.4	4.66	13.1	1500	57.8	37.1	0.64	4.11	71.8	14.1	8.3	
			1800	82.1	4.92	65.3	112.2	4.89	12.2	1800	58.9	39.3	0.67	4.25	73.4	13.9	9.2	
100	8.0	1.4	3.3	Operation not recommended							Operation not recommended							
	12.0	3.2	7.5	1500	52.3	34.6	0.66	4.53	67.7	11.5	11.1	Operation not recommended						
				1800	54.8	37.6	0.69	4.83	71.2	11.3	12.1	Operation not recommended						
	16.0	5.1	11.8	1500	52.8	35.0	0.66	4.45	68.0	11.9	10.3	Operation not recommended						
1800				55.3	38.0	0.69	4.75	71.5	11.6	11.5	Operation not recommended							
110	8.0	1.4	3.2	Operation not recommended							Operation not recommended							
	12.0	3.1	7.2	Operation not recommended							1500	48.6	33.4	0.69	5.01	65.7	9.7	13.6
				1800	51.2	36.3	0.71	5.34	69.5	9.6	14.8							
	16.0	4.9	11.4	Operation not recommended							1500	49.1	33.8	0.69	4.92	65.9	10.0	12.7
1800				51.7	36.7	0.71	5.25	69.6	9.8	14.1								
120	8.0	1.3	3.0	Operation not recommended							Operation not recommended							
	12.0	3.0	6.9	Operation not recommended							1500	46.8	31.0	0.66	5.55	65.7	8.4	16.5
				1800	47.6	33.7	0.71	5.69	67.1	8.4	17.9							
	16.0	4.7	10.9	Operation not recommended							1500	47.2	31.0	0.66	5.37	65.5	8.8	15.3
1800				48.2	33.7	0.70	5.54	67.1	8.7	17.0								

Multiple Flow Rates (for EWT) are shown in the table above. The lowest flow rate shown is used for geothermal open loop/well water systems with a minimum 50° F. The second flow rate shown is the minimum geothermal closed loop flow rate. The third flow rate shown is optimum for geothermal closed loop and the suggested flow rate for boiler tower applications. 3/7/17

The manufacturer works continually to improve its products. As a result, the design and specifications of each product at the time of order may be changed without notice. Purchaser's approval of this data set signifies that the equipment is acceptable under the provisions of the job specification. Statements and other information contained herein are not express warranties and do not form the basis of any bargain between the parties, but are merely the manufacturer's opinion or commendation of its products. York and Affinity are registered trademarks of Johnson Controls, Inc., and are used with permission.

Contractor: \_\_\_\_\_ P.O.: \_\_\_\_\_

Engineer: \_\_\_\_\_

Project Name: \_\_\_\_\_ Unit Tag: \_\_\_\_\_

**Affinity Single & Dual Capacity  
Indoor Split Series  
2 - 6 Tons 60Hz**



## Model 072 Low Speed - Performance Data

### 072 - Dual Capacity Low Speed

EWT °F	Flow gpm	WPD		HEATING - EAT 70°F							COOLING - EAT 80/67 °F							
		PSI	FT	Airflow cfm	HC Mbtu/h	Power kW	HE Mbtu/h	LAT °F	COP	HWC Mbtu/h	Airflow cfm	TC Mbtu/h	SC Mbtu/h	S/T Ratio	Power kW	HR Mbtu/h	EER	HWC Mbtu/h
20	10.0	2.5	5.7	Operation not recommended							Operation not recommended							
	13.0	4.1	9.5	Operation not recommended							Operation not recommended							
	16.0	5.7	13.2	1400	35.8	3.77	22.9	93.7	2.78	6.0	Operation not recommended							
30	10.0	2.4	5.6	Operation not recommended							Operation not recommended							
				1400	38.8	3.84	25.7	95.6	2.96	6.1	1400	50.6	30.1	0.60	1.76	56.6	28.8	-
	13.0	4.0	9.2	1600	40.7	3.89	27.4	93.6	3.07	5.6	1600	51.4	32.9	0.64	1.85	57.7	27.8	-
				1400	41.9	3.95	28.4	97.7	3.11	6.3	1400	50.9	30.1	0.59	1.70	56.7	29.8	-
	16.0	5.6	12.8	1600	42.4	3.89	29.1	94.5	3.19	5.7	1600	52.1	32.9	0.63	1.79	58.2	29.1	-
40	10.0	2.3	5.4	Operation not recommended							Operation not recommended							
				1400	44.9	4.00	31.2	99.7	3.29	6.5	1400	54.4	33.4	0.61	1.98	61.2	27.5	-
	13.0	3.9	8.9	1600	46.8	4.01	33.1	97.1	3.42	5.9	1600	55.4	36.5	0.66	2.08	62.5	26.7	-
				1400	46.4	4.01	32.7	100.7	3.39	6.7	1400	54.8	33.4	0.61	1.92	61.4	28.5	-
	16.0	5.4	12.5	1600	48.5	4.03	34.8	98.1	3.53	6.1	1600	56.1	36.5	0.65	2.01	62.9	27.9	-
50	10.0	2.3	5.2	1400	50.1	4.12	36.1	103.2	3.57	6.8	1400	57.9	35.0	0.60	2.25	64.6	25.8	2.3
				1600	52.4	4.07	38.5	100.3	3.77	6.3	1600	59.7	39.7	0.66	2.36	66.8	25.2	2.4
	13.0	3.7	8.6	1400	50.9	4.16	36.7	103.7	3.59	7.0	1400	58.1	35.3	0.61	2.17	65.5	26.7	2.1
				1600	52.9	4.14	38.8	100.6	3.75	6.4	1600	59.9	40.1	0.67	2.29	67.3	26.2	2.3
	16.0	5.2	12.1	1400	52.4	4.18	38.1	104.6	3.67	7.2	1400	58.2	35.3	0.61	2.11	66.0	27.5	2.0
60	10.0	2.2	5.1	1400	55.5	4.24	41.0	106.7	3.83	7.5	1400	55.2	34.3	0.62	2.60	63.7	21.2	3.2
				1600	57.8	4.16	43.7	103.5	4.08	6.9	1600	56.9	38.7	0.68	2.72	65.8	20.9	3.4
	13.0	3.6	8.4	1400	57.1	4.29	42.4	107.7	3.90	7.7	1400	55.4	34.6	0.62	2.52	64.0	22.0	3.0
				1600	59.3	4.21	44.9	104.3	4.13	7.1	1600	57.1	39.1	0.69	2.63	66.1	21.7	3.2
	16.0	5.1	11.7	1400	58.4	4.33	43.6	108.6	3.95	7.9	1400	55.7	34.7	0.62	2.47	64.4	22.5	2.8
70	10.0	2.1	4.9	1400	60.9	4.37	46.0	110.3	4.08	8.3	1400	52.5	33.5	0.64	2.96	62.3	17.8	4.5
				1600	64.5	4.33	49.7	107.3	4.37	7.7	1600	54.0	37.7	0.70	3.07	64.1	17.6	4.8
	13.0	3.5	8.1	1400	63.2	4.41	48.1	111.8	4.19	8.5	1400	52.8	33.9	0.64	2.86	62.6	18.5	4.2
				1600	65.6	4.29	51.0	108.0	4.49	7.9	1600	54.3	38.2	0.70	2.98	64.5	18.3	4.5
	16.0	4.9	11.3	1400	64.3	4.48	49.0	112.5	4.21	8.8	1400	53.1	34.1	0.64	2.82	62.8	18.8	3.9
80	10.0	2.0	4.7	1400	65.4	4.49	50.1	113.3	4.27	9.2	1400	48.2	32.1	0.67	3.35	59.7	14.4	6.2
				1600	67.8	4.33	53.0	109.2	4.59	8.5	1600	51.2	35.9	0.70	3.45	63.0	14.9	6.6
	13.0	3.4	7.8	1400	68.9	4.55	53.3	115.5	4.44	9.5	1400	50.1	32.5	0.65	3.27	61.3	15.3	5.8
				1600	71.3	4.36	56.4	111.3	4.79	8.8	1600	51.6	36.3	0.70	3.36	63.1	15.4	6.3
	16.0	4.7	10.9	1400	69.7	4.61	53.9	116.1	4.43	9.8	1400	50.5	32.7	0.65	3.22	61.5	15.7	5.4
90	10.0	2.0	4.6	1400	70.0	4.62	54.2	116.3	4.44	10.3	1400	43.9	30.7	0.70	3.75	56.7	11.7	8.3
				1600	72.3	4.42	57.2	111.8	4.79	9.5	1600	45.3	34.1	0.75	3.83	58.3	11.8	8.8
	13.0	3.3	7.5	1400	74.5	4.68	58.5	119.3	4.67	10.6	1400	44.4	31.0	0.70	3.67	57.7	12.1	7.7
				1600	77.0	4.44	61.8	114.6	5.08	9.8	1600	45.7	34.5	0.75	3.75	58.5	12.2	8.4
	16.0	4.6	10.5	1400	75.0	4.74	58.8	119.6	4.63	11.0	1400	46.8	33.2	0.71	3.73	59.5	12.5	7.2
100	10.0	1.9	4.4	Operation not recommended							Operation not recommended							
				1400	41.9	29.6	0.71	4.30	56.5	9.7	10.0	Operation not recommended						
	13.0	3.1	7.3	1600	43.2	32.7	0.76	4.35	58.1	9.9	10.9	Operation not recommended						
				1400	42.4	29.9	0.70	4.23	56.9	10.0	9.3	Operation not recommended						
	16.0	4.4	10.1	1600	43.7	33.1	0.76	4.29	58.3	10.2	10.0	Operation not recommended						
110	10.0	1.8	4.2	Operation not recommended							Operation not recommended							
				1400	39.4	28.1	0.71	4.92	56.2	8.0	12.7	Operation not recommended						
	13.0	3.0	7.0	1600	40.7	31.0	0.76	4.95	57.6	8.2	13.8	Operation not recommended						
				1400	40.0	28.5	0.71	4.86	56.6	8.2	11.8	Operation not recommended						
16.0	4.2	9.8	1600	41.2	31.4	0.76	4.88	57.9	8.4	13.1	Operation not recommended							
120	10.0	1.8	4.1	Operation not recommended							Operation not recommended							
				1400	37.5	28.1	0.75	5.49	56.2	6.8	15.8	Operation not recommended						
	13.0	2.9	6.7	1600	38.1	30.5	0.80	5.63	57.4	6.8	17.1	Operation not recommended						
				1400	37.8	28.1	0.74	5.31	55.9	7.1	14.6	Operation not recommended						
16.0	4.1	9.4	1600	38.6	30.5	0.79	5.48	57.3	7.0	16.3	Operation not recommended							

3/7/17

Multiple Flow Rates (for EWT) are shown in the table above. The lowest flow rate shown is used for geothermal open loop/well water systems with a minimum 50° F. The second flow rate shown is the minimum geothermal closed loop flow rate. The third flow rate shown is optimum for geothermal closed loop and the suggested flow rate for boiler tower applications.

The manufacturer works continually to improve its products. As a result, the design and specifications of each product at the time of order may be changed without notice. Purchaser's approval of this data set signifies that the equipment is acceptable under the provisions of the job specification. Statements and other information contained herein are not express warranties and do not form the basis of any bargain between the parties, but are merely the manufacturer's opinion or commendation of its products. York and Affinity are registered trademarks of Johnson Controls, Inc., and are used with permission.

Contractor: \_\_\_\_\_ P.O.: \_\_\_\_\_

Engineer: \_\_\_\_\_

Project Name: \_\_\_\_\_ Unit Tag: \_\_\_\_\_



# Model 072 High Speed - Performance Data

## 072 - Dual Capacity High Speed

EWT °F	Flow gpm	WPD		HEATING - EAT 70°F							COOLING - EAT 80/67 °F							
		PSI	FT	Airflow cfm	HC Mbtu/h	Power kW	HE Mbtu/h	LAT °F	COP	HWC Mbtu/h	Airflow cfm	TC Mbtu/h	SC Mbtu/h	S/T Ratio	Power kW	HR Mbtu/h	EER	HWC Mbtu/h
20	12.0	3.4	7.9	Operation not recommended							Operation not recommended							
	15.0	5.1	11.9	Operation not recommended							Operation not recommended							
	18.0	7.0	16.1	1800	36.7	4.41	21.6	88.9	2.44	7.9	Operation not recommended							
30	12.0	3.3	7.7	Operation not recommended							Operation not recommended							
	15.0	5.0	11.6	1800	54.7	4.80	38.3	98.1	3.34	8.3	1800	62.7	37.3	0.60	2.87	72.5	21.9	-
	18.0	6.8	15.6	2000	56.6	5.11	39.2	96.2	3.25	7.6	2000	63.8	40.8	0.64	3.02	74.1	21.1	-
40	12.0	3.2	7.5	Operation not recommended							Operation not recommended							
	15.0	4.8	11.2	1800	61.8	5.07	44.5	101.8	3.57	9.2	1800	67.5	41.4	0.61	3.17	78.3	21.3	-
	18.0	6.6	15.2	2000	62.6	5.12	45.2	102.2	3.58	9.5	2000	68.0	41.4	0.61	3.07	78.5	22.1	-
50	12.0	3.1	7.2	1800	65.2	5.22	47.4	103.5	3.66	9.9	1800	71.5	44.7	0.63	3.43	83.2	20.9	4.3
	15.0	4.7	10.9	2000	67.4	5.41	48.9	101.2	3.65	9.2	2000	73.0	48.6	0.67	3.64	85.4	20.1	4.6
	18.0	6.4	14.7	1800	68.9	5.32	50.7	105.4	3.79	10.3	1800	72.2	45.2	0.63	3.35	83.7	21.5	4.0
60	12.0	3.0	7.0	2000	71.1	5.50	52.4	102.9	3.79	9.4	2000	73.6	49.1	0.67	3.57	85.8	20.7	4.4
	15.0	4.5	10.5	1800	70.1	5.39	51.7	106.1	3.81	10.6	1800	73.0	46.1	0.63	3.30	84.2	22.1	3.7
	18.0	6.2	14.2	2000	72.4	5.55	53.5	103.5	3.82	9.7	2000	74.4	49.6	0.67	3.51	86.4	21.2	4.2
70	12.0	2.9	6.8	1800	74.1	5.46	55.5	108.1	3.98	11.1	1800	67.7	43.8	0.65	3.74	80.4	18.1	5.3
	15.0	4.4	10.2	2000	76.5	5.57	57.5	105.4	4.03	10.3	2000	69.1	47.3	0.68	3.98	82.6	17.4	5.6
	18.0	6.0	13.8	1800	77.3	5.57	58.4	109.8	4.08	11.5	1800	68.3	44.2	0.65	3.67	80.8	18.6	4.9
80	12.0	2.8	6.5	2000	79.9	5.64	60.6	107.0	4.15	10.6	2000	69.7	47.8	0.69	3.89	83.0	17.9	5.3
	15.0	4.3	9.8	1800	79.1	5.62	59.9	110.7	4.13	11.8	1800	69.1	44.9	0.65	3.60	81.4	19.2	4.6
	18.0	5.7	13.3	2000	81.7	5.70	62.3	107.8	4.20	10.9	2000	70.5	48.3	0.69	3.84	83.5	18.4	5.1
90	12.0	2.7	6.3	1800	82.9	5.68	63.5	112.7	4.28	12.5	1800	63.8	42.8	0.67	4.06	77.7	15.7	6.6
	15.0	4.1	9.5	2000	84.7	5.88	64.6	109.2	4.22	11.6	2000	65.2	46.0	0.71	4.32	79.9	15.1	7.0
	18.0	5.5	12.8	1800	85.9	5.77	66.2	114.2	4.36	12.9	1800	64.5	43.2	0.67	3.98	78.0	16.2	6.2
100	12.0	2.6	6.1	2000	88.6	5.78	68.8	111.0	4.49	11.9	2000	65.8	46.5	0.71	4.22	80.2	15.6	6.7
	15.0	4.0	9.1	1800	88.1	5.85	68.1	115.3	4.42	13.3	1800	65.2	43.7	0.67	3.90	78.5	16.7	5.7
	18.0	5.3	12.3	2000	91.0	5.85	71.0	112.1	4.56	12.3	2000	66.5	47.0	0.71	4.16	80.7	16.0	6.4
110	12.0	2.5	5.8	1800	87.8	6.00	67.3	115.2	4.29	14.1	1800	60.6	40.9	0.67	4.52	76.0	13.4	8.4
	15.0	3.8	8.8	2000	91.1	6.03	70.5	112.2	4.43	13.0	2000	61.9	44.2	0.71	4.80	78.3	12.9	8.9
	18.0	5.1	11.9	1800	90.3	6.15	69.3	116.5	4.30	14.5	1800	61.2	41.3	0.67	4.42	76.3	13.8	7.8
120	12.0	2.4	5.6	2000	93.2	6.07	72.5	113.1	4.50	13.4	2000	62.5	44.6	0.71	4.71	78.5	13.3	8.4
	15.0	3.7	8.4	1800	93.1	6.23	71.8	117.9	4.38	15.0	1800	61.9	41.9	0.68	4.35	76.7	14.2	7.2
	18.0	4.9	11.4	2000	96.1	6.14	75.2	114.5	4.59	13.8	2000	63.2	45.1	0.71	4.63	78.9	13.6	8.0
130	12.0	2.3	5.5	1800	93.5	6.46	71.4	118.1	4.24	15.8	1800	57.4	38.9	0.68	4.97	74.4	11.5	10.5
	15.0	3.5	8.2	2000	96.6	6.33	75.0	114.7	4.47	14.7	2000	58.6	42.3	0.72	5.29	76.7	11.1	11.1
	18.0	4.8	11.1	1800	94.8	6.53	72.5	118.8	4.25	16.3	1800	58.0	39.3	0.68	4.87	74.6	11.9	9.8
140	12.0	2.2	5.3	2000	97.9	6.36	76.2	115.3	4.51	15.1	2000	59.2	42.7	0.72	5.19	76.9	11.4	10.6
	15.0	3.3	8.0	1800	98.0	6.62	75.5	120.4	4.34	16.8	1800	59.8	41.5	0.69	4.98	76.8	12.0	9.1
	18.0	4.5	10.5	2000	101.3	6.43	79.4	116.9	4.62	15.6	2000	59.8	43.1	0.72	5.10	77.2	11.7	10.1
150	12.0	2.1	5.1	Operation not recommended							Operation not recommended							
	15.0	3.0	7.8	Operation not recommended							Operation not recommended							
	18.0	4.0	10.5	1800	50.9	36.0	0.71	6.03	71.4	8.4	14.9	1800	54.4	37.6	0.69	5.45	73.0	10.0
160	12.0	2.0	4.9	Operation not recommended							Operation not recommended							
	15.0	2.9	7.6	Operation not recommended							Operation not recommended							
	18.0	3.8	10.3	2000	51.9	38.7	0.75	6.41	73.8	8.1	16.1	2000	55.5	40.7	0.73	5.80	75.3	9.6
170	12.0	1.9	4.7	Operation not recommended							Operation not recommended							
	15.0	2.8	7.4	Operation not recommended							Operation not recommended							
	18.0	3.7	10.1	1800	51.4	36.4	0.71	5.92	71.7	8.7	13.8	1800	55.0	38.2	0.69	5.36	73.3	10.3
180	12.0	1.8	4.5	Operation not recommended							Operation not recommended							
	15.0	2.7	7.2	Operation not recommended							Operation not recommended							
	18.0	3.6	9.9	2000	52.5	39.1	0.74	6.30	74.0	8.3	15.3	2000	56.2	41.1	0.73	5.70	75.6	9.9
190	12.0	1.7	4.3	Operation not recommended							Operation not recommended							
	15.0	2.6	7.0	Operation not recommended							Operation not recommended							
	18.0	3.5	9.7	1800	48.5	36.8	0.76	6.95	72.3	7.0	18.0	1800	48.5	36.8	0.76	6.95	72.3	7.0
200	12.0	1.6	4.1	Operation not recommended							Operation not recommended							
	15.0	2.5	6.8	Operation not recommended							Operation not recommended							
	18.0	3.4	9.5	2000	49.4	39.9	0.81	7.13	73.8	6.9	19.5	2000	49.4	39.9	0.81	7.13	73.8	6.9
210	12.0	1.5	3.9	Operation not recommended							Operation not recommended							
	15.0	2.4	6.6	Operation not recommended							Operation not recommended							
	18.0	3.3	9.3	1800	49.0	36.8	0.75	6.73	71.9	7.3	16.7	1800	49.0	36.8	0.75	6.73	71.9	7.3
220	12.0	1.4	3.7	Operation not recommended							Operation not recommended							
	15.0	2.3	6.4	Operation not recommended							Operation not recommended							
	18.0	3.2	9.1	2000	50.0	39.9	0.80	6.94	73.7	7.2	18.5	2000	50.0	39.9	0.80	6.94	73.7	7.2

Multiple Flow Rates (for EWT) are shown in the table above. The lowest flow rate shown is used for geothermal open loop/well water systems with a minimum 50° F. The second flow rate shown is the minimum geothermal closed loop flow rate. The third flow rate shown is optimum for geothermal closed loop and the suggested flow rate for boiler tower applications. 3/7/17

The manufacturer works continually to improve its products. As a result, the design and specifications of each product at the time of order may be changed without notice. Purchaser's approval of this data set signifies that the equipment is acceptable under the provisions of the job specification. Statements and other information contained herein are not express warranties and do not form the basis of any bargain between the parties, but are merely the manufacturer's opinion or commendation of its products. York and Affinity are registered trademarks of Johnson Controls, Inc., and are used with permission.



Contractor: \_\_\_\_\_ P.O.: \_\_\_\_\_  
 Engineer: \_\_\_\_\_  
 Project Name: \_\_\_\_\_ Unit Tag: \_\_\_\_\_



# Wiring Schematics

## Split Wiring Schematic - 208-230/60/1

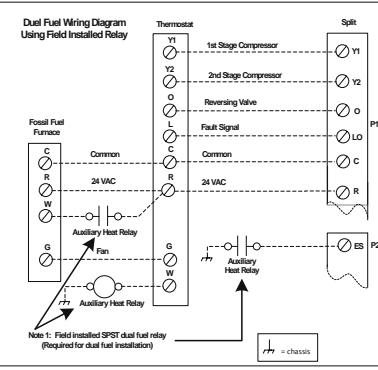
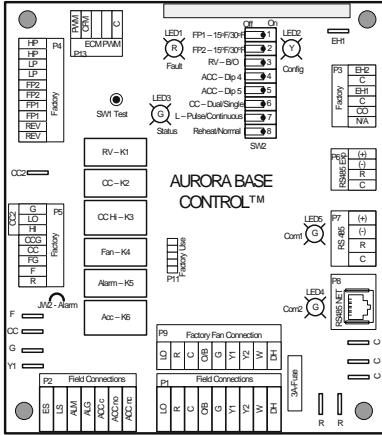

**Legend**

- Factory Low voltage wiring
- Factory Line voltage wiring
- Field low voltage wiring
- Field line voltage wiring
- Optional block
- DC Voltage PCB traces
- Junction
- Quick connect terminal
- Wire nut
- Field wire lug
- Ground
- Relay Contacts- N.O., N.C.
- Fuse
- Breaker
- Compressor Contactor
- Condensate overflow sensor
- DHW pump relay
- Loop pump relay
- PSC Fan Speed Relay
- PSC Fan Power Relay
- Compressor Solenoid
- Fuses
- HE - Heater element
- HP - High pressure switch
- FP1 - Freeze protection sensor
- LP - Low pressure switch
- Thermistor
- Light emitting diode - Green
- Relay coil
- Capacitor w/ bleed resistor
- Switch - Condensate overflow
- Switch - High pressure
- Switch - Low pressure
- Polarized connector
- Current Transducer (CT)
- Power block
- Power strip
- Reversing Valve coil
- DIP package 5 position AxB
- TEST MODE AxB Board
- DIP package 8 position ABC Board
- Thermal limit switch
- Hot water limit sensor
- Start Contactor
- Start Relay
- Water Coil Limit Sensor

**Notes**  
 1 - Field installed SPST relay required for dual fuel applications

Aurora Timing Events		
Event	Normal Mode	Test Mode
Random Start Delay	5 to 80 seconds	1 second
Compressor On Delay	5 seconds	< 1 second
Compressor Minimum On Time	2 minutes	5 seconds
Compressor Short Cycle Delay	4 minutes	15 seconds
Blower Off Delay	30 seconds	2 seconds
Fault Recognition Delay - High Pressure	Less than 1 second	Less than 1 second
Start-Up Bypass - Low Pressure	2 minutes	30 seconds
Fault Recognition Delay - Low Pressure	30 seconds	30 seconds
Start-Up Bypass - Low Water Coil Limit	2 minutes	30 seconds
Fault Recognition Delay - Low Water Coil Limit	30 seconds	30 seconds
Fault Recognition Delay - Condensate Overflow	30 seconds	30 seconds
Thermostat Call Recognition Time	2 seconds	2 seconds
Water Valve Slow Open Delay	30 seconds	30 seconds

ABC SW2 Accessory Relay		
DESCRIPTION	SW2-4	SW2-5
Cycle with Blower	ON	ON
Cycle with Compressor	OFF	OFF
Water Valve Slow Opening	ON	OFF
Cycle with Comm. 1-stat Hum Cmd	OFF	ON

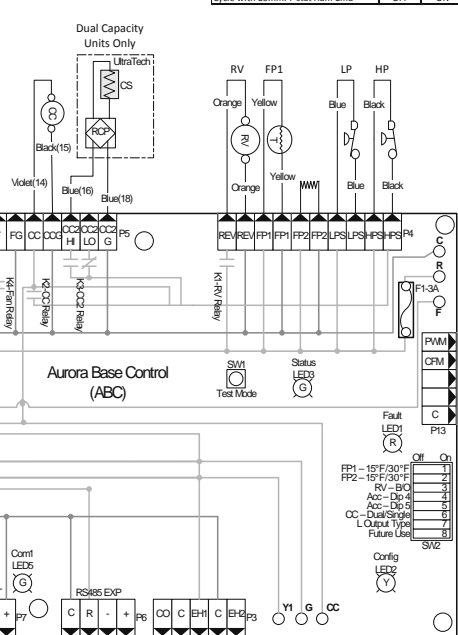
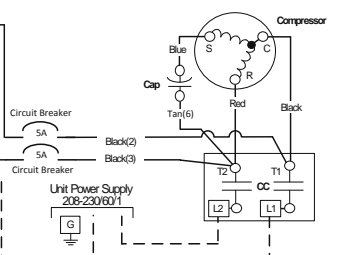
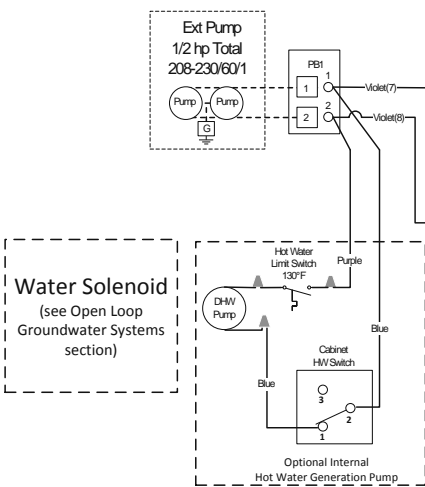

**Aurora LED Flash Codes**

Slow Flash: 1 second on and 1 second off  
 Fast Flash: 100 milliseconds on and 100 milliseconds off  
 Flash Code: 100 milliseconds on and 400 milliseconds off with a 2 second pause before repeating

Random Start Delay (Alternating Colors)	Configuration LED (LED2, Yellow)	Configuration LED (LED3, Red)	Status LED (LED3, Green)
Status LED (LED1, Green)	Fast Flash	No Software Overrides	OFF
Configuration LED (LED2, Yellow)	Fast Flash	DIP Switch Override	Slow Flash
Fault LED (LED3, Red)	Fast Flash		
Normal Mode		Status LED (LED3, Green)	
Normal Mode	OFF	Normal Mode	ON
Input Fault Lockout	Flash Code 1	Control is Non-Functional	OFF
High Pressure Lockout	Flash Code 2	Test Mode	Slow Flash
Low Pressure Lockout	Flash Code 3	Lockout Active	Fast Flash
Future Use	Flash Code 4	Dehumidification Mode	Flash Code 2
Freeze Detection - FP1	Flash Code 5	Future Use	Flash Code 3
Reserved	Flash Code 6	Future Use	Flash Code 4
Condensate Overflow Lockout	Flash Code 7	Load Shed	Flash Code 5
Over/Under Voltage Shutdown	Flash Code 8	ESD	Flash Code 6
Future Use	Flash Code 9	Future Use	Flash Code 7
Future Use	Flash Code 10	Future Use	Flash Code 8
FP1 Sensor Error	Flash Code 11	Future Use	Flash Code 9



The manufacturer works continually to improve its products. As a result, the design and specifications of each product at the time of order may be changed without notice. Purchaser's approval of this data set signifies that the equipment is acceptable under the provisions of the job specification. Statements and other information contained herein are not express warranties and do not form the basis of any bargain between the parties, but are merely the manufacturer's opinion or commendation of its products. York and Affinity are registered trademarks of Johnson Controls, Inc., and are used with permission.

Contractor: \_\_\_\_\_ P.O.: \_\_\_\_\_  
 Engineer: \_\_\_\_\_  
 Project Name: \_\_\_\_\_ Unit Tag: \_\_\_\_\_

**Affinity Single & Dual Capacity  
 Indoor Split Series  
 2 - 6 Tons 60Hz**



**Wiring Schematics cont.**

**Split Wiring Schematic with IntelliStart - 208-230/60/1**

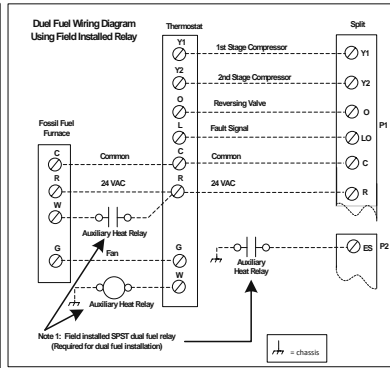
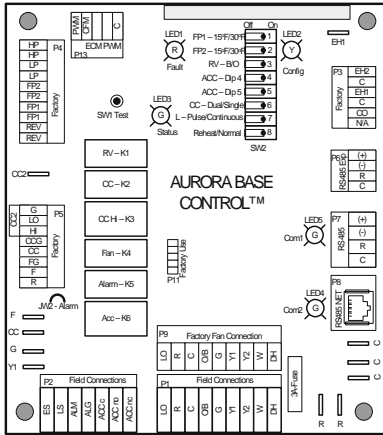

**Notes**  
 1 - Field installed SPST relay required for dual fuel applications

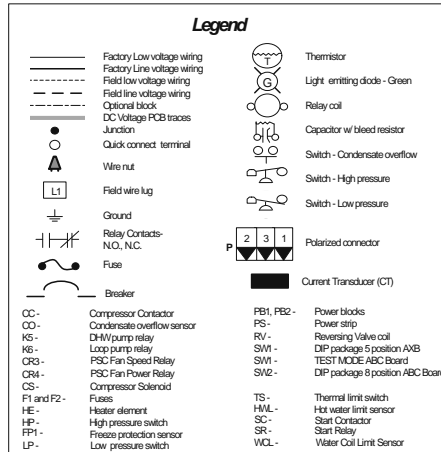

**Water Solenoid**  
 (see Open Loop Groundwater Systems section)

**Ext Pump**  
 1/2 hp Total  
 208-230/60/1

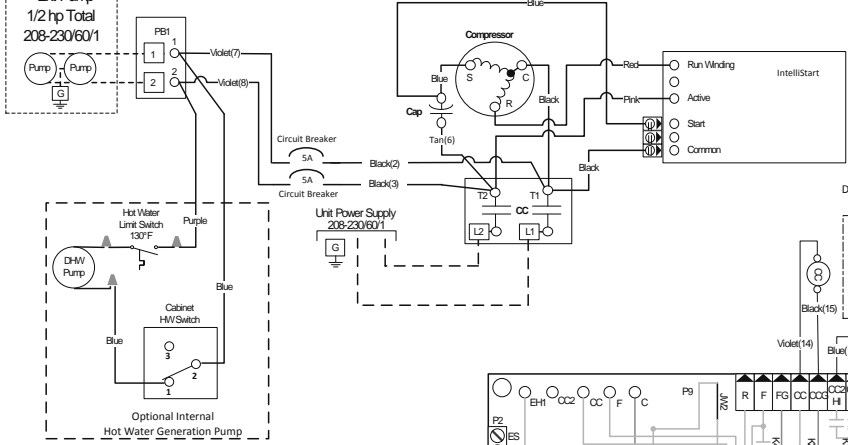

**Aurora Timing Events**

Event	Normal Mode	Test Mode
Random Start Delay	5 to 30 seconds	1 second
Compressor On Delay	5 seconds	< 1 second
Compressor Minimum On Time	2 minutes	5 seconds
Compressor Short Cycle Delay	4 minutes	15 seconds
Blower Off Delay	30 seconds	2 seconds
Fault Recognition Delay - High Pressure	Less than 1 second	Less than 1 second
Start-Up Bypass - Low Pressure	2 minutes	30 seconds
Fault Recognition Delay - Low Pressure	30 seconds	30 seconds
Start-Up Bypass - Low Water Coil Limit	2 minutes	30 seconds
Fault Recognition Delay - Low Water Coil Limit	30 seconds	30 seconds
Fault Recognition Delay - Condensate Overflow	30 seconds	30 seconds
Thermostat Call Recognition Time	2 seconds	2 seconds
Water Valve Slow Open Delay	90 seconds	90 seconds

**ABC SW2 Accessory Relay**

DESCRIPTION	SW2-4	SW2-5
Cycle with Blower	ON	ON
Cycle with Compressor	OFF	OFF
Water Valve Slow Opening	ON	OFF
Cycle with Comm. T-stat Hum Cmd	OFF	ON

**Aurora LED Flash Codes**

Slow Flash	1 second on and 1 second off
Fast Flash	100 milliseconds on and 100 milliseconds off
Flash Code	100 milliseconds on and 400 milliseconds off with a 2 second pause before repeating

Random Start Delay (Alternating Colors)	Configuration LED (LED2, Yellow)
Status LED (LED1, Green)	Fast Flash
Configuration LED (LED2, Yellow)	Fast Flash
Fault LED (LED3, Red)	Fast Flash

Fault LED (LED1, Red)	Status LED (LED3, Green)
Normal Mode	OFF
Input Fault Lockout	Flash Code 1
High Pressure Lockout	Flash Code 2
Low Pressure Lockout	Flash Code 3
Future Use	Flash Code 4
Frost Detection - FP1	Flash Code 5
Reserved	Flash Code 6
Condensate Overflow Lockout	Flash Code 7
Over/Under Voltage Shutdown	Flash Code 8
Future Use	Flash Code 9
Future Use	Flash Code 10
FP1 Sensor Error	Flash Code 11

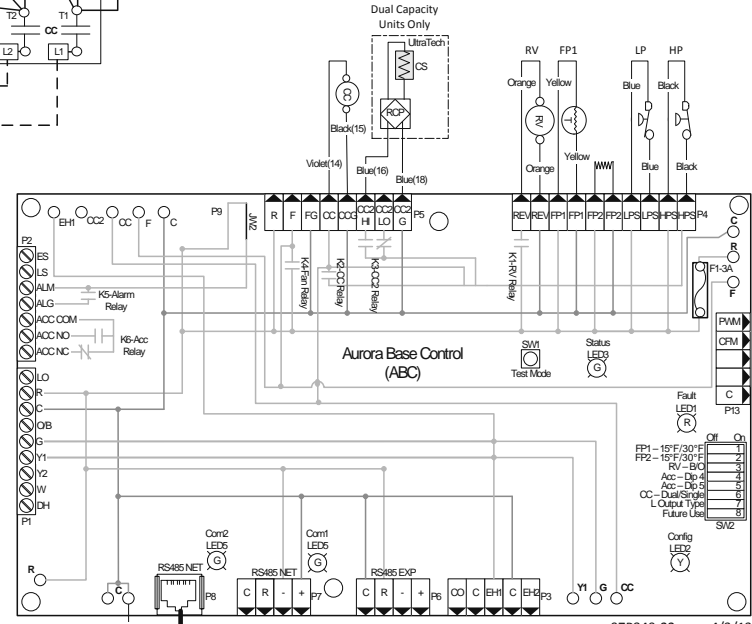

The manufacturer works continually to improve its products. As a result, the design and specifications of each product at the time of order may be changed without notice. Purchaser's approval of this data set signifies that the equipment is acceptable under the provisions of the job specification. Statements and other information contained herein are not express warranties and do not form the basis of any bargain between the parties, but are merely the manufacturer's opinion or commendation of its products. York and Affinity are registered trademarks of Johnson Controls, Inc., and are used with permission.

Contractor: \_\_\_\_\_ P.O.: \_\_\_\_\_  
 Engineer: \_\_\_\_\_  
 Project Name: \_\_\_\_\_ Unit Tag: \_\_\_\_\_



# Wiring Schematics cont.

## Aurora Advanced Controls

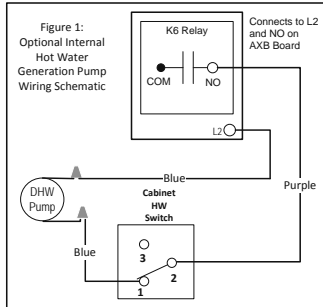
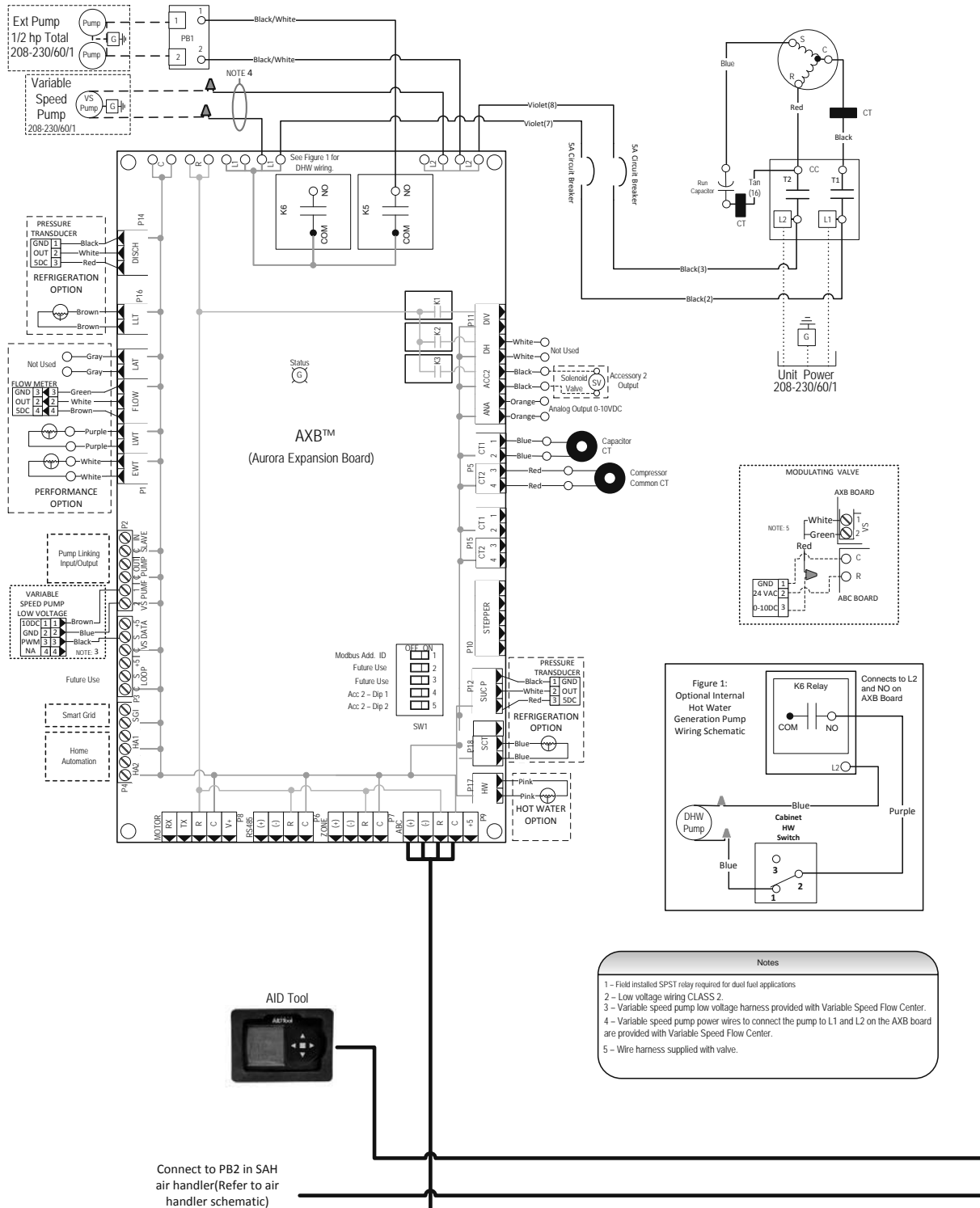

- Notes**
- 1 - Field installed SPST relay required for dual fuel applications
  - 2 - Low voltage wiring CLASS 2.
  - 3 - Variable speed pump low voltage harness provided with Variable Speed Flow Center.
  - 4 - Variable speed pump power wires to connect the pump to L1 and L2 on the AXB board are provided with Variable Speed Flow Center.
  - 5 - Wire harness supplied with valve.

Connect to PB2 in SAH air handler (Refer to air handler schematic)

The manufacturer works continually to improve its products. As a result, the design and specifications of each product at the time of order may be changed without notice. Purchaser's approval of this data set signifies that the equipment is acceptable under the provisions of the job specification. Statements and other information contained herein are not express warranties and do not form the basis of any bargain between the parties, but are merely the manufacturer's opinion or commendation of its products. York and Affinity are registered trademarks of Johnson Controls, Inc., and are used with permission.

Contractor: \_\_\_\_\_ P.O.: \_\_\_\_\_

Engineer: \_\_\_\_\_

Project Name: \_\_\_\_\_ Unit Tag: \_\_\_\_\_

**Affinity Single & Dual Capacity  
Indoor Split Series  
2 - 6 Tons 60Hz**



**Wiring Schematics cont.**

**Aurora Advanced Controls**

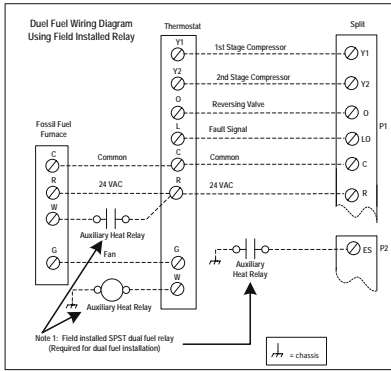
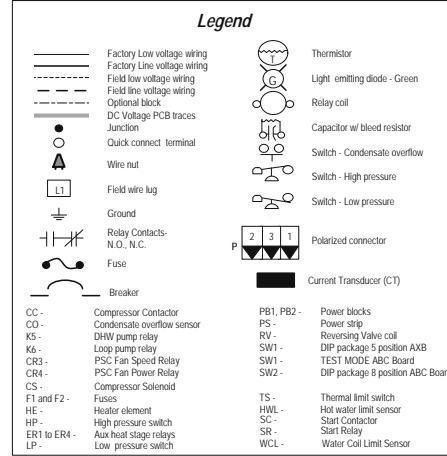
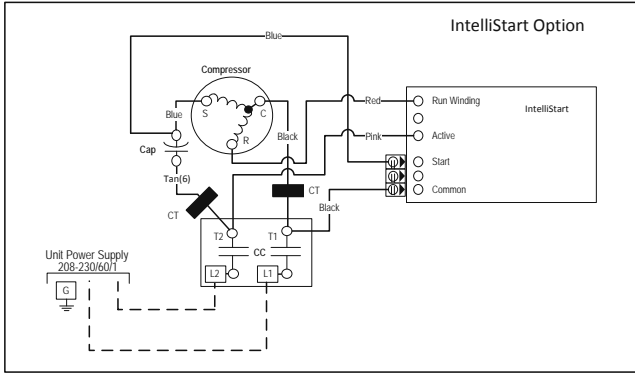

Aurora LED Flash Codes		
Slow Flash	1 second on and 1 second off	
Fast Flash	100 milliseconds on and 100 milliseconds off	
Flash Code	100 milliseconds on and 400 milliseconds off with a 2 second pause before repeating	
Random Start Delay (Alternating Colors)		Configuration LED (LED2, Yellow)
Status LED (LED1, Green)	Fast Flash	No Software Override
Status LED (LED2, Yellow)	Fast Flash	DIP Switch Override
Status LED (LED3, Red)	Fast Flash	Slow Flash
Fault LED (LED1, Red)		Status LED (LED3, Green)
Normal Mode	OFF	Normal Mode
Input Fault Lockout	Flash Code 1	Control is Non-Functional
High Pressure Lockout	Flash Code 2	Test Mode
Low Pressure Lockout	Flash Code 3	Lockout Active
Future Use	Flash Code 4	Dehumidification Mode
Freeze Detection - FP1	Flash Code 5	Future Use
Reserved	Flash Code 6	Future Use
Condensate Overflow Lockout	Flash Code 7	Load Shed
Over/Under Voltage Shutdown	Flash Code 8	ESD
Future Use	Flash Code 9	Future Use
Future Use	Flash Code 10	Future Use
EP1 Sensor Error	Flash Code 11	

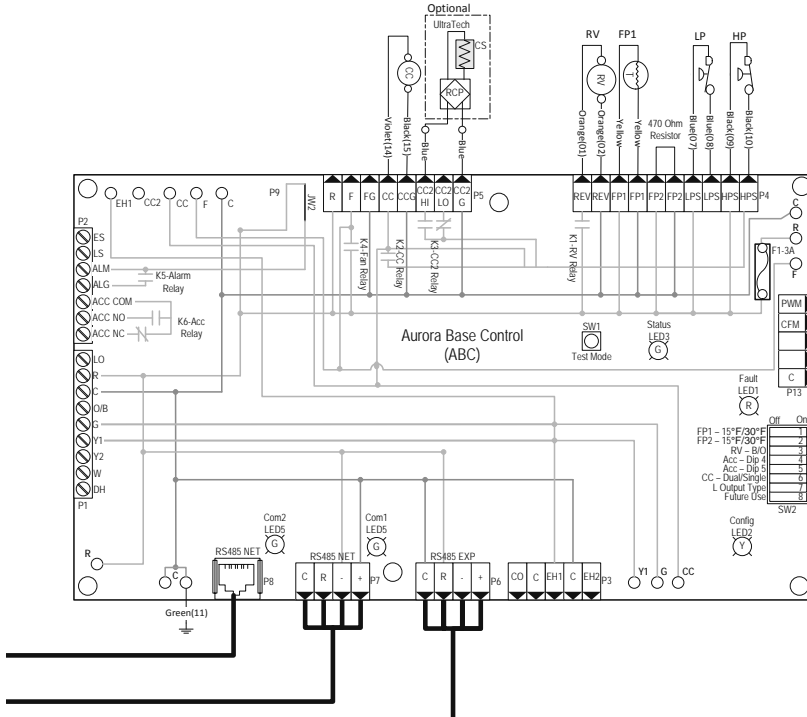

The manufacturer works continually to improve its products. As a result, the design and specifications of each product at the time of order may be changed without notice. Purchaser's approval of this data set signifies that the equipment is acceptable under the provisions of the job specification. Statements and other information contained herein are not express warranties and do not form the basis of any bargain between the parties, but are merely the manufacturer's opinion or commendation of its products. York and Affinity are registered trademarks of Johnson Controls, Inc., and are used with permission.

Contractor: \_\_\_\_\_ P.O.: \_\_\_\_\_

Engineer: \_\_\_\_\_

Project Name: \_\_\_\_\_ Unit Tag: \_\_\_\_\_

**Affinity Single & Dual Capacity  
Indoor Split Series  
2 - 6 Tons 60Hz**



## Engineering Guide Specifications

### General

Furnish and install Water Source Heat Pumps, as indicated on the plans. The geothermal heating/cooling units shall be reverse cycle split system configuration designed for use with DX heating and cooling coils. Units shall be AHRI/ISO 13256-1 certified and listed by a nationally recognized safety-testing laboratory or agency, such as ETL Testing Laboratory. Each unit shall be computer run-tested at the factory with conditioned water and operation verified to catalog data. Each unit shall be mounted on a pallet and shipped in a corrugated box or stretch-wrapped. The units shall be designed to operate with entering liquid temperature between 20°F and 120°F [-6.7°C and 48.9°C].

### Casing and Cabinet

The cabinet shall be fabricated from heavy-gauge galvanized steel and finished with corrosion-resistant powder coating. This corrosion protection system shall meet the stringent 1000 hour salt spray test per ASTM B117. The interior shall be insulated with 1/2-inch thick, multi-density, cleanable aluminum foil coated glass fiber with edges sealed or tucked under flanges. Standard cabinet panel insulation must meet NFPA 90A requirements, air erosion and mold growth limits of UL-181, stringent fungal resistance test per ASTM-C1071 and ASTM G21, and shall meet zero level bacteria growth per ASTM G22. Unit insulation must meet these stringent requirements or unit(s) will not be accepted.

### Refrigerant Circuit

All units shall contain a sealed refrigerant circuit including a hermetic motor-compressor, thermostatic expansion valve, reversing valve, coaxial tube water-to-refrigerant heat exchanger, compressor discharge muffler, accumulator, and service ports.

Compressors shall be high-efficiency scroll single speed or dual capacity type designed for heat pump duty and mounted on rubber vibration isolators. Compressor motors shall be single-phase PSC with overload protection.

The coaxial water-to-refrigerant heat exchanger shall be designed for low water pressure drop and constructed of a convoluted copper (cupronickel option) inner tube and a steel outer tube. Refrigerant to water heat exchangers shall be of copper inner water tube and steel refrigerant outer tube design, rated to withstand 600 psig (4135 kPa) working refrigerant pressure and 450 psig (3101 kPa) working water pressure. The thermostatic expansion valve shall provide proper superheat over the entire liquid temperature range with minimal "hunting."

All units shall have the source coaxial tube refrigerant-to-water heat exchanger and the optional hot water generator coil coated with ThermaShield. Refrigerant suction lines shall be insulated to prevent condensation at low liquid temperatures.

### Electrical

A control box shall be located within the unit compressor compartment and shall contain a 2 pole compressor contactor, circuit breakers for protecting loop pumps, terminal block for thermostat wiring, and solid-state controller for complete unit operation. Electromechanical operation WILL NOT be accepted. Units shall be name-plated for use with time delay fuses or HACR circuit breakers. Unit controls shall be 24 volt and provide heating or cooling as required by the remote thermostat/sensor. An Aurora, a microprocessor-based controller, interfaces with a multi-stage electronic thermostat to monitor and control unit operation shall be provided. The control shall provide operational sequencing, high and low pressure switch monitoring, freeze detection, hot water limit thermistor sensing, lockout mode control, hot water and loop pump control, LED status and fault indicators, fault memory, field selectable options, and accessory output. The Lockout signal output shall have a pulsed option so that DDC systems can read specific lockout conditions from the control.

A detachable terminal block with screw terminals will be provided for field control wiring. All units shall have knockouts for entrance of low and line voltage wiring. The control box shall be harness plug wired for easy removal.

An optional Aurora Interface Diagnostic (AID) Tool shall communicate with the Aurora control allowing quick and easy access to setup, monitoring, and troubleshooting of any Aurora control. The device shall include the features of fault description and history, manual operation capability, sensor readings, timings, and other diagnostic tools.

**Optional IntelliStart® (compressor Soft Starter)** shall be factory installed for use in applications that require low starting amps, reduced compressor start-up noise, off-grid, and improved start-up behavior. IntelliStart shall reduce normal starting current by 60% on 208/60/1 units.

### Piping

Supply and return water connections shall be 1 in. [25.4 mm] FPT brass swivel fittings, which provide a union and eliminate the need for pipe wrenches and sealants when making field connections. The optional hot water generator shall have sweat type connections. All water piping shall be insulated to prevent condensation at low liquid temperatures.

The manufacturer works continually to improve its products. As a result, the design and specifications of each product at the time of order may be changed without notice. Purchaser's approval of this data set signifies that the equipment is acceptable under the provisions of the job specification. Statements and other information contained herein are not express warranties and do not form the basis of any bargain between the parties, but are merely the manufacturer's opinion or commendation of its products. York and Affinity are registered trademarks of Johnson Controls, Inc., and are used with permission.



Contractor: \_\_\_\_\_ P.O.: \_\_\_\_\_

Engineer: \_\_\_\_\_

Project Name: \_\_\_\_\_ Unit Tag: \_\_\_\_\_

## **Engineering Guide Specifications cont.**

---

### **Options and Accessories**

#### **Cupronickel Heat Exchanger**

An optional cupronickel water-to-refrigerant heat exchanger shall be provided.

#### **Hot Water Generator**

An optional ThermaShield coated heat reclaiming hot water generator coil of vented double-wall copper construction suitable for potable water shall be provided. The coil and hot water circulating pump shall be factory mounted inside the unit with integral electronic high limit temperature monitoring and external on/off switch.

#### **Thermostat (field-installed)**

A multi-stage auto-changeover electronic digital thermostat shall be provided. The thermostat shall offer three heating and two cooling stages with precise temperature control. An OFF-HEAT-AUTO-COOL-EMERG system switch, OFF-AUTO blower switch, and indicating LEDs shall be provided. The thermostat shall display in °F or °C. The thermostat shall be a traditional 24 VAC type.

#### **Flow Center (field-installed)**

A self-contained module shall provide all liquid flow, fill and connection requirements for ground source closed loop systems up to 20 gpm. The pumps shall be wired to a power block located in the nearest unit. The heat pump units shall contain low voltage pump slaving control so that two units may share one flow center.

Contractor: \_\_\_\_\_ P.O.: \_\_\_\_\_

Engineer: \_\_\_\_\_

Project Name: \_\_\_\_\_ Unit Tag: \_\_\_\_\_

**Affinity Single & Dual Capacity  
Indoor Split Series  
2 - 6 Tons 60Hz**



## Revision Guide

---

Pages:	Description:	Date:	By:
All	Updated for SAH Release	31 Mar 2016	MA
All	First Published	03 Sept 2013	DS