



Heating and Air Conditioning

SPECIFICATION MANUAL
AFFINITY YDL SERIES
**COMMERCIAL GEOTHERMAL/
WATER SOURCE HEAT PUMPS**
SINGLE AND DUAL CAPACITY

MODELS:

HORIZONTAL: YDL084-180
(7-15 NOMINAL TONS)

VERTICAL: YDL084-360
(7-30 NOMINAL TONS)



Due to continuous product improvement, specifications are subject to change without notice.

Visit us on the web at www.yorkgeothermal.com

Additional rating information can found at www.ahrirectory.org

Table of Contents

Model Nomenclature	4
Electrical Availability	4
AHRI Data	5
The YDL Series	7
Inside the YDL Series.....	14
Controls	17
Application Notes	26
Water Quality	22
Installation Notes	29
Dimensional Data	32
Physical Data	35
Electrical Availability	32
Electrical Data	36
Blower Performance Data	37
Selection Example	41
Reference Calculations	43
Legend and Notes	43
Operating Limits	44
Pressure Drop	45
Performance Data	46
Wiring Schematics	74
Engineering Guide Specifications.....	92
Revision Guide	95

Model Nomenclature

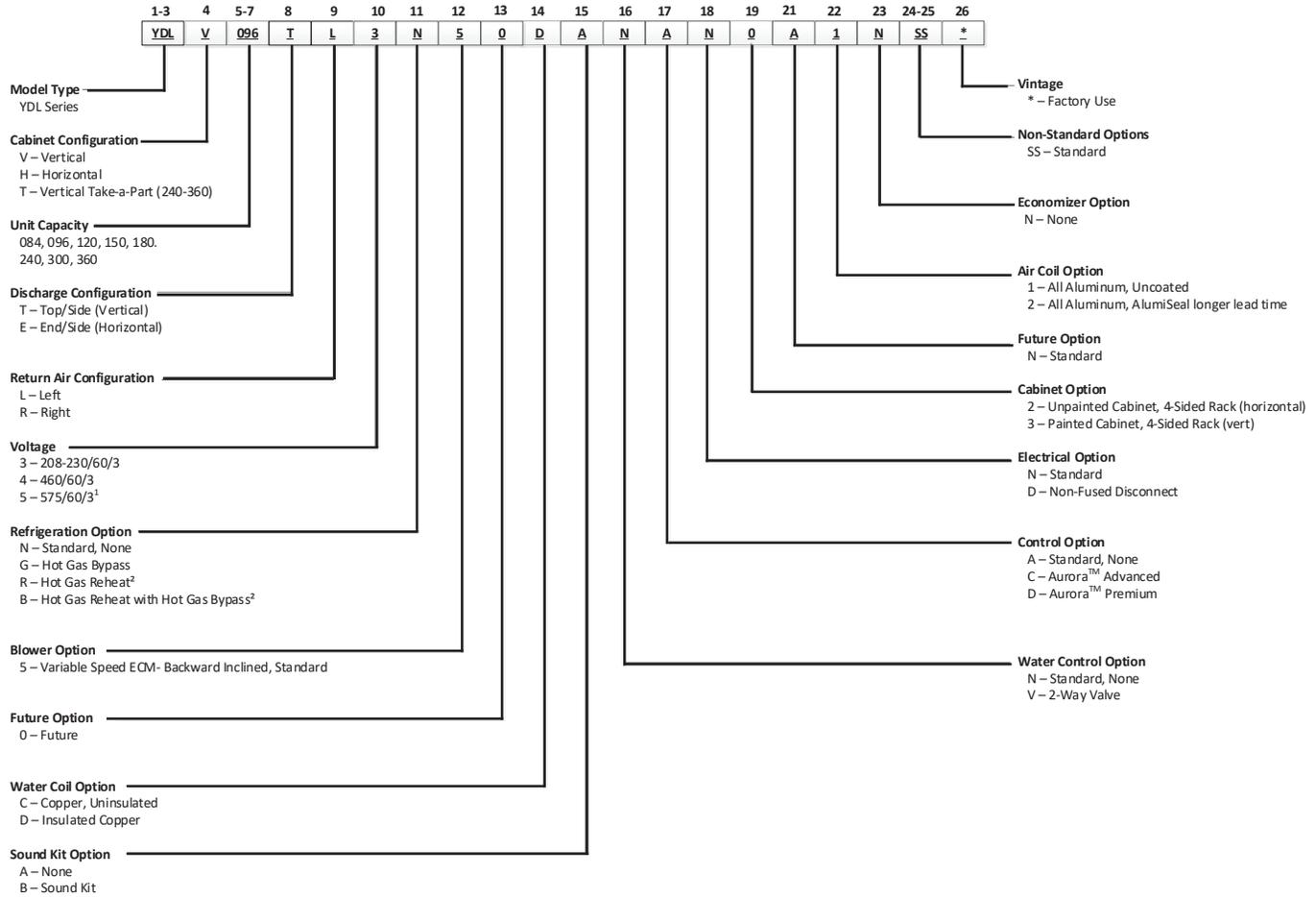

Note:
1- 575V option requires a power transformer.
2- Not available on H180
* Row meter externally mounted.
** EEV only available with Premium Controls

Electrical Availability

Voltage	Dual Capacity Compressor		
	084	096	120
208-230/60/3	●	●	●
460/60/3	●	●	●
575/60/3	●	●	●

Voltage	Two Compressor				
	150	180	240	300	360
208-230/60/3	●	●	●	●	●
460/60/3	●	●	●	●	●
575/60/3	●	●	●	●	●

● - Available

3/30/21

AHRI Data

AHRI/ASHRAE/ISO 13256-1 (Vertical) English (IP) Units

Model	Capacity Modulation	Flow Rate		Water Loop Heat Pump				Ground Water Heat Pump				Ground Loop Heat Pump			
				Cooling EWT 86°F		Heating EWT 68°F		Cooling EWT 59°F		Heating EWT 50°F		Cooling Brine Full Load 77°F Part Load 68°F		Heating Brine Full Load 32°F Part Load 41°F	
		gpm	cfm	Capacity Btuh	EER Btuh/W	Capacity Btuh	COP	Capacity Btuh	EER Btuh/W	Capacity Btuh	COP	Capacity Btuh	EER Btuh/W	Capacity Btuh	COP
084	Full	21	2500	86,000	16.0	103,600	5.0	98,000	24.0	84,000	4.4	90,000	18.5	67,000	3.8
	Part	14	1750	58,000	17.0	65,000	5.2	67,000	31.0	54,000	4.5	64,000	25.0	48,500	4.0
096	Full	24	2800	95,000	15.3	120,000	5.0	106,000	22.0	96,000	4.4	98,000	17.0	76,000	3.8
	Part	16	1900	63,000	16.4	75,000	5.2	73,000	28.5	60,000	4.5	69,000	23.5	53,000	4.0
120	Full	30	3600	119,000	14.5	140,000	5.0	135,000	21.0	114,000	4.2	123,000	16.5	89,000	3.5
	Part	20	2400	76,000	15.2	86,500	5.1	91,000	26.0	70,000	4.3	85,000	22.0	58,000	3.6
150	Full	36	4500	150,000	15.6	160,000	4.6	165,000	22.0	130,000	4.1	156,000	17.3	105,000	3.2
	Part	18	2300	75,000	16.0	80,000	5.0	82,500	23.0	65,000	4.5	78,000	19.0	52,500	4.0
180	Full	45	5200	180,000	14.0	195,000	4.3	190,000	18.0	162,000	3.8	184,000	15.2	128,000	3.2
	Part	28	2800	87,000	15.0	91,500	4.6	95,000	21.0	75,000	4.0	93,000	18.5	66,000	3.6
240	Full	60	7500	240,000	16.0	285,000	5.0	275,000	23.5	228,000	4.4	252,000	18.2	190,000	3.8
	Part	35	5400	130,000	17.5	148,000	5.6	145,000	25.0	118,000	4.8	140,000	23.0	100,000	4.2
300	Full	75	9000	300,000	15.0	350,000	4.6	342,000	23.0	290,000	4.1	315,000	17.2	230,000	3.7
	Part	40	6500	150,000	17.0	175,000	5.0	171,000	24.0	145,000	4.5	157,500	18.0	115,000	4.0
360	Full	90	9900	350,000	12.1	400,000	4.0	400,000	17.0	340,000	3.8	355,000	14.0	270,000	3.3
	Part	45	7500	175,000	12.4	222,000	4.2	190,000	18.4	170,000	4.0	180,000	16.5	140,000	3.5

Cooling capacities based upon 80.6°F DB, 66.2°F WB entering air temperature

Heating capacities based upon 68°F DB, 59°F WB entering air temperature

All ratings based upon 208V operation

Models 084-120 are rated and certified in accordance with ISO/AHRI/ASHRAE 13256-1

Models 150-360 are rated in accordance with ISO/AHRI/ASHRAE 13256-1 but are not certified since their capacity exceeds the scope of the AHRI program.

3/30/21

AHRI/ASHRAE/ISO 13256-1 (Horizontal) English (IP) Units

Model	Capacity Modulation	Flow Rate		Water Loop Heat Pump				Ground Water Heat Pump				Ground Loop Heat Pump			
				Cooling EWT 86°F		Heating EWT 68°F		Cooling EWT 59°F		Heating EWT 50°F		Cooling Brine Full Load 77°F Part Load 68°F		Heating Brine Full Load 32°F Part Load 41°F	
		gpm	cfm	Capacity Btuh	EER Btuh/W	Capacity Btuh	COP	Capacity Btuh	EER Btuh/W	Capacity Btuh	COP	Capacity Btuh	EER Btuh/W	Capacity Btuh	COP
H084	Full	21	2500	85,000	15.0	96,000	4.5	96,000	22.0	82,500	4.3	88,000	17.5	67,000	3.6
	Part	14	1750	57,500	16.0	65,000	5.1	66,500	29.0	54,000	4.4	64,000	24.0	48,500	4.0
H096	Full	24	2800	95,000	14.5	108,000	4.8	106,000	21.0	93,000	4.4	97,000	16.5	76,000	3.7
	Part	16	1900	63,000	16.0	74,000	5.0	73,000	28.0	60,000	4.3	69,000	23.0	53,000	3.9
H120	Full	30	3600	117,000	14.5	140,000	5.0	130,000	21.0	114,000	4.2	123,000	16.5	89,000	3.5
	Part	20	2400	76,000	15.2	86,500	5.0	90,000	26.0	70,000	4.3	85,000	22.0	58,000	3.6
H150	Full	36	4500	148,000	15.4	160,000	4.6	163,000	22.0	130,000	4.1	155,000	17.0	105,000	3.2
	Part	18	2300	74,000	15.5	80,000	4.9	81,000	23.0	65,000	4.3	76,000	18.0	52,500	4.0
H180	Full	45	5200	178,000	13.8	192,000	4.3	187,000	17.5	162,000	3.7	182,000	15.0	128,000	3.2
	Part	28	2800	85,000	14.8	90,000	4.5	94,000	20.0	75,000	4.0	91,000	18.0	66,000	3.6

Cooling capacities based upon 80.6°F DB, 66.2°F WB entering air temperature

Heating capacities based upon 68°F DB, 59°F WB entering air temperature

All ratings based upon 208V operation

Models 084-120 are rated and certified in accordance with ISO/AHRI/ASHRAE 13256-1

Models 150-360 are rated in accordance with ISO/AHRI/ASHRAE 13256-1 but are not certified since their capacity exceeds the scope of the AHRI program.

3/30/21



All YDL Series product is safety listed under UL1995 thru UL and performance tested in accordance with AHRI/ISO standard 13256-1.

AHRI Data cont.

The performance standard AHRI/ASHRAE/ISO 13256-1 became effective January 1, 2000 and replaces AHRI Standards 320, 325, and 330. This new standard has three major categories: Water Loop (comparable to ARI 320), Ground Water (ARI 325), and Ground Loop (ARI 330). Although these standards are similar there are some differences:

Unit of Measure: The Cooling COP

The cooling efficiency is measured in EER (US version measured in Btu/h per Watt. The Metric version is measured in a cooling COP (Watt per Watt) similar to the traditional COP measurement.

Water Conditions Differences

Entering water temperatures have changed to reflect the centigrade temperature scale. For instance the water loop heating test is performed with 68°F (20°C) water rounded down from the old 70°F (21.1°C).

Air Conditions Differences

Entering air temperatures have also changed (rounded down) to reflect the centigrade temperature scale. For instance the cooling tests are performed with 80.6°F (27°C) dry bulb and 66.2°F (19°C) wet bulb entering air instead of the traditional 80°F (26.7°C) DB and 67°F (19.4°C) WB entering air temperatures. 80.6/66.2 data may be converted to 80/67 using the entering air correction table. This represents a significantly lower relative humidity than the old 80/67 of 50% and will result in lower latent capacities.

Pump Power Correction Calculation

Within each model, only one water flow rate is specified for all three groups and pumping Watts are calculated using the following formula. This additional power is added onto the existing power consumption.

- Pump power correction = (gpm x 0.0631) x (Press Drop x 2990) / 300

Where 'gpm' is waterflow in gpm and 'Press Drop' is the pressure drop through the unit heat exchanger at rated water flow in feet of head.

Blower Power Correction Calculation

Blower power is corrected to zero external static pressure using the following equation. The nominal airflow is rated at a specific external static pressure. This effectively reduces the power consumption of the unit and increases cooling capacity but decreases heating capacity. These Watts are significant enough in most cases to increase EER and COPs fairly dramatically over ARI 320, 325, and 330 ratings.

- Blower Power Correction = (cfm x 0.472) x (esp x 249) / 300

Where 'cfm' is airflow in cfm and 'esp' is the external static pressure at rated airflow in inches of water gauge.

ISO Capacity and Efficiency Calculations

The following equations illustrate cooling calculations:

- ISO Cooling Capacity = Cooling Capacity (Btu/h) + (Blower Power Correction (Watts) x 3.412)
- ISO EER Efficiency (W/W) = ISO Cooling Capacity (Btu/h) x 3.412 / [Power Input (Watts) - Blower Power Correction (Watts) + Pump Power Correction (Watt)]

The following equations illustrate heating calculations:

- ISO Heating Capacity = Heating Capacity (Btu/h) - (Blower Power Correction (Watts) x 3.412)
- ISO COP Efficiency (W/W) = ISO Heating Capacity (Btu/h) x 3.412 / [Power Input (Watts) - Blower Power Correction (Watts) + Pump Power Correction (Watt)]

Comparison of Test Conditions

	ARI 320	ISO/AHRI 13256-1 WLHP	ARI 325	ISO/AHRI 13256-1 GWHP	ARI 330	ISO/AHRI 13256-1 GLHP
Cooling						
Entering Air - DB/WB °F	80/67	80.6/66.2	80/67	80.6/66.2	80/67	80.6/66.2
Entering Water - °F	85	86	50/70	59	77	77
Fluid Flow Rate	*	**	**	**	**	**
Heating						
Entering Air - DB/WB °F	70	68	70	68	70	68
Entering Water - °F	70	68	50/70	50	32	32
Fluid Flow Rate	*	**	**	**	**	**

Note *: Flow rate is set by 10°F rise in standard cooling test

Note **: Flow rate is specified by the manufacturer

Part load entering water conditions not shown.

WLHP = Water Loop Heat Pump; GWHP = Ground Water Heat Pump; GLHP = Ground Loop Heat Pump

Conversions:

Airflow (lps) = cfm x 0.472;

Water Flow (lps) = gpm x 0.0631;

esp (Pascals) = esp (in wg) x 249;

Press Drop (Pascals) = Press Drop (ft hd) x 2990

The YDL Series

The YDL Series is the latest upgrade to the large water-to-air packaged heat pumps featuring industry leading capabilities in some of the most compact cabinets on the market. With high efficiency dual and single capacity scroll compressors and standard Variable Speed integrated ECM plenum fan, the YDL introduces performance, technology, and innovation at a cost competitive price point. The reduced footprint and take-a-part cabinet option make this product suitable for both retrofit and new construction applications and provides optimum performance and flexibility in both water loop and geothermal applications.

The YDL is available in capacity sizes from 7 to 30 ton in 5 vertical and horizontal cabinet configurations. 7-10 ton models are equipped with Copeland Scroll dual capacity compressor and up to 41% reduced cabinet. 12-30-ton units have two single stage Copeland Scroll compressors and take-a-part design (240-360 models) that allows the unit to simply be separated in the field for jobs with not much room to maneuver. Variable Speed integrated ECM plenum fan is standard on all YDL models and sizes, providing high static capabilities while eliminating high maintenance and failure prone belts and sheaves.

The YDL is managed by a sophisticated Aurora Control system that is modular and designed for the most demanding applications. The Aurora Control features a microprocessor control to sequence all components during operation for optimum performance. Plus, it provides easy-to-use troubleshooting features with fault lights, on-board diagnostics, and a handheld Aurora Interface Diagnostic (AID) Tool. The Aurora system includes advanced loop and hot water generator pump control, as well as service, performance, and energy monitoring sensor kit capability.



Vertical Series

Models 084-360 (7-30 tons) Two-Stage Speed



Horizontal Series

Models 084-180 (7-15 tons) Two-Stage Speed



The YDL Series cont.

Product Highlights

The new product also features the following options (see nomenclature for more details)

- Capacity sizes from 7 to 30 ton
- Compact cabinet design
- Take-a-part capabilities (20-30 ton)
- 3 vertical (7-30 ton) and 2 horizontal (7-15 ton) cabinet configurations
- Complete commercial voltage selection of 208-230 V/60 Hz/3ph, 460/60/3, and 575/60/3
- All-Aluminum rifled tube-and-fin air coils are not susceptible to formicary corrosion
- All-Aluminum interlaced air coils (12-30 ton)
- Industry leading quality through engineering and manufacturing using quality components
 - High Efficiency and reliable permanent magnet dual and single capacity scroll compressors
 - High Efficiency variable speed, backward inclined plenum fan with 2" w.g. ESP capability
- High efficiency performance for maximizing LEED points
- Split access panel design for ease of service.
- Coaxial water to refrigerant heat exchanger eliminates the need for water straining and holds up in open tower environments.
- Optional Electronic expansion device with stepper motor, in-line valve design operated by direct drive motor technology. (Advanced EEV)

Flexible Product with Several Standard Options

- Extended range insulation
- Super Quiet Sound Package, including multi-density compressor blanket
- Quiet softstart scroll compressors in all models
- Double isolated compressor mounting utilizing eight durometer selected rubber grommets
- Configurations - horizontal left and right return, end or side discharge (field switchable); vertical left and right return
- Heavy gauge cabinet
- Hot Gas Bypass
- Standard Aurora Base Control
- Optional non-fused disconnect
- Stainless steel drain pan
- Energy monitoring allows the complete power usage of the entire unite to be measured and displayed.
- Refrigerant monitoring allows the measurement of discharge and suction pressures, suction and liquid line temperatures, superheat and subcooling.

Other options are available by special request through factory authorized representative.

The YDL Series cont.

Product Features: Vertical Cabinet

Vertical units are designed for high efficiency, maximum flexibility, and primary servicing from the front. Available in 3 cabinets for top/side discharge configurations.

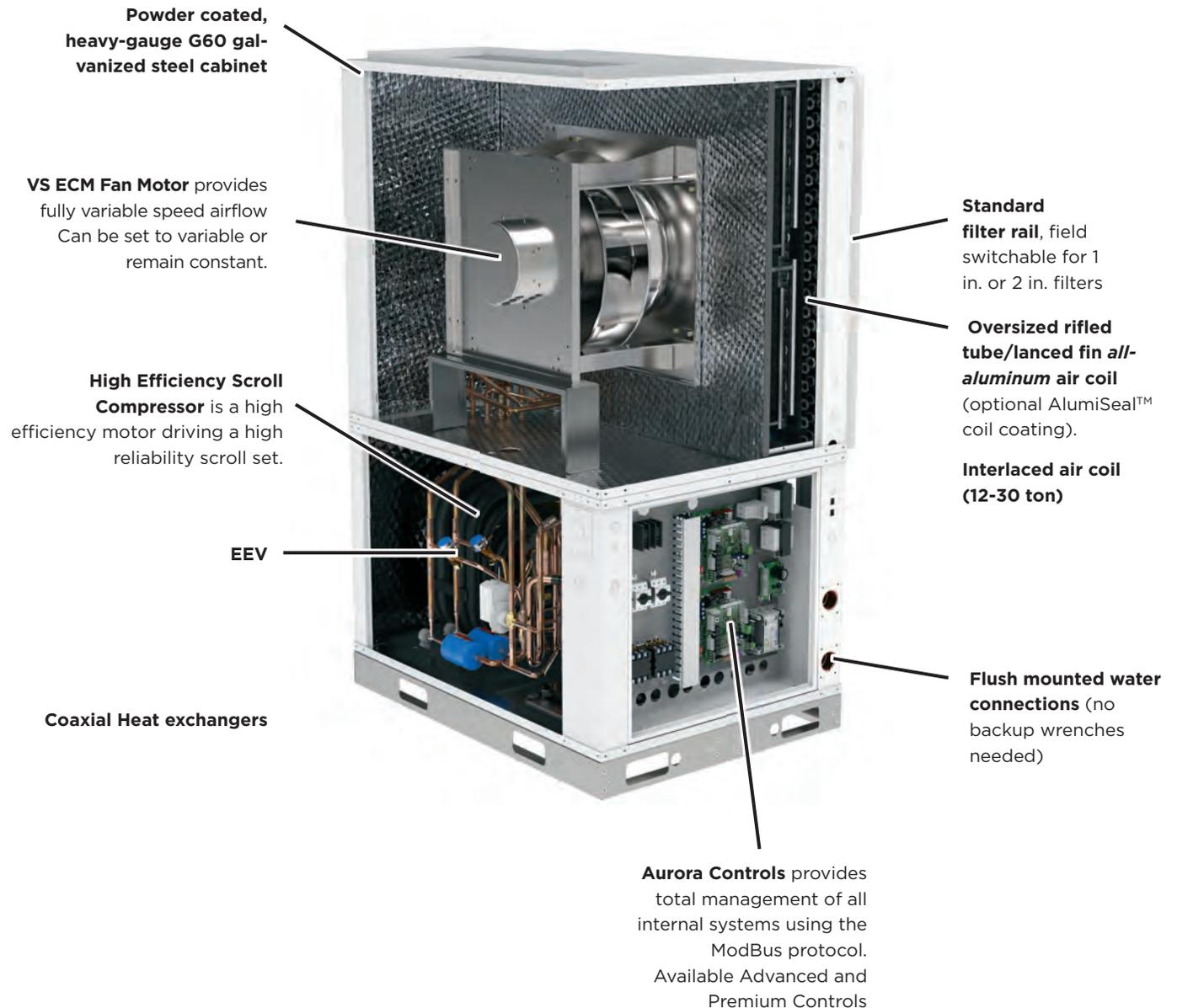

A true left and right return option is available.

The YDL Series cont.

Product Features: Horizontal Cabinet

Horizontal units are available in two cabinet sizes. The cabinets are designed for high efficiency, maximum flexibility, and primary servicing from the front.

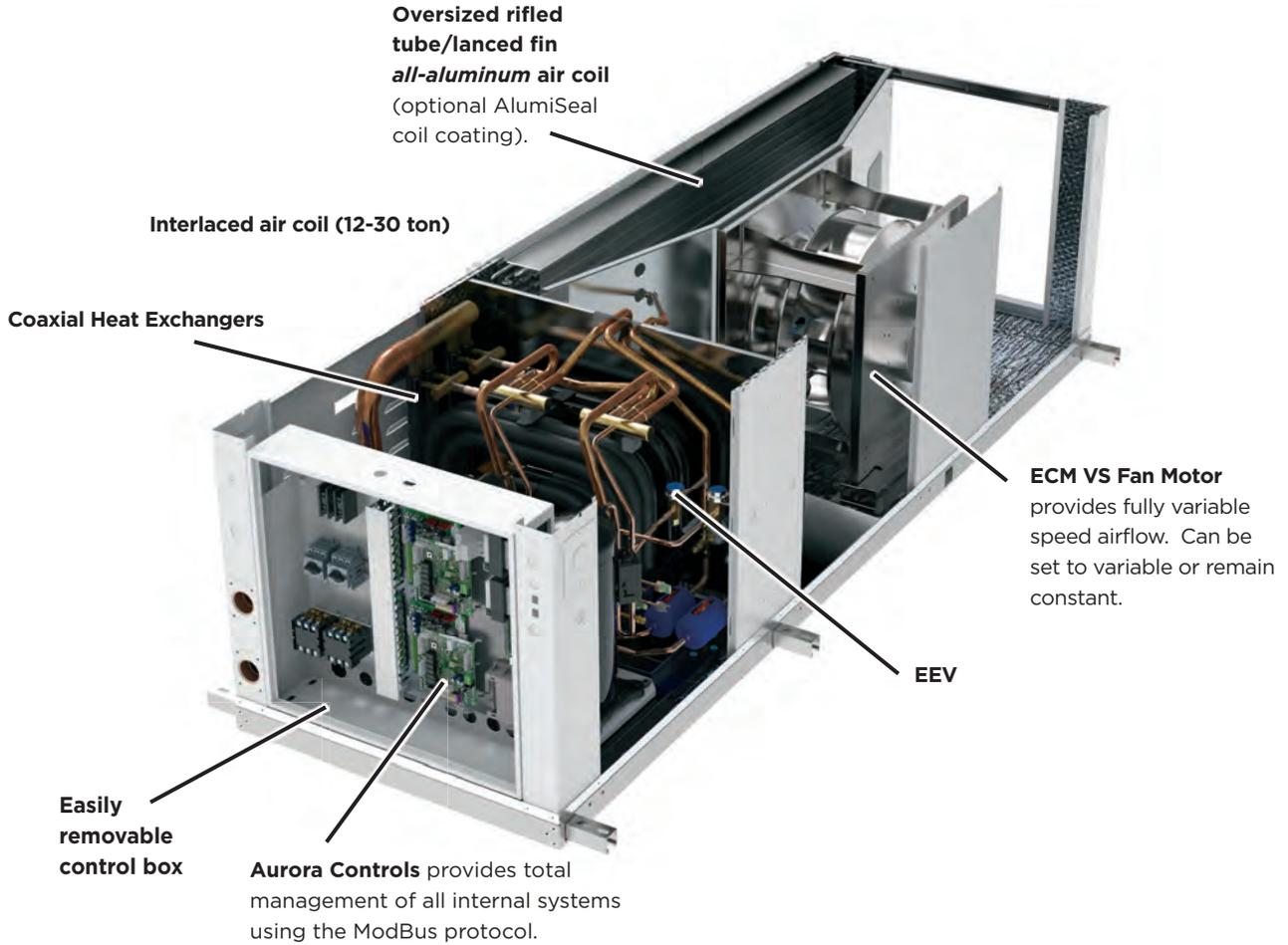

Four blower discharge options are available. Factory or field conversion option of end or side discharge using switchable access panels and a factory only option of true left or right return air coil.

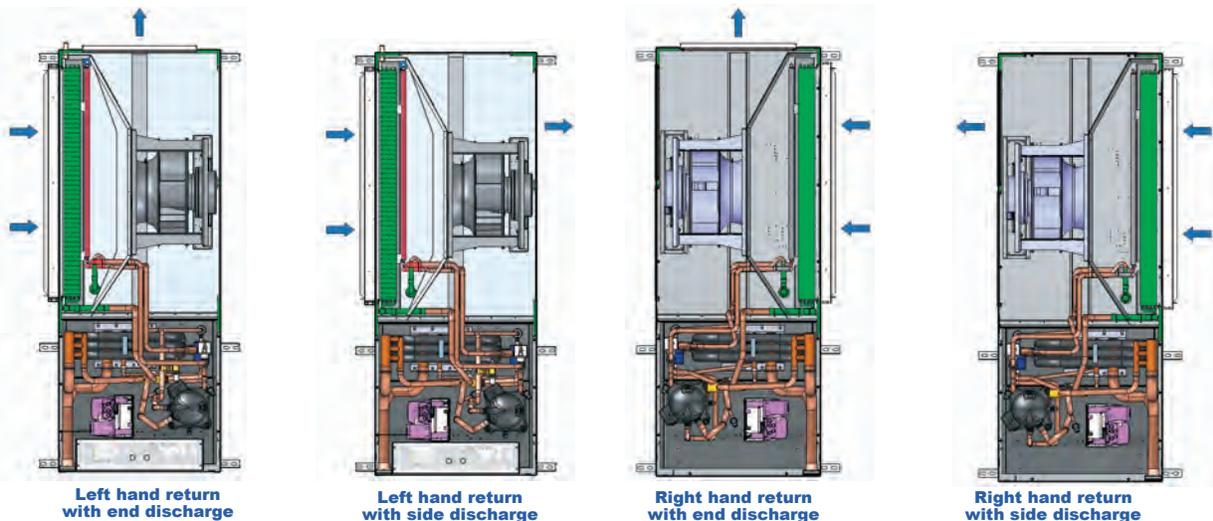

The YDL Series cont.

Product Features: Vertical Take-Apart



The YDL Series cont.

Aurora Controls

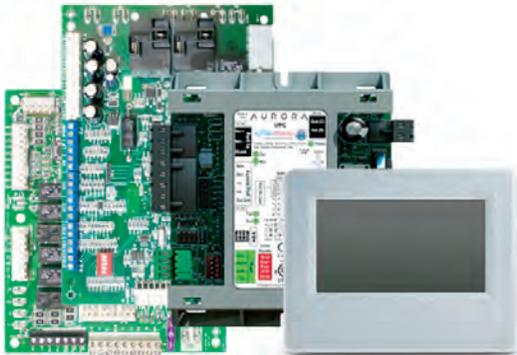

The Aurora Control System is a complete commercial comfort system that can bring all aspects of the HVAC system into one cohesive module network.

The Aurora Advanced and Premium Controls

provides all of the Aurora Base Control features plus it adds the extended I/O of the Aurora Expansion Board (AXB) to the mix. This extended I/O includes the energy monitoring as a standard feature where current transducers

measure current and power of fan and compressor. Aurora Premium Controls package is available to report refrigerant temperatures and pressures and will calculate superheat and subcooling and includes performance kit for measuring entering and leaving water temperatures along with source water flow rate via optional field installed flow meter



Quiet Operation

All models incorporates several noise reduction technologies and is ARI 260 sound rated using third party sound testing. Room Noise Criteria Curves (NC Curve) may be calculated using data from the ARI 260 ratings giving the engineer total flexibility in assuring a quiet environment. Please refer to the separate Sound Ratings and Performance Catalog concerning this standard and variable speed sound performance data.

Super Quiet Option

An optional Super Quiet Sound Package is also available for a modest cost and features multi-density laminate lined compressor blanket designed to completely surround the compressor and suppress low frequency noise.



Indoor Air Quality (IAQ)

All XL Series features several IAQ benefits:

- Corrosion-free stainless steel drain pan to eliminate standing water and prevent bacterial growth
- A washable surface on insulation in all air handler compartments to allow cleanability and inhibit bacteria growth. Optional non-fibrous closed cell insulation is also available for more sensitive applications.
- Factory mounted, four sided, [2.54 to 5.1 cm] deluxe filter rack is available for ducted return applications.

The YDL Series cont.

Internally Mounted Solenoid Valve Option

When variable speed circulating pump systems are designed, low pressure drop (high Cv) solenoid valves are specified at each unit to vary the pump according to flow required. It is important that these valves be low pressure drop to avoid unwanted pump watts. This option factory installs this valve inside the unit.

Secondary Drain Connection Option (Special Request)

Some local building authority's interpretation of codes require more condensate overflow protection than standard microprocessor based condensate sensors offer. In these areas a full secondary drain pan might be required causing both increased cost and unit service access issues. In many of these cases a secondary drain connection option can be added to the unit to pass this local interpretation of condensate drain redundancy. This option adds a second drain connection to the drain pan at a higher level.



Hot Gas Bypass

The hot gas bypass option is designed to limit the minimum evaporating pressure in the cooling mode to prevent the air coil from icing.

Electrical Disconnect

An optional factory mounted, internally wired disconnect is available to avoid scheduling problems with the electrical contractor. Other features include:

- Non-fused 'dial' type switch with "on/off" position
- Compact design
- "Lockout/Tagout" feature to keep the unit "off" during service



Factory Quality

- All refrigerant brazing is performed in a nitrogen environment.
- Computer controlled deep vacuum and refrigerant charging system.
- All joints are leak detected for maximum leak rate of less than 1/4 oz. per year.
- Computer bar code equipped assembly line ensures all components are correct.
- All units are computer run-tested with water to verify both function and performance.



Inside The YDL Series

Cabinet

All units are constructed of corrosion resistant galvanized sheet metal with optional white polyester powder coat paint rated for more than 1,000 hours of salt spray. Multiple lift-out access panel provides access to the compressor and air handler section to allow servicing of blower motor, blower, and drain pan. Refrigerant circuit is designed to allow primary serviceability from the front. Two (2) horizontal and four (4) vertical cabinets are provided for application flexibility. The blower motor and blower can be completely serviced or replaced without removal of the unit.

Flexible configurations include two (2) blower discharge options for horizontals and a true left and right return on both horizontal and vertical.

Filter Rack

All units come standard with a deluxe filter rack/duct collar for use with ducted returns.



Electrical Box

Unit controls feature quick connect wiring harnesses for easy servicing. Separate knockouts for low voltage and two sides of the electrical corner post for easy access to the control box. Large transformer 75VA assures adequate controls power for accessories.



Water Connections

Flush mount FPT water connection fittings allow one wrench leak-free connections and do not require a backup wrench.



Drain Pan

All condensate connections are stainless steel corrosion free connections. Complete drainage helps to inhibit bacterial or microbial growth. Vertical (top discharge) units feature an internally trapped condensate line using clear PVC hose for easy inspection and reduced installation cost.



Inside The YDL Series cont.

Scroll Compressors

These units use high efficiency dual capacity scroll compressors (7-10 ton) and single stage scroll compressors (12-30 ton). The compressors are hermetically sealed and mounted on rubber grommets for vibration isolation.



Air Handler Insulation

Washable air handler insulation surface provides cleanability to further enhance IAQ.



Optional Electronic Expansion Valve

A balanced port bidirectional electronic expansion valve (EEV) for refrigerant metering. This allows precise refrigerant flow in a wide range of entering water variation and compressor capacities (20 to 120°F [-7 to 49°C]). The EEV is located in the compressor compartment for easy access.



Water-to-Refrigerant Coaxial Heat Exchanger Coil

Large oversized coaxial refrigerant to water heat exchangers provide unparalleled efficiency. The coaxes are designed for low pressure drop and low flow rates. All coaxes are pressure rated to 450 psi water side and 600 psi on the refrigerant side. Optional ThermaShield coating is available on the water-to-refrigerant heat exchanger to prevent condensation in low temperature loop operation.



Service Connections and Serviceability

Two Schrader service ports are provided in every unit. The suction side and discharge side ports are for field charging and servicing access. All valves are 7/16 in. SAE connections. All water and electrical connections are made from the front of the unit. Unit is designed for front access serviceability.



4-Way Reversing Valve

All units feature a reliable all-brass pilot operated refrigerant reversing valve. The reversing valve operation is limited to change of mode by the control to enhance reliability.



All-Aluminum Air Coil

All aluminum air coils (7-10 ton) are constructed of all-aluminum round tube and high efficiency lanced fin design. All aluminum interlaced air coils (12-30 ton) are constructed for interlaced dual compressor circuit operation using high efficiency lanced fin design with all aluminum construction. Interlacing the coil circuits allows part load airflow operation and higher efficiencies.



Plenum Fan Motor and Blower

An integrated communicating variable speed EC fan motor with backward curve impeller (EC plenum fan) provides efficient airflow through 2" of external static and reduced cabinet footprint. The variable speed EC plenum fan provides softstart and high efficiency capability and utilizes easy airflow setup in the Aurora AID or Aurora Touch service tool.



Inside The YDL Series cont.

Advanced Service Features

- Aurora Controls with the AID Tool provide advanced service diagnostics. With this device setup and configurations as well as real-time sensors, fault and lockout history can be monitored and much more. This device is required for setup and troubleshooting of the unit.
- Features refrigeration service sensors as a standard feature. Now superheat, subcooling, refrigerant pressures and various temperatures needed to diagnose unit problems are readily available at your finger tips in the AID Tool right out of the box.
- Energy Monitoring - With this standard sensor kit installation, the Aurora Control will feature power monitoring of the compressor, blower, and electric heat. The information can be displayed on AID Tool, selected thermostats
- Advanced communication to the VS drive with faults, electrical, and operational information for quick diagnosis.

Communicating Digital Thermostats

- *Monochromatic Graphic Display Thermostats:* For user interface with the Aurora system; these displays not only feature easy to use graphical interface but display alerts and faults in plain English. When Energy Monitoring is added, instantaneous usage is displayed on the thermostat itself.
- *Color Touch Screen Graphic Display Thermostats:* For user interface with the Aurora system; these displays not only feature easy to use graphical interface but display alerts and faults in plain English. When Energy Monitoring is added not only instantaneous usage is displayed but also weekly and annual consumptions are stored and graphed. Other features include full color implementation, user loaded background photos, and USB port for easy configuration and software updates.

Performance Monitoring Kit (Flow meter required)

- With this optional sensor kit installation, the Aurora controls can measure actual capacity and efficiency performance of the heat pump; the information can be displayed on the AID Tool.

AID Tool

- The Aurora Interface and Diagnostics (AID) Tool is a plug-in configuration and troubleshooting tool for the Aurora Control System.

Aurora Controls

Aurora Controls

The Aurora Control System is a complete commercial comfort system that can bring all aspects of the HVAC system into one cohesive module network. The Aurora System is available in Aurora Base Control, Aurora Advanced and Aurora Premium Control.

Control	General Description	Application	Display/Interface	Protocol
<p>Aurora Base Control</p> 	<p>The ABC microprocessor provides all the features necessary to operate today's standard WSHPs that utilize dual capacity compressors and variable speed ECM/5 speed ECM blower motors with hot gas reheat. This control can communicate to a handheld diagnostic tool to help the installing contractor or service technician with equipment setup and service. By utilizing Modbus RTU communication protocol, the ABC board can communicate with additional devices on the Aurora network</p>	<p>Used for residential and commercial applications that use single or dual capacity compressors with PSC, 5-speed ECM, or variable speed ECM blower motors. This base control can also communicate to the AID Tool to display faults, inputs/outputs, and software revision. Commercial features such as hot gas reheat, slow opening water valve, and random start are also capable with the ABC board.</p>	<p>Optional AID tool can be used for field service.</p>	<p>Standalone</p>
<p>Aurora Advanced and Premium</p> 	<p>Aurora Advanced Control adds the Aurora AXB expansion board and provides added I/O and standard features such as refrigerant, performance or energy monitoring.</p>	<ul style="list-style-type: none"> • Refrigeration Monitoring – provides Suction and discharge pressure, Suction, liquid line temps and superheat and subcooling. • Performance Monitoring – provides entering and leaving loop water temperatures, loop flow rate as well as heat of extraction or rejection rate into the loop. • Energy Monitoring – provides real-time power measurement (Watt) of compressor, fan, auxiliary heat and zone pump. • Plus many more I/O options 	<p>Optional AID tool can be used for field service.</p>	<p>Standalone</p>

Aurora Controls cont.

Aurora 'Base' Control



NOTE: Refer to the Aurora Base Control Application and Troubleshooting Guide and the Instruction Guide: Aurora Interface and Diagnostics (AID) Tool for additional information.

The Aurora Base Control provides all baseline operation of 7 faults (HP, LP and LOC, coax freeze protection, air coil Freeze protection, over/under Voltage and condensate overflow), as well as compressor and fan speed and lockout management through the single ABC board (Aurora Base Control). The control features all heat pump operational timings, configurations, sensors and fault history that can be viewed using then AID tool.

Control Features

Software ABC Standard Version 3.0

Single or Dual Capacity Compressors

Either single or dual capacity compressors can be operated.

Variable Speed ECM

Blower Motor Option (If Applicable)

A Variable Speed ECM blower motor can be driven directly using the onboard PWM output. Four blower speeds are available based upon the G, Y1, Y2, and W input signals to the board. The blower speeds can be changed either by the ECM manual configurations mode method or by using the Aurora AID Tool directly. All four blower speeds can be set to the same speed if desired.

5-Speed ECM Blower Motor Option (If Applicable)

A 5-Speed ECM blower motor will be driven directly using the thermostat connections. Any of the G, Y1, or Y2/W signals can drive any of the 5 available pre-programmed blower speeds on the motor.

Other Control Features

- Random start at power up
- Anti-short cycle protection
- High and low pressure cutouts
- Loss of charge
- Water coil freeze detection
- Air coil freeze detection
- Over/under voltage protection
- Condensate overflow sensor
- Load shed
- Dehumidification (where applicable)
- Emergency shutdown
- Hot gas reheat operation (where applicable)
- Diagnostic LED
- Test mode push button switch
- Two auxiliary electric heat outputs
- Alarm output
- Accessory output with N.O. and N.C.
- Modbus communication (master)
- Modbus communication (slave)

Aurora Controls cont.

Field Selectable Options via Hardware

DIP Switch (SW1) – Test/Configuration Button (See SW1 Operation Table)

Test Mode

The control is placed in the test mode by holding the push button switch SW1 for 2 - 5 seconds. In test mode most of the control timings will be shortened by a factor of sixteen (16). LED3 (green) will flash at 1 second on and 1 second off. Additionally, when entering test mode LED1 (red) will flash the last lockout one time. Test mode will automatically time out after 30 minutes. Test mode can be exited by pressing and holding the SW1 button for 2 to 5 seconds or by cycling the power. **NOTE:** Test mode will automatically be exited after 30 minutes.

Variable Speed ECM Configuration Mode (If Applicable)

The control is placed in the ECM configuration mode by holding the pushbutton switch SW1 for 5 to 10 seconds, the high, low, and “G” ECM speeds can be selected by following the LED display lights. LED2 (yellow) will fast flash when entering the ECM configuration. When setting “G” speed LED3 (green) will be continuously lit, for low speed LED1 (red) will be continuously lit, and for high speed both LED3 (green) and LED1 (red) will be continuously lit. During the ECM configuration mode LED2 (yellow) will flash each of the 12 possible blower speeds 3 times. When the desired speed is flashed press SW1, LED2 will fast flash until SW1 is released. “G” speed has now been selected. Next select low speed, and high speed blower selections following the same process above. After third selection has been made, the control will exit the ECM configuration mode. Aux fan speed will remain at default or current setting and requires the AID Tool for adjustment.

Reset Configuration Mode

The control is placed in reset configuration mode by holding the push button switch SW1 for 50 to 60 seconds. This will reset all configuration settings and the EEPROM back to the factory default settings. LED3 (green) will turn off when entering reset configuration mode. Once LED3 (green) turns off, release SW1 and the control will reset.

DIP Switch (SW2)

- SW2-1** FP1 Selection – Low water coil temperature limit setting for freeze detection. On = 30°F; Off = 15°F.
- SW2-2** FP2 Selection – On = 30°F; Off = N/A
- SW2-3** RV – O/B - thermostat type. Heat pump thermostats with “O” output in cooling or “B” output in Heating can be selected. On = O; Off = B.
- SW2-4** Access Relay Operation (P2)
and 2-5

Access Relay Operation	SW2-4	SW2-5
Cycle with Blower	ON	ON
Cycle with Compressor	OFF	OFF
Water Valve Slow Opening	ON	OFF
Cycle with Comm. T-stat Hum Cmd	OFF	ON

Cycle with Blower - The accessory relay will cycle with the blower output.

Cycle with Compressor - The accessory relay will cycle with the compressor output.

Water Valve Slow Opening - The accessory relay will cycle and delay both the blower and compressor output for 90 seconds.

- SW2-6** CC Operation – selection of single or dual capacity compressor. On = Single Stage; Off = Dual Capacity
- SW2-7** Lockout and Alarm Outputs (P2) – selection of a continuous or pulsed output for both the LO and ALM Outputs. On = Continuous; Off = Pulsed
- SW2-8** *Future Use*

Alarm Jumper Clip Selection

From the factory, ALM is connected to 24 VAC via JW2. By cutting JW2, ALM becomes a dry contact connected to ALG.

Variable Speed ECM Blower Speeds

The blower speeds can be changed either by using the ECM manual configurations mode method or by using the Aurora AID Tool directly (see Instruction Guide: Aurora Interface and Diagnostics (AID) Tool topic).

Aurora Controls cont.

Field Selectable Options via Software

(Selectable via the Aurora AID Tool)

ECM Blower Speeds

An ECM blower motor can be driven directly using the onboard PWM output. Four blower speeds are available, based upon the “G”, Y1 (low), Y2 (high), and Aux input signals to the board. The blower speeds can be changed either by the ECM manual configurations mode method (see ECM Configuration Mode topic) or by using the Aurora AID Tool directly. All four blower speeds can be set to the same speed if desired. Aux blower speed will remain at default or current setting and requires the AID Tool for adjustment.

Safety Features

The following safety features are provided to protect the compressor, heat exchangers, wiring and other components from damage caused by operation outside of design conditions.

Fuse - a 3 amp automotive type plug-in fuse provides protection against short circuit or overload conditions.

Anti-Short Cycle Protection - 4 minute anti-short cycle protection for the compressor.

Random Start - 5 to 80 second random start upon power up.

Fault Retry - in the fault condition, the control will stage off the outputs and then “try again” to satisfy the thermostat Y input call. Once the thermostat input calls are satisfied, the control will continue on as if no fault occurred. If 3 consecutive faults occur without satisfying the thermostat Y input call, then the control will go to Lockout mode.

Lockout - when locked out, the blower will operate continuously in “G” speed, and PSC blower motor output will remain on. The Alarm output (ALM) and Lockout output (L) will be turned on. The fault type identification display LED1 (Red) shall flash the fault code. To reset lockout conditions with SW2-8 On, thermostat inputs “Y1”, “Y2”, and “W” must be removed for at least 3 seconds. To reset lockout conditions with SW2-8 Off, thermostat inputs “Y1”, “Y2”, “W”, and “DH” must be removed for at least 3 seconds. Lockout may also be reset by turning power off for at least 30 seconds or by enabling the emergency shutdown input for at least 3 seconds.

Lockout With Emergency Heat - if the control is locked out in the heating mode, and a Y2 or W input is received, the control will operate in the emergency heat mode while the compressor is locked out. The first emergency heat output will be energized 10 seconds after the W input is received, and the blower will shift to high speed. If the control remains locked out, and the W input is present, additional stage of emergency heat will stage on after 2 minutes. When the W input is

removed, all of the emergency heat outputs will turn off, and the ECM blower will shift to “G” speed and PSC blower motor output will remain on.

High Pressure - fault is recognized when the Normally Closed High Pressure Switch, P4-9/10 opens, no matter how momentarily. The High Pressure Switch is electrically in series with the Compressor Contactor and serves as a hard-wired limit switch if an overpressure condition should occur.

Low Pressure - fault is recognized when the Normally Closed Low Pressure Switch, P4-7/8 is continuously open for 30 seconds. Closure of the LPS any time during the 30 second recognition time restarts the 30 second continuous open requirement. A continuously open LPS shall not be recognized during the 2 minute startup bypass time.

Loss of Charge - fault is recognized when the Normally Closed Low Pressure Switch, P4-7/8 is open prior to the compressor starting.

Condensate Overflow - fault is recognized when the impedance between this line and 24 VAC common or chassis ground drops below 100K ohms for 30 seconds continuously.

Freeze Detection (Coax) - set points shall be either 30°F or 15°F. When the thermistor temperature drops below the selected set point, the control shall begin counting down the 30 seconds delay. If the thermistor value rises above the selected set point, then the count should reset. The resistance value must remain below the selected set point for the entire length of the appropriate delay to be recognized as a fault. This fault will be ignored for the initial 2 minutes of the compressor run time.

Freeze Detection (Air Coil) - uses the FP2 input to protect against ice formation on the air coil. The FP2 input will operate exactly like FP1 except that the set point is 30 degrees and is not field adjustable.

Over/Under Voltage Shutdown - An over/under voltage condition exists when the control voltage is outside the range of 18 VAC to 30 VAC. If the over/under voltage shutdown lasts for 15 minutes, the lockout and alarm relay will be energized. Over/under voltage shutdown is self-resetting in that if the voltage comes back within range of 18 VAC to 30 VAC for at least 0.5 seconds, then normal operation is restored.

Aurora Controls cont.

Operation Description

Power Up - The unit will not operate until all the inputs and safety controls are checked for normal conditions. The unit has a 5 to 80 second random start delay at power up. Then the compressor has a 4 minute anti-short cycle delay after the random start delay.

Standby In standby mode, Y1, Y2, W, DH, and G are not active. Input O may be active. The blower and compressor will be off.

Heating Operation

Single Compressor Heating, 2nd Stage (Y1, Y2)

The compressor will be staged to full capacity 20 seconds after Y2 input is received. The ECM blower will shift to high speed seconds after the Y2 input is received.

Dual Compressor Heating, 2nd Stage (Y1, Y2)

In dual compressor operation, two ABC boards used in 24 VAC operation, there will be a Y2 call to the Y1 input on the second ABC. The compressor will stage to full capacity 30 seconds after Y1 input is received to the second board.

Single Compressor Heating, 3rd Stage (Y1, Y2, W)

The hot water pump is de-energized and the first stage of electric heat is energized 10 seconds after the W command is received. If the demand continues the second stage of electric heat will be energized after 5 minutes.

Dual Compressor Heating, 3rd Stage (Y1, Y2, W) -

The first stage of electric heat is energized 10 seconds after the W command is received. If the demand continues the second stage of electric heat will be energized after 5 minutes

Emergency Heat (W) - The blower will be started on "G" speed, 10 seconds later the first stage of electric heat will be turned on. 5 seconds after the first stage of electric heat is energized the blower will shift to Aux speed. If the emergency heat demand is not satisfied after 2 minutes the second electric heat stage will be energized.

Blower (G) - The blower will start immediately upon receiving a thermostat G command. If there are no other commands from the thermostat the ECM will run on "G" speed until the G command is removed. Regardless of blower input (G) from the thermostat, the blower will remain on for 30 seconds at the end of each heating cycle.

Cooling Operation

In all cooling operations, the reversing valve directly tracks the O input. Thus, anytime the O input is present, the reversing valve will be energized.

Single Compressor Cooling, 2nd Stage (Y1, Y2, O)

The compressor will be staged to full capacity 20 seconds after Y2 input was received. The ECM blower will shift to high speed 15 seconds after the Y2 input was received.

Dual Compressor Cooling, 2nd Stage (Y1, Y2, O)

In dual compressor operation, two ABC boards used in 24 VAC operation, there will be a Y2 call to the Y1 input on the second ABC. The compressor will stage to full capacity 30 seconds after Y1 input is received to the second board.

Blower (G) - The blower will start immediately upon receiving a thermostat G command. If there are no other commands from the thermostat the ECM will run on "G" speed until the G command is removed. Regardless of blower input (G) from the thermostat, the blower will remain on for 30 seconds at the end of each heating, cooling, and emergency heat cycle.

Dehumidification (Y1, O, DH or Y1, Y2, O, DH) - When a DH command is received from the thermostat during a compressor call for cooling the ECM blower speed will be reduced by 15% to increase dehumidification.

Emergency Shutdown - Four (4) seconds after a valid ES input, P2-7 is present, all control outputs will be turned off and remain off until the emergency shutdown input is no longer present. The first time that the compressor is started after the control exits the emergency shutdown mode, there will be an anti-short cycle delay followed by a random start delay. Input must be tied to common to activate.

Continuous Blower Operation - The blower output will be energized any time the control has a G input present, unless the control has an emergency shutdown input present. The blower output will be turned off when G input is removed.

Load Shed - The LS input disables all outputs with the exception of the blower output. When the LS input has been cleared, the anti-short cycle timer and random start timer will be initiated. Input must be tied to common to activate.

Aurora Controls cont.

Aurora ‘Base’ Control LED Displays

These three LEDs display the status, configuration, and fault codes for the control. These can also be read in plain English via the Aurora AID Tool.

Status LED (LED3, Green)

Description of Operation	Fault LED, Green
Normal Mode	ON
Control is Non-functional	OFF
Test Mode	Slow Flash
Lockout Active	Fast Flash
Dehumidification Mode	Flash Code 2
(Future Use)	Flash Code 3
(Future Use)	Flash Code 4
Load Shed	Flash Code 5
ESD	Flash Code 6
(Future Use)	Flash Code 7

Configuration LED (LED2, Yellow)

Description of Operation	Configuration LED, Yellow
No Software Overwritten	Flashing ECM Setting
DIP Switch was Overwritten	Slow Flash
ECM Configuration Mode	Fast Flash

Fault LED (LED1, Red)

Red Fault LED		LED Flash Code*	Lockout	Reset/Remove
ABC Basic Faults	Normal - No Faults	OFF	-	
	Fault - Input	1	No	Auto
	Fault - High Pressure	2	Yes	Hard or Soft
	Fault - Low Pressure	3	Yes	Hard or Soft
	Fault - Freeze Detection FP2	4	Yes	Hard or Soft
	Fault - Freeze Detection FP1	5	Yes	Hard or Soft
	Fault - Condensate Overflow	7	Yes	Hard or Soft
	Fault - Over/Under Voltage	8	No	Auto
	Fault - FP1 & FP2 Sensor Error	11	Yes	Hard or Soft

NOTE: All codes >11 use long flash for tens digit and short flash for the ones digit. 20, 30, 40, 50, etc. are skipped.

Aurora Interface and Diagnostics (AID) Tool

The Aurora Interface and Diagnostics (AID) Tool is a device that is a member of the Aurora network. The AID Tool is used to troubleshoot equipment which uses the Aurora control via Modbus RTU communication. The AID Tool provides diagnostics, fault management, ECM setup, and system configuration capabilities to the Aurora family of controls. An AID Tool is recommended, although not required, for ECM airflow settings. The AID Tool simply plugs into the ABC-A board.



ABC Control Board Layout

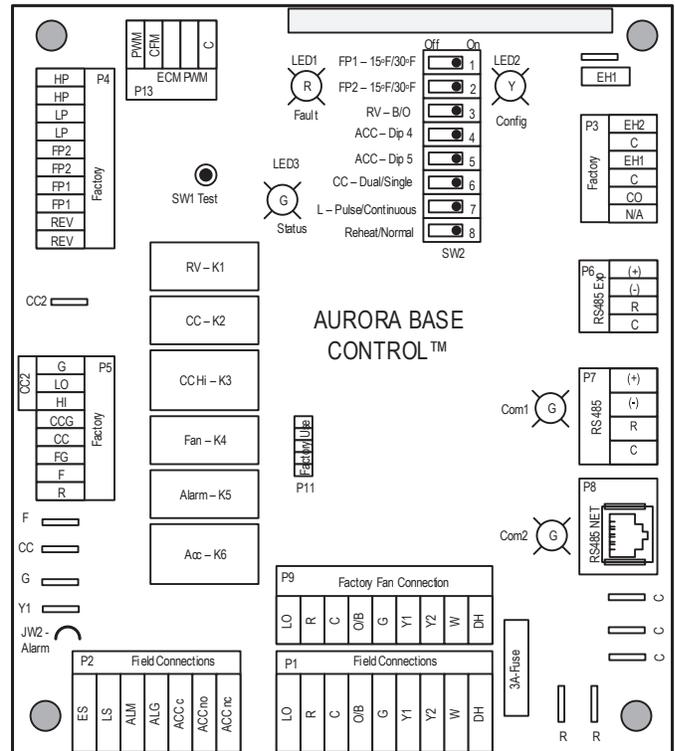

Aurora Controls cont.

Aurora Advanced and Aurora Premium Controls



The **Aurora Advanced and Aurora Premium Control** provides all of the Aurora Base Control features plus it adds the extended I/O of the Aurora Expansion Board (AXB) to the mix. This extended I/O includes the energy monitoring where current transducers measure current and power of fan and compressor. Aurora Premium Controls add refrigeration monitoring kit that reports refrigerant temperatures and pressures and will calculate superheat and subcooling. The Premium package also includes performance kit for entering and leaving water temperature along with source water flow rate via optional field installed flow meter.

Aurora Advanced And Aurora Premium Control Features

The Aurora 'Advanced' Control system expands on the capability of the Aurora 'Base' Control (ABC) by adding the Aurora Expansion Board (AXB). All of the preceding features of the Aurora 'Base' Control are included. The following control description is of the additional features and capability of the Aurora advanced control.

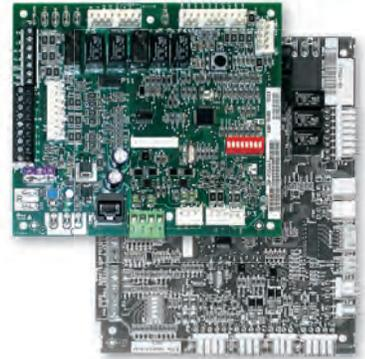

It is highly recommended the installing/servicing contractor obtain an Aurora Interface and Diagnostic Tool (AID) and specialized training before attempting to install or service an Aurora 'Advanced' control system.



The additional AXB features include the following:

Leaving Air Temperature Sensor

Standard on all Aurora Advanced Controls is a leaving air (discharge air) sensor. This sensor is pre-mounted for downflow applications and will need to be repositioned for side discharge applications in a high velocity location for best results

AXB DIP Switch

DIP 1 - ID: This is the AXB ModBus ID and should always read On.

DIP 2 & 3 - Future Use

DIP 4 & 5 - Accessory Relay2: A second, DIP configurable, accessory relay is provided that can be cycled with the compressor 1 or 2 , blower, or the Dehumidifier (DH) input. This is to complement the Accessory 1 Relay on the ABC board.

Position	DIP 4	DIP 5	Description
1	ON	ON	Cycles with Fan or ECM (or G)
2	OFF	ON	Cycles with CC1 first stage of compressor or compressor spd 1-6
3	ON	OFF	Cycles with CC2 second stage of compressor or compressor spd 7-12
4	OFF	OFF	Cycles with DH input from ABC board

Compressor Monitoring

The AXB includes two current transducers to monitor the compressor current and starting characteristics. Open circuits or welded contactor faults will be detected. This fault will produce an E10 code.

Aurora Controls cont.

Aurora ‘Advanced’ Control LED Displays

These three LEDs display the status, configuration, and fault codes for the control. These can also be read in plain English via the Aurora AID Tool.

Status LED (LED3, Green)

Description of Operation	Fault LED, Green
Normal Mode	ON
Control is Non-functional	OFF
Test Mode	Slow Flash
Lockout Active	Fast Flash
Dehumidification Mode	Flash Code 2
Load Shed	Flash Code 5
Emergency Shutdown	Flash Code 6
On Peak Mode	Flash Code 7
(Future Use)	Flash Code 8
(Future Use)	Flash Code 9

Configuration LED (LED2, Yellow)

Description of Operation	Configuration LED, Yellow
No Software Overwritten	ECM Setting
DIP Switch Overwritten	Slow Flash
ECM Configuration Mode	Fast Flash
Reset Configuration Mode	OFF

Fault LED (LED1, Red)

Red Fault LED		LED Flash Code *	Lockout	Reset/ Remove	Fault Condition Summary
ABC Basic Faults	Normal - No Faults	Off	-		
	Fault-Input	1	No	Auto	Tstat input error. Autoreset upon condition removal.
	Fault-High Pressure	2	Yes	Hard or Soft	HP switch has tripped (>600 psi)
	Fault-Low Pressure	3	Yes	Hard or Soft	Low Pressure Switch has tripped (<40 psi for 30 continuous sec.)
	Fault-Freeze Detection FP2	4	Yes	Hard or Soft	Freeze protection sensor has tripped (<15 or 30 degF for 30 continuous sec.)
	Fault-Freeze Detection FP1	5	Yes	Hard or Soft	Freeze protection sensor has tripped (<15 or 30 degF for 30 continuous sec.)
	Fault-Condensate Overflow	7	Yes	Hard or Soft	Condensate switch has shown continuity for 30 continuous sec.
ABC & AXB Advanced Faults	Fault-Over/Under Voltage	8	No	Auto	Instantaneous voltage is out of range. **Controls shut down until resolved.
	Fault-FP1 Sensor Error	11	Yes	Hard or Soft	FP1 Sensor Open or Shorted
	Fault-Compressor Monitor	10	Yes	Hard or Soft	Open Crkt, Run, Start or welded cont
	Non-CriticAXB SnsrErr	13	No	Auto	Any Other Sensor Error
	CriticAXB SnsrErr	14	Yes	Hard or Soft	Sensor Error for EEV or HW
	Alert-HotWtr	15	No	Auto	HW over limit or logic lockout. HW pump deactivated.
	Fault-VarSpdPump	16	No	Auto	Alert is read from PWM feedback.
	Non-CritComErr	18	No	Auto	Any non-critical com error
	Fault-CritComErr	19	No	Auto	Any critical com error. Auto reset upon condition removal
	Alarm - Low Loop Pressure	21	No	Auto	Loop pressure is below 3 psi for more than 3 minutes
Alarm - Home Automation 1	23	No	Auto	Closed contact input is present on Dig 2 input - Text is configurable	
Alarm - Home Automation 2	24	No	Auto	Closed contact input is present on Dig 3 input - Text is configurable	

NOTES: *All codes >11 use long flash for tens digit and short flash for the ones digit. 20, 30, 40, 50 etc. are skipped!
Alert' is a noncritical sensor or function that has failed. Normal operation of the heat pump is maintained but service is desired at some point.

Operation Logic Data Table

Operation Logic Table	Heating					Cooling			
	STG1	STG2	STG3	EMERG	Fan Only	STG1	STG2	Reheat	Fan Only
Compressor	On	On	On	Off	Off	On	On	On	Off
Reversing Valve	Off	Off	Off	Off	Off	On	On	On	On
Aux Heat	Off	Off	Staged	Staged	Off	Off	Off	Off	Off
Acc Relay	On	On	On	Off	Off	On	On	On	Off
Fan Relay (PSC)	On	On	On	On	On	On	On	On	On
Loop Pump	On	On	On	Off	Off	On	On	On	Off
Hot Water	On	On	Off	Off	Off	On	On	NA	Off
5-Speed ECM Speed	Med Low	Med High	High	High	Low	Med Low	Med High	High	Low
ECM Speed	Med	High	Aux	Aux	Low	Med	High	High	Low
T-Stat Signal	Y1	Y1,Y2	Y1,Y2,W	W	G	Y1,O	Y1,Y2,O	DH	G

Application Notes

The Closed Loop Heat Pump Concept

The basic principle of a water source heat pump is the transfer of heat into water from the space during cooling, or the transfer of heat from water into the space during heating. Extremely high levels of energy efficiency are achieved as electricity is used only to move heat, not to produce it. Using a typical large water-to-air unit, one unit of electricity will move four to five units of heat.

When multiple water source heat pumps are combined on a common circulating loop, the ultimate in energy efficiency is created: The units on cooling mode are adding heat to the loop which the units in heating mode can absorb, thus removing heat from the area where cooling is needed, recovering and redistributing that heat for possible utilization elsewhere in the system. In modern commercial structures, this characteristic of heat recovery from core area heat generated by lighting, office equipment, computers, solar radiation, people or other sources, is an important factor in the high efficiency and low operating costs of closed source heat pump systems.

In the event that a building's net heating and cooling

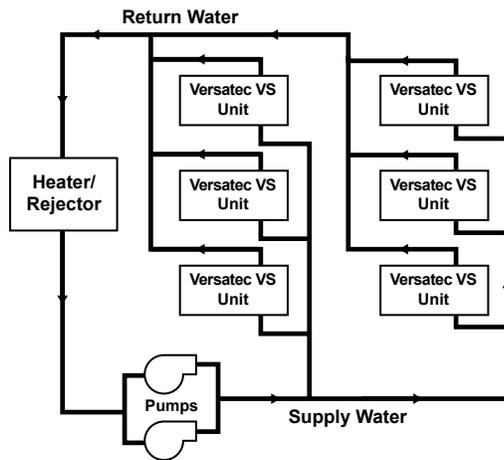

requirements create loop temperature extremes, large water-to-air units have the extended range capacity and versatility to maintain a comfortable environment for all building areas. Excess heat can be stored for later utilization or be added or removed in one of three ways; by ground-source heat exchanger loops: plate heat exchangers connected to other water sources, or conventional cooler/boiler configurations. Your representative has the expertise and computer software to assist in determining optimum system type for specific applications.

The Closed Loop Advantage

A properly applied water source heat pump system offers many advantages over other systems. First costs are low because units can be added to the loop on an "as needed basis"- perfect for speculative buildings. Installed costs are low since units are self-contained and can be located adjacent to the occupied space, requiring minimal ductwork. Maintenance can be done on individual units without system shut-down. Conditions remain comfortable since each unit operates separately, allowing cooling in one area and heating in another. Tenant spaces can be finished and added as needed. Power billing to tenants is also convenient since each unit can be individually metered: each pays for what each uses. Nighttime and/or weekend uses of certain areas are possible without heating or cooling the entire facility. A decentralized system also means if one unit should fault, the rest of the system will continue to operate normally, as well as eliminating air cross-contamination problems and expensive high pressure duct systems requiring an inefficient electric resistance reheat mode.

The Large Water-to-Air Approach

There are a number of proven choices in the type of large water-to-air systems which would be best for any given application. Most often considered are:

Vertical - Closed Loop/Ground Source



- **Closed Loop/Ground-Source Systems** utilize the stable temperatures of the earth to maintain proper water source temperatures (via vertical or horizontal closed loop heat exchangers) for large water-to-air units extended range heat pump system. Sizes range from a single unit through many hundreds of units. When net cooling requirements cause closed loop water temperatures to

Application Notes cont.

rise, heat is dissipated into the cooler earth through buried high strength plastic pipe “heat exchangers.” Conversely if net space heating demands cause loop heat absorption beyond that heat recovered from building core areas, the loop temperature will fall causing heat to be extracted from the earth. Due to the extended loop temperatures, AHRI/ISO 13256-1 Ground Loop Heat Pumps are required for this application. Because auxiliary equipment such as a fossil fuel boiler and cooling tower are not required to maintain the loop temperature, operating and maintenance costs are very low.

Ground-source systems are most applicable in residential and light commercial buildings where both heating and cooling are desired, and on larger envelope dominated structures where core heat recovery will not meet overall heating loads. Both vertical and horizontally installed closed-loops can be used. The land space required for the “heat exchangers” is 100-250 sq. ft./ton on vertical (drilled) installations and 750-1500 sq. ft./ton for horizontal (trenched) installations. Closed loop heat exchangers can be located under parking areas or even under the building itself.

On large multi-unit systems, sizing the closed loop heat exchanger to meet only the net heating loads and assisting cooling loads with a closed circuit cooling tower may be the most cost effective choice.

Surface Water - Closed Loop/Ground Source



• **Closed Loop/Ground-Source Surface Water Systems** also utilize the stable temperatures of Surface Water to maintain proper water source temperatures for large water-to-air units extended range heat pump systems. These systems have all of the advantages of horizontal and vertical closed loop systems. Due to the extended loop temperatures, AHRI/ISO 13256-1 Ground Water or Ground Loop Heat Pumps are required for this application.

In cooling dominated structures, the ground-source surface water systems can be very cost effective especially where local building codes require water retention ponds for short term storage of surface run-off. Sizing requirements for the surface water is a minimum of 500 sq. ft./ton of surface area at a minimum depth of 8 feet. The manufacturer should be contacted when designs for heating dominated structures are required.

Plate Heat Exchanger - Closed Loop/Ground Water

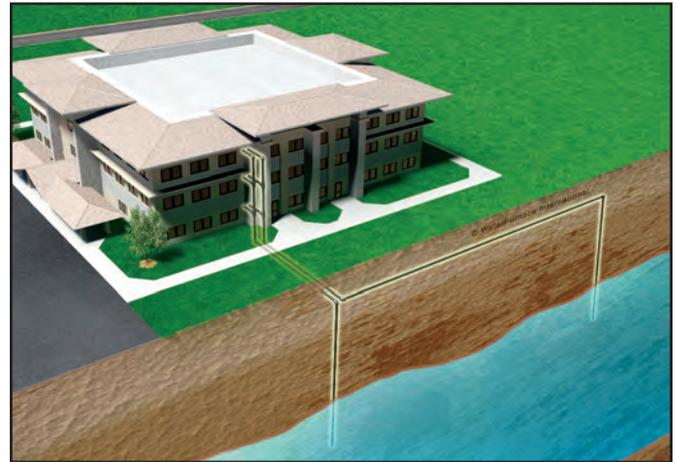

• **Closed Loop/Ground Water Plate Heat Exchanger Systems** utilize lake, ocean, well water or other water sources to maintain closed loop water temperatures in multi-unit large water-to-air systems. A plate frame heat exchanger isolates the units from any contaminating effects of the water source, and allows periodic cleaning of the heat exchanger during off peak hours.

Operation and benefits are similar to those for ground-source systems. Due to the extended loop temperatures, AHRI/ISO 13256-1 Ground Loop Heat Pumps are required for this application. Closed loop plate heat exchanger systems are applicable in commercial, marine, or industrial structures where the many benefits of a water source heat pump system are desired, regardless of whether the load is heating or cooling dominated.

Application Notes cont.

Cooler/Boiler - Closed Loop



• **Closed Loop /Cooler-Boiler Systems** utilize a closed heat recovering loop with multiple water source heat pumps in the more conventional manner. Typically a boiler is employed to maintain closed loop temperatures above 60°F and a cooling tower to maintain loop temperatures below 90°F. These systems are applicable in medium to large buildings regardless of whether the load is heating or cooling dominated. Due to the moderate loop temperatures, AHRI/ISO 13256-1 Water Loop Heat Pumps are required for this application.

Water Quality

In ground water situations where scaling could be heavy or where biological growth such as iron bacteria will be present, a closed loop system is recommended. The heat exchanger coils in ground water systems may, over a period of time, lose heat exchange capabilities due to a buildup of mineral deposits inside. These can be cleaned, but only by a qualified service mechanic, as special solutions and pumping equipment are required. Hot water generator coils can likewise become scaled and possibly plugged. In areas

with extremely hard water, the owner should be informed that the heat exchanger may require occasional flushing. Failure to adhere to the guidelines in the water quality table could result in loss of warranty.

Units with cupronickel heat exchangers are recommended for open loop applications due to the increased resistance to build-up and corrosion, along with reduced wear caused by acid cleaning.

Material		Copper	90/10 Cupronickel	316 Stainless Steel
pH	Acidity/Alkalinity	7 - 9	7 - 9	7 - 9
Scaling	Calcium and Magnesium Carbonate	(Total Hardness) less than 350 ppm	(Total Hardness) less than 350 ppm	(Total Hardness) less than 350 ppm
Corrosion	Hydrogen Sulfide	Less than 0.5 ppm (rotten egg smell appears at 0.5 ppm)	10 - 50 ppm	Less than 1 ppm
	Sulfates	Less than 125 ppm	Less than 125 ppm	Less than 200 ppm
	Chlorine	Less than 0.5 ppm	Less than 0.5 ppm	Less than 0.5 ppm
	Chlorides	Less than 20 ppm	Less than 125 ppm	Less than 300 ppm
	Carbon Dioxide	Less than 50 ppm	10 - 50 ppm	10 - 50 ppm
	Ammonia	Less than 2 ppm	Less than 2 ppm	Less than 20 ppm
	Ammonia Chloride	Less than 0.5 ppm	Less than 0.5 ppm	Less than 0.5 ppm
	Ammonia Nitrate	Less than 0.5 ppm	Less than 0.5 ppm	Less than 0.5 ppm
	Ammonia Hydroxide	Less than 0.5 ppm	Less than 0.5 ppm	Less than 0.5 ppm
	Ammonia Sulfate	Less than 0.5 ppm	Less than 0.5 ppm	Less than 0.5 ppm
	Total Dissolved Solids (TDS)	Less than 1000 ppm	1000 - 1500 ppm	1000 - 1500 ppm
	LSI Index	+0.5 to -0.5	+0.5 to -0.5	+0.5 to -0.5
Iron Fouling (Biological Growth)	Iron, FE ²⁺ (Ferrous) Bacterial Iron Potential	< 0.2 ppm	< 0.2 ppm	< 0.2 ppm
	Iron Oxide	Less than 1 ppm, above this level deposition will occur	Less than 1 ppm, above this level deposition will occur	Less than 1 ppm, above this level deposition will occur
Erosion	Suspended Solids	Less than 10 ppm and filtered for max. of 600 micron size	Less than 10 ppm and filtered for max. of 600 micron size	Less than 10 ppm and filtered for max. of 600 micron size
	Threshold Velocity (Fresh Water)	< 6 ft/sec	< 6 ft/sec	< 6 ft/sec

NOTES: Grains = ppm divided by 17
mg/L is equivalent to ppm

2/22/12

Installation Notes

Typical Unit Installation

Unit Location

Locate the unit in an indoor area that allows for easy removal of the filter and access panels. Location should have enough space for service personnel to perform maintenance or repair. Provide sufficient room to make water, electrical and duct connection(s). If the unit is located in a confined space, such as a closet, provisions must be made for return air to freely enter the space by means of a louvered door, etc. Any access panel screws that would be difficult to remove after the unit is installed should be removed prior to setting the unit. On horizontal units, allow adequate room below the unit for a condensate drain trap and do not locate the unit above supply piping. Care should be taken when units are located in unconditioned spaces to prevent damage from frozen water lines and excessive heat that could damage electrical components.

Water Piping

Piping is usually design as 'reverse return' to equalize flow paths through each unit. A short flexible pressure rated hose is used to make connection to the fixed building

piping system. This hose is typically stainless steel braid and includes a swivel fitting on one end for easy removal and is flexible to help isolate the unit for quieter operation. Isolation valves for servicing, y-strainers for filtering and memory-stop flow valve or a balancing valve can be provided for consistent water flow through the unit.

All unit source water connections are fittings that accept a male pipe thread (MPT). Insert the connectors by hand, then tighten the fitting with a wrench to provide a leakproof joint. The open and closed loop piping system should include pressure/temperature ports for serviceability. The proper water flow must be provided to each unit whenever the unit operates. To assure proper flow, use pressure/temperature ports to determine the flow rate. These ports should be located at the supply and return water connections on the unit. The proper flow rate cannot be accurately set without measuring the water pressure drop through the refrigerant-to-water heat exchanger. Never use flexible hoses smaller than the inside diameter of the water connection at the unit. Limit hose length to 10 feet per connection. Check carefully for water leaks.

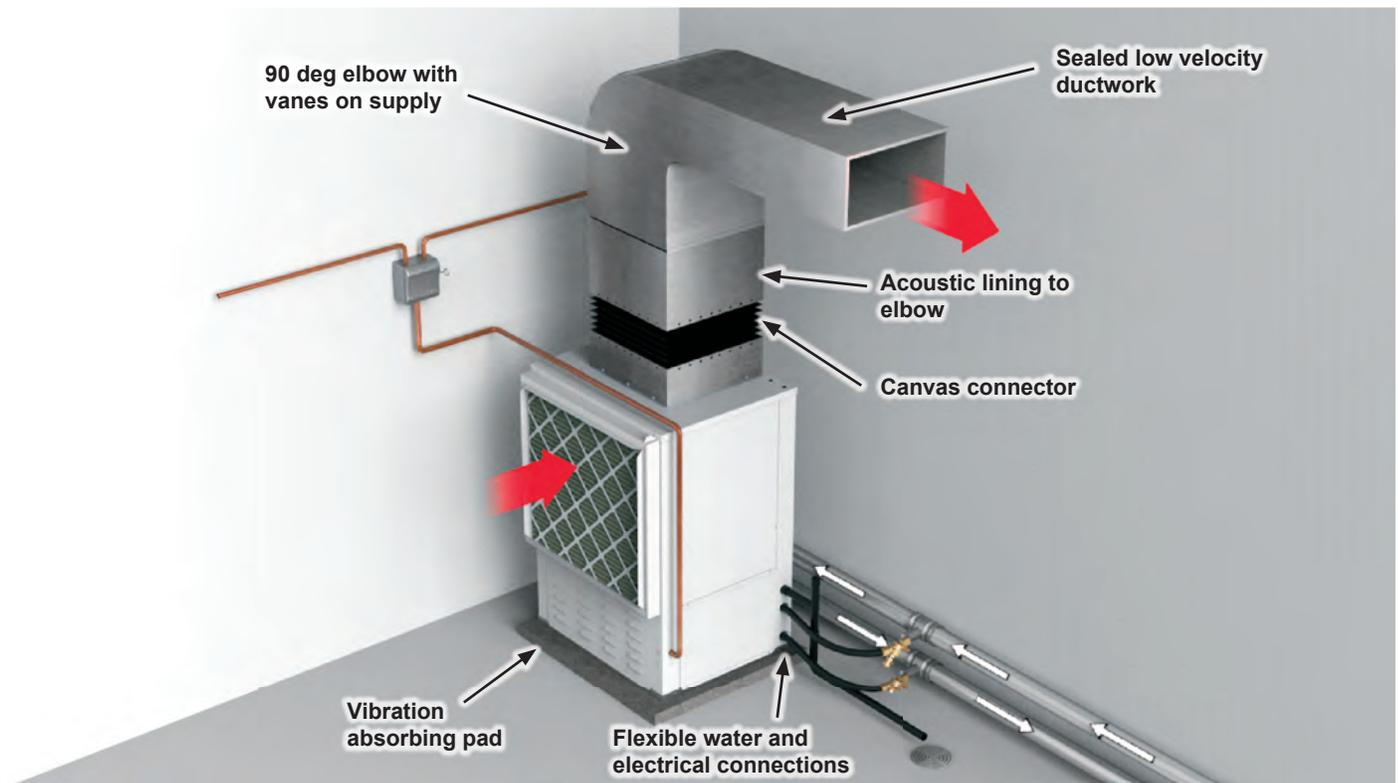

Installation Notes cont.

Installing Horizontal Units

Remove and discard the compressor hold down shipping bolt located at the front of the compressor mounting bracket prior to setting the unit in place. Horizontal units are available with side or end discharge.

NOTE: Left (Right) Return Side Discharge can be converted to Left (Right) Return End Discharge or vice versa, without additional custom sheet metal parts. Horizontal units are normally suspended from a ceiling by six 1/2 in. diameter threaded rods. The rods are usually attached to the unit by hanger bracket kits furnished with each unit.

Lay out and install the threaded rods and 1 5/8" strut channel as shown in the Horizontal Dimensional Data. The unit should be pitched approximately 1/4 in. toward the drain in both directions to facilitate the removal of condensate.

Some applications require the installation of horizontal units on an attic floor. In this case, the unit should be set in a full size secondary drain pan on top of a vibration absorbing pad. The secondary drain pan prevents possible condensate overflow or water leakage damage to the ceiling. The secondary drain pan is usually placed on a plywood base isolated from the ceiling joists by additional layers of vibration absorbing material.



CAUTION: Do not use rods smaller than 1/2 in. diameter since they may not be strong enough to support the unit. The rods must be securely anchored to the ceiling.

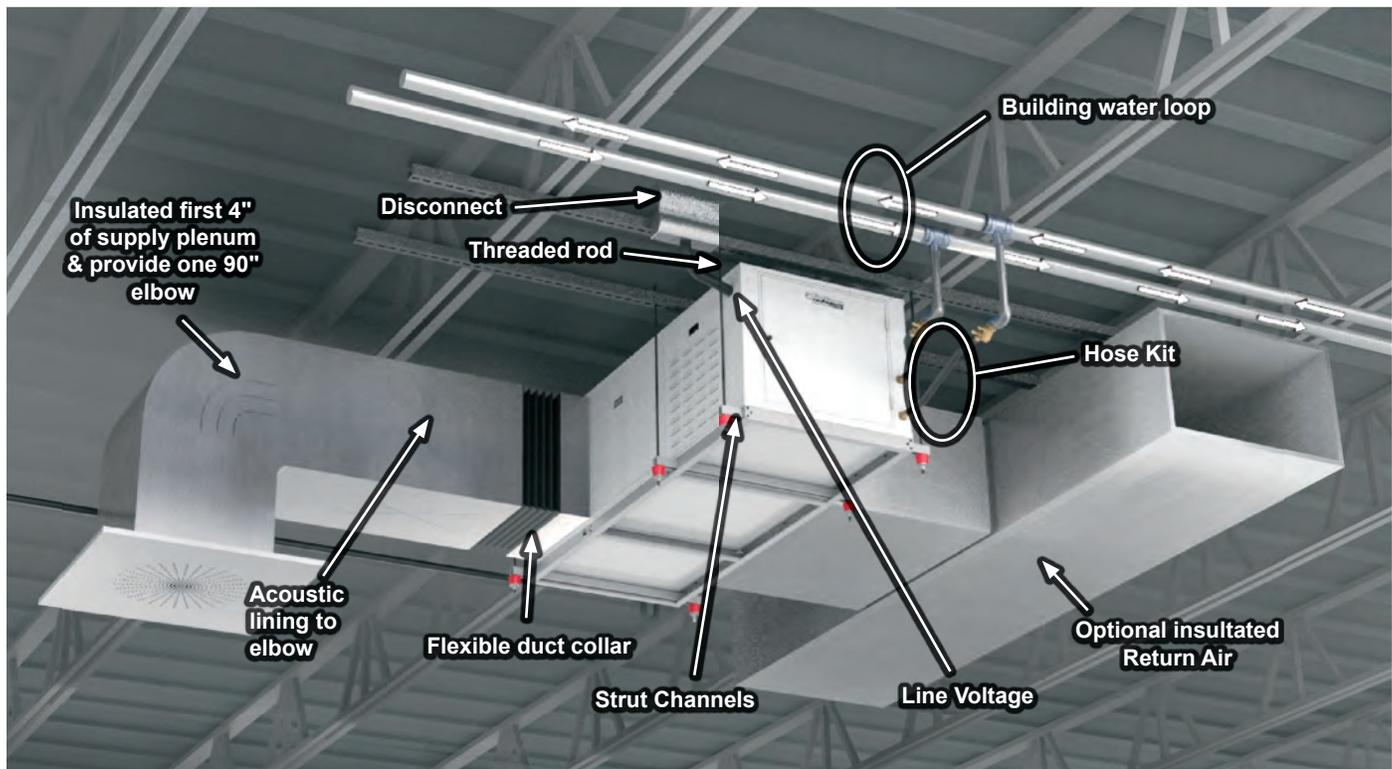

Installation Notes cont.

Acoustical Considerations and Equipment Sound Performance

Sound Performance

The unit is third party sound rated in accordance with ARI 260. Please consult Sound Performance Data Catalog for details on the AHRI standard and sound performance data.

Recommendations for Noise Reduction

Horizontal Unit Location

- Specify equipment with quietest sound power ratings
- Do not locate units above areas with a required NC 40 or less
- Space WSHP at least 10 ft (3m) apart to avoid noise summing of multiple units in a space.
- Maximize the height of the unit above the ceiling (horizontal).
- Suspend unit with isolation grommets that are appropriately rated to reduce vibrations (horizontal).

Vertical Unit Location

- Specify equipment with quietest sound power ratings
- Space WSHP at least 10 ft (3m) apart to avoid noise summing of multiple units in a space.
- Acoustic ceiling coatings can greatly reduce noise levels in mechanical rooms.
- Mount unit on a sound absorbing pad, extruded polystyrene, rubber or cork pad.

Ductwork

- Ensure return air grilles will not allow line of site noise to transfer to adjacent space. Use a sound barrier or some other material to isolate the grille from the unit. A supply grille, boot and short piece of flex duct pointed away from the unit can greatly attenuate equipment noise.
- Use a canvas isolation duct connector at the supply and return duct connection of the unit.
- Internally line the discharge and return duct within the first 4-8 feet of unit with acoustic insulation. Install an internally lined 'L' shaped return duct elbow at return grille. Face the elbow away from adjacent units.
- Always install at least one 90° elbow in the discharge duct to eliminate line of sight noise transmission of the blower.
- Use turning vanes at all elbows and tees to reduce turbulence.
- Limit supply duct velocities to less than 1,000 fpm
- Design and install ductwork as stiff as possible
- Allow 3 duct diameters both up and down stream of the unit before any fittings or transitions are installed.
- Use duct sealant on all duct joints.
- Install a short (2-4') of flex duct on all branch ducts just prior to discharge boot or diffuser to reduce vibration and duct sound prior to delivery in the room.
- Locate the branch duct balancing damper as far away from the diffuser as possible.
- In ceiling plenum systems, install an internally lined 'L' shaped return duct elbow at unit. Face the elbow away from adjacent units (horizontal).

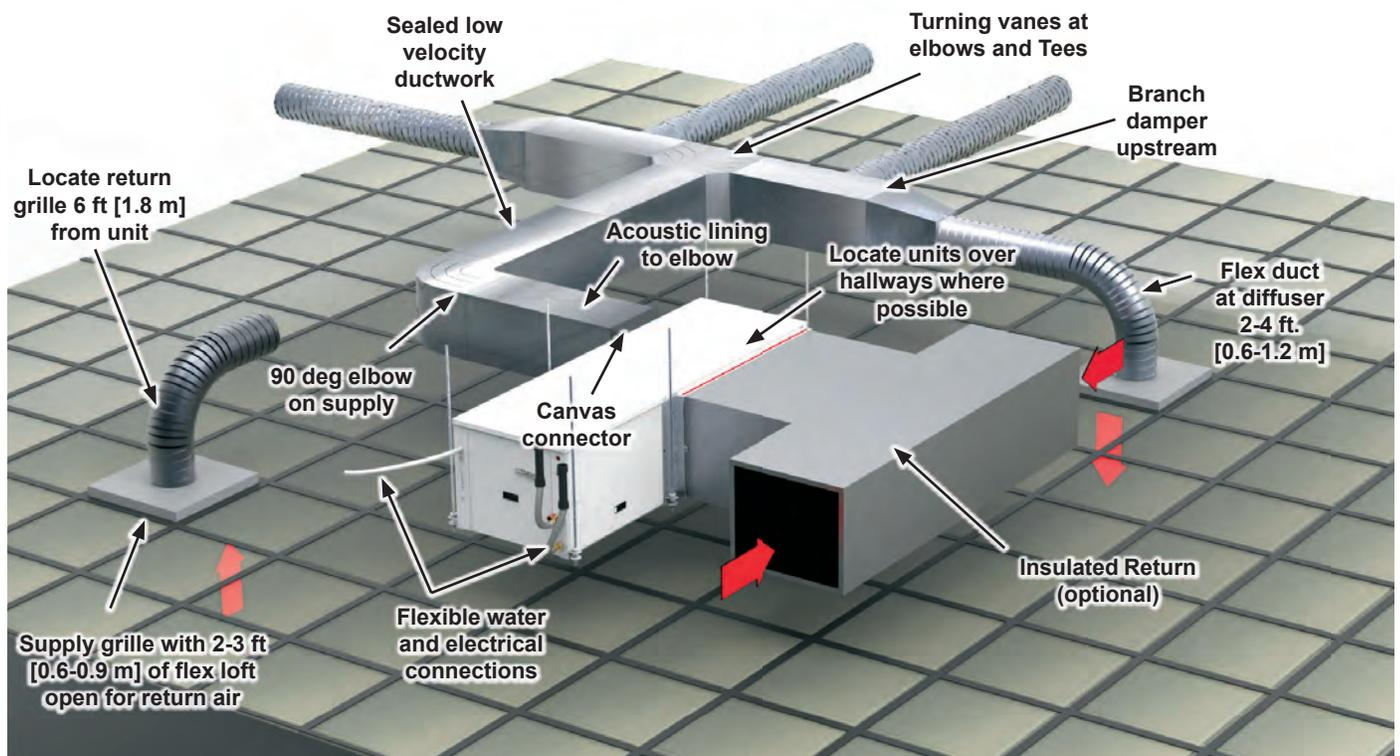

Dimensional Data

LEFT RETURN SHOWN

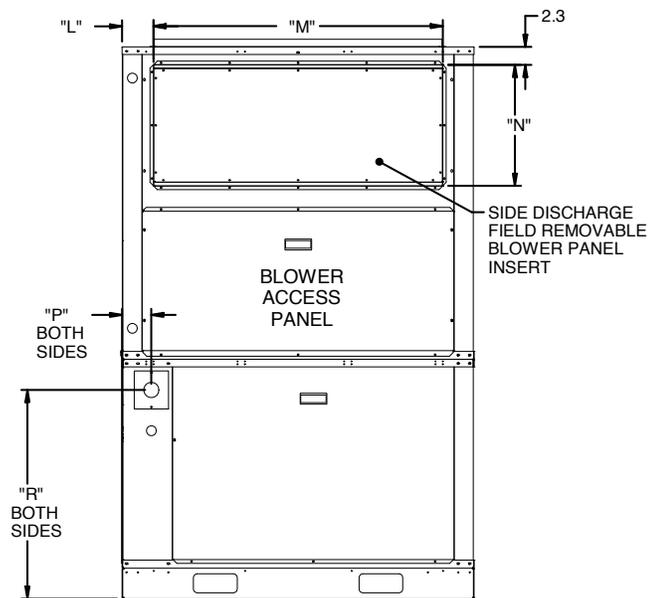
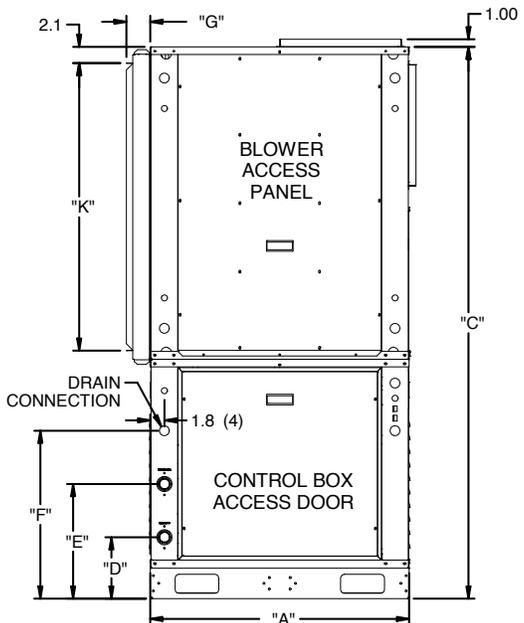
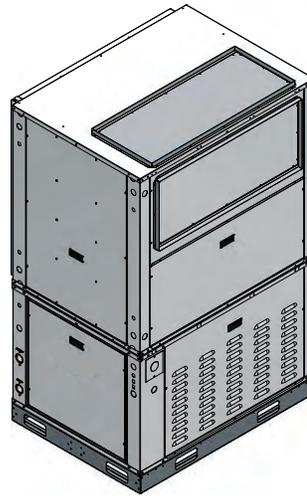
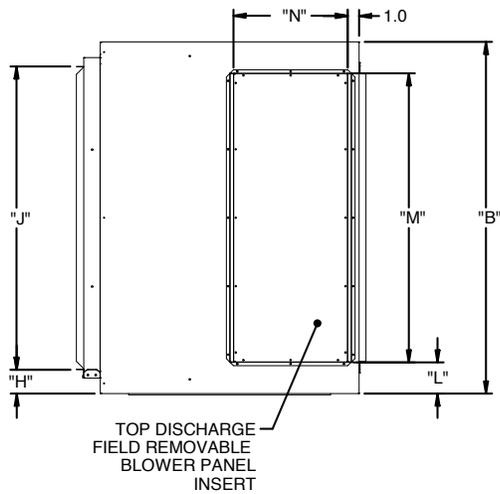

Vertical Dimensional Data

Vertical Models	Overall Cabinet			Water Connections				Return Connection*				Discharge Connection			Electrical Connections		
	A	B	C	1	2	3	Loop Water FPT	using deluxe filter rack				L	M	N	P	R	
	Width	Depth	Height	D	E	F		G	H	J	K						From Edge
084-096	in.	34.0	36.3	72.5	8.1	15.1	22.1	1 1/4"	3.1	3.2	29.9	37.8	4.1	28.0	16.0	3.9	27.4
	cm.	86.4	92.2	184.2	20.6	38.4	56.1	31.8 mm	7.9	8.1	75.9	96.0	10.4	71.1	40.6	9.9	69.6
120	in.	34.0	36.3	72.5	8.1	15.1	22.1	2"	3.1	3.2	29.9	37.8	4.1	28.0	16.0	3.9	27.4
	cm.	86.4	92.2	184.2	20.6	38.4	56.1	50.8 mm	7.9	8.1	75.9	96.0	10.4	71.1	40.6	9.9	69.6
150-180	in.	34.0	46.3	72.5	8.1	15.1	22.1	2"	3.1	2.2	39.9	37.8	4.1	38.0	16.0	3.9	27.4
	cm.	86.4	117.5	184.2	20.6	38.4	56.1	50.8 mm	7.9	5.6	101.3	96.0	10.4	96.5	40.6	9.9	69.6

*Dimensions for return connections are for the deluxe filter rack that is suitable for ducted return applications

Dimensional Data cont.

LEFT RETURN SHOWN

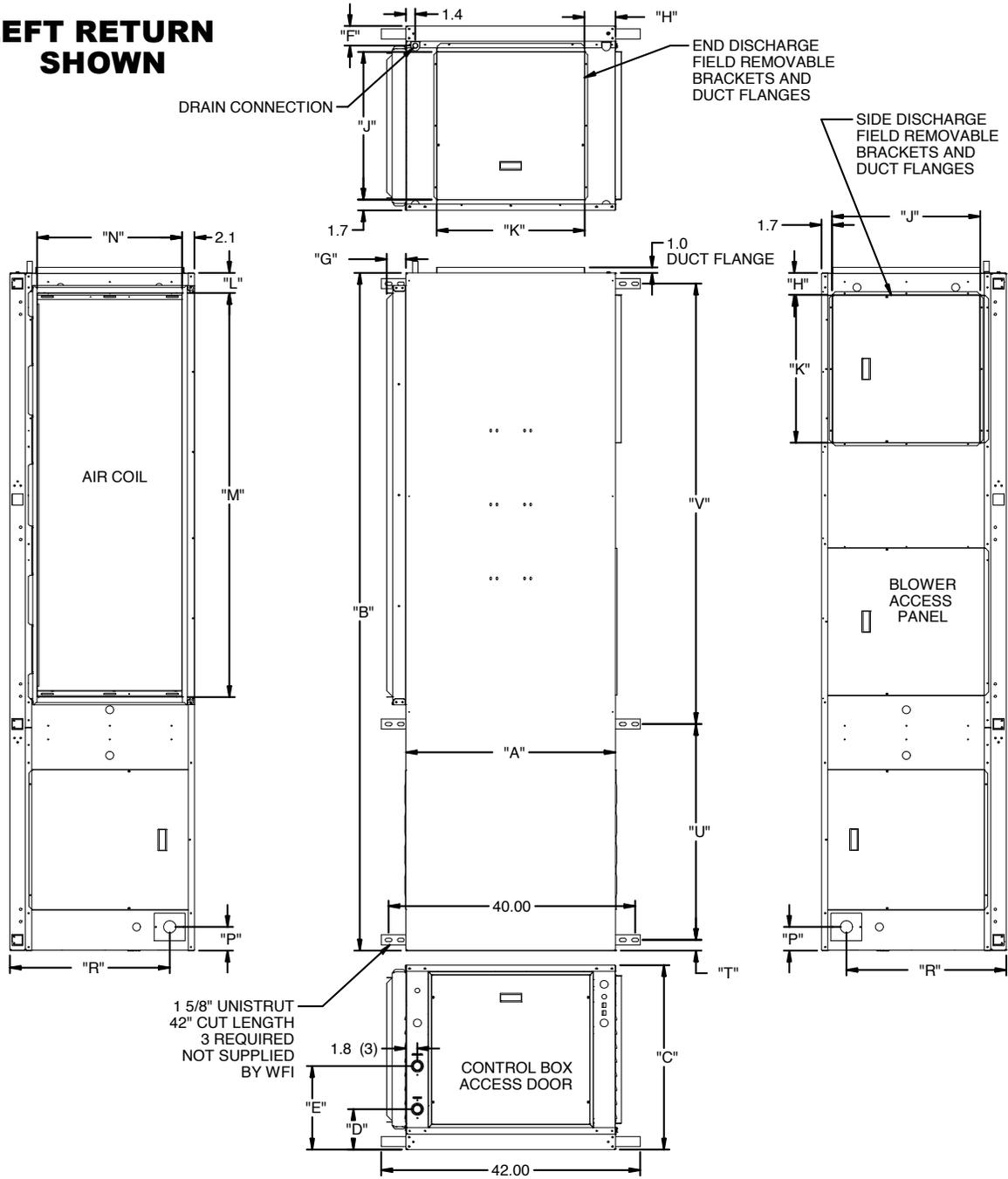

Horizontal Dimensional Data

Horizontal Models	Overall Cabinet			Water Connections					Discharge Connection				Return Connection*			Electrical Connections		Unistrut Hanging		
	A	B	C	1	2	5		G	H	J	K	L	M	N	P	R	T	U	V	
	Width	Depth	Height	In	Out	Condensate	Water FPT	Filter Rack Width	From Edge	Supply Height	Supply Width	From Edge	Return Depth	Return Height	From Edge	Height	From Edge	Unistrut/Unistrut	Unistrut/Unistrut	
	in.	in.	in.	in.	in.	in.	in.	in.	in.	in.	in.	in.	in.	in.	in.	in.	in.	in.	in.	
084-096	in.	34.0	89.0	29.9	8.1	15.1	3.2	1 1/4"	3.1	5.0	24.0	24.0	4.3	47.6	23.5	3.9	25.9	1.7	24.6	61.0
	cm.	86.4	226.1	75.9	20.6	38.4	8.1	31.8 mm	7.9	12.7	61.0	61.0	10.9	120.9	59.7	9.9	65.8	4.3	62.5	154.9
120	in.	34.0	89.0	29.9	8.1	15.1	3.2	2"	3.1	5.0	24.0	24.0	4.3	47.6	23.5	3.9	25.9	1.7	24.6	61.0
	cm.	86.4	226.1	75.9	20.6	38.4	8.1	50.8 mm	7.9	12.7	61.0	61.0	10.9	120.9	59.7	9.9	65.8	4.3	62.5	154.9
150-180	in.	34.0	110.0	29.9	8.1	15.1	3.2	2"	3.1	5.0	24.0	24.0	4.3	65.6	23.5	3.9	25.9	1.7	35.1	71.5
	cm.	86.4	279.4	75.9	20.6	38.4	8.1	50.8 mm	7.9	12.7	61.0	61.0	10.9	166.6	59.7	9.8	65.8	4.3	89.2	181.6

*Dimensions for return connections are for the deluxe filter rack that is suitable for ducted return applications

Dimensional Data cont.

240-360 RIGHT RETURN SHOWN

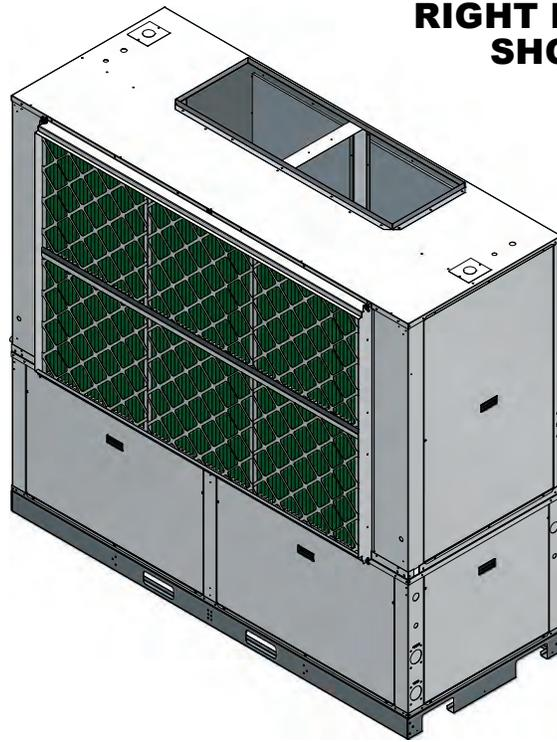
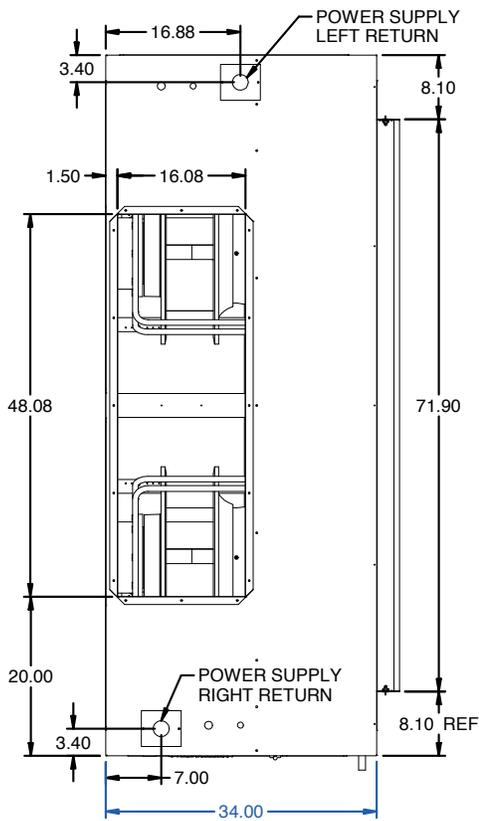

TOP DISCHARGE
FIELD REMOVABLE
BLOWER PANEL
INSERT

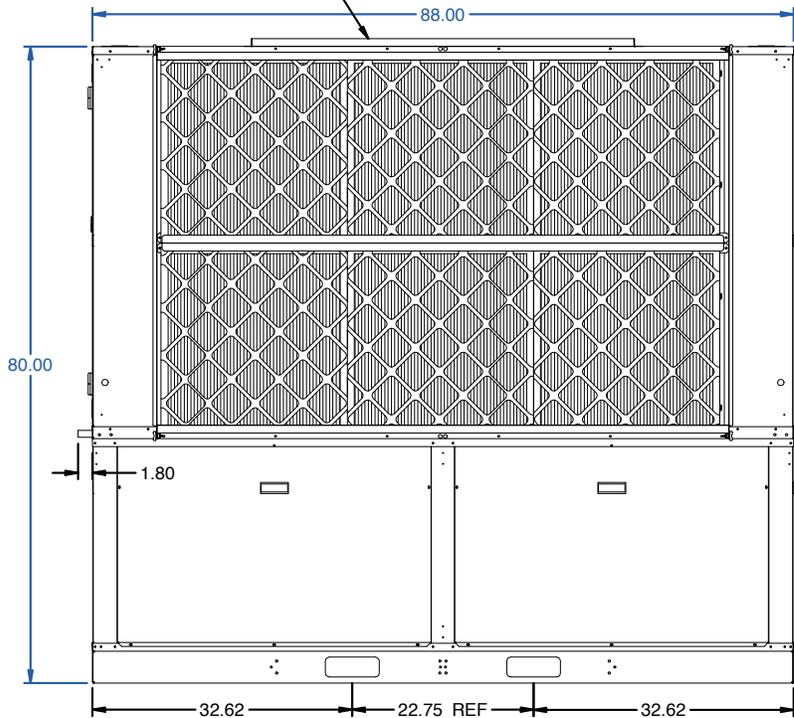
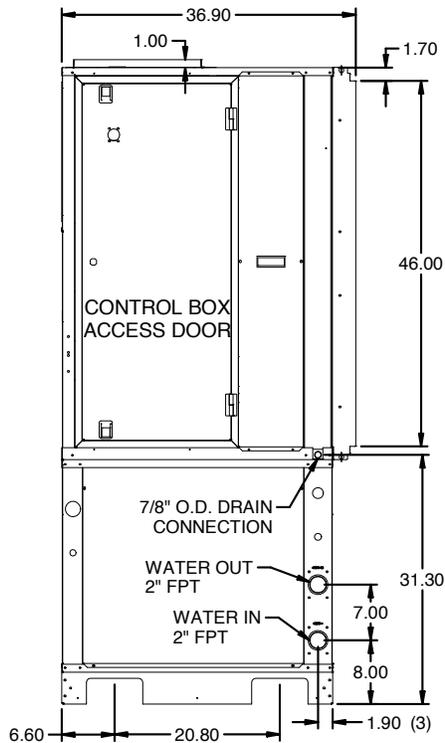

Physical Data

Model	Dual Capacity Compressor and Fan			Two Compressors and Fan		Two Compressors and Two Fans		
	084	096	120	150	180	240	300	360
Compressor	Scroll (1 each)			Scroll (2 each)		Scroll (2 each)		
Factory Charge R410A, oz [kg] (each circuit), Vertical	130 [3.69]	132 [3.74]	190 [5.39]	112 [3.18]	128 [3.63]	196 [5.57]	224 [6.35]	230 [6.52]
Factory Charge R410A, oz [kg] (each circuit), Horizontal	126 [3.57]	130 [3.69]	176 [4.99]	112 [3.18]	126 [3.57]	N/A	N/A	N/A
Blower Motor & Blower								
Blower Motor - Quantity	1	1	1	1	1	2	2	2
Blower Motor Type/Speeds	Backward Curve VS ECM							
Blower Motor 230V - hp [kW]	4.56 [3.4]	4.8 [3.6]	4.8 [3.6]	4.8 [3.6]	4.8 [3.6]	4.8 [3.6]	4.8 [3.6]	4.8 [3.6]
Blower Motor 460V - hp [kW]	5.5 [4.1]	7.2 [5.4]	7.2 [5.4]	7.2 [5.4]	7.2 [5.4]	7.2 [5.4]	7.2 [5.4]	7.2 [5.4]
Blower Wheel Size (Dia), in. [mm]	15.7 [400]	19.7 [500]	19.7 [500]	19.7 [500]	19.7 [500]	19.7 [500]	19.7 [500]	19.7 [500]
Coax and Water Piping								
Water Connections Size - FPT - in [mm]	1/4 [31.75]	1/4 [31.75]	2 [50.8]	2 [50.8]	2 [50.8]	2 [50.8]	2 [50.8]	2 [50.8]
Coax & Piping Water Volume - gal [l]	1.47 [5.56]	1.47 [5.56]	2.01 [7.61]	2.38 [9.01]	2.72 [10.29]	3.57 [13.53]	4.83 [18.29]	5.26 [19.92]
Vertical Air Coil & Filters								
Air Coil Dimensions (H x W), in. [mm]	40 x 30 [1016 x 762]	40 x 30 [1016 x 762]	40 x 40 [1016 x 1016]	40 x 38.5 [1016 x 978]	40 x 38.5 [1016 x 978]	48 x 67.5 [1219 x 1715]	48 x 67.5 [1219 x 1715]	48 x 67.5 [1219 x 1715]
Air Coil Total Face Area, ft2 [m2]	8.34 [0.77]	8.34 [0.77]	11.11 [1.03]	10.69 [0.99]	10.69 [0.99]	22.5 [2.09]	22.5 [2.09]	22.5 [2.09]
Air Coil Tube Size, in [mm]	3/8 [9.5]	3/8 [9.5]	3/8 [9.5]	3/8 [9.5]	3/8 [9.5]	3/8 [9.5]	3/8 [9.5]	3/8 [9.5]
Air Coil Number of rows	3	3	4	4	4	3	3	3
Filter Standard - 1" [25mm] Pleated MERV 4 Throwaway, in [mm]	40 x 32 [1016 x 813]	40 x 32 [1016 x 813]	40 x 32 [1016 x 813]	42 x 40 [1067 x 1016]	42 x 40 [1067 x 1016]	6- 24 x 24 [610 x 610]	6- 24 x 24 [610 x 610]	6- 24 x 24 [610 x 610]
Filter Standard - 2" [51mm] Pleated MERV 8 Throwaway, in [mm]	40 x 32 [1016 x 813]	40 x 32 [1016 x 813]	40 x 32 [1016 x 813]	42 x 40 [1067 x 1016]	42 x 40 [1067 x 1016]	6- 24 x 24 [610 x 610]	6- 24 x 24 [610 x 610]	6- 24 x 24 [610 x 610]
Filter Standard - 2" [51mm] Pleated MERV 13 Throwaway, in [mm]	40 x 32 [1016 x 813]	40 x 32 [1016 x 813]	40 x 32 [1016 x 813]	42 x 40 [1067 x 1016]	42 x 40 [1067 x 1016]	6- 24 x 24 [610 x 610]	6- 24 x 24 [610 x 610]	6- 24 x 24 [610 x 610]
Filter Standard - 4" [102mm] Pleated MERV 13 Throwaway, in [mm]	40 x 32 [1016 x 813]	40 x 32 [1016 x 813]	40 x 32 [1016 x 813]	42 x 40 [1067 x 1016]	42 x 40 [1067 x 1016]	6- 24 x 24 [610 x 610]	6- 24 x 24 [610 x 610]	6- 24 x 24 [610 x 610]
Horizontal Air Coil & Filters								
Air Coil Dimensions (H x W), in. [mm]	26 x 48 [660 x 1219]	26 x 48 [660 x 1219]	26 x 48 [660 x 1219]	26 x 64 [660 x 1626]	26 x 64 [660 x 1626]			
Air Coil Total Face Area, ft2 [m2]	8.67 [0.81]	8.67 [0.81]	8.67 [0.81]	11.56 [1.07]	11.56 [1.07]			
Air Coil Tube Size, in [mm]	3/8 [9.5]	3/8 [9.5]	3/8 [9.5]	3/8 [9.5]	3/8 [9.5]			
Air Coil Number of rows	3	3	4	4	4			
Filter Standard - 1" [25mm] Pleated MERV 4 Throwaway, in [mm]	2 - 25 x 25 [635 x 635]	2 - 25 x 25 [635 x 635]	2 - 25 x 25 [635 x 635]	2 - 25 x 25 [635 x 635] 1- 18 x 25 [457 x 635]	2 - 25 x 25 [635 x 635] 1- 18 x 25 [457 x 635]			
Filter Standard - 2" [51mm] Pleated MERV 13 Throwaway, in [mm]	2 - 25 x 25 [635 x 635]	2 - 25 x 25 [635 x 635]	2 - 25 x 25 [635 x 635]	2 - 25 x 25 [635 x 635] 1- 18 x 25 [457 x 635]	2 - 25 x 25 [635 x 635] 1- 18 x 25 [457 x 635]			
Filter Standard - 4" [102mm] Pleated MERV 13 Throwaway, in [mm]	2 - 25 x 25 [635 x 635]	2 - 25 x 25 [635 x 635]	2 - 25 x 25 [635 x 635]	2 - 25 x 25 [635 x 635] 1- 18 x 25 [457 x 635]	2 - 25 x 25 [635 x 635] 1- 18 x 25 [457 x 635]			

3/30/2021

Electrical Data

Electrical Table 7-30 Ton Plenum Fan

	Model	Rated Voltage	Voltage Min/Max	Compressor (each)			Blower Motor (each) FLA	Total Unit FLA	Min Circ Amp	Max Fuse/HACR Breaker
				MCC	RLA	LRA				
Dual Capacity Compressor	084	208-230/60/3	187/253	39.5	23.3	184.0	5.3	28.6	34.4	55
		460/60/3	414/506	15.0	8.8	84.0	3.0	11.8	14.0	20
		575/60/3	518/632	13.1	8.4	60.0	2.4	10.8	12.9	20
	096	208-230/60/3	187/253	41.9	24.7	164.0	7.0	31.7	37.9	60
		460/60/3	414/506	18.7	11.0	94.0	4.0	15.0	17.8	25
		575/60/3	518/632	14.0	9.0	65.0	3.2	12.2	14.5	20
	120	208-230/60/3	187/253	50.8	30.0	240.0	7.0	37.0	44.5	70
		460/60/3	414/506	23.1	13.6	130.0	4.0	17.6	21.0	30
		575/60/3	518/632	17.3	11.1	93.7	3.2	14.3	17.1	25
Two Compressors & Plenum Fan	150	208-230/60/3	187/253	29.7	19.0	123.0	9.2	47.2	52.0	70
		460/60/3	414/506	15.2	9.7	62.0	6.8	26.2	28.6	35
		575/60/3	518/632	11.6	7.4	50.0	5.4	20.2	22.1	25
	180	208-230/60/3	187/253	39.0	25.0	164.0	9.2	59.2	65.5	90
		460/60/3	414/506	20.0	12.8	100.0	6.8	32.4	35.6	45
		575/60/3	518/632	15.0	9.6	78.0	5.4	24.6	27.0	35
Two Compressors & Two Plenum Fans	240	208-230/60/3	187/253	44.0	28.2	240.0	9.2	74.8	81.9	110
		460/60/3	414/506	23.0	14.7	130.0	6.8	43.0	46.7	60
		575/60/3	518/632	17.6	11.3	93.7	5.4	33.5	36.3	45
	300	208-230/60/3	187/253	75.0	48.1	245.0	9.2	114.6	126.6	175
		460/60/3	414/506	29.0	18.6	125.0	6.8	50.8	55.5	70
		575/60/3	518/632	23.0	14.7	100.0	5.4	40.3	44.0	55
	360	208-230/60/3	187/253	75.0	48.1	351.0	9.2	114.6	126.6	175
		460/60/3	414/506	38.6	24.7	197.0	6.8	63.0	69.2	90
		575/60/3	518/632	35.0	22.4	135.0	5.4	55.7	61.3	80

HACR circuit breaker in USA only

3/30/2021

Blower Performance Data

Integrated EC Backward Curved Plenum Fan Performance

Model 084

Fan Speed	Fan RPM	Airflow [cfm] at External Static Pressure [in. wg.]																				
		0.0	0.1	0.2	0.3	0.4	0.5	0.6	0.7	0.8	0.9	1.0	1.1	1.2	1.3	1.4	1.5	1.6	1.7	1.8	1.9	2.0
1	900	1395	1315	1215	1090	940	775	495														
2	1100	1725	1640	1570	1485	1400	1280	1150	1015	870	620											
3	1300	2055	1985	1925	1865	1800	1725	1645	1550	1435	1315	1190	1060	1055	870							
4	1400	2220	2165	2100	2045	1990	1915	1850	1770	1685	1595	1490	1375	1260	1105	955						
5	1600	2555	2505	2435	2390	2335	2285	2230	2175	2110	2045	1970	1885	1800	1705	1605	1510	1375	1265			
6	1700	2715	2660	2610	2545	2505	2460	2415	2365	2305	2250	2180	2125	2050	1970	1885	1800	1695	1600	1495	1350	1275
7	1800	2810	2785	2705	2655	2600	2540	2495	2415	2355	2305	2265	2210	2175	2120	2085	2015	1965	1905	1855	1795	1705
8	1900	2970	2910	2865	2805	2775	2715	2665	2615	2575	2520	2460	2405	2360	2300	2245	2185	2130	2075	2020	1965	1895
9	2000	3145	3105	3075	3015	2945	2900	2855	2805	2745	2695	2655	2585	2520	2475	2430	2380	2305	2245	2175	2100	2030
10	2100	3320	3300	3285	3225	3115	3085	3045	2995	2915	2870	2850	2765	2680	2650	2615	2575	2480	2415	2330	2235	2165
11	2200	3460	3410	3380	3315	3245	3240	3195	3120	3085	3050	3020	2985	2915	2865	2805	2780	2715	2635	2575	2520	2475
12	2300	3625	3575	3505	3460	3425	3395	3345	3245	3255	3230	3190	3165	3120	3075	3025	2990	2950	2885	2820	2785	2715

Fan selection is accomplished through the Aurora Controls and allows four online selections of continuous fan (G), L = stage 1 (Y1), H = stage 2 (Y2), and Aux = electric heat. 3/30/21

Continuous Fan (G) can be set at any airflow. Factory setting is 1.

L = Stage 1 (Y1) factory setting is 3.

H = Stage 2 (Y2) factory setting is 8.

Electric Heat Operation (AUX) = Stage 3 factory setting is 10.

Elect heat Airflow (AUX) airflow setting should be configured for the minimum airflow needed to support the heater. Please consult heater manual.

Model 096

Fan Speed	Fan RPM	Airflow [cfm] at External Static Pressure [in. wg.]																				
		0.0	0.1	0.2	0.3	0.4	0.5	0.6	0.7	0.8	0.9	1.0	1.1	1.2	1.3	1.4	1.5	1.6	1.7	1.8	1.9	2.0
1	600	1530	1430	1205	915	525	420															
2	700	1835	1710	1530	1410	1165	870	495														
3	800	2145	2030	1895	1740	1565	1385	1125	825	570												
4	900	2530	2415	2290	2145	1985	1825	1665	1440	1200	920											
5	1000	2815	2720	2620	2505	2365	2235	2085	1915	1755	1555	1325	1115	780								
6	1100	3135	3045	2955	2830	2735	2615	2470	2335	2195	2045	1915	1745	1490	1315							
7	1200	3440	3360	3275	3195	3095	2985	2895	2750	2645	2505	2375	2225	2085	1915	1730	1525	1235				
8	1300	3745	3685	3595	3505	3415	3335	3235	3120	3035	2910	2795	2680	2555	2420	2305	2150	1955	1770	1575		
9	1400	4045	3995	3905	3830	3775	3680	3580	3500	3415	3310	3195	3165	2985	2875	2750	2630	2505	2375	2255	2070	1905
10	1500	4370	4285	4220	4150	4085	4010	3920	3850	3775	3680	3595	3505	3400	3305	3195	3075	2940	2830	2750	2645	2525
11	1600	4875	4575	4545	4480	4400	4335	4250	4200	4115	4065	3975	3865	3795	3695	3600	3500	3395	3290	3180	3085	2970
12	1700	5200	5120	5060	5000	4935	4665	4575	4510	4415	4345	4280	4210	4130	4040	3960	3875	3795	3680	3605	3515	3425

Fan selection is accomplished through the Aurora Controls and allows four online selections of continuous fan (G), L = stage 1 (Y1), H = stage 2 (Y2), and Aux = electric heat. 3/30/21

Continuous Fan (G) can be set at any airflow. Factory setting is 1.

L = Stage 1 (Y1) factory setting is 4.

H = Stage 2 (Y2) factory setting is 7.

Electric Heat Operation (AUX) = Stage 3 factory setting is 10.

Elect heat Airflow (AUX) airflow setting should be configured for the minimum airflow needed to support the heater. Please consult heater manual.

Model 120

Fan Speed	Fan RPM	Airflow [cfm] at External Static Pressure [in. wg.]																				
		0.0	0.1	0.2	0.3	0.4	0.5	0.6	0.7	0.8	0.9	1.0	1.1	1.2	1.3	1.4	1.5	1.6	1.7	1.8	1.9	2.0
1	700	1835	1710	1530	1410	1165	870	495														
2	800	2145	2030	1895	1740	1565	1385	1125	825	570												
3	900	2530	2415	2290	2145	1985	1825	1665	1440	1200	920											
4	1000	2815	2720	2620	2505	2365	2235	2085	1915	1755	1555	1325	1115	780								
5	1100	3135	3045	2955	2830	2735	2615	2470	2335	2195	2045	1915	1745	1490	1315							
6	1200	3440	3360	3275	3195	3095	2985	2895	2750	2645	2505	2375	2225	2085	1915	1730	1525	1235				
7	1300	3745	3685	3595	3505	3415	3335	3235	3120	3035	2910	2795	2680	2555	2420	2305	2150	1955	1770	1575		
8	1400	4045	3995	3905	3830	3775	3680	3580	3500	3415	3310	3195	3165	2985	2875	2750	2630	2505	2375	2255	2070	1905
9	1500	4370	4285	4220	4150	4085	4010	3920	3850	3775	3680	3595	3505	3400	3305	3195	3075	2940	2830	2750	2645	2525
10	1600	4875	4775	4545	4480	4400	4335	4250	4200	4115	4065	3975	3865	3795	3695	3600	3500	3395	3290	3180	3085	2970
11	1700	5200	5120	5060	5000	4935	4665	4575	4510	4415	4345	4280	4210	4130	4040	3960	3875	3795	3680	3605	3515	3425
12	1800	5525	5405	5310	5200	5105	4995	4860	4755	4695	4625	4555	4480	4410	4350	4295	4225	4160	4070	3985	3900	3820

Fan selection is accomplished through the Aurora Controls and allows four online selections of continuous fan (G), L = stage 1 (Y1), H = stage 2 (Y2), and Aux = electric heat. 3/30/21

Continuous Fan (G) can be set at any airflow. Factory setting is 1.

L = Stage 1 (Y1) factory setting is 4.

H = Stage 2 (Y2) factory setting is 8.

Electric Heat Operation (AUX) = Stage 3 factory setting is 10.

Elect heat Airflow (AUX) airflow setting should be configured for the minimum airflow needed to support the heater. Please consult heater manual.

Blower Performance Data cont.

Model 150

Fan Speed	Fan RPM	Airflow [cfm] at External Static Pressure [in. wg.]																				
		0.0	0.1	0.2	0.3	0.4	0.5	0.6	0.7	0.8	0.9	1.0	1.1	1.2	1.3	1.4	1.5	1.6	1.7	1.8	1.9	2.0
1	900	2780	2665	2545	2400	2230	2055	1880	1650													
2	1000	3095	2990	2885	2780	2675	2515	2345	2175	2005	1830	1590										
3	1100	3415	3325	3230	3135	3045	2905	2795	2680	2570	2460	2155	1985									
4	1200	3750	3660	3565	3470	3370	3275	3165	3055	2935	2805	2680	2530	2375	2195	1995						
5	1300	4055	3980	3905	3815	3725	3635	3540	3445	3335	3215	3100	2975	2845	2700	2545	2385	2190	1995	1802		
6	1400	4375	4305	4230	4155	4070	3985	3900	3815	3720	3620	3520	3395	3275	3160	3040	2925	2765	2605	2445	2285	2120
7	1500	4810	4700	4585	4495	4420	4345	4255	4170	4090	4015	3945	3840	3735	3635	3530	3425	3295	3165	3035	2895	2765
8	1600	5245	5095	4940	4835	4770	4685	4605	4525	4450	4385	4320	4225	4135	4035	3945	3855	3745	3640	3530	3415	3300
9	1700	5680	5490	5295	5175	5120	5025	4955	4880	4810	4755	4680	4600	4520	4435	4345	4255	4175	4090	4000	3895	3795
10	1800	6115	5885	5650	5515	5470	5365	5305	5235	5170	5125	5040	4975	4905	4835	4730	4650	4570	4490	4405	4315	4220
11	1900	6550	6280	6005	5855	5820	5705	5655	5590	5530	5495	5400	5350	5290	5235	5115	5045	4965	4890	4810	4735	4645
12	2000	6985	6675	6360	6195	6155	6045	6005	5945	5890	5865	5760	5725	5675	5635	5500	5440	5360	5290	5215	5155	5070

Fan selection is accomplished through the Aurora Controls and allows four online selections of continuous fan (G), L = stage 1 (Y1), 3/30/21

H = stage 2 (Y2), and Aux = electric heat.

Continuous Fan (G) can be set at any airflow. Factory setting is 1.

L = Stage 1 (Y1) factory setting is 2.

H = Stage 2 (Y2) factory setting is 9.

Electric Heat Operation (AUX) = Stage 3 factory setting is 10.

Elect heat Airflow (AUX) airflow setting should be configured for the minimum airflow needed to support the heater. Please consult heater manual.

Model 180

Fan Speed	Fan RPM	Airflow [cfm] at External Static Pressure [in. wg.]																				
		0.0	0.1	0.2	0.3	0.4	0.5	0.6	0.7	0.8	0.9	1.0	1.1	1.2	1.3	1.4	1.5	1.6	1.7	1.8	1.9	2.0
1	900	2454	2341	2214	2075	1923	1758	1580	1389													
2	1000	2978	2881	2773	2669	2531	2407	2253	2087	1908	1679	1432										
3	1100	3288	3202	3121	3012	2908	2800	2679	2521	2385	2230	2050	1839	1617	1281							
4	1200	3587	3507	3433	3343	3249	3145	3037	2926	2791	2659	2490	2364	2218	2037	1825	1568					
5	1300	3901	3835	3761	3664	3594	3507	3418	3319	3202	3104	2969	2864	2735	2581	2417	2230	2098	1928			
6	1400	4244	4182	4120	4057	3974	3896	3809	3727	3629	3536	3455	3326	3224	3110	2983	2833	2718	2581	2440	2293	
7	1550	4812	4738	4664	4587	4504	4438	4372	4291	4226	4134	4046	3962	3870	3780	3707	3579	3501	3404	3305	3204	3101
8	1700	5329	5262	5195	5139	5082	5020	4958	4895	4831	4752	4673	4601	4529	4455	4380	4294	4222	4145	4068	3990	3911
9	1800	5666	5607	5548	5481	5414	5353	5291	5221	5151	5086	5020	4953	4886	4811	4735	4671	4596	4523	4450	4375	4300
10	1900	6018	5957	5895	5833	5770	5712	5654	5589	5524	5463	5402	5340	5278	5208	5138	5047	4976	4907	4837	4766	4695
11	2000	6350	6287	6224	6165	6105	6045	5985	5923	5861	5799	5736	5672	5607	5541	5475	5414	5347	5281	5214	5148	5080
12	2160	6862	6805	6748	6698	6647	6588	6529	6477	6425	6364	6303	6249	6194	6131	6068	5987	5920	5854	5787	5721	5653

Fan selection is accomplished through the Aurora Controls and allows four online selections of continuous fan (G), L = stage 1 (Y1), 3/30/21

H = stage 2 (Y2), and Aux = electric heat.

Continuous Fan (G) can be set at any airflow. Factory setting is 1.

L = Stage 1 (Y1) factory setting is 3.

H = Stage 2 (Y2) factory setting is 9.

Electric Heat Operation (AUX) = Stage 3 factory setting is 10.

Elect heat Airflow (AUX) airflow setting should be configured for the minimum airflow needed to support the heater. Please consult heater manual.

Blower Performance Data cont.

Model 240

Fan Speed	Fan RPM	Airflow [cfm] at External Static Pressure [in. wg.]																				
		0.0	0.1	0.2	0.3	0.4	0.5	0.6	0.7	0.8	0.9	1.0	1.1	1.2	1.3	1.4	1.5	1.6	1.7	1.8	1.9	2.0
1	900	5755	5525	5290	5005	4725	5045	4075	3645	3205	2635											
2	1000	6610	6345	6080	5815	5550	5285	5020	4725	4425	4035	3640	3155									
3	1100	7465	7165	6870	6625	6375	5525	5965	5805	5400	5105	4810	4440	4075	3495	2915						
4	1200	7815	7650	7485	7295	7105	6915	6725	6540	6355	6095	5835	5540	5245	4755	4265	3995	3730	3075			
5	1300	8505	8355	8205	8040	7875	7705	7530	7335	7145	6925	6710	6505	6300	5975	5655	5165	4681	4568	4455	3870	3285
6	1400	9195	9020	8850	8705	8565	8395	8225	8060	7895	7710	7525	7355	7190	6975	6760	6380	6000	5500	5000	4600	4200
7	1500	9885	9785	9605	9470	9335	9180	9025	8895	8770	8575	8385	8215	8045	7850	7655	7415	7175	6740	6305	5870	5435
8	1600	10575	10545	10360	10235	10105	9930	9760	9605	9450	9325	9205	9045	8890	8725	8565	8385	8205	8005	7810	7565	7325
9	1700	11265	11105	11055	11000	10875	10680	10570	10435	10300	10160	10025	9880	9740	9590	9445	9275	9110	8880	8655	8275	7900
10	1800	11955	11860	11750	11695	11645	11430	11380	11265	11150	10995	10715	10595	10480	10340	10205	10065	9930	9770	9610	9305	9005
11	1900	12645	12615	12445	12390	12285	12180	12105	12085	12000	11830	11405	11310	11220	11090	10975	10845	10715	10565	10420	10280	10145
12	2000	13335	13230	13140	13085	12925	12885	12830	12755	12705	12665	12395	12025	11960	11840	11745	11625	11500	11360	11225	11085	10945

Fan selection is accomplished through the Aurora Controls and allows four online selections of continuous fan (G), L = stage 1 (Y1), H = stage 2 (Y2), and Aux = electric heat. 3/30/21

Continuous Fan (G) can be set at any airflow. Factory setting is 1.

L = Stage 1 (Y1) factory setting is 3.

H = Stage 2 (Y2) factory setting is 6.

Electric Heat Operation (AUX) = Stage 3 factory setting is 8.

Elect heat Airflow (AUX) airflow setting should be configured for the minimum airflow needed to support the heater. Please consult heater manual.

Model 300

Fan Speed	Fan RPM	Airflow [cfm] at External Static Pressure [in. wg.]																				
		0.0	0.1	0.2	0.3	0.4	0.5	0.6	0.7	0.8	0.9	1.0	1.1	1.2	1.3	1.4	1.5	1.6	1.7	1.8	1.9	2.0
1	900	5755	5525	5290	5005	4725	5045	4075	3645	3205	2635											
2	1000	6610	6345	6080	5815	5550	5285	5020	4725	4425	4035	3640	3155									
3	1100	7465	7165	6870	6625	6375	5525	5965	5805	5400	5105	4810	4440	4075	3495	2915						
4	1200	7815	7650	7485	7295	7105	6915	6725	6540	6355	6095	5835	5540	5245	4755	4265	3995	3730	3075			
5	1300	8505	8355	8205	8040	7875	7705	7530	7335	7145	6925	6710	6505	6300	5975	5655	5165	4681	4568	4455	3870	3285
6	1400	9195	9020	8850	8705	8565	8395	8225	8060	7895	7710	7525	7355	7190	6975	6760	6380	6000	5500	5000	4600	4200
7	1500	9885	9785	9605	9470	9335	9180	9025	8895	8770	8575	8385	8215	8045	7850	7655	7415	7175	6740	6305	5870	5435
8	1600	10575	10545	10360	10235	10105	9930	9760	9605	9450	9325	9205	9045	8890	8725	8565	8385	8205	8005	7810	7565	7325
9	1700	11265	11105	11055	11000	10875	10680	10570	10435	10300	10160	10025	9880	9740	9590	9445	9275	9110	8880	8655	8275	7900
10	1800	11955	11860	11750	11695	11645	11430	11380	11265	11150	10995	10715	10595	10480	10340	10205	10065	9930	9770	9610	9305	9005
11	1900	12645	12615	12445	12390	12285	12180	12105	12085	12000	11830	11405	11310	11220	11090	10975	10845	10715	10565	10420	10280	10145
12	2000	13335	13230	13140	13085	12925	12885	12830	12755	12705	12665	12395	12025	11960	11840	11745	11625	11500	11360	11225	11085	10945

Fan selection is accomplished through the Aurora Controls and allows four online selections of continuous fan (G), L = stage 1 (Y1), H = stage 2 (Y2), and Aux = electric heat. 3/30/21

Continuous Fan (G) can be set at any airflow. Factory setting is 1.

L = Stage 1 (Y1) factory setting is 3.

H = Stage 2 (Y2) factory setting is 8.

Electric Heat Operation (AUX) = Stage 3 factory setting is 9.

Elect heat Airflow (AUX) airflow setting should be configured for the minimum airflow needed to support the heater. Please consult heater manual.

Model 360

Fan Speed	Fan RPM	Airflow [cfm] at External Static Pressure [in. wg.]																				
		0.0	0.1	0.2	0.3	0.4	0.5	0.6	0.7	0.8	0.9	1.0	1.1	1.2	1.3	1.4	1.5	1.6	1.7	1.8	1.9	2.0
1	900	5755	5525	5290	5005	4725	5045	4075	3645	3205	2635											
2	1000	6610	6345	6080	5815	5550	5285	5020	4725	4425	4035	3640	3155									
3	1100	7465	7165	6870	6625	6375	5525	5965	5805	5400	5105	4810	4440	4075	3495	2915						
4	1200	7815	7650	7485	7295	7105	6915	6725	6540	6355	6095	5835	5540	5245	4755	4265	3995	3730	3075			
5	1300	8505	8355	8205	8040	7875	7705	7530	7335	7145	6925	6710	6505	6300	5975	5655	5165	4681	4568	4455	3870	3285
6	1400	9195	9020	8850	8705	8565	8395	8225	8060	7895	7710	7525	7355	7190	6975	6760	6380	6000	5500	5000	4600	4200
7	1500	9885	9785	9605	9470	9335	9180	9025	8895	8770	8575	8385	8215	8045	7850	7655	7415	7175	6740	6305	5870	5435
8	1600	10575	10545	10360	10235	10105	9930	9760	9605	9450	9325	9205	9045	8890	8725	8565	8385	8205	8005	7810	7565	7325
9	1700	11265	11105	11055	11000	10875	10680	10570	10435	10300	10160	10025	9880	9740	9590	9445	9275	9110	8880	8655	8275	7900
10	1800	11955	11860	11750	11695	11645	11430	11380	11265	11150	10995	10715	10595	10480	10340	10205	10065	9930	9770	9610	9305	9005
11	1900	12645	12615	12445	12390	12285	12180	12105	12085	12000	11830	11405	11310	11220	11090	10975	10845	10715	10565	10420	10280	10145
12	2000	13335	13230	13140	13085	12925	12885	12830	12755	12705	12665	12395	12025	11960	11840	11745	11625	11500	11360	11225	11085	10945

Fan selection is accomplished through the Aurora Controls and allows four online selections of continuous fan (G), L = stage 1 (Y1), H = stage 2 (Y2), and Aux = electric heat. 3/30/21

Continuous Fan (G) can be set at any airflow. Factory setting is 1.

L = Stage 1 (Y1) factory setting is 4.

H = Stage 2 (Y2) factory setting is 9.

Electric Heat Operation (AUX) = Stage 3 factory setting is 10.

Elect heat Airflow (AUX) airflow setting should be configured for the minimum airflow needed to support the heater. Please consult heater manual.

Blower Performance Data cont.

Setting Blower Speed - Variable Speed ECM

The ABC board's Yellow Config LED will flash the current ECM blower speed selections for G, low, and high continuously with a short pause in between. The speeds can also be confirmed with the AID Tool under the Setup/ECM Setup screen. The Aux will not be flashed but can be viewed in the AID Tool. The ECM blower motor speeds can be field adjusted with or without using an AID Tool.

Variable speed ECM Setup without an AID Tool

The blower speeds for G only, Low (Y1), and High (Y2/Aux) can be adjusted directly at the Aurora ABC board which utilizes the push button (SW1) on the ABC board. This procedure is outlined in the ECM Configuration Mode portion of the Aurora 'Base' Control System section. The Aux cannot be set manually without an AID Tool.

Variable speed ECM Setup with an AID Tool

A much easier method utilizes the AID Tool to change the airflow using the procedure below. First navigate to the Setup screen and then select ECM Setup. This screen displays the current ECM settings. It allows the technician

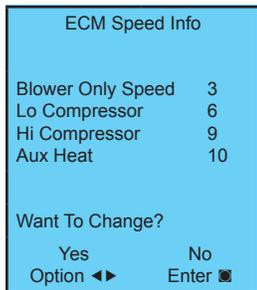

to enter the setup screens to change the ECM settings. Change the highlighted item using the ◀ and ▶ buttons and then press the ■ button to select the item.

Selecting YES will enter ECM speed setup, while selecting NO will return to the previous screen.

ECM Speed Setup - These screens allow the technician to select the G, low, high, and auxiliary heat blower speed for the ECM blower motor. Change the highlighted item using the ▲ and ▼ buttons. Press the ■ button to select the speed.

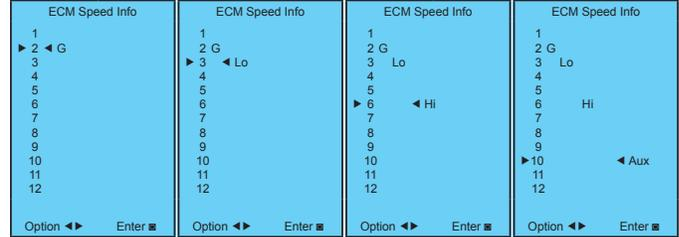

After the auxiliary heat speed setting is selected the AID Tool will automatically transfer back to the ECM Setup screen.

Cooling Airflow Setup - These screens allow the technician to select -15%, -10%, -5%, None or +5% change from the heating airflow. Change the adjustment percentage using the ▲ and ▼ buttons. Press the ■ button to save the change.

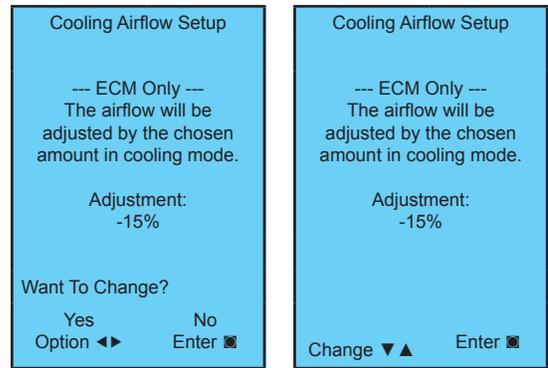

Selection Example

To achieve optimal performance, proper selection of each heat pump is essential. A building load program should be used to determine the heating and cooling load of each zone. A computer software selection program can then be used to develop an accurate and complete heat pump schedule. Software can be obtained from your local factory representative.

While a computer software program is the easiest and most accurate method to size and select equipment, however, selection can still be accomplished manually using this manual and the following selection procedure. Sizing so that the actual sensible capacity of the equipment will satisfy the sensible capacity of the zone is the recommended method for best results.

Boiler/Tower Application

Typical boiler/tower application will result in entering water temperatures of 60-90°F with 70°F for heating and 90°F for cooling. Water to refrigerant insulation option would not be required. Flow rates are 2.5 to 3 gpm per ton with 2.5 gpm per ton often representing an economical design point.

Geothermal Application

Typical geothermal application can result in a wide entering water temperature range of 30-100°F. Typically minimum heating entering water temperatures can range from 30 to 50°F depending upon loop type and geographical location. Cooling performance should be calculated using a maximum loop temperature of 100°F in most loop applications. Water flow is typically 2.5 to 3 gpm per ton with 3 gpm per ton recommended with the more extreme loop temperatures. **PLEASE NOTE THAT WATER COIL INSULATION OPTION SHOULD BE SELECTED WHEN ENTERING WATER TEMPERATURES ARE EXPECTED TO BE BELOW 45-50°F.**

Geothermal Selection Example

Step 1: Determine the actual heating and cooling loads at the desired dry bulb and wet bulb conditions.

Step 2: Obtain the following design parameters: Entering water temperature, water flow rate in gpm, airflow in cfm, water flow pressure drop and design wet and dry bulb temperatures. Airflow, cfm, should be between 300 and 450 cfm per ton. Unit water pressure drop should be kept as close as possible to each other to make water balancing easier. Go to the appropriate tables and find the proper indicated water flow and water temperature.

Step 3: Select a unit based on total and sensible cooling conditions. Select a unit which is closest to, but no larger than, the actual cooling load.

Step 4: Enter tables at the design water flow and water temperature. Read the total and sensible cooling capacities (**NOTE:** interpolation is permissible, extrapolation is not).

Step 5: Read the heating capacity. If it exceeds the design criteria it is acceptable. It is quite normal for water source heat pumps to be selected on cooling capacity only since the heating output is usually greater than the cooling capacity.

Step 6: Determine the correction factors associated with the variable factors of dry bulb and wet bulb.

Corrected Total Cooling = tabulated total cooling x wet bulb correction.

Corrected Sensible Cooling = tabulated sensible cooling x wet/dry bulb correction.

Step 7: Compare the corrected capacities to the load requirements. Normally if the capacities are within 10% of the loads, the equipment is acceptable. It is better to undersize than oversize, as undersizing improves humidity control, reduces sound levels and extends the life of the equipment.

Step 8: When complete, calculate water temperature rise and assess the selection. If the units selected are not within 10% of the load calculations, then review what effect changing the gpm, water temperature and/or airflow and air temperature would have on the corrected capacities. If the desired capacity cannot be achieved, select the next larger or smaller unit and repeat the procedure. Remember, when in doubt, undersize slightly for best performance.

Example Equipment Selection - Cooling

1. Load Determination:

Assume we have determined that the appropriate cooling load at the desired dry bulb 80°F and wet bulb 65°F conditions is as follows:

Total Cooling	135,000 Btu/hr
Sensible Cooling	87,000 Btu/hr
Entering Air temperature.....	75°F Dry Bulb/ 65°F Wet Bulb

2. Design Conditions:

Similarly, we have also obtained the following design parameters:

Entering Water Temperature	90°F
Water Flow (Based upon 10°F rise in temperature)	36.0 gpm
Airflow Required	4,200 cfm @ 0.5 in. wg.

Selection Example cont.

3, 4, & 5. HP Selection:

After making our preliminary selection (*150) we enter the tables at design water flow and water temperature and read Total Cooling, Sens Cooling and Heat of Rej. capacities:

Total Cooling147,300 Btu/hr
 Sensible Cooling109,100 Btu/hr
 Heat of Rejection181,200 Btu/hr

6 & 7. Entering Cooling Capacity and Airflow Corrections:

Next, we determine our correction factors. (Refer to Cooling Capacity, and Airflow Correction Tables - 4,200/4,500 nom = 93% as percent of nominal

Corrected Total Cooling = 147,300 x 0.967 x 0.992 = 141,230
 Corrected Sensible Cooling = 109,100 x 0.881 x 0.965 = 92,753
 Corrected Heat of Rejection = 181,200 x 0.972 x 0.990 = 174,365

8. Water Temperature Rise Calculation & Assessment:

$$HR = 500 \times \text{gpm} \times (T_{in} - T_{out})$$

$$\frac{HR}{500 \times \text{gpm}} = (T_{in} - T_{out}) \text{ or } \Delta T \text{ Rise}$$

$$\frac{174,365}{500 \times 36} = 9.7 \text{ } ^\circ\text{F Rise}$$

Note: 500 = parameters for water & 485 = parameters for antifreeze solutions to 30% weight.

When we compare the Corrected Total Cooling and Corrected Sensible Cooling figures with our load requirements stated in Step 1, we discover that our selection is within + 10% of our sensible load requirement. Furthermore, we see that our Corrected Total cooling figure is within 2,000 Btu/hr of the actual indicated load.

Antifreeze Corrections

Catalog performance can be corrected for antifreeze use. Please use the following table and note the example given.

Antifreeze Type	Antifreeze % by wt	Cooling Capacity	Heating Capacity	Pressure Drop
EWT - degF [DegC]		90 [32.2]	30 [-1.1]	30 [-1.1]
Water	0	1.000	1.000	1.000
Ethylene Glycol	10	0.991	0.973	1.075
	20	0.979	0.943	1.163
	30	0.965	0.917	1.225
	40	0.955	0.890	1.324
	50	0.943	0.865	1.419
Propylene Glycol	10	0.981	0.958	1.130
	20	0.969	0.913	1.270
	30	0.950	0.854	1.433
	40	0.937	0.813	1.614
	50	0.922	0.770	1.816
Ethanol	10	0.991	0.927	1.242
	20	0.972	0.887	1.343
	30	0.947	0.856	1.383
	40	0.930	0.815	1.523
	50	0.911	0.779	1.639
Methanol	10	0.986	0.957	1.127
	20	0.970	0.924	1.197
	30	0.951	0.895	1.235
	40	0.936	0.863	1.323
	50	0.920	0.833	1.399

Warning: Gray area represents antifreeze concentrations greater than 35% by weight and should be avoided due to the extreme performance penalty they represent.

Antifreeze Correction Example

Antifreeze solution is Propylene Glycol 20% by weight. Determine the corrected full load heating and cooling performance at 30°F and 90°F respectively as well as pressure drop at 30°F for a *120 model.

The corrected cooling capacity at 90°F would be: 117,200 Btu/h x 0.969 = 113,567 Btu/h

The corrected heat capacity at 30°F would be: 86,200 Btu/h x 0.913 = 78,701 Btu/h

The corrected pressure drop at 30°F and 30gpm would be: 6.9 ft. hd. x 1.270 = 8.8 ft. hd.

Reference Calculations

Heating Calculations:	Cooling Calculations:
$\text{LWT} = \text{EWT} - \frac{\text{HE}}{\text{gpm} \times 500}$	$\text{LWT} = \text{EWT} + \frac{\text{HR}}{\text{gpm} \times 500}$
$\text{LAT} = \text{EAT} + \frac{\text{HC}}{\text{cfm} \times 1.08}$	$\text{LAT(DB)} = \text{EAT(DB)} - \frac{\text{SC}}{\text{cfm} \times 1.08}$
$\text{TH} = \text{HC} + \text{HWC}$	$\text{LC} = \text{TC} - \text{SC}$
	$\text{S/T} = \frac{\text{SC}}{\text{TC}}$

Legend and Notes

ABBREVIATIONS AND DEFINITIONS:

cfm = airflow, cubic feet/minute	HE = total heat of extraction, MBtu/h
EWT = entering water temperature, Fahrenheit	HWC = hot water generator capacity, MBtu/h
gpm = water flow in gallons/minute	EER = Energy Efficient Ratio = BTU output/Watt input
WPD = water pressure drop, psi and feet of water	COP = Coefficient of Performance = Btu output/Btu input
EAT = entering air temperature, Fahrenheit (dry bulb/wet bulb)	LWT = leaving water temperature, °F
HC = air heating capacity, MBtu/h	LAT = leaving air temperature, °F
TC = total cooling capacity, MBtu/h	TH = total heating capacity, MBtu/h
SC = sensible cooling capacity, MBtu/h	LC = latent cooling capacity, MBtu/h
kW = total power unit input, kilowatts	S/T = sensible to total cooling ratio
HR = total heat of rejection, MBtu/h	

Notes (Refer to Performance Data tables)

- Performance ratings are based on 80°F DB / 67°F WB EAT for cooling and 70°F DB EAT for heating.
- Three flow rates are shown for each unit. The lowest flow rate shown is used for geothermal open loop/well water systems with a minimum of 50°F EWT. The middle flow rate shown is the minimum geothermal closed loop flow rate. The highest flow rate shown is optimum for geothermal closed loop systems and the suggested flow rate for boiler/tower applications.
- The hot water generator numbers are based on a flow rate of 0.4 gpm/ton of rated capacity with an EWT of 90°F.
- Entering water temperatures below 40°F assumes 15% antifreeze solution.
- For non-standard EAT conditions, apply the appropriate correction factors on (Refer to Correction Factor Tables).
- Interpolation between EWT, gpm, and cfm data is permissible.

Operating Limits

Operating Limits	Cooling		Heating	
	(°F)	(°C)	(°F)	(°C)
Air Limits				
Min. Ambient Air	45	7.2	45	7.2
Rated Ambient Air	80	26.7	70	21.1
Max. Ambient Air	100	37.8	85	29.4
Min. Entering Air	50	10.0	40	4.4
Rated Entering Air db/wb	80.6/66.2	27/19	68	20.0
Max. Entering Air db/wb	110/83	43/28.3	80	26.7
Water Limits				
Min. Entering Water	30	-1.1	20	-6.7
Normal Entering Water	50-110	10-43.3	30-70	-1.1
Max. Entering Water	120	48.9	90	32.2

NOTE: Minimum/maximum limits are only for start-up conditions, and are meant for bringing the space up to occupancy temperature. Units are not designed to operate at the minimum/maximum conditions on a regular basis. The operating limits are dependent upon three primary factors: 1) water temperature, 2) return air temperature, and 3) ambient temperature. When any of the factors are at the minimum or maximum levels, the other two factors must be at the normal level for proper and reliable unit operation.

Cooling Capacity Corrections

Entering Air WB °F	Total Clg Cap	Sensible Cooling Capacity Multipliers - Entering DB °F										Power Input	Heat of Rejection
		60	65	70	75	80	80.6	85	90	95	100		
55	0.898	0.723	0.866	1.048	1.185	*	*	*	*	*	*	0.985	0.913
60	0.912		0.632	0.880	1.078	1.244	1.260	*	*	*	*	0.994	0.927
65	0.967			0.694	0.881	1.079	1.085	1.270	*	*	*	0.997	0.972
66.2	0.983			0.655	0.842	1.040	1.060	1.232	*	*	*	0.999	0.986
67	1.000			0.616	0.806	1.000	1.023	1.193	1.330	*	*	1.000	1.000
70	1.053				0.693	0.879	0.900	1.075	1.250	1.404	*	1.003	1.044
75	1.168					0.687	0.715	0.875	1.040	1.261	1.476	1.007	1.141

NOTE: * Sensible capacity equals total capacity at conditions shown.

11/10/09

Heating Corrections

Ent Air DB °F	Htg Cap	Power	Heat of Ext
45	1.062	0.739	1.158
50	1.050	0.790	1.130
55	1.037	0.842	1.096
60	1.025	0.893	1.064
65	1.012	0.945	1.030
68	1.005	0.976	1.012
70	1.000	1.000	1.000
75	0.987	1.048	0.970
80	0.975	1.099	0.930

11/10/09

Operating Limits cont.

Air Flow Corrections (Part Load)

Airflow		Cooling				Heating		
CFM Per Ton of Clg	% of Nominal	Total Cap	Sens Cap	Power	Heat of Rej	Htg Cap	Power	Heat of Ext
240	60	0.922	0.778	0.956	0.924	0.943	1.239	0.879
275	69	0.944	0.830	0.962	0.944	0.958	1.161	0.914
300	75	0.957	0.866	0.968	0.958	0.968	1.115	0.937
325	81	0.970	0.900	0.974	0.970	0.977	1.075	0.956
350	88	0.982	0.933	0.981	0.980	0.985	1.042	0.972
375	94	0.991	0.968	0.991	0.991	0.993	1.018	0.988
400	100	1.000	1.000	1.000	1.000	1.000	1.000	1.000
425	106	1.007	1.033	1.011	1.008	1.007	0.990	1.010
450	113	1.013	1.065	1.023	1.015	1.012	0.987	1.018
475	119	1.017	1.099	1.037	1.022	1.018	0.984	1.025
500	125	1.020	1.132	1.052	1.027	1.022	0.982	1.031
520	130	1.022	1.159	1.064	1.030	1.025	0.979	1.034

1/4/18

Air Flow Corrections (Full Load)

Airflow		Cooling				Heating		
CFM Per Ton of Clg	% of Nominal	Total Cap	Sens Cap	Power	Heat of Rej	Htg Cap	Power	Heat of Ext
240	60	0.922	0.786	0.910	0.920	0.943	1.150	0.893
275	69	0.944	0.827	0.924	0.940	0.958	1.105	0.922
300	75	0.959	0.860	0.937	0.955	0.968	1.078	0.942
325	81	0.971	0.894	0.950	0.967	0.977	1.053	0.959
350	88	0.982	0.929	0.964	0.978	0.985	1.031	0.973
375	94	0.992	0.965	0.982	0.990	0.993	1.014	0.988
400	100	1.000	1.000	1.000	1.000	1.000	1.000	1.000
425	106	1.007	1.034	1.020	1.010	1.007	0.990	1.011
450	113	1.012	1.065	1.042	1.018	1.013	0.983	1.020
475	119	1.017	1.093	1.066	1.026	1.018	0.980	1.028
500	125	1.019	1.117	1.092	1.033	1.023	0.978	1.034
520	130	1.020	1.132	1.113	1.038	1.026	0.975	1.038

1/4/18

Pressure Drop

Model	GPM	Pressure Drop (psi)					
		30°F	50°F	70°F	90°F	110°F	
Dual Capacity Compressor	084	10.0	1.7	1.5	1.3	1.0	0.8
		16.0	3.5	3.3	3.1	2.9	2.7
		22.0	7.1	6.0	5.33	4.9	4.7
	096	12.0	1.4	1.2	1.0	0.8	0.6
		18.0	2.8	2.6	2.4	2.2	2.0
		24.0	4.9	4.6	4.4	4.2	4.0
	120	16.0	0.8	0.7	0.7	0.6	0.5
		22.0	1.5	1.3	1.2	1.2	1.1
		30.0	3.0	2.8	2.6	2.4	2.2
Two Compressor	150	24.0	3.2	3.0	2.8	2.6	2.4
		30.0	5.1	4.9	4.7	4.5	4.3
		36.0	6.9	6.7	6.5	6.3	6.1
	180	22.0	1.8	1.6	1.4	1.2	1.0
		34.0	3.0	2.8	2.6	2.4	2.2
		45.0	4.2	4.0	3.6	3.3	3.1
	240	35.0	1.8	1.6	1.5	1.4	1.2
		50.0	3.0	2.8	2.6	2.4	2.2
		60.0	6.0	5.8	5.6	5.3	5.1
	300	35.0	2.8	2.6	2.4	2.2	2.0
		50.0	4.2	4.0	3.8	3.6	3.4
		75.0	7.6	7.3	7.0	6.4	6.0
	360	50.0	3.4	3.2	3.0	2.8	2.6
		70.0	6.1	5.9	5.7	5.5	5.3
		90.0	8.7	8.5	8.3	8.1	7.9

3/30/21

084 - Part Load - Performance Data

Capacity Data (1700 CFM)

EWT °F	WATER FLOW GPM	WPD		HEATING - EAT 70 °F					COOLING - EAT 80/67 °F					
		PSI	FT	HC	KW	HE	LAT	COP	TC	SC	S/T	KW	HR	EER
20	8.0	1.6	3.7	Operation not recommended					Operation not recommended					
	10.0	1.8	4.2											
	16.0	3.6	8.3	38.3	3.02	28.0	88.9	3.72						
30	8.0	1.5	3.5	Operation not recommended					Operation not recommended					
	10.0	1.7	3.9	40.4	3.10	29.8	90.0	3.82	73.0	49.6	0.68	1.90	79.5	38.5
	16.0	3.5	8.1	41.0	3.14	30.3	90.3	3.83	74.0	50.6	0.68	1.78	80.1	41.6
40	8.0	1.4	3.2	43.1	3.18	32.3	91.5	3.97	72.1	46.1	0.64	2.10	79.3	34.3
	10.0	1.6	3.7	47.8	3.38	36.2	94.0	4.14	71.1	45.8	0.64	1.99	77.9	35.6
	16.0	3.4	7.9	47.5	3.33	36.1	93.9	4.18	72.0	45.9	0.64	1.84	78.3	39.2
50	8.0	1.3	3.0	52.4	3.43	40.7	96.5	4.47	68.8	42.3	0.61	2.16	76.2	31.9
	10.0	1.5	3.5	52.8	3.45	41.0	96.8	4.48	69.1	42.0	0.61	2.09	76.2	33.0
	16.0	3.3	7.6	54.0	3.52	42.0	97.4	4.50	70.0	41.1	0.59	1.89	76.4	37.0
60	8.0	1.2	2.8	58.3	3.51	46.3	99.8	4.87	65.3	41.0	0.63	2.53	73.9	25.9
	10.0	1.4	3.2	58.7	3.53	46.7	100.0	4.88	65.6	40.9	0.62	2.46	74.0	26.6
	16.0	3.2	7.4	60.1	3.60	47.8	100.7	4.90	66.7	40.9	0.61	2.28	74.4	29.2
70	8.0	1.1	2.5	64.2	3.58	52.0	103.0	5.25	61.8	39.6	0.64	2.89	71.7	21.4
	10.0	1.3	3.0	64.7	3.61	52.4	103.2	5.26	62.2	39.9	0.64	2.84	71.9	21.9
	16.0	3.1	7.2	66.2	3.68	53.7	104.1	5.28	63.3	40.8	0.64	2.67	72.4	23.7
80	8.0	1.0	2.3	70.1	3.63	57.7	106.2	5.66	57.8	37.8	0.65	3.47	69.7	16.7
	10.0	1.2	2.8	71.0	3.67	58.5	106.7	5.67	58.9	38.4	0.65	3.31	70.2	17.8
	16.0	3.0	6.9	72.3	3.73	59.6	107.4	5.69	60.0	39.3	0.66	3.21	70.9	18.7
90	8.0	0.9	2.1	76.1	3.69	63.5	109.4	6.05	53.8	36.0	0.67	4.05	67.7	13.3
	10.0	1.0	2.3	77.2	3.73	64.5	110.1	6.06	55.5	37.0	0.67	3.86	68.7	14.4
	16.0	2.9	6.7	78.4	3.78	65.5	110.7	6.08	56.7	37.9	0.67	3.74	69.4	15.2
100	8.0	0.8	1.8	Operation not recommended					Operation not recommended					
	10.0	0.9	2.1						52.5	34.4	0.65	4.18	66.8	12.6
	16.0	2.8	6.5						53.3	34.7	0.65	4.05	67.2	13.2
110	8.0	0.7	1.6						Operation not recommended					
	10.0	0.8	1.8						49.0	30.9	0.63	4.48	64.3	10.9
	16.0	2.7	6.2						50.0	31.4	0.63	4.36	64.9	11.5
120	8.0	0.6	0.0	Operation not recommended										
	10.0	0.7	1.6	45.7	29.0	0.63	4.37	60.6	10.5					
	16.0	2.6	6.0	29.4	0.63	4.24	61.1	11.0						

Interpolation is permissible, extrapolation is not.

3/30/21

All entering air conditions are 80°F DB and 67°F WB in Cooling and 70°F DB in Heating.

All performance data is based upon the lower voltage of dual voltage units.

Operation below 60°F EWT requires optional insulated water/refrigerant circuit.

Operation below 40°F EWT is based upon 15% antifreeze solution.

See performance correction tables for operating conditions other than those listed above.

084 - Full Load - Performance Data

Capacity Data (2500 CFM)

EWT °F	WATER FLOW GPM	WPD		HEATING - EAT 70 °F					COOLING - EAT 80/67 °F					
		PSI	FT	HC	KW	HE	LAT	COP	TC	SC	S/T	KW	HR	EER
20	10.0	1.8	4.2	Operation not recommended					Operation not recommended					
	16.0	3.6	8.3	Operation not recommended					Operation not recommended					
	22.0	7.8	18.0	55.7	4.8	39.2	88.6	3.38	Operation not recommended					
30	10.0	1.7	3.9	Operation not recommended					Operation not recommended					
	16.0	3.5	8.1	64.1	5.05	46.9	91.8	3.72	93.7	64.3	0.69	3.64	106.1	25.7
	22.0	7.1	16.3	65.1	5.11	47.7	92.1	3.73	95.0	65.6	0.69	3.42	106.7	27.8
40	10.0	1.6	3.7	72.3	5.22	54.5	94.8	4.06	93.6	62.7	0.67	4.12	107.7	22.7
	16.0	3.4	7.9	73.9	5.30	55.8	95.4	4.09	94.9	63.9	0.67	3.81	107.9	24.9
	22.0	6.5	15.0	74.6	5.36	56.3	95.6	4.08	96.8	65.3	0.67	3.62	109.1	26.8
50	10.0	1.5	3.5	81.5	5.46	62.9	98.2	4.37	93.7	61.8	0.66	4.13	107.8	22.7
	16.0	3.3	7.6	82.7	5.53	63.9	98.6	4.39	96.1	63.4	0.66	3.97	109.7	24.2
	22.0	6.0	14.0	84.0	5.60	64.9	99.1	4.40	98.6	65.1	0.66	3.81	111.6	25.9
60	10.0	1.4	3.2	92.0	5.71	72.5	102.1	4.72	91.1	61.0	0.67	4.51	106.5	20.2
	16.0	3.2	7.4	93.5	5.79	73.7	102.6	4.73	93.5	62.6	0.67	4.34	108.3	21.5
	22.0	5.7	13.2	94.9	5.86	74.9	103.1	4.75	95.9	64.2	0.67	4.17	110.1	23.0
70	10.0	1.3	3.0	102.6	5.97	82.2	106.0	5.04	88.5	60.1	0.68	4.90	105.2	18.1
	16.0	3.1	7.2	104.2	6.04	83.6	106.6	5.05	90.8	61.7	0.68	4.71	106.8	19.3
	22.0	5.3	12.3	105.8	6.12	84.9	107.2	5.07	93.1	63.3	0.68	4.52	108.5	20.6
80	10.0	1.2	2.8	113.3	6.21	92.1	110.0	5.35	84.2	57.7	0.68	5.51	103.0	15.3
	16.0	3.0	6.9	115.0	6.29	93.6	110.6	5.36	86.7	59.3	0.68	5.25	104.6	16.5
	22.0	5.1	11.8	116.8	6.37	95.1	111.3	5.37	88.7	60.7	0.68	5.09	106.0	17.4
90	10.0	1.0	2.3	124.0	6.46	101.9	113.9	5.63	80.0	55.2	0.69	6.12	100.9	13.1
	16.0	2.9	6.7	125.9	6.54	103.6	114.6	5.64	82.5	57.0	0.69	5.84	102.5	14.1
	22.0	4.9	11.4	127.8	6.62	105.2	115.3	5.66	84.2	58.1	0.69	5.65	103.5	14.9
100	10.0	0.9	2.1	Operation not recommended					Operation not recommended					
	16.0	2.8	6.5	Operation not recommended					78.6	55.0	0.70	6.81	101.8	11.5
	22.0	4.8	11.1	Operation not recommended					79.8	55.4	0.69	6.59	102.3	12.1
110	10.0	0.8	1.8	Operation not recommended					Operation not recommended					
	16.0	2.7	6.2	Operation not recommended					73.8	52.0	0.70	7.74	100.2	9.5
	22.0	4.7	10.7	Operation not recommended					75.3	52.7	0.70	7.53	101.0	10.0
120	10.0	0.7	1.6	Operation not recommended					Operation not recommended					
	16.0	2.6	6.0	Operation not recommended					69.4	50.3	0.72	8.65	98.9	8.0
	22.0	4.5	10.4	Operation not recommended					70.9	51.0	0.72	8.40	99.5	8.4

Interpolation is permissible, extrapolation is not.

3/30/21

All entering air conditions are 80°F DB and 67°F WB in Cooling and 70°F DB in Heating.

All performance data is based upon the lower voltage of dual voltage units.

Operation below 60°F EWT requires optional insulated water/refrigerant circuit.

Operation below 40°F EWT is based upon 15% antifreeze solution.

See performance correction tables for operating conditions other than those listed above.

096 - Part Load - Performance Data

Capacity Data (1900 CFM)

EWT °F	WATER FLOW GPM	WPD		HEATING - EAT 70 °F					COOLING - EAT 80/67 °F					
		PSI	FT	HC	KW	HE	LAT	COP	TC	SC	S/T	KW	HR	EER
20	12.0	1.5	3.5	Operation not recommended					Operation not recommended					
	16.0	2.4	5.5											
	18.0	2.9	6.7	39.0	3.28	27.8	87.0	3.48						
30	12.0	1.4	3.2	Operation not recommended					Operation not recommended					
	16.0	2.3	5.3	45.4	3.36	33.9	90.1	3.96	80.5	52.2	0.65	2.11	87.7	38.2
	18.0	2.8	6.5	46.1	3.40	34.5	90.5	3.97	81.6	53.3	0.65	1.98	88.4	41.2
40	12.0	1.3	3.0	51.5	3.56	39.3	93.1	4.23	75.3	49.5	0.66	2.32	83.2	32.5
	16.0	2.2	5.1	52.7	3.72	40.0	93.7	4.15	78.1	51.5	0.66	2.24	85.7	34.9
	18.0	2.7	6.2	53.1	3.66	40.6	93.9	4.25	79.3	52.4	0.66	2.14	86.6	37.1
50	12.0	1.2	2.8	58.2	3.81	45.2	96.4	4.47	73.2	48.9	0.67	2.49	81.7	29.4
	16.0	2.1	4.9	59.4	3.88	46.2	96.9	4.49	75.7	50.7	0.67	2.36	83.8	32.0
	18.0	2.6	6.0	60.0	3.91	46.7	97.2	4.50	77.0	51.6	0.67	2.30	84.8	33.5
60	12.0	1.1	2.5	66.3	3.98	52.7	100.3	4.88	69.0	47.2	0.68	2.88	78.8	24.0
	16.0	2.0	4.6	67.7	4.05	53.8	101.0	4.90	71.5	48.8	0.68	2.73	80.8	26.2
	18.0	2.5	5.8	68.3	4.08	54.4	101.3	4.91	72.7	49.7	0.68	2.66	81.7	27.4
70	12.0	1.0	2.3	74.4	4.15	60.2	104.2	5.25	64.9	45.4	0.70	3.26	76.0	19.9
	16.0	1.9	4.4	75.9	4.22	61.5	105.0	5.27	67.2	47.0	0.70	3.09	77.7	21.7
	18.0	2.4	5.5	76.7	4.26	62.2	105.4	5.28	68.3	47.7	0.70	3.01	78.6	22.7
80	12.0	0.9	2.1	82.5	4.28	67.9	108.2	5.65	61.8	44.5	0.72	3.89	75.0	15.9
	16.0	1.8	4.2	83.9	4.34	69.1	108.9	5.66	63.8	45.9	0.72	3.71	76.5	17.2
	18.0	2.3	5.3	85.0	4.39	70.0	109.4	5.68	65.0	46.8	0.72	3.60	77.3	18.1
90	12.0	0.8	1.8	90.5	4.41	75.5	112.1	6.02	58.6	43.5	0.74	4.53	74.0	12.9
	16.0	1.7	3.9	91.9	4.47	76.7	112.8	6.03	60.4	44.9	0.74	4.32	75.2	14.0
	18.0	2.2	5.1	93.3	4.52	77.9	113.5	6.05	61.7	45.9	0.74	4.18	75.9	14.8
100	12.0	0.7	1.6	Operation not recommended					Operation not recommended					
	16.0	1.6	3.7						57.5	44.4	0.77	4.75	73.7	12.1
	18.0	2.1	4.9						58.3	44.7	0.77	4.60	74.0	12.7
110	12.0	0.6	1.4	Operation not recommended					Operation not recommended					
	16.0	1.5	3.5						53.9	42.9	0.80	5.15	71.5	10.5
	18.0	2.0	4.6						55.0	43.5	0.79	5.01	72.1	11.0
120	12.0	0.5	1.2	Operation not recommended					Operation not recommended					
	16.0	1.4	3.2						50.6	42.2	0.83	5.87	70.6	8.6
	18.0	1.9	4.4						51.7	42.8	0.83	5.70	71.1	9.1

Interpolation is permissible, extrapolation is not.

3/30/21

All entering air conditions are 80°F DB and 67°F WB in Cooling and 70°F DB in Heating.

All performance data is based upon the lower voltage of dual voltage units.

Operation below 60°F EWT requires optional insulated water/refrigerant circuit.

Operation below 40°F EWT is based upon 15% antifreeze solution.

See performance correction tables for operating conditions other than those listed above.

096 - Full Load - Performance Data

Capacity Data (2800 CFM)

EWT °F	WATER FLOW GPM	WPD		HEATING - EAT 70 °F					COOLING - EAT 80/67 °F					
		PSI	FT	HC	KW	HE	LAT	COP	TC	SC	S/T	KW	HR	EER
20	12.0	1.5	3.5	Operation not recommended					Operation not recommended					
	18.0	2.9	6.7	Operation not recommended					Operation not recommended					
	24.0	5.0	11.6	62.7	5.40	44.3	88.7	3.40						
30	12.0	1.4	3.2	Operation not recommended					Operation not recommended					
	18.0	2.8	6.5	72.7	5.73	53.1	92.0	3.72	102.6	71.6	0.70	4.21	116.9	24.4
	24.0	4.9	11.3	73.8	5.80	54.0	92.4	3.73	104.0	73.0	0.70	3.95	117.5	26.3
40	12.0	1.3	3.0	82.3	5.94	62.1	95.2	4.06	100.7	69.5	0.69	4.57	116.3	22.0
	18.0	2.7	6.2	83.9	5.99	63.4	95.7	4.10	103.9	71.2	0.69	4.44	119.1	23.4
	24.0	4.8	11.1	84.9	6.10	64.1	96.1	4.08	106.0	72.8	0.69	4.22	120.4	25.1
50	12.0	1.2	2.8	93.1	6.23	71.9	98.8	4.38	102.6	69.0	0.67	4.86	119.2	21.1
	18.0	2.6	6.0	94.6	6.31	73.0	99.3	4.39	105.3	70.8	0.67	4.68	121.3	22.5
	24.0	4.6	10.5	96.0	6.39	74.2	99.7	4.40	108.0	72.6	0.67	4.49	123.3	24.1
60	12.0	1.1	2.5	106.1	6.58	83.6	103.1	4.73	99.3	67.2	0.68	5.32	117.5	18.7
	18.0	2.5	5.8	107.7	6.66	85.0	103.6	4.74	101.9	69.0	0.68	5.12	119.4	19.9
	24.0	4.5	10.4	109.3	6.75	86.3	104.2	4.75	104.6	70.8	0.68	4.92	121.3	21.3
70	12.0	1.0	2.3	119.0	6.92	95.4	107.3	5.04	96.0	65.3	0.68	5.78	115.8	16.6
	18.0	2.4	5.5	120.8	7.01	96.9	108.0	5.05	98.6	67.1	0.68	5.56	117.6	17.7
	24.0	4.4	10.2	122.7	7.10	98.4	108.6	5.06	101.1	69.0	0.68	5.34	119.3	18.9
80	12.0	0.9	2.1	126.4	7.21	101.8	109.8	5.14	92.5	64.0	0.69	6.40	114.4	14.5
	18.0	2.3	5.3	128.4	7.30	103.5	110.5	5.15	95.2	65.9	0.69	6.11	116.0	15.6
	24.0	4.3	9.9	130.3	7.39	105.1	111.1	5.17	97.4	67.3	0.69	5.91	117.5	16.5
90	12.0	0.8	1.8	133.9	7.49	108.3	112.3	5.24	89.0	62.7	0.70	7.02	112.9	12.7
	18.0	2.2	5.1	135.9	7.59	110.0	113.0	5.25	91.8	64.6	0.70	6.70	114.6	13.7
	24.0	4.2	9.7	138.0	7.68	111.8	113.6	5.27	93.7	65.6	0.70	6.48	115.8	14.5
100	12.0	0.7	1.6	Operation not recommended					Operation not recommended					
	18.0	2.1	4.9						89.0	63.4	0.71	7.54	114.7	11.8
	24.0	4.1	9.5						90.3	63.9	0.71	7.30	115.3	12.4
110	12.0	0.6	1.4	Operation not recommended					Operation not recommended					
	18.0	2.0	4.6						85.3	61.3	0.72	8.35	113.8	10.2
	24.0	4.0	9.2						87.0	62.2	0.71	8.12	114.7	10.7
120	12.0	0.5	1.2	Operation not recommended					Operation not recommended					
	18.0	1.9	4.4						81.9	60.2	0.73	9.66	114.9	8.5
	24.0	3.9	9.0						83.7	61.1	0.73	9.38	115.7	8.9

Interpolation is permissible, extrapolation is not.

All entering air conditions are 80°F DB and 67°F WB in Cooling and 70°F DB in Heating.

All performance data is based upon the lower voltage of dual voltage units.

Operation below 60°F EWT requires optional insulated water/refrigerant circuit.

Operation below 40°F EWT is based upon 15% antifreeze solution.

See performance correction tables for operating conditions other than those listed above.

3/30/21

120 - Part Load - Performance Data

Capacity Data (2400 CFM)

EWT °F	WATER FLOW GPM	WPD		HEATING - EAT 70 °F					COOLING - EAT 80/67 °F					
		PSI	FT	HC	KW	HE	LAT	COP	TC	SC	S/T	KW	HR	EER
20	12.0	0.4	1.0	Operation not recommended					Operation not recommended					
	16.0	0.8	1.9	Operation not recommended					Operation not recommended					
	20.0	1.4	3.2	45.5	4.01	31.8	85.6	3.33						
30	12.0	0.4	1.0	Operation not recommended					Operation not recommended					
	16.0	0.8	1.8	53.2	4.05	39.4	88.5	3.85	95.4	58.8	0.62	3.31	106.7	28.8
	20.0	1.4	3.1	54.0	4.10	40.0	88.8	3.86	96.7	60.0	0.62	3.11	107.3	31.1
40	12.0	0.4	0.9	60.1	4.32	45.4	91.2	4.08	90.6	56.2	0.62	3.50	102.5	25.9
	16.0	0.8	1.8	61.1	4.38	46.1	91.6	4.09	93.5	58.3	0.62	3.40	105.1	27.5
	20.0	1.3	3.0	62.0	4.44	46.9	91.9	4.10	95.4	59.6	0.62	3.23	106.4	29.5
50	12.0	0.4	0.8	67.9	4.65	52.0	94.2	4.28	89.3	56.3	0.63	3.62	101.7	24.7
	16.0	0.7	1.7	69.0	4.71	52.9	94.6	4.29	91.7	57.7	0.63	3.48	103.5	26.3
	20.0	1.2	2.8	70.0	4.77	53.7	95.0	4.30	94.0	59.2	0.63	3.34	105.4	28.1
60	12.0	0.3	0.8	76.8	4.76	60.5	97.6	4.73	86.1	55.1	0.64	3.82	99.1	22.6
	16.0	0.7	1.6	78.0	4.82	61.5	98.1	4.74	88.4	56.5	0.64	3.67	100.9	24.1
	20.0	1.2	2.7	79.2	4.88	62.5	98.5	4.75	90.7	58.0	0.64	3.52	102.7	25.7
70	12.0	0.3	0.7	85.7	4.87	69.1	101.0	5.16	83.0	53.9	0.65	4.01	96.6	20.7
	16.0	0.7	1.5	87.0	4.93	70.2	101.6	5.17	85.1	55.3	0.65	3.85	98.3	22.1
	20.0	1.1	2.6	88.3	4.99	71.3	102.1	5.19	87.3	56.8	0.65	3.70	100.0	23.6
80	12.0	0.3	0.7	94.6	4.94	77.7	104.5	5.61	75.9	49.9	0.66	4.84	92.4	15.7
	16.0	0.6	1.5	96.0	5.00	79.0	105.1	5.63	78.1	51.3	0.66	4.61	93.8	16.9
	20.0	1.1	2.5	97.5	5.07	80.2	105.6	5.64	79.9	52.5	0.66	4.47	95.1	17.9
90	12.0	0.3	0.6	103.5	5.01	86.4	107.9	6.05	68.9	45.9	0.67	5.67	88.2	12.2
	16.0	0.6	1.4	105.1	5.08	87.8	108.5	6.07	71.1	47.3	0.67	5.40	89.5	13.1
	20.0	1.1	2.5	106.7	5.14	89.2	109.2	6.08	72.5	48.2	0.67	5.23	90.3	13.9
100	12.0	0.2	0.5	Operation not recommended					Operation not recommended					
	16.0	0.5	1.2						64.2	44.3	0.69	5.71	83.7	11.2
	20.0	1.0	2.3						65.2	44.6	0.69	5.53	84.0	11.8
110	12.0	0.2	0.4	Operation not recommended					Operation not recommended					
	16.0	0.5	1.2						56.6	40.4	0.71	5.99	77.1	9.5
	20.0	1.0	2.2						57.8	41.0	0.71	5.83	77.7	9.9
120	12.0	0.2	0.4	Operation not recommended					Operation not recommended					
	16.0	0.5	1.2						54.2	39.3	0.72	6.31	75.8	8.6
	20.0	0.9	2.2						55.4	39.9	0.72	6.13	76.3	9.0

Interpolation is permissible, extrapolation is not.

All entering air conditions are 80°F DB and 67°F WB in Cooling and 70°F DB in Heating.

All performance data is based upon the lower voltage of dual voltage units.

Operation below 60°F EWT requires optional insulated water/refrigerant circuit.

Operation below 40°F EWT is based upon 15% antifreeze solution.

See performance correction tables for operating conditions other than those listed above.

3/30/21

120 - Full Load - Performance Data

Capacity Data (3600 CFM)

EWT °F	WATER FLOW GPM	WPD		HEATING - EAT 70 °F					COOLING - EAT 80/67 °F					
		PSI	FT	HC	KW	HE	LAT	COP	TC	SC	S/T	KW	HR	EER
20	16.0	0.8	1.8	Operation not recommended					Operation not recommended					
	22.0	1.6	3.7											
	30.0	3.1	7.2	72.3	7.0	48.4	86.6	3.03						
30	16.0	0.8	1.8	Operation not recommended					Operation not recommended					
	22.0	1.5	3.5	84.9	7.30	60.0	89.8	3.41	142.3	96.0	0.68	5.83	162.1	24.4
	30.0	3.0	6.9	86.2	7.39	61.0	90.2	3.42	144.2	97.9	0.68	5.47	162.9	26.4
40	16.0	0.8	1.8	97.1	7.48	71.6	93.0	3.80	135.5	92.1	0.68	6.25	156.8	21.7
	22.0	1.4	3.2	100.3	7.72	74.0	93.8	3.81	139.6	95.3	0.68	6.09	160.4	22.9
	30.0	2.9	6.7	100.1	7.68	73.9	93.7	3.82	142.6	97.6	0.68	5.77	162.3	24.7
50	16.0	0.7	1.6	110.6	7.76	84.1	96.4	4.18	134.0	92.5	0.69	6.56	156.4	20.4
	22.0	1.3	3.0	112.0	7.85	85.3	96.8	4.19	137.0	94.5	0.69	6.35	158.7	21.6
	30.0	2.8	6.5	114.0	7.96	86.8	97.3	4.20	141.1	97.3	0.69	6.06	161.7	23.3
60	16.0	0.7	1.6	124.6	7.89	97.7	100.0	4.63	127.6	89.3	0.70	7.06	151.7	18.1
	22.0	1.3	3.0	126.2	7.98	99.0	100.5	4.64	130.5	91.3	0.70	6.83	153.8	19.1
	30.0	2.7	6.2	128.4	8.10	100.8	101.0	4.65	134.4	94.0	0.70	6.52	156.6	20.6
70	16.0	0.7	1.6	138.6	8.02	111.2	103.6	5.06	121.3	86.1	0.71	7.55	147.0	16.1
	22.0	1.2	2.8	140.4	8.11	112.8	104.1	5.07	124.0	88.1	0.71	7.30	148.9	17.0
	30.0	2.6	5.9	142.9	8.23	114.8	104.8	5.09	127.7	90.6	0.71	6.97	151.5	18.3
80	16.0	0.6	1.4	152.6	8.21	124.6	107.3	5.45	116.3	84.3	0.72	8.46	145.2	13.8
	22.0	1.2	2.8	154.8	8.31	126.5	107.8	5.46	119.4	86.5	0.72	8.06	147.0	14.8
	30.0	2.5	5.8	157.3	8.42	128.6	108.5	5.48	122.4	88.5	0.72	7.81	149.1	15.7
90	16.0	0.6	1.4	166.6	8.39	138.0	110.9	5.82	111.4	82.4	0.74	9.36	143.3	11.9
	22.0	1.2	2.8	169.2	8.51	140.2	111.5	5.83	114.9	85.0	0.74	8.93	145.3	12.9
	30.0	2.4	5.5	171.8	8.61	142.4	112.2	5.85	117.2	86.3	0.74	8.64	146.7	13.6
100	16.0	0.5	1.2	Operation not recommended					Operation not recommended					
	22.0	1.1	2.5						111.1	83.1	0.75	10.19	145.8	10.9
	30.0	2.3	5.3						112.8	83.8	0.74	9.86	146.4	11.4
110	16.0	0.5	1.2	Operation not recommended					Operation not recommended					
	22.0	1.1	2.5						106.2	80.1	0.75	11.39	145.0	9.3
	30.0	2.2	5.1						108.3	81.2	0.75	11.08	146.1	9.8
120	16.0	0.5	1.2	Operation not recommended					Operation not recommended					
	22.0	1.0	2.3						101.7	77.8	0.76	12.73	145.1	8.0
	30.0	2.1	4.9						103.9	79.0	0.76	12.36	146.1	8.4

Interpolation is permissible, extrapolation is not.

All entering air conditions are 80°F DB and 67°F WB in Cooling and 70°F DB in Heating.

All performance data is based upon the lower voltage of dual voltage units.

Operation below 60°F EWT requires optional insulated water/refrigerant circuit.

Operation below 40°F EWT is based upon 15% antifreeze solution.

See performance correction tables for operating conditions other than those listed above.

3/30/21

150 - Part Load - Performance Data

Capacity Data (2300 CFM)

EWT °F	WATER FLOW GPM	WPD		HEATING - EAT 70 °F					COOLING - EAT 80/67 °F					
		PSI	FT	HC	KW	HE	LAT	COP	TC	SC	S/T	KW	HR	EER
20	12.0	1.7	3.9	Operation not recommended					Operation not recommended					
	15.0	2.1	4.9											
	18.0	2.5	5.8	28.0	2.42	19.7	79.3	3.39						
30	12.0	1.6	3.7	Operation not recommended					Operation not recommended					
	15.0	2.0	4.6	36.7	3.18	25.8	82.8	3.38	85.4	62.9	0.74	3.25	96.5	26.3
	18.0	2.4	5.5	37.2	3.22	26.2	83.0	3.39	86.6	64.1	0.74	3.05	97.0	28.4
40	12.0	1.5	3.5	49.6	3.63	37.2	88.0	4.00	85.8	63.5	0.74	3.68	98.3	23.3
	15.0	1.9	4.4	57.2	3.95	43.8	91.0	4.24	84.7	63.0	0.74	3.44	96.5	24.7
	18.0	2.3	5.3	51.1	3.73	38.4	88.6	4.02	85.7	63.8	0.74	3.22	96.7	26.6
50	12.0	1.4	3.2	63.1	4.12	49.0	93.4	4.48	83.3	62.5	0.75	3.86	96.5	21.6
	15.0	1.8	4.2	64.0	4.18	49.8	93.8	4.49	84.0	63.0	0.75	3.63	96.4	23.2
	18.0	2.2	5.1	65.0	4.23	50.6	94.2	4.50	84.8	63.6	0.75	3.39	96.3	25.0
60	12.0	1.3	3.0	71.1	4.37	56.2	96.6	4.77	80.1	60.9	0.76	4.15	94.3	19.3
	15.0	1.7	3.9	72.2	4.42	57.1	97.1	4.79	81.2	61.7	0.76	3.89	94.5	20.9
	18.0	2.1	4.9	73.3	4.48	58.0	97.5	4.80	82.3	62.5	0.76	3.63	94.6	22.7
70	12.0	1.2	2.8	79.2	4.61	63.5	99.9	5.03	77.0	59.3	0.77	4.43	92.1	17.4
	15.0	1.6	3.7	80.4	4.67	64.5	100.4	5.05	78.4	60.3	0.77	4.15	92.5	18.9
	18.0	2.0	4.6	81.7	4.73	65.5	100.9	5.06	79.8	61.4	0.77	3.87	93.0	20.6
80	12.0	1.1	2.5	87.3	4.81	70.9	103.1	5.32	73.5	57.3	0.78	4.82	89.9	15.3
	15.0	1.5	3.5	88.7	4.87	72.0	103.7	5.33	75.3	58.7	0.78	4.59	90.9	16.4
	18.0	1.9	4.4	90.0	4.94	73.2	104.2	5.34	76.7	59.8	0.78	4.45	91.9	17.3
90	12.0	1.0	2.3	95.4	5.01	78.3	106.4	5.58	70.0	55.3	0.79	5.44	88.5	12.9
	15.0	1.4	3.2	96.9	5.08	79.5	107.0	5.59	72.2	57.0	0.79	5.19	89.9	13.9
	18.0	1.8	4.2	98.3	5.14	80.8	107.6	5.61	73.7	58.2	0.79	5.02	90.8	14.7
100	12.0	0.9	2.1	Operation not recommended					Operation not recommended					
	15.0	1.3	3.0						68.1	54.6	0.80	5.58	87.1	12.2
	18.0	1.7	3.9						69.1	55.1	0.80	5.40	87.5	12.8
110	12.0	0.8	1.8						Operation not recommended					
	15.0	1.2	2.8						63.3	51.1	0.81	5.94	83.5	10.6
	18.0	1.6	3.7						64.5	51.9	0.80	5.78	84.3	11.2
120	12.0	0.7	1.6						Operation not recommended					
	15.0	1.1	2.5						59.9	49.4	0.82	6.78	83.0	8.8
	18.0	1.5	3.5						61.2	50.1	0.82	6.58	83.6	9.3

Interpolation is permissible, extrapolation is not.

3/30/21

All entering air conditions are 80°F DB and 67°F WB in Cooling and 70°F DB in Heating.

All performance data is based upon the lower voltage of dual voltage units.

Operation below 60°F EWT requires optional insulated water/refrigerant circuit.

Operation below 40°F EWT is based upon 15% antifreeze solution.

See performance correction tables for operating conditions other than those listed above.

150 - Full Load - Performance Data

Capacity Data (4500 CFM)

EWT °F	WATER FLOW GPM	WPD		HEATING - EAT 70 °F					COOLING - EAT 80/67 °F					
		PSI	FT	HC	KW	HE	LAT	COP	TC	SC	S/T	KW	HR	EER
20	24.0	3.3	7.6	Operation not recommended					Operation not recommended					
	30.0	5.2	12.0	Operation not recommended					Operation not recommended					
	36.0	7.0	16.2	88.3	9.10	57.3	88.4	2.84						
30	24.0	3.2	7.4	Operation not recommended					Operation not recommended					
	30.0	5.1	11.8	95.1	9.16	63.8	87.6	3.04	171.8	111.1	0.65	6.46	193.9	26.6
	36.0	6.9	15.9	100.1	9.22	68.6	88.6	3.18	174.2	113.2	0.65	6.07	194.9	28.7
40	24.0	3.1	7.2	111.6	9.03	80.8	91.0	3.62	171.5	111.5	0.65	7.45	196.9	23.0
	30.0	5.0	11.6	114.5	9.22	83.0	91.6	3.64	170.0	110.8	0.65	6.96	193.7	24.4
	36.0	6.8	15.7	115.1	9.26	83.5	91.7	3.64	171.9	112.2	0.65	6.51	194.1	26.4
50	24.0	3.0	6.9	126.1	9.07	95.2	93.9	4.08	166.6	110.0	0.66	7.95	193.7	21.0
	30.0	4.9	11.3	128.1	9.18	96.7	94.3	4.09	168.1	110.6	0.66	7.45	193.5	22.6
	36.0	6.7	15.5	130.0	9.30	98.3	94.7	4.10	169.5	111.2	0.66	6.95	193.2	24.4
60	24.0	2.9	6.7	142.3	9.55	109.7	97.3	4.37	160.3	107.3	0.67	8.49	189.2	18.9
	30.0	4.8	11.1	144.5	9.67	111.5	97.7	4.38	162.4	108.5	0.67	8.07	189.9	20.1
	36.0	6.6	15.2	146.7	9.79	113.2	98.2	4.39	164.5	109.6	0.67	7.65	190.6	21.5
70	24.0	2.8	6.5	158.4	10.02	124.2	100.6	4.63	153.9	104.7	0.68	9.04	184.7	17.0
	30.0	4.7	10.9	160.9	10.15	126.2	101.1	4.64	156.7	106.4	0.68	8.69	186.4	18.0
	36.0	6.5	15.0	163.3	10.28	128.2	101.6	4.66	159.5	108.1	0.68	8.34	188.0	19.1
80	24.0	2.7	6.2	174.6	10.42	139.0	103.9	4.91	146.9	104.1	0.71	9.90	180.7	14.8
	30.0	4.6	10.6	177.3	10.56	141.3	104.5	4.92	150.5	106.6	0.71	9.44	182.8	15.9
	36.0	6.4	14.8	180.0	10.69	143.5	105.0	4.93	153.4	108.6	0.71	9.14	184.6	16.8
90	24.0	2.6	6.0	190.8	10.82	153.8	107.3	5.17	140.0	103.6	0.74	10.77	176.7	13.0
	30.0	4.5	10.4	193.7	10.97	156.3	107.9	5.18	144.4	106.8	0.74	10.27	179.4	14.1
	36.0	6.3	14.6	196.7	11.10	158.8	108.5	5.19	147.3	109.1	0.74	9.94	181.2	14.8
100	24.0	2.5	5.8	Operation not recommended					Operation not recommended					
	30.0	4.4	10.2						138.6	103.2	0.74	11.39	177.4	12.2
	36.0	6.2	14.3						140.7	104.1	0.74	11.02	178.3	12.8
110	24.0	2.4	5.5	Operation not recommended					Operation not recommended					
	30.0	4.3	9.9						131.3	97.5	0.74	12.44	173.8	10.6
	36.0	6.1	14.1						134.0	99.0	0.74	12.10	175.3	11.1
120	24.0	2.3	5.3	Operation not recommended					Operation not recommended					
	30.0	4.2	9.7						124.7	93.2	0.75	14.33	173.5	8.7
	36.0	6.0	13.9						127.3	94.6	0.74	13.91	174.8	9.2

Interpolation is permissible, extrapolation is not.

3/30/21

All entering air conditions are 80°F DB and 67°F WB in Cooling and 70°F DB in Heating.

All performance data is based upon the lower voltage of dual voltage units.

Operation below 60°F EWT requires optional insulated water/refrigerant circuit.

Operation below 40°F EWT is based upon 15% antifreeze solution.

See performance correction tables for operating conditions other than those listed above.

180 - Part Load - Performance Data

Capacity Data (2800 CFM)

EWT °F	WATER FLOW GPM	WPD		HEATING - EAT 70 °F					COOLING - EAT 80/67 °F					
		PSI	FT	HC	KW	HE	LAT	COP	TC	SC	S/T	KW	HR	EER
20	20.0	1.7	3.9	Operation not recommended					Operation not recommended					
	24.0	2.2	5.1	Operation not recommended					Operation not recommended					
	28.0	2.6	6.0	45.0	4.32	30.3	82.9	3.05	Operation not recommended					
30	20.0	1.6	3.7	Operation not recommended					Operation not recommended					
	24.0	2.1	4.9	53.4	4.79	37.0	85.6	3.27	100.0	69.6	0.70	3.71	112.7	27.0
	28.0	2.5	5.8	55.0	4.91	38.2	86.2	3.28	101.4	71.0	0.70	3.48	113.3	29.1
40	20.0	1.5	3.5	63.1	5.07	45.7	88.8	3.64	94.2	67.9	0.72	4.12	108.3	22.9
	24.0	2.0	4.6	66.4	5.26	48.4	89.9	3.70	97.3	69.8	0.72	4.00	111.0	24.3
	28.0	2.4	5.5	65.0	5.21	47.2	89.5	3.66	99.2	71.3	0.72	3.81	112.2	26.1
50	20.0	1.4	3.2	72.8	5.36	54.5	92.1	3.98	92.2	68.2	0.74	4.47	107.4	20.6
	24.0	1.9	4.4	73.9	5.43	55.3	92.4	3.99	94.6	69.9	0.74	4.30	109.3	22.0
	28.0	2.3	5.3	75.0	5.50	56.2	92.8	4.00	97.0	71.7	0.74	4.13	111.1	23.5
60	20.0	1.3	3.0	81.6	5.54	62.7	95.0	4.32	89.9	66.1	0.74	4.99	107.0	18.0
	24.0	1.8	4.2	82.9	5.61	63.8	95.4	4.33	92.3	67.9	0.74	4.80	108.7	19.2
	28.0	2.2	5.1	84.2	5.68	64.8	95.8	4.34	94.7	69.7	0.74	4.61	110.4	20.5
70	20.0	1.2	2.8	90.5	5.71	71.0	97.9	4.64	87.7	64.0	0.73	5.51	106.5	15.9
	24.0	1.7	3.9	91.9	5.79	72.2	98.4	4.66	90.0	65.8	0.73	5.30	108.1	17.0
	28.0	2.1	4.9	93.3	5.86	73.3	98.9	4.67	92.3	67.6	0.73	5.09	109.7	18.1
80	20.0	1.1	2.5	99.4	5.88	79.4	100.9	4.96	84.5	63.4	0.75	6.03	105.1	14.0
	24.0	1.6	3.7	101.0	5.96	80.7	101.4	4.97	87.0	65.2	0.75	5.76	106.6	15.1
	28.0	2.0	4.6	102.5	6.03	81.9	101.9	4.98	89.0	66.9	0.75	5.57	108.0	16.0
90	20.0	1.0	2.3	108.3	6.05	87.7	103.8	5.25	81.4	62.7	0.77	6.55	103.7	12.4
	24.0	1.5	3.5	110.0	6.12	89.1	104.4	5.26	84.0	64.6	0.77	6.25	105.3	13.4
	28.0	1.9	4.4	111.7	6.20	90.5	104.9	5.28	85.7	66.1	0.77	6.05	106.3	14.2
100	20.0	0.9	2.1	Operation not recommended					Operation not recommended					
	24.0	1.4	3.2						81.1	63.7	0.79	6.75	104.1	12.0
	28.0	1.8	4.2						82.3	64.2	0.78	6.54	104.6	12.6
110	20.0	0.8	1.8	Operation not recommended					Operation not recommended					
	24.0	1.3	3.0						77.4	61.4	0.79	7.22	102.0	10.7
	28.0	1.7	3.9						79.0	62.3	0.79	7.02	103.0	11.3
120	20.0	0.7	1.6	Operation not recommended					Operation not recommended					
	24.0	1.2	2.8						74.6	60.1	0.81	7.93	101.7	9.4
	28.0	1.6	3.7						76.2	61.0	0.80	7.70	102.5	9.9

Interpolation is permissible, extrapolation is not.

3/30/21

All entering air conditions are 80°F DB and 67°F WB in Cooling and 70°F DB in Heating.

All performance data is based upon the lower voltage of dual voltage units.

Operation below 60°F EWT requires optional insulated water/refrigerant circuit.

Operation below 40°F EWT is based upon 15% antifreeze solution.

See performance correction tables for operating conditions other than those listed above.

180 - Full Load - Performance Data

Capacity Data (5200 CFM)

EWT °F	WATER FLOW GPM	WPD		HEATING - EAT 70 °F					COOLING - EAT 80/67 °F					
		PSI	FT	HC	KW	HE	LAT	COP	TC	SC	S/T	KW	HR	EER
20	22.0	1.9	4.4	Operation not recommended					Operation not recommended					
	34.0	3.1	7.2											
	45.0	4.3	9.9	105.3	11.00	67.8	86.8	2.81						
30	22.0	1.8	4.2	Operation not recommended					Operation not recommended					
	34.0	3.0	6.9	122.4	11.50	83.2	89.8	3.12	195.8	129.4	0.66	9.19	227.1	21.3
	45.0	4.2	9.7	124.3	11.64	84.6	90.1	3.13	199.8	131.9	0.66	8.89	230.1	22.5
40	22.0	1.7	3.9	138.9	11.77	98.7	92.7	3.46	186.6	125.0	0.67	10.20	221.4	18.3
	34.0	2.9	6.7	144.4	11.95	103.7	93.7	3.54	192.1	128.8	0.67	9.77	225.4	19.7
	45.0	4.1	9.5	143.2	12.07	102.0	93.5	3.48	196.4	131.6	0.67	9.42	228.5	20.8
50	22.0	1.6	3.7	157.1	12.19	115.6	96.0	3.78	183.4	124.7	0.68	10.78	220.1	17.0
	34.0	2.8	6.5	159.7	12.35	117.5	96.4	3.79	188.4	128.1	0.68	10.35	223.7	18.2
	45.0	4.0	9.2	162.0	12.50	119.4	96.8	3.80	193.0	131.3	0.68	9.95	226.9	19.4
60	22.0	1.5	3.5	174.9	12.61	131.9	99.2	4.07	180.2	124.3	0.69	11.56	219.6	15.6
	34.0	2.7	6.2	177.8	12.78	134.2	99.7	4.08	185.1	127.8	0.69	11.10	223.0	16.7
	45.0	3.8	8.8	180.4	12.93	136.2	100.1	4.09	189.7	130.9	0.69	10.68	226.1	17.8
70	22.0	1.4	3.2	192.7	13.03	148.3	102.3	4.34	177.0	123.9	0.70	12.35	219.1	14.3
	34.0	2.6	6.0	195.8	13.20	150.8	102.9	4.35	181.8	127.4	0.70	11.85	222.3	15.3
	45.0	3.6	8.3	198.7	13.36	153.1	103.4	4.36	186.3	130.6	0.70	11.40	225.2	16.3
80	22.0	1.3	3.0	210.5	13.38	164.8	105.5	4.61	173.1	118.7	0.69	13.32	218.6	13.0
	34.0	2.5	5.8	213.8	13.55	167.6	106.1	4.62	178.2	122.2	0.69	12.71	221.6	14.0
	45.0	3.5	8.1	217.0	13.72	170.2	106.6	4.64	182.3	125.0	0.69	12.30	224.2	14.8
90	22.0	1.2	2.8	228.2	13.73	181.4	108.6	4.87	169.3	113.4	0.67	14.30	218.1	11.8
	34.0	2.4	5.5	231.8	13.91	184.3	109.3	4.88	174.6	117.0	0.67	13.64	221.2	12.8
	45.0	3.3	7.6	235.3	14.08	187.3	109.9	4.90	178.2	119.5	0.67	13.20	223.2	13.5
100	22.0	1.1	2.5	Operation not recommended					Operation not recommended					
	34.0	2.3	5.3						171.1	115.5	0.68	14.93	222.1	11.5
	45.0	3.2	7.4						173.8	116.5	0.67	14.45	223.1	12.0
110	22.0	1.0	2.3	Operation not recommended					Operation not recommended					
	34.0	2.2	5.1						165.9	111.8	0.67	16.14	221.0	10.3
	45.0	3.1	7.2						169.3	113.5	0.67	15.70	222.9	10.8
120	22.0	0.9	2.1	Operation not recommended					Operation not recommended					
	34.0	2.1	4.9						161.4	110.8	0.69	17.82	222.2	9.1
	45.0	3.0	6.9						164.9	112.4	0.68	17.30	223.9	9.5

Interpolation is permissible, extrapolation is not.

3/30/21

All entering air conditions are 80°F DB and 67°F WB in Cooling and 70°F DB in Heating.

All performance data is based upon the lower voltage of dual voltage units.

Operation below 60°F EWT requires optional insulated water/refrigerant circuit.

Operation below 40°F EWT is based upon 15% antifreeze solution.

See performance correction tables for operating conditions other than those listed above.

240 - Part Load - Performance Data

Capacity Data (5400 CFM)

EWT °F	WATER FLOW GPM	WPD		HEATING - EAT 70 °F					COOLING - EAT 80/67 °F					
		PSI	FT	HC	KW	HE	LAT	COP	TC	SC	S/T	KW	HR	EER
20	22.0	1.4	3.2	Operation not recommended					Operation not recommended					
	35.0	2.7	6.2											
	50.0	4.1	9.5	70.8	5.64	51.6	80.1	3.68						
30	22.0	1.4	3.2	Operation not recommended					Operation not recommended					
	35.0	2.7	6.2	80.8	6.12	59.9	81.8	3.86	154.2	107.3	0.70	5.13	171.7	30.0
	50.0	4.0	9.2	82.0	6.20	60.8	82.1	3.88	156.3	109.4	0.70	4.82	172.7	32.4
40	22.0	1.3	3.0	97.0	6.81	73.8	84.6	4.18	145.5	103.3	0.71	5.62	412.1	25.8
	35.0	2.6	6.0	98.5	6.90	75.0	84.9	4.19	150.1	106.4	0.71	5.47	168.8	27.4
	50.0	3.9	9.0	100.0	6.98	76.2	85.1	4.20	153.2	109.0	0.71	5.19	170.9	29.5
50	22.0	1.2	2.8	114.5	7.02	90.5	87.6	4.78	142.5	102.6	0.72	6.02	163.1	23.7
	35.0	2.5	5.8	116.1	7.10	91.9	87.9	4.79	146.0	105.4	0.72	5.81	165.8	25.1
	50.0	3.8	8.8	118.0	7.20	93.4	88.2	4.80	150.0	108.6	0.72	5.56	169.0	27.0
60	22.0	1.2	2.8	130.6	7.31	105.7	90.4	5.23	137.5	100.4	0.73	6.38	159.3	21.6
	35.0	2.5	5.8	132.5	7.40	107.2	90.7	5.25	140.9	103.1	0.73	6.15	161.9	22.9
	50.0	3.7	8.5	134.7	7.50	109.1	91.1	5.26	144.8	106.3	0.73	5.89	164.8	24.6
70	22.0	1.1	2.5	146.8	7.61	120.8	93.2	5.66	132.5	98.1	0.74	6.74	155.5	19.7
	35.0	2.4	5.5	148.9	7.70	122.6	93.5	5.67	135.8	100.8	0.74	6.50	157.9	20.9
	50.0	3.6	8.3	151.3	7.80	124.7	93.9	5.69	139.5	103.9	0.74	6.22	160.7	22.4
80	22.0	1.1	2.5	163.0	8.00	135.7	95.9	5.97	127.1	95.9	0.75	7.63	153.1	16.7
	35.0	2.3	5.3	165.4	8.10	137.8	96.4	5.98	130.6	98.7	0.76	7.27	155.4	18.0
	50.0	3.5	8.1	168.0	8.21	140.0	96.8	6.00	133.8	101.2	0.76	7.04	157.8	19.0
90	22.0	1.0	2.3	179.2	8.39	150.5	98.7	6.25	121.6	93.6	0.77	8.51	150.7	14.3
	35.0	2.2	5.1	181.9	8.51	152.9	99.2	6.27	125.4	96.6	0.77	8.12	153.2	15.4
	50.0	3.4	7.9	184.7	8.61	155.3	99.7	6.29	128.0	98.5	0.77	7.86	154.8	16.3
100	22.0	0.9	2.1	Operation not recommended					Operation not recommended					
	35.0	2.1	4.9						120.5	95.1	0.79	9.64	153.4	12.5
	50.0	3.3	7.6						122.4	95.9	0.78	9.33	154.2	13.1
110	22.0	0.8	1.8	Operation not recommended					Operation not recommended					
	35.0	2.0	4.6						114.4	91.8	0.80	11.10	152.2	10.3
	50.0	3.2	7.4						116.7	93.2	0.80	10.80	153.5	10.8
120	22.0	0.7	1.6	Operation not recommended					Operation not recommended					
	35.0	1.9	4.4						108.8	89.2	0.82	12.67	152.0	8.6
	50.0	3.1	7.2						111.1	90.5	0.81	12.30	153.1	9.0

Interpolation is permissible, extrapolation is not.

3/30/21

All entering air conditions are 80°F DB and 67°F WB in Cooling and 70°F DB in Heating.

All performance data is based upon the lower voltage of dual voltage units.

Operation below 60°F EWT requires optional insulated water/refrigerant circuit.

Operation below 40°F EWT is based upon 15% antifreeze solution.

See performance correction tables for operating conditions other than those listed above.

240 - Full Load - Performance Data

Capacity Data (7500 CFM)

EWT °F	WATER FLOW GPM	WPD		HEATING - EAT 70 °F					COOLING - EAT 80/67 °F					
		PSI	FT	HC	KW	HE	LAT	COP	TC	SC	S/T	KW	HR	EER
20	35.0	1.8	4.2	Operation not recommended					Operation not recommended					
	50.0	3.0	6.9	Operation not recommended					Operation not recommended					
	60.0	6.1	14.1	164.7	14.21	116.2	88.3	3.40						
30	35.0	1.8	4.2	Operation not recommended					Operation not recommended					
	50.0	3.0	6.9	176.8	13.60	130.4	89.8	3.81	299.6	217.5	0.73	10.39	335.1	28.8
	60.0	6.0	13.9	185.8	14.60	136.0	90.9	3.73	303.7	221.7	0.73	9.76	337.0	31.1
40	35.0	1.7	3.9	200.7	14.53	151.1	92.8	4.05	280.3	207.5	0.74	11.22	412.1	25.8
	50.0	2.9	6.7	199.8	14.31	151.0	92.7	4.09	289.5	213.3	0.74	10.90	326.7	26.6
	60.0	5.9	13.6	206.9	14.90	156.1	93.5	4.07	295.1	218.1	0.74	10.36	330.4	28.5
50	35.0	1.6	3.7	221.2	14.82	170.6	95.3	4.37	272.2	204.0	0.75	11.86	312.6	22.9
	50.0	2.8	6.5	225.3	15.05	173.9	95.8	4.39	279.3	209.2	0.75	11.41	318.3	24.5
	60.0	5.8	13.4	228.0	15.20	176.1	96.1	4.40	286.5	214.4	0.75	10.95	323.9	26.2
60	35.0	1.6	3.7	251.9	15.61	198.6	99.1	4.73	260.0	198.7	0.76	12.90	304.0	20.2
	50.0	2.7	6.2	256.5	15.85	202.4	99.7	4.74	266.9	204.1	0.76	12.40	309.2	21.5
	60.0	5.7	13.2	259.7	16.02	205.0	100.1	4.75	273.7	209.5	0.77	11.91	314.3	23.0
70	35.0	1.5	3.5	282.6	16.41	226.6	102.9	5.05	247.9	193.3	0.78	13.93	295.4	17.8
	50.0	2.6	6.0	287.8	16.66	231.0	103.5	5.06	254.4	199.0	0.78	13.40	300.1	19.0
	60.0	5.6	12.9	291.3	16.83	233.9	104.0	5.07	260.9	204.6	0.78	12.86	304.8	20.3
80	35.0	1.5	3.5	313.3	17.05	255.1	106.7	5.39	236.7	189.2	0.80	15.42	289.3	15.4
	50.0	2.5	5.8	318.6	17.29	259.6	107.3	5.40	243.6	195.0	0.80	14.70	293.7	16.6
	60.0	5.4	12.5	323.0	17.49	263.3	107.9	5.41	249.2	199.2	0.80	14.23	297.8	17.5
90	35.0	1.4	3.2	344.1	17.69	283.7	110.5	5.70	225.6	185.0	0.82	16.90	283.3	13.4
	50.0	2.4	5.5	349.4	17.92	288.2	111.1	5.71	232.8	191.0	0.82	16.12	287.7	14.4
	60.0	5.3	12.2	354.7	18.14	292.8	111.8	5.73	237.5	193.7	0.82	15.60	290.7	15.2
100	35.0	1.3	3.0	Operation not recommended					Operation not recommended					
	50.0	2.3	5.3	Operation not recommended					219.4	186.3	0.85	18.65	283.0	11.8
	60.0	5.2	12.0	Operation not recommended					222.8	187.9	0.84	18.05	284.3	12.3
110	35.0	1.2	2.8	Operation not recommended					Operation not recommended					
	50.0	2.2	5.1	Operation not recommended					203.8	179.4	0.88	21.07	275.7	9.7
	60.0	5.1	11.8	Operation not recommended					208.0	182.1	0.88	20.50	277.9	10.1
120	35.0	1.1	2.5	Operation not recommended					Operation not recommended					
	50.0	2.1	4.9	Operation not recommended					190.6	173.8	0.91	25.03	276.0	7.6
	60.0	5.0	11.6	Operation not recommended					194.7	176.4	0.91	24.30	277.6	8.0

Interpolation is permissible, extrapolation is not.

3/30/21

All entering air conditions are 80°F DB and 67°F WB in Cooling and 70°F DB in Heating.

All performance data is based upon the lower voltage of dual voltage units.

Operation below 60°F EWT requires optional insulated water/refrigerant circuit.

Operation below 40°F EWT is based upon 15% antifreeze solution.

See performance correction tables for operating conditions other than those listed above.

300 - Part Load - Performance Data

Capacity Data (6000 CFM)

EWT °F	WATER FLOW GPM	WPD		HEATING - EAT 70 °F					COOLING - EAT 80/67 °F					
		PSI	FT	HC	KW	HE	LAT	COP	TC	SC	S/T	KW	HR	EER
20	20.0	1.1	2.5	Operation not recommended					Operation not recommended					
	37.0	2.9	6.7											
	50.0	4.3	9.9	81.0	6.58	58.5	79.5	3.61						
30	20.0	1.0	2.3	Operation not recommended										
	37.0	2.8	6.5	84.2	6.64	61.6	80.0	3.72	200.2	145.3	0.73	5.3	218.1	38.0
	50.0	4.2	9.7	85.5	6.72	62.6	80.2	3.73	202.9	148.1	0.73	5.0	219.8	41.0
40	20.0	0.9	2.1	111.8	8.21	83.8	83.9	3.99	184.0	136.2	0.74	6.02	204.5	30.6
	37.0	2.7	6.2	113.5	8.32	85.1	84.2	4.00	190.3	140.3	0.74	5.83	210.2	32.7
	50.0	4.1	9.5	115.3	8.42	86.5	84.4	4.01	193.7	143.3	0.74	5.56	212.7	34.9
50	20.0	0.8	1.8	140.7	9.20	109.2	88.0	4.48	175.3	131.5	0.75	6.67	198.0	26.3
	37.0	2.6	6.0	143.1	9.34	111.3	88.4	4.49	180.5	135.4	0.75	6.38	202.3	28.3
	50.0	4.0	9.2	145.0	9.44	112.8	88.7	4.50	184.5	138.4	0.75	6.16	205.5	30.0
60	20.0	0.7	1.6	156.8	9.63	123.9	90.3	4.77	162.1	132.0	0.81	8.07	189.6	20.1
	37.0	2.5	5.8	159.5	9.77	126.2	90.7	4.78	166.9	136.1	0.82	7.72	193.2	21.6
	50.0	3.8	8.8	161.7	9.88	127.9	91.0	4.80	170.6	139.2	0.82	7.45	196.0	22.9
70	20.0	0.6	1.4	173.0	10.06	138.6	92.6	5.04	148.9	132.5	0.89	9.47	181.2	15.7
	37.0	2.4	5.4	176.0	10.21	141.2	93.1	5.05	153.3	136.8	0.89	9.06	184.2	16.9
	50.0	3.6	8.4	178.3	10.32	143.1	93.4	5.06	156.7	140.0	0.89	8.74	186.5	17.9
80	20.0	0.5	1.2	189.0	10.37	153.6	94.9	5.34	144.9	118.4	0.82	9.51	177.3	15.2
	37.0	2.3	5.3	192.1	10.51	156.2	95.4	5.35	149.3	122.5	0.82	9.07	180.3	16.5
	50.0	3.5	8.1	194.8	10.64	158.5	95.7	5.37	152.5	125.2	0.82	8.78	182.4	17.4
90	20.0	0.4	0.9	205.0	10.68	168.5	97.2	5.63	140.9	104.4	0.74	9.54	173.4	14.8
	37.0	2.2	5.1	208.1	10.82	171.2	97.6	5.64	145.3	108.2	0.74	9.10	176.4	16.0
	50.0	3.4	7.9	211.3	10.95	173.9	98.1	5.66	148.3	110.3	0.74	8.81	178.4	16.8
100	20.0	0.3	0.7	Operation not recommended					Operation not recommended					
	37.0	2.1	4.9						141.9	106.6	0.75	9.16	173.1	15.5
	50.0	3.3	7.6						144.1	107.5	0.75	8.87	174.3	16.2
110	20.0	0.2	0.5	Operation not recommended					Operation not recommended					
	37.0	2.0	4.6						137.0	103.2	0.75	9.17	168.3	14.9
	50.0	3.2	7.4						139.8	104.7	0.75	8.92	170.2	15.7
120	20.0	0.1	0.2	Operation not recommended					Operation not recommended					
	37.0	1.9	4.4						132.8	101.9	0.77	9.26	164.3	14.3
	50.0	3.1	7.2						135.6	103.4	0.76	8.99	166.3	15.1

Interpolation is permissible, extrapolation is not.

3/30/21

All entering air conditions are 80°F DB and 67°F WB in Cooling and 70°F DB in Heating.

All performance data is based upon the lower voltage of dual voltage units.

Operation below 60°F EWT requires optional insulated water/refrigerant circuit.

Operation below 40°F EWT is based upon 15% antifreeze solution.

See performance correction tables for operating conditions other than those listed above.

300 - Full Load - Performance Data

Capacity Data (9000 CFM)

EWT °F	WATER FLOW GPM	WPD		HEATING - EAT 70 °F					COOLING - EAT 80/67 °F					
		PSI	FT	HC	KW	HE	LAT	COP	TC	SC	S/T	KW	HR	EER
20	35.0	2.9	6.7	Operation not recommended					Operation not recommended					
	50.0	4.3	9.9	Operation not recommended					Operation not recommended					
	75.0	7.7	17.8	191.0	17.00	133.0	87.7	3.29	Operation not recommended					
30	35.0	2.8	6.5	Operation not recommended					Operation not recommended					
	50.0	4.2	9.7	222.6	17.68	162.3	90.9	3.69	361.3	244.3	0.7	12.7	404.6	28.4
	75.0	7.6	17.6	226.0	17.90	164.9	91.3	3.70	366.2	249.0	0.7	11.9	406.9	30.7
40	35.0	2.7	6.2	238.2	18.77	174.1	92.5	3.72	342.8	236.5	0.69	13.91	412.1	25.8
	50.0	4.1	9.5	255.2	20.64	184.8	94.3	3.62	352.0	241.9	0.69	13.64	398.6	25.8
	75.0	7.5	17.3	258.0	19.30	192.2	94.5	3.92	360.9	248.2	0.69	12.85	404.7	28.1
50	35.0	2.6	6.0	281.3	20.17	212.5	96.9	4.09	337.7	236.4	0.70	14.90	388.5	22.7
	50.0	4.0	9.2	283.8	20.32	214.5	97.2	4.09	342.8	239.6	0.70	14.57	392.5	23.5
	75.0	7.3	16.9	290.0	20.69	219.4	97.8	4.11	355.5	247.6	0.70	13.75	402.4	25.9
60	35.0	2.5	5.8	315.3	19.87	247.5	100.4	4.65	323.5	234.2	0.72	16.49	379.7	19.6
	50.0	3.9	9.0	318.0	20.01	249.8	100.7	4.66	328.3	237.5	0.72	16.13	383.4	20.4
	75.0	7.2	16.6	325.0	20.38	255.5	101.4	4.67	340.5	245.9	0.72	15.23	392.4	22.4
70	35.0	2.4	5.5	349.2	19.56	282.5	103.9	5.23	309.2	231.9	0.75	18.09	371.0	17.1
	50.0	3.8	8.8	352.3	19.70	285.1	104.2	5.24	313.9	235.4	0.75	17.69	374.2	17.7
	75.0	7.0	16.1	360.0	20.06	291.6	105.0	5.26	325.5	244.2	0.75	16.70	382.5	19.5
80	35.0	2.3	5.3	390.9	20.40	321.3	108.2	5.62	293.9	228.1	0.78	20.33	363.3	14.5
	50.0	3.7	8.5	395.8	20.61	325.5	108.7	5.63	300.7	233.3	0.78	19.40	366.8	15.5
	75.0	6.8	15.7	403.0	20.92	331.6	109.5	5.65	309.4	240.0	0.78	18.77	373.4	16.5
90	35.0	2.2	5.1	432.6	21.24	360.2	112.5	5.97	278.6	224.3	0.80	22.58	355.7	12.3
	50.0	3.6	8.3	439.3	21.52	365.9	113.2	5.98	287.4	231.1	0.80	21.53	360.9	13.3
	75.0	6.4	14.8	446.0	21.78	371.7	113.9	6.00	293.3	235.9	0.80	20.84	364.4	14.1
100	35.0	2.1	4.9	Operation not recommended					Operation not recommended					
	50.0	3.5	8.1	Operation not recommended					284.7	237.0	0.83	25.34	371.2	11.2
	75.0	6.2	14.3	Operation not recommended					289.1	239.0	0.83	24.52	372.7	11.8
110	35.0	2.0	4.6	Operation not recommended					Operation not recommended					
	50.0	3.4	7.9	Operation not recommended					279.1	238.5	0.85	28.99	378.0	9.6
	75.0	6.0	13.8	Operation not recommended					284.8	242.1	0.85	28.20	381.0	10.1
120	35.0	1.9	4.4	Operation not recommended					Operation not recommended					
	50.0	3.3	7.6	Operation not recommended					258.1	223.4	0.87	30.08	360.7	8.6
	75.0	5.8	13.4	Operation not recommended					263.6	226.7	0.86	29.20	363.2	9.0

Interpolation is permissible, extrapolation is not.

3/30/21

All entering air conditions are 80°F DB and 67°F WB in Cooling and 70°F DB in Heating.

All performance data is based upon the lower voltage of dual voltage units.

Operation below 60°F EWT requires optional insulated water/refrigerant circuit.

Operation below 40°F EWT is based upon 15% antifreeze solution.

See performance correction tables for operating conditions other than those listed above.

* System Design Not Recommended

360 - Part Load - Performance Data

Capacity Data (7500 CFM)

EWT °F	WATER FLOW GPM	WPD		HEATING - EAT 70 °F					COOLING - EAT 80/67 °F					
		PSI	FT	HC	KW	HE	LAT	COP	TC	SC	S/T	KW	HR	EER
20	25.0	1.6	3.7	Operation not recommended					Operation not recommended					
	35.0	2.4	5.5	Operation not recommended					Operation not recommended					
	45.0	3.1	7.2	82.0	7.54	56.3	78.1	3.19	Operation not recommended					
30	25.0	1.5	3.5	Operation not recommended					Operation not recommended					
	35.0	2.3	5.3	95.1	8.33	66.6	79.7	3.35	215.6	128.7	0.60	9.65	248.6	22.3
	45.0	3.0	6.9	98.0	8.54	68.9	80.1	3.36	218.6	131.2	0.60	9.06	249.5	24.1
40	25.0	1.4	3.2	130.0	10.24	95.0	84.0	3.72	198.8	119.3	0.60	10.24	233.8	19.4
	35.0	2.2	5.1	132.0	10.37	96.6	84.3	3.73	205.3	123.6	0.60	9.95	239.3	20.6
	45.0	2.9	6.7	134.0	10.50	98.2	84.5	3.74	209.3	126.2	0.60	9.46	241.6	22.1
50	25.0	1.3	3.0	164.9	12.15	123.4	88.4	3.98	190.0	115.9	0.61	10.67	226.4	17.8
	35.0	2.1	4.9	167.5	12.30	125.5	88.7	3.99	195.0	118.6	0.61	10.26	230.0	19.0
	45.0	2.8	6.5	170.0	12.46	127.5	89.0	4.00	200.0	121.2	0.61	9.85	233.6	20.3
60	25.0	1.2	2.8	192.9	13.79	145.9	91.8	4.10	179.4	115.4	0.64	11.33	218.1	15.8
	35.0	2.0	4.6	195.9	13.96	148.3	92.2	4.11	184.2	118.2	0.64	10.89	221.3	16.9
	45.0	2.7	6.2	198.9	14.14	150.7	92.6	4.12	188.9	121.0	0.64	10.46	224.6	18.1
70	25.0	1.1	2.5	221.0	15.42	168.3	95.3	4.20	168.9	114.8	0.68	11.98	209.8	14.1
	35.0	1.9	4.4	224.4	15.62	171.1	95.7	4.21	173.3	117.8	0.68	11.52	212.6	15.0
	45.0	2.6	6.0	227.8	15.82	173.8	96.1	4.22	177.8	120.9	0.68	11.06	215.5	16.1
80	25.0	1.0	2.3	249.0	16.88	191.4	98.7	4.32	167.1	111.9	0.67	14.17	215.4	11.8
	35.0	1.8	4.2	252.8	17.10	194.5	99.2	4.33	171.9	115.2	0.67	13.52	218.0	12.7
	45.0	2.5	5.8	256.7	17.31	197.6	99.7	4.35	175.9	118.1	0.67	13.08	220.5	13.4
90	25.0	0.9	2.1	277.0	18.33	214.5	102.2	4.43	165.3	109.0	0.66	16.36	221.1	10.1
	35.0	1.7	3.9	281.3	18.57	217.9	102.7	4.44	170.5	112.5	0.66	15.60	223.8	10.9
	45.0	2.4	5.5	285.6	18.80	221.5	103.3	4.45	174.0	115.3	0.66	15.10	225.5	11.5
100	25.0	0.8	1.8	Operation not recommended					Operation not recommended					
	35.0	1.6	3.7	Operation not recommended					168.6	115.5	0.69	17.54	228.4	9.6
	45.0	2.3	5.3	Operation not recommended					171.2	116.5	0.68	16.98	229.1	10.1
110	25.0	0.7	1.6	Operation not recommended					Operation not recommended					
	35.0	1.5	3.5	Operation not recommended					165.0	115.9	0.70	19.38	231.1	8.5
	45.0	2.2	5.1	Operation not recommended					168.3	117.7	0.70	18.85	232.6	8.9
120	25.0	0.6	1.4	Operation not recommended					Operation not recommended					
	35.0	1.4	3.2	Operation not recommended					162.1	110.2	0.68	21.12	234.1	7.7
	45.0	2.1	4.9	Operation not recommended					165.6	111.8	0.68	20.50	235.5	8.1

Interpolation is permissible, extrapolation is not.

3/30/21

All entering air conditions are 80°F DB and 67°F WB in Cooling and 70°F DB in Heating.

All performance data is based upon the lower voltage of dual voltage units.

Operation below 60°F EWT requires optional insulated water/refrigerant circuit.

Operation below 40°F EWT is based upon 15% antifreeze solution.

See performance correction tables for operating conditions other than those listed above.

360 - Full Load - Performance Data

Capacity Data (9900 CFM)

EWT °F	WATER FLOW GPM	WPD		HEATING - EAT 70 °F					COOLING - EAT 80/67 °F					
		PSI	FT	HC	KW	HE	LAT	COP	TC	SC	S/T	KW	HR	EER
20	50.0	3.5	8.1	Operation not recommended					Operation not recommended					
	70.0	6.2	14.3											
	90.0	8.8	20.3	223.3	22.00	148.2	88.9	2.97						
30	50.0	3.4	7.9	Operation not recommended					Operation not recommended					
	70.0	6.1	14.1	258.3	23.46	178.2	92.2	3.23	457.5	295.7	0.65	23.96	539.3	19.1
	90.0	8.7	20.1	262.2	23.75	181.2	92.5	3.24	463.8	301.5	0.65	22.50	540.6	20.6
40	50.0	3.3	7.6	292.1	24.35	209.0	95.3	3.52	421.0	273.6	0.65	24.70	505.3	17.0
	70.0	6.0	13.9	296.6	24.67	212.4	95.7	3.52	435.3	284.2	0.65	23.96	517.1	18.2
	90.0	8.6	19.9	301.1	24.98	215.9	96.2	3.53	443.2	290.2	0.65	22.80	520.9	19.4
50	50.0	3.2	7.4	329.8	25.55	242.6	98.8	3.78	401.4	264.9	0.66	25.02	486.8	16.0
	70.0	5.9	13.6	335.5	25.91	247.1	99.4	3.79	413.1	272.7	0.66	23.96	494.8	17.2
	90.0	8.5	19.6	340.0	26.20	250.6	99.8	3.80	422.5	278.9	0.66	23.10	501.3	18.3
60	50.0	3.1	7.2	362.1	27.22	269.3	101.9	3.90	371.2	253.5	0.68	25.08	456.7	14.8
	70.0	5.8	13.4	368.4	27.61	274.2	102.5	3.91	382.0	260.6	0.68	24.01	463.9	15.9
	90.0	8.4	19.4	373.3	27.92	278.1	102.9	3.92	390.7	266.2	0.68	23.15	469.7	16.9
70	50.0	3.0	6.9	394.5	28.90	295.9	104.9	4.00	340.9	242.1	0.71	25.13	426.7	13.6
	70.0	5.7	13.2	401.2	29.31	301.2	105.5	4.01	350.9	248.5	0.71	24.06	433.0	14.6
	90.0	8.3	19.2	406.7	29.64	305.5	106.0	4.02	358.9	253.6	0.71	23.20	438.0	15.5
80	50.0	2.9	6.7	426.8	30.44	322.9	107.9	4.11	335.7	233.4	0.70	29.30	435.7	11.5
	70.0	5.6	12.9	433.7	30.86	328.4	108.6	4.12	345.9	240.2	0.69	27.95	441.2	12.4
	90.0	8.2	18.9	440.0	31.22	333.5	109.2	4.13	353.3	244.6	0.69	27.05	445.6	13.1
90	50.0	2.8	6.5	459.1	31.98	350.0	110.9	4.21	330.4	224.7	0.68	33.47	444.6	9.9
	70.0	5.5	12.7	466.2	32.40	355.6	111.6	4.22	340.8	231.8	0.68	31.93	449.8	10.7
	90.0	8.1	18.7	473.3	32.80	361.4	112.3	4.23	347.8	235.5	0.68	30.90	453.2	11.3
100	50.0	2.7	6.2	Operation not recommended					Operation not recommended					
	70.0	5.4	12.5						337.1	224.4	0.67	36.25	460.8	9.3
	90.0	8.0	18.5						342.2	226.3	0.66	35.09	461.9	9.8
110	50.0	2.6	6.0						Operation not recommended					
	70.0	5.3	12.2						329.9	213.9	0.65	40.37	467.7	8.2
	90.0	7.9	18.2						336.7	217.0	0.64	39.27	470.7	8.6
120	50.0	2.5	5.8						Operation not recommended					
	70.0	5.2	12.0						324.2	204.4	0.63	46.04	481.2	7.0
	90.0	7.8	18.0						331.1	207.5	0.63	44.70	483.6	7.4

Interpolation is permissible, extrapolation is not.

3/30/21

All entering air conditions are 80°F DB and 67°F WB in Cooling and 70°F DB in Heating.

All performance data is based upon the lower voltage of dual voltage units.

Operation below 60°F EWT requires optional insulated water/refrigerant circuit.

Operation below 40°F EWT is based upon 15% antifreeze solution.

See performance correction tables for operating conditions other than those listed above.

084 - Part Load Horizontal - Performance Data

Capacity Data (1700 CFM)

EWT °F	WATER FLOW GPM	WPD		HEATING - EAT 70 °F					COOLING - EAT 80/67 °F					
		PSI	FT	HC	KW	HE	LAT	COP	TC	SC	S/T	KW	HR	EER
20	8.0	1.6	3.7	Operation not recommended					Operation not recommended					
	10.0	1.8	4.2	Operation not recommended					Operation not recommended					
	16.0	3.6	8.3	37.8	3.3	26.5	88.0	3.34						
30	8.0	1.5	3.5	Operation not recommended					Operation not recommended					
	10.0	1.7	3.9	40.3	3.47	28.4	89.3	3.40	71.6	42.7	0.60	2.03	78.6	35.2
	16.0	3.5	8.1	41.5	3.56	29.4	90.0	3.42	72.6	43.6	0.60	1.91	79.1	38.0
40	8.0	1.4	3.2	46.3	3.49	34.4	92.5	3.89	66.7	40.0	0.60	2.13	74.0	31.4
	10.0	1.6	3.7	47.8	3.48	35.9	93.3	4.03	68.5	41.3	0.60	2.09	75.6	32.8
	16.0	3.4	7.9	47.8	3.58	35.5	93.3	3.91	70.3	42.5	0.60	1.97	77.0	35.8
50	8.0	1.3	3.0	52.4	3.51	40.4	95.7	4.38	64.5	39.3	0.61	2.19	72.0	29.5
	10.0	1.5	3.5	52.8	3.53	40.7	95.9	4.39	65.4	39.8	0.61	2.15	72.7	30.5
	16.0	3.3	7.6	54.0	3.60	41.7	96.6	4.40	67.9	41.4	0.61	2.02	74.8	33.6
60	8.0	1.2	2.8	58.2	3.55	46.1	98.8	4.80	61.4	38.3	0.62	2.58	70.2	23.8
	10.0	1.4	3.2	58.7	3.57	46.5	99.0	4.81	62.2	38.8	0.62	2.53	70.9	24.6
	16.0	3.2	7.4	60.0	3.64	47.6	99.7	4.83	64.7	40.4	0.62	2.38	72.8	27.2
70	8.0	1.1	2.5	64.0	3.60	51.7	101.9	5.22	58.3	37.3	0.64	2.97	68.5	19.7
	10.0	1.3	3.0	64.5	3.62	52.2	102.1	5.22	59.1	37.8	0.64	2.91	69.0	20.3
	16.0	3.1	7.2	66.0	3.69	53.4	102.9	5.24	61.4	39.3	0.64	2.74	70.7	22.4
80	8.0	1.0	2.3	68.9	3.66	56.4	104.5	5.52	55.3	36.2	0.65	3.56	67.4	15.5
	10.0	1.2	2.8	69.7	3.70	57.1	104.9	5.53	56.5	37.0	0.65	3.39	68.1	16.6
	16.0	3.0	6.9	71.1	3.76	58.2	105.6	5.55	58.2	38.1	0.65	3.29	69.4	17.7
90	8.0	0.9	2.1	73.8	3.72	61.1	107.1	5.81	52.3	35.0	0.67	4.15	66.4	12.6
	10.0	1.0	2.3	75.0	3.77	62.1	107.7	5.82	53.9	36.1	0.67	3.96	67.4	13.6
	16.0	2.9	6.7	76.1	3.82	63.1	108.3	5.84	55.0	36.9	0.67	3.83	68.1	14.4
100	8.0	0.8	1.8	Operation not recommended					Operation not recommended					
	10.0	0.9	2.1						51.0	33.5	0.66	4.23	65.4	12.0
	16.0	2.8	6.5						51.8	33.8	0.65	4.10	65.7	12.6
110	8.0	0.7	1.6	Operation not recommended					Operation not recommended					
	10.0	0.8	1.8						47.5	30.2	0.63	4.48	62.8	10.6
	16.0	2.7	6.2						48.5	30.6	0.63	4.36	63.4	11.1
120	8.0	0.6	0.0	Operation not recommended					Operation not recommended					
	10.0	0.7	1.6						43.0	27.3	0.64	4.43	58.1	9.7
	16.0	2.6	6.0						43.9	27.7	0.63	4.30	58.6	10.2

Interpolation is permissible, extrapolation is not.

3/30/21

All entering air conditions are 80°F DB and 67°F WB in Cooling and 70°F DB in Heating.

All performance data is based upon the lower voltage of dual voltage units.

Operation below 60°F EWT requires optional insulated water/refrigerant circuit.

Operation below 40°F EWT is based upon 15% antifreeze solution.

See performance correction tables for operating conditions other than those listed above.

084 - Full Load Horizontal - Performance Data

Capacity Data (2500 CFM)

EWT °F	WATER FLOW GPM	WPD		HEATING - EAT 70 °F					COOLING - EAT 80/67 °F					
		PSI	FT	HC	KW	HE	LAT	COP	TC	SC	S/T	KW	HR	EER
20	10.0	1.8	4.2	Operation not recommended					Operation not recommended					
	16.0	3.6	8.3	Operation not recommended					Operation not recommended					
	22.0	7.8	18.0	54.0	5.1	36.8	88.0	3.13	Operation not recommended					
30	10.0	1.7	3.9	Operation not recommended					Operation not recommended					
	16.0	3.5	8.1	62.3	5.20	44.5	91.1	3.51	91.8	64.8	0.71	3.64	104.3	25.2
	22.0	7.1	16.3	63.2	5.26	45.3	91.4	3.52	93.1	66.1	0.71	3.42	104.8	27.2
40	10.0	1.6	3.7	70.7	5.30	52.6	94.2	3.90	91.0	61.5	0.68	4.08	104.9	22.3
	16.0	3.4	7.9	73.0	5.30	54.9	95.0	4.04	93.9	63.5	0.68	3.90	107.2	24.1
	22.0	6.5	15.0	72.9	5.44	54.3	95.0	3.92	95.8	65.4	0.68	3.77	108.7	25.4
50	10.0	1.5	3.5	80.0	5.48	61.3	97.6	4.28	93.6	61.8	0.66	4.46	108.8	21.0
	16.0	3.3	7.6	81.3	5.55	62.3	98.1	4.29	96.0	63.4	0.66	4.29	110.7	22.4
	22.0	6.0	14.0	82.5	5.62	63.3	98.6	4.30	98.5	65.0	0.66	4.12	112.6	23.9
60	10.0	1.4	3.2	89.8	5.90	69.6	101.2	4.46	90.1	60.3	0.67	4.79	106.4	18.8
	16.0	3.2	7.4	91.2	5.97	70.8	101.8	4.47	92.4	61.9	0.67	4.60	108.1	20.1
	22.0	5.7	13.2	92.6	6.05	71.9	102.3	4.48	94.8	63.5	0.67	4.42	109.9	21.4
70	10.0	1.3	3.0	99.5	6.32	78.0	104.9	4.62	86.5	58.9	0.68	5.11	104.0	16.9
	16.0	3.1	7.2	101.1	6.40	79.2	105.4	4.63	88.8	60.4	0.68	4.92	105.6	18.1
	22.0	5.3	12.3	102.6	6.48	80.5	106.0	4.64	91.1	61.9	0.68	4.72	107.2	19.3
80	10.0	1.2	2.8	109.9	6.43	88.0	108.7	5.01	83.0	56.9	0.68	5.74	102.6	14.5
	16.0	3.0	6.9	111.6	6.51	89.4	109.3	5.02	85.4	58.5	0.68	5.47	104.1	15.6
	22.0	5.1	11.8	113.3	6.60	90.8	110.0	5.04	87.4	59.9	0.68	5.30	105.5	16.5
90	10.0	1.0	2.3	120.3	6.54	98.0	112.5	5.39	79.5	54.9	0.69	6.36	101.2	12.5
	16.0	2.9	6.7	122.1	6.63	99.5	113.2	5.40	82.0	56.6	0.69	6.07	102.7	13.5
	22.0	4.9	11.4	124.0	6.71	101.1	113.9	5.42	83.7	57.8	0.69	5.87	103.7	14.3
100	10.0	0.9	2.1	Operation not recommended					Operation not recommended					
	16.0	2.8	6.5	Operation not recommended					77.2	52.9	0.69	6.96	101.0	11.1
	22.0	4.8	11.1	Operation not recommended					78.4	53.4	0.68	6.74	101.4	11.6
110	10.0	0.8	1.8	Operation not recommended					Operation not recommended					
	16.0	2.7	6.2	Operation not recommended					71.6	49.9	0.70	7.82	98.3	9.2
	22.0	4.7	10.7	Operation not recommended					73.1	50.7	0.69	7.61	99.0	9.6
120	10.0	0.7	1.6	Operation not recommended					Operation not recommended					
	16.0	2.6	6.0	Operation not recommended					67.4	47.7	0.71	8.86	97.6	7.6
	22.0	4.5	10.4	Operation not recommended					68.8	48.4	0.70	8.60	98.1	8.0

Interpolation is permissible, extrapolation is not.

All entering air conditions are 80°F DB and 67°F WB in Cooling and 70°F DB in Heating.

All performance data is based upon the lower voltage of dual voltage units.

Operation below 60°F EWT requires optional insulated water/refrigerant circuit.

Operation below 40°F EWT is based upon 15% antifreeze solution.

See performance correction tables for operating conditions other than those listed above.

3/30/21

096 - Part Load Horizontal - Performance Data

Capacity Data (1900 CFM)

EWT °F	WATER FLOW GPM	WPD		HEATING - EAT 70 °F					COOLING - EAT 80/67 °F					
		PSI	FT	HC	KW	HE	LAT	COP	TC	SC	S/T	KW	HR	EER
20	12.0	1.5	3.5	Operation not recommended					Operation not recommended					
	16.0	2.4	5.5	Operation not recommended					Operation not recommended					
	18.0	2.9	6.7	35.6	3.8	22.5	85.3	2.7						
30	12.0	1.4	3.2	Operation not recommended					Operation not recommended					
	16.0	2.3	5.3	42.4	3.84	29.3	88.7	3.24	79.7	51.5	0.65	2.11	86.9	37.8
	18.0	2.8	6.5	43.1	3.89	29.8	89.0	3.25	80.8	52.5	0.65	1.98	87.6	40.8
40	12.0	1.3	3.0	50.0	3.89	36.7	92.4	3.77	74.2	49.0	0.66	2.40	82.4	30.9
	16.0	2.2	5.1	53.4	3.95	40.0	94.0	3.97	77.0	50.6	0.66	2.31	84.9	33.3
	18.0	2.7	6.2	51.5	3.99	37.9	93.1	3.79	78.2	51.6	0.66	2.22	85.7	35.3
50	12.0	1.2	2.8	58.2	3.99	44.6	96.4	4.28	71.7	48.1	0.67	2.65	80.8	27.0
	16.0	2.1	4.9	59.4	4.06	45.6	96.9	4.29	74.2	49.7	0.67	2.52	82.8	29.5
	18.0	2.6	6.0	60.0	4.09	46.0	97.2	4.30	75.5	50.6	0.67	2.45	83.9	30.8
60	12.0	1.1	2.5	65.2	4.10	51.2	99.8	4.66	67.7	46.3	0.68	2.97	77.8	22.8
	16.0	2.0	4.6	66.5	4.17	52.3	100.4	4.68	70.1	47.9	0.68	2.82	79.7	24.9
	18.0	2.5	5.8	67.2	4.21	52.9	100.7	4.68	71.3	48.7	0.68	2.74	80.6	26.0
70	12.0	1.0	2.3	72.2	4.21	57.8	103.2	5.02	63.7	44.6	0.70	3.28	74.8	19.4
	16.0	1.9	4.4	73.7	4.28	59.0	103.9	5.04	65.9	46.1	0.70	3.11	76.5	21.2
	18.0	2.4	5.5	74.4	4.32	59.7	104.3	5.05	67.0	46.9	0.70	3.03	77.3	22.1
80	12.0	0.9	2.1	80.0	4.35	65.2	107.0	5.39	61.1	42.8	0.70	3.91	74.5	15.7
	16.0	1.8	4.2	81.4	4.41	66.4	107.7	5.41	63.2	44.2	0.70	3.73	75.9	17.0
	18.0	2.3	5.3	82.5	4.46	67.2	108.2	5.42	64.4	45.0	0.70	3.61	76.7	17.9
90	12.0	0.8	1.8	87.8	4.49	72.5	110.8	5.74	58.6	41.0	0.70	4.53	74.1	12.9
	16.0	1.7	3.9	89.2	4.54	73.7	111.5	5.75	60.5	42.3	0.70	4.32	75.2	14.0
	18.0	2.2	5.1	90.5	4.60	74.8	112.1	5.77	61.7	43.2	0.70	4.18	76.0	14.8
100	12.0	0.7	1.6	Operation not recommended					Operation not recommended					
	16.0	1.6	3.7						57.5	40.8	0.71	4.75	73.7	12.1
	18.0	2.1	4.9						58.4	41.1	0.70	4.60	74.0	12.7
110	12.0	0.6	1.4	Operation not recommended					Operation not recommended					
	16.0	1.5	3.5						53.9	38.5	0.71	5.15	71.5	10.5
	18.0	2.0	4.6						55.0	39.1	0.71	5.01	72.1	11.0
120	12.0	0.5	1.2	Operation not recommended					Operation not recommended					
	16.0	1.4	3.2						50.6	37.2	0.73	5.89	70.7	8.6
	18.0	1.9	4.4						51.7	37.7	0.73	5.72	71.2	9.0

Interpolation is permissible, extrapolation is not.

3/30/21

All entering air conditions are 80°F DB and 67°F WB in Cooling and 70°F DB in Heating.

All performance data is based upon the lower voltage of dual voltage units.

Operation below 60°F EWT requires optional insulated water/refrigerant circuit.

Operation below 40°F EWT is based upon 15% antifreeze solution.

See performance correction tables for operating conditions other than those listed above.

096 - Full Load Horizontal - Performance Data

Capacity Data (2800 CFM)

EWT °F	WATER FLOW GPM	WPD		HEATING - EAT 70 °F					COOLING - EAT 80/67 °F					
		PSI	FT	HC	KW	HE	LAT	COP	TC	SC	S/T	KW	HR	EER
20	12.0	1.5	3.5	Operation not recommended					Operation not recommended					
	18.0	2.9	6.7											
	24.0	5.0	11.6	61.5	5.40	43.1	88.3	3.34						
30	12.0	1.4	3.2	Operation not recommended					Operation not recommended					
	18.0	2.8	6.5	70.5	5.73	51.0	91.3	3.61	101.4	70.6	0.70	4.23	115.8	24.0
	24.0	4.9	11.3	71.6	5.80	51.8	91.7	3.62	102.8	72.0	0.70	3.97	116.3	25.9
40	12.0	1.3	3.0	79.8	5.85	59.9	94.4	4.00	99.5	68.7	0.69	4.60	115.2	21.6
	18.0	2.7	6.2	81.2	5.72	61.7	94.8	4.16	102.7	70.1	0.68	4.47	118.0	23.0
	24.0	4.8	11.1	82.3	6.00	61.8	95.2	4.02	104.8	71.7	0.68	4.25	119.3	24.6
50	12.0	1.2	2.8	90.2	6.05	69.6	97.8	4.37	101.4	67.9	0.67	4.91	118.1	20.7
	18.0	2.6	6.0	91.6	6.12	70.7	98.3	4.39	104.0	69.7	0.67	4.72	120.1	22.0
	24.0	4.6	10.5	93.0	6.20	71.8	98.8	4.40	106.7	71.5	0.67	4.53	122.2	23.6
60	12.0	1.1	2.5	102.8	6.49	80.7	102.0	4.64	98.0	66.1	0.67	5.36	116.3	18.3
	18.0	2.5	5.8	104.4	6.58	82.0	102.5	4.65	100.6	67.9	0.67	5.15	118.1	19.5
	24.0	4.5	10.4	106.0	6.66	83.3	103.1	4.66	103.2	69.6	0.67	4.95	120.0	20.9
70	12.0	1.0	2.3	115.4	6.94	91.7	106.2	4.87	94.6	64.3	0.68	5.81	114.4	16.3
	18.0	2.4	5.5	117.2	7.03	93.2	106.8	4.89	97.1	66.0	0.68	5.58	116.2	17.4
	24.0	4.4	10.2	119.0	7.12	94.7	107.4	4.90	99.6	67.7	0.68	5.36	117.9	18.6
80	12.0	0.9	2.1	124.1	7.22	99.4	109.0	5.04	90.5	62.4	0.69	6.42	112.4	14.1
	18.0	2.3	5.3	126.0	7.31	101.0	109.7	5.05	93.1	64.2	0.69	6.13	114.0	15.2
	24.0	4.3	9.9	127.9	7.40	102.7	110.3	5.07	95.3	65.7	0.69	5.93	115.5	16.1
90	12.0	0.8	1.8	132.7	7.49	107.1	111.9	5.19	86.4	60.4	0.70	7.04	110.4	12.3
	18.0	2.2	5.1	134.7	7.59	108.9	112.6	5.21	89.1	62.4	0.70	6.72	112.0	13.3
	24.0	4.2	9.7	136.8	7.68	110.6	113.2	5.22	90.9	63.6	0.70	6.50	113.1	14.0
100	12.0	0.7	1.6	Operation not recommended					Operation not recommended					
	18.0	2.1	4.9						86.3	61.3	0.71	7.56	112.1	11.4
	24.0	4.1	9.5						87.7	61.8	0.70	7.32	112.6	12.0
110	12.0	0.6	1.4	Operation not recommended					Operation not recommended					
	18.0	2.0	4.6						82.7	59.0	0.71	8.37	111.3	9.9
	24.0	4.0	9.2						84.4	59.9	0.71	8.14	112.2	10.4
120	12.0	0.5	1.2	Operation not recommended					Operation not recommended					
	18.0	1.9	4.4						79.5	58.4	0.73	9.70	112.6	8.2
	24.0	3.9	9.0						81.2	59.3	0.73	9.42	113.3	8.6

Interpolation is permissible, extrapolation is not.

3/30/21

All entering air conditions are 80°F DB and 67°F WB in Cooling and 70°F DB in Heating.

All performance data is based upon the lower voltage of dual voltage units.

Operation below 60°F EWT requires optional insulated water/refrigerant circuit.

Operation below 40°F EWT is based upon 15% antifreeze solution.

See performance correction tables for operating conditions other than those listed above.

120 - Part Load Horizontal - Performance Data

Capacity Data (2400 CFM)

EWT °F	WATER FLOW GPM	WPD		HEATING - EAT 70 °F					COOLING - EAT 80/67 °F					
		PSI	FT	HC	KW	HE	LAT	COP	TC	SC	S/T	KW	HR	EER
20	12.0	0.4	1.0	Operation not recommended					Operation not recommended					
	16.0	0.8	1.9											
	20.0	1.4	3.2	44.8	4.04	31.0	85.3	3.25						
30	12.0	0.4	1.0	Operation not recommended					Operation not recommended					
	16.0	0.8	1.8	52.6	4.06	38.7	88.3	3.80	94.1	58.0	0.62	3.34	105.5	28.1
	20.0	1.4	3.1	53.4	4.11	39.4	88.6	3.81	95.4	59.1	0.62	3.14	106.1	30.4
40	12.0	0.4	0.9	59.8	4.33	45.1	91.1	4.05	89.1	55.2	0.62	3.52	101.1	25.3
	16.0	0.8	1.8	60.8	4.39	45.8	91.4	4.06	92.0	57.3	0.62	3.42	103.6	26.9
	20.0	1.3	3.0	61.7	4.44	46.6	91.8	4.07	93.8	58.6	0.62	3.25	104.8	28.8
50	12.0	0.4	0.8	67.9	4.65	52.0	94.2	4.28	87.5	55.1	0.63	3.64	99.9	24.0
	16.0	0.7	1.7	69.0	4.71	52.9	94.6	4.29	89.8	56.6	0.63	3.50	101.8	25.7
	20.0	1.2	2.8	70.0	4.77	53.7	95.0	4.30	92.1	58.0	0.63	3.36	103.6	27.4
60	12.0	0.3	0.8	75.9	4.76	59.7	97.3	4.67	84.4	54.0	0.64	3.83	97.5	22.0
	16.0	0.7	1.6	77.1	4.82	60.6	97.7	4.68	86.6	55.4	0.64	3.68	99.2	23.5
	20.0	1.2	2.7	78.3	4.89	61.6	98.2	4.69	88.9	56.8	0.64	3.54	100.9	25.1
70	12.0	0.3	0.7	83.9	4.88	67.3	100.4	5.04	81.3	52.9	0.65	4.02	95.0	20.2
	16.0	0.7	1.5	85.2	4.94	68.4	100.9	5.06	83.5	54.2	0.65	3.86	96.6	21.6
	20.0	1.1	2.6	86.5	5.00	69.4	101.4	5.07	85.6	55.6	0.65	3.71	98.3	23.1
80	12.0	0.3	0.7	92.7	4.95	75.8	103.8	5.49	74.4	49.1	0.66	4.86	91.0	15.3
	16.0	0.6	1.5	94.1	5.01	77.0	104.3	5.50	76.6	50.5	0.66	4.63	92.4	16.5
	20.0	1.1	2.5	95.6	5.08	78.2	104.9	5.52	78.4	51.6	0.66	4.49	93.7	17.5
90	12.0	0.3	0.6	101.5	5.02	84.3	107.1	5.92	67.5	45.3	0.67	5.70	87.0	11.9
	16.0	0.6	1.4	103.0	5.09	85.7	107.7	5.94	69.7	46.7	0.67	5.44	88.2	12.8
	20.0	1.1	2.5	104.6	5.15	87.0	108.4	5.95	71.1	47.6	0.67	5.26	89.0	13.5
100	12.0	0.2	0.5	Operation not recommended					Operation not recommended					
	16.0	0.5	1.2						63.0	43.6	0.69	5.74	82.6	11.0
	20.0	1.0	2.3						64.0	44.0	0.69	5.56	82.9	11.5
110	12.0	0.2	0.4	Operation not recommended					Operation not recommended					
	16.0	0.5	1.2						55.7	39.7	0.71	6.01	76.2	9.3
	20.0	1.0	2.2						56.8	40.3	0.71	5.85	76.8	9.7
120	12.0	0.2	0.4	Operation not recommended					Operation not recommended					
	16.0	0.5	1.2						53.6	38.9	0.72	6.32	75.2	8.5
	20.0	0.9	2.2						54.8	39.5	0.72	6.14	75.7	8.9

Interpolation is permissible, extrapolation is not.

All entering air conditions are 80°F DB and 67°F WB in Cooling and 70°F DB in Heating.

All performance data is based upon the lower voltage of dual voltage units.

Operation below 60°F EWT requires optional insulated water/refrigerant circuit.

Operation below 40°F EWT is based upon 15% antifreeze solution.

See performance correction tables for operating conditions other than those listed above.

3/30/21

120 - Full Load Horizontal - Performance Data

Capacity Data (3600 CFM)

EWT °F	WATER FLOW GPM	WPD		HEATING - EAT 70 °F					COOLING - EAT 80/67 °F					
		PSI	FT	HC	KW	HE	LAT	COP	TC	SC	S/T	KW	HR	EER
20	16.0	0.8	1.8	Operation not recommended					Operation not recommended					
	22.0	1.6	3.7	Operation not recommended					Operation not recommended					
	30.0	3.1	7.2	72.0	7.01	48.1	86.5	3.01	Operation not recommended					
30	16.0	0.8	1.8	Operation not recommended					Operation not recommended					
	22.0	1.5	3.5	84.5	7.32	59.5	89.7	3.38	140.2	94.8	0.68	5.85	160.1	24.0
	30.0	3.0	6.9	85.8	7.41	60.5	90.1	3.39	142.1	96.6	0.68	5.49	160.8	25.9
40	16.0	0.8	1.8	96.9	7.49	71.3	92.9	3.79	133.2	90.6	0.68	6.27	154.6	21.3
	22.0	1.4	3.2	101.2	7.73	74.8	94.0	3.84	137.3	93.7	0.68	6.11	158.1	22.5
	30.0	2.9	6.7	99.9	7.69	73.7	93.7	3.81	140.2	96.0	0.68	5.79	159.9	24.2
50	16.0	0.7	1.6	110.6	7.76	84.1	96.4	4.18	131.4	90.7	0.69	6.59	153.9	19.9
	22.0	1.3	3.0	112.0	7.85	85.3	96.8	4.19	134.3	92.7	0.69	6.37	156.1	21.1
	30.0	2.8	6.5	114.0	7.96	86.8	97.3	4.20	138.3	95.4	0.69	6.08	159.0	22.7
60	16.0	0.7	1.6	123.3	7.88	96.4	99.7	4.59	124.5	87.1	0.70	7.07	148.6	17.6
	22.0	1.3	3.0	125.0	7.97	97.8	100.1	4.60	127.3	89.0	0.70	6.84	150.6	18.6
	30.0	2.7	6.2	127.2	8.09	99.6	100.7	4.61	131.1	91.7	0.70	6.53	153.3	20.1
70	16.0	0.7	1.6	136.1	8.00	108.8	103.0	4.98	117.6	83.5	0.71	7.56	143.4	15.6
	22.0	1.2	2.8	137.9	8.09	110.3	103.5	4.99	120.3	85.4	0.71	7.31	145.2	16.4
	30.0	2.6	5.9	140.3	8.21	112.3	104.1	5.01	123.8	87.9	0.71	6.98	147.6	17.7
80	16.0	0.6	1.4	149.9	8.21	121.9	106.5	5.35	113.4	82.1	0.72	8.47	142.3	13.4
	22.0	1.2	2.8	152.0	8.31	123.7	107.1	5.36	116.4	84.4	0.72	8.08	144.0	14.4
	30.0	2.5	5.8	154.5	8.42	125.8	107.7	5.38	119.4	86.5	0.72	7.82	146.0	15.3
90	16.0	0.6	1.4	163.6	8.41	134.9	110.1	5.70	109.2	80.8	0.74	9.37	141.1	11.6
	22.0	1.2	2.8	166.2	8.53	137.1	110.7	5.71	112.6	83.3	0.74	8.94	143.1	12.6
	30.0	2.4	5.5	168.7	8.63	139.3	111.4	5.73	114.9	85.0	0.74	8.65	144.4	13.3
100	16.0	0.5	1.2	Operation not recommended					Operation not recommended					
	22.0	1.1	2.5						108.9	81.7	0.75	10.19	143.7	10.7
	30.0	2.3	5.3						110.6	82.3	0.74	9.87	144.2	11.2
110	16.0	0.5	1.2	Operation not recommended					Operation not recommended					
	22.0	1.1	2.5						104.1	78.5	0.75	11.39	142.9	9.1
	30.0	2.2	5.1						106.2	79.7	0.75	11.08	144.0	9.6
120	16.0	0.5	1.2	Operation not recommended					Operation not recommended					
	22.0	1.0	2.3						99.7	76.2	0.76	12.73	143.1	7.8
	30.0	2.1	4.9						101.8	77.4	0.76	12.36	144.0	8.2

Interpolation is permissible, extrapolation is not.

3/30/21

All entering air conditions are 80°F DB and 67°F WB in Cooling and 70°F DB in Heating.

All performance data is based upon the lower voltage of dual voltage units.

Operation below 60°F EWT requires optional insulated water/refrigerant circuit.

Operation below 40°F EWT is based upon 15% antifreeze solution.

See performance correction tables for operating conditions other than those listed above.

150 - Part Load Horizontal - Performance Data

Capacity Data (2300 CFM)

EWT °F	WATER FLOW GPM	WPD		HEATING - EAT 70 °F					COOLING - EAT 80/67 °F					
		PSI	FT	HC	KW	HE	LAT	COP	TC	SC	S/T	KW	HR	EER
20	12.0	1.7	3.9	Operation not recommended					Operation not recommended					
	15.0	2.1	4.9											
	18.0	2.5	5.8	27.4	2.4	19.1	79.0	3.3						
30	12.0	1.6	3.7	Operation not recommended					Operation not recommended					
	15.0	2.0	4.6	36.1	3.18	25.3	82.6	3.33	84.9	62.6	0.74	3.20	95.8	26.6
	18.0	2.4	5.5	36.7	3.22	25.7	82.8	3.34	86.1	63.8	0.74	3.00	96.3	28.7
40	12.0	1.5	3.5	49.3	3.72	36.6	87.9	3.88	80.9	59.9	0.74	3.46	92.7	23.4
	15.0	1.9	4.4	57.7	4.22	43.3	91.2	4.01	83.6	62.1	0.74	3.36	95.0	24.8
	18.0	2.3	5.3	50.9	3.82	37.8	88.5	3.90	85.2	63.6	0.75	3.20	96.1	26.7
50	12.0	1.4	3.2	63.1	4.31	48.3	93.4	4.29	80.1	60.1	0.75	3.67	92.6	21.8
	15.0	1.8	4.2	64.0	4.36	49.1	93.8	4.30	82.2	61.6	0.75	3.53	94.2	23.3
	18.0	2.2	5.1	65.0	4.42	49.9	94.2	4.31	84.3	63.2	0.75	3.39	95.9	24.9
60	12.0	1.3	3.0	70.5	4.46	55.3	96.4	4.63	76.5	58.1	0.76	4.04	90.3	19.0
	15.0	1.7	3.9	71.6	4.52	56.2	96.8	4.65	78.5	59.7	0.76	3.88	91.8	20.2
	18.0	2.1	4.9	72.7	4.58	57.1	97.3	4.66	80.6	61.2	0.76	3.73	93.3	21.6
70	12.0	1.2	2.8	78.0	4.61	62.3	99.4	4.96	73.0	56.2	0.77	4.40	88.0	16.6
	15.0	1.6	3.7	79.2	4.67	63.3	99.9	4.97	74.9	57.7	0.77	4.23	89.3	17.7
	18.0	2.0	4.6	80.4	4.73	64.3	100.4	4.98	76.8	59.1	0.77	4.06	90.7	18.9
80	12.0	1.1	2.5	85.7	4.81	69.3	102.5	5.22	71.4	55.7	0.78	4.79	87.8	14.9
	15.0	1.5	3.5	87.1	4.87	70.4	103.1	5.24	73.5	57.3	0.78	4.57	89.1	16.1
	18.0	1.9	4.4	88.4	4.94	71.6	103.6	5.25	75.2	58.6	0.78	4.42	90.3	17.0
90	12.0	1.0	2.3	93.5	5.01	76.4	105.6	5.47	69.9	55.2	0.79	5.18	87.6	13.5
	15.0	1.4	3.2	95.0	5.08	77.6	106.2	5.48	72.1	57.0	0.79	4.94	89.0	14.6
	18.0	1.8	4.2	96.4	5.14	78.9	106.8	5.50	73.6	58.1	0.79	4.78	89.9	15.4
100	12.0	0.9	2.1	Operation not recommended					Operation not recommended					
	15.0	1.3	3.0						67.6	54.1	0.80	5.27	85.6	12.8
	18.0	1.7	3.9						68.7	54.6	0.79	5.11	86.1	13.4
110	12.0	0.8	1.8	Operation not recommended					Operation not recommended					
	15.0	1.2	2.8						62.4	50.2	0.80	5.58	81.5	11.2
	18.0	1.6	3.7						63.7	51.0	0.80	5.43	82.2	11.7
120	12.0	0.7	1.6	Operation not recommended					Operation not recommended					
	15.0	1.1	2.5						60.9	49.3	0.81	6.49	83.0	9.4
	18.0	1.5	3.5						61.0	50.0	0.82	6.30	82.5	9.7

Interpolation is permissible, extrapolation is not.

3/30/21

All entering air conditions are 80°F DB and 67°F WB in Cooling and 70°F DB in Heating.

All performance data is based upon the lower voltage of dual voltage units.

Operation below 60°F EWT requires optional insulated water/refrigerant circuit.

Operation below 40°F EWT is based upon 15% antifreeze solution.

See performance correction tables for operating conditions other than those listed above.

150 - Full Load Horizontal - Performance Data

Capacity Data (4500 CFM)

EWT °F	WATER FLOW GPM	WPD		HEATING - EAT 70 °F					COOLING - EAT 80/67 °F					
		PSI	FT	HC	KW	HE	LAT	COP	TC	SC	S/T	KW	HR	EER
20	24.0	3.3	7.6	Operation not recommended					Operation not recommended					
	30.0	5.2	12.0											
	36.0	7.0	16.2	87.2	9.13	56.0	85.9	2.80						
30	24.0	3.2	7.4	Operation not recommended					Operation not recommended					
	30.0	5.1	11.8	95.1	9.16	63.8	87.6	3.04	170.0	109.9	0.65	6.50	192.1	26.2
	36.0	6.9	15.9	98.4	9.24	66.9	88.2	3.12	172.3	112.0	0.65	6.10	193.1	28.2
40	24.0	3.1	7.2	110.8	9.04	79.9	90.8	3.59	160.7	104.5	0.65	7.08	184.9	22.7
	30.0	5.0	11.6	115.3	9.22	83.8	91.7	3.66	166.0	108.4	0.65	6.88	189.4	24.1
	36.0	6.8	15.7	114.2	9.27	82.6	91.5	3.61	169.2	110.8	0.65	6.54	191.5	25.9
50	24.0	3.0	6.9	126.1	9.07	95.2	93.9	4.08	157.8	104.1	0.66	7.55	183.6	20.9
	30.0	4.9	11.3	128.1	9.18	96.7	94.3	4.09	161.9	106.9	0.66	7.26	186.7	22.3
	36.0	6.7	15.5	130.0	9.30	98.3	94.7	4.10	166.1	109.6	0.66	6.97	189.9	23.8
60	24.0	2.9	6.7	141.1	9.52	108.6	97.0	4.34	153.1	102.6	0.67	8.30	181.5	18.4
	30.0	4.8	11.1	143.3	9.64	110.4	97.5	4.36	157.2	105.3	0.67	7.98	184.4	19.7
	36.0	6.6	15.2	145.5	9.77	112.2	97.9	4.37	161.2	108.0	0.67	7.67	187.4	21.0
70	24.0	2.8	6.5	156.2	9.97	122.1	100.1	4.59	148.5	101.0	0.68	9.06	179.4	16.4
	30.0	4.7	10.9	158.6	10.10	124.1	100.6	4.60	152.4	103.6	0.68	8.71	182.1	17.5
	36.0	6.5	15.0	161.0	10.23	126.1	101.1	4.61	156.3	106.3	0.68	8.36	184.8	18.7
80	24.0	2.7	6.2	171.5	10.41	136.0	103.3	4.83	143.0	101.4	0.71	9.92	176.9	14.4
	30.0	4.6	10.6	174.2	10.54	138.2	103.8	4.84	147.1	104.3	0.71	9.46	179.4	15.6
	36.0	6.4	14.8	176.9	10.68	140.4	104.4	4.86	150.6	106.7	0.71	9.16	181.8	16.4
90	24.0	2.6	6.0	186.9	10.84	149.9	106.5	5.05	137.6	101.8	0.74	10.78	174.3	12.8
	30.0	4.5	10.4	189.8	10.99	152.3	107.1	5.06	141.9	105.0	0.74	10.28	177.0	13.8
	36.0	6.3	14.6	192.7	11.12	154.8	107.7	5.08	144.8	107.2	0.74	9.95	178.7	14.6
100	24.0	2.5	5.8	Operation not recommended					Operation not recommended					
	30.0	4.4	10.2						136.0	101.3	0.75	11.41	174.9	11.9
	36.0	6.2	14.3						138.1	102.2	0.74	11.05	175.7	12.5
110	24.0	2.4	5.5	Operation not recommended					Operation not recommended					
	30.0	4.3	9.9						128.7	95.7	0.74	12.48	171.3	10.3
	36.0	6.1	14.1						131.3	97.2	0.74	12.14	172.7	10.8
120	24.0	2.3	5.3	Operation not recommended					Operation not recommended					
	30.0	4.2	9.7						122.2	91.0	0.74	14.35	171.1	8.5
	36.0	6.0	13.9						124.8	92.4	0.74	13.93	172.3	9.0

Interpolation is permissible, extrapolation is not.

3/30/21

All entering air conditions are 80°F DB and 67°F WB in Cooling and 70°F DB in Heating.

All performance data is based upon the lower voltage of dual voltage units.

Operation below 60°F EWT requires optional insulated water/refrigerant circuit.

Operation below 40°F EWT is based upon 15% antifreeze solution.

See performance correction tables for operating conditions other than those listed above.

180 - Part Load Horizontal - Performance Data

Capacity Data (2800 CFM)

EWT °F	WATER FLOW GPM	WPD		HEATING - EAT 70 °F					COOLING - EAT 80/67 °F					
		PSI	FT	HC	KW	HE	LAT	COP	TC	SC	S/T	KW	HR	EER
20	20.0	1.7	3.9	Operation not recommended					Operation not recommended					
	24.0	2.2	5.1	Operation not recommended					Operation not recommended					
	28.0	2.6	6.0	44.6	4.32	29.9	82.7	3.03	Operation not recommended					
30	20.0	1.6	3.7	Operation not recommended					Operation not recommended					
	24.0	2.1	4.9	52.8	4.79	36.4	85.4	3.23	98.2	68.3	0.70	3.71	110.8	26.5
	28.0	2.5	5.8	54.4	4.91	37.6	86.0	3.25	99.5	69.7	0.70	3.48	111.4	28.6
40	20.0	1.5	3.5	62.8	5.07	45.4	88.8	3.62	92.9	66.9	0.72	4.12	107.0	22.5
	24.0	2.0	4.6	67.0	5.26	49.0	90.1	3.73	95.9	68.8	0.72	4.00	109.6	24.0
	28.0	2.4	5.5	64.7	5.21	46.9	89.4	3.64	97.8	70.4	0.72	3.81	110.8	25.7
50	20.0	1.4	3.2	72.8	5.36	54.5	92.1	3.98	91.3	67.6	0.74	4.47	106.6	20.4
	24.0	1.9	4.4	73.9	5.43	55.3	92.4	3.99	93.7	69.3	0.74	4.30	108.4	21.8
	28.0	2.3	5.3	75.0	5.50	56.2	92.8	4.00	96.1	71.1	0.74	4.13	110.2	23.3
60	20.0	1.3	3.0	80.8	5.54	61.9	94.7	4.28	88.8	65.3	0.74	4.99	105.8	17.8
	24.0	1.8	4.2	82.1	5.61	62.9	95.1	4.29	91.1	67.0	0.74	4.80	107.5	19.0
	28.0	2.2	5.1	83.3	5.68	63.9	95.5	4.30	93.5	68.7	0.74	4.61	109.2	20.3
70	20.0	1.2	2.8	88.9	5.71	69.4	97.4	4.56	86.3	63.0	0.73	5.51	105.1	15.6
	24.0	1.7	3.9	90.2	5.79	70.5	97.8	4.57	88.5	64.6	0.73	5.30	106.6	16.7
	28.0	2.1	4.9	91.6	5.86	71.6	98.3	4.58	90.8	66.3	0.73	5.09	108.2	17.8
80	20.0	1.1	2.5	97.5	5.88	77.5	100.3	4.86	83.0	62.2	0.75	6.03	103.6	13.8
	24.0	1.6	3.7	99.0	5.96	78.7	100.8	4.87	85.4	64.0	0.75	5.76	105.1	14.8
	28.0	2.0	4.6	100.6	6.03	80.0	101.3	4.89	87.4	65.5	0.75	5.57	106.4	15.7
90	20.0	1.0	2.3	106.2	6.05	85.6	103.1	5.15	79.8	61.4	0.77	6.55	102.2	12.2
	24.0	1.5	3.5	107.9	6.12	87.0	103.7	5.16	82.3	63.4	0.77	6.25	103.6	13.2
	28.0	1.9	4.4	109.5	6.20	88.3	104.2	5.18	84.0	64.7	0.77	6.05	104.6	13.9
100	20.0	0.9	2.1	Operation not recommended					Operation not recommended					
	24.0	1.4	3.2	Operation not recommended					79.6	62.5	0.78	6.75	102.6	11.8
	28.0	1.8	4.2	Operation not recommended					80.8	63.0	0.78	6.54	103.1	12.4
110	20.0	0.8	1.8	Operation not recommended					Operation not recommended					
	24.0	1.3	3.0	Operation not recommended					76.0	60.4	0.79	7.22	100.7	10.5
	28.0	1.7	3.9	Operation not recommended					77.6	61.3	0.79	7.02	101.6	11.1
120	20.0	0.7	1.6	Operation not recommended					Operation not recommended					
	24.0	1.2	2.8	Operation not recommended					74.2	59.9	0.81	7.93	101.3	9.4
	28.0	1.6	3.7	Operation not recommended					75.8	60.8	0.80	7.70	102.1	9.8

Interpolation is permissible, extrapolation is not.

All entering air conditions are 80°F DB and 67°F WB in Cooling and 70°F DB in Heating.

All performance data is based upon the lower voltage of dual voltage units.

Operation below 60°F EWT requires optional insulated water/refrigerant circuit.

Operation below 40°F EWT is based upon 15% antifreeze solution.

See performance correction tables for operating conditions other than those listed above.

3/30/21

180 - Full Load Horizontal - Performance Data

Capacity Data (5200 CFM)

EWT °F	WATER FLOW GPM	WPD		HEATING - EAT 70 °F					COOLING - EAT 80/67 °F					
		PSI	FT	HC	KW	HE	LAT	COP	TC	SC	S/T	KW	HR	EER
20	22.0	1.9	4.4	Operation not recommended					Operation not recommended					
	34.0	3.1	7.2	Operation not recommended					Operation not recommended					
	45.0	4.3	9.9	103.2	11.02	65.6	86.4	2.74	Operation not recommended					
30	22.0	1.8	4.2	Operation not recommended					Operation not recommended					
	34.0	3.0	6.9	120.4	11.51	81.1	89.4	3.07	194.1	128.3	0.66	9.19	225.5	21.1
	45.0	4.2	9.7	122.2	11.65	82.5	89.8	3.07	198.1	130.7	0.66	8.89	228.4	22.3
40	22.0	1.7	3.9	137.8	11.87	97.3	92.5	3.40	184.2	123.4	0.67	10.20	219.0	18.0
	34.0	2.9	6.7	145.7	12.23	104.0	93.9	3.49	189.6	127.1	0.67	9.77	222.9	19.4
	45.0	4.1	9.5	142.1	12.18	100.6	93.3	3.42	193.9	129.8	0.67	9.42	226.0	20.6
50	22.0	1.6	3.7	157.1	12.38	114.9	96.0	3.72	180.1	122.5	0.68	10.78	216.9	16.7
	34.0	2.8	6.5	159.7	12.55	116.9	96.4	3.73	185.1	125.8	0.68	10.35	220.4	17.9
	45.0	4.0	9.2	162.0	12.70	118.7	96.8	3.74	189.6	128.9	0.68	9.95	223.5	19.1
60	22.0	1.5	3.5	173.2	12.71	129.9	98.8	3.99	176.8	122.0	0.69	11.56	216.3	15.3
	34.0	2.7	6.2	176.0	12.88	132.1	99.3	4.00	181.6	125.3	0.69	11.10	219.5	16.4
	45.0	3.8	8.8	178.6	13.04	134.1	99.8	4.01	186.1	128.4	0.69	10.68	222.5	17.4
70	22.0	1.4	3.2	189.3	13.05	144.8	101.7	4.25	173.5	121.4	0.70	12.35	215.6	14.0
	34.0	2.6	6.0	192.4	13.22	147.3	102.3	4.27	178.2	124.8	0.70	11.85	218.7	15.0
	45.0	3.6	8.3	195.2	13.38	149.5	102.8	4.28	182.6	127.8	0.70	11.40	221.5	16.0
80	22.0	1.3	3.0	206.8	13.40	161.1	104.8	4.52	169.7	116.3	0.69	13.32	215.1	12.7
	34.0	2.5	5.8	210.1	13.57	163.7	105.4	4.54	174.7	119.7	0.69	12.71	218.0	13.7
	45.0	3.5	8.1	213.2	13.74	166.3	106.0	4.55	178.6	122.4	0.69	12.30	220.6	14.5
90	22.0	1.2	2.8	224.3	13.75	177.4	107.9	4.78	165.9	111.1	0.67	14.30	214.7	11.6
	34.0	2.4	5.5	227.7	13.93	180.2	108.6	4.79	171.1	114.6	0.67	13.64	217.6	12.5
	45.0	3.3	7.6	231.2	14.10	183.1	109.2	4.81	174.6	117.0	0.67	13.20	219.6	13.2
100	22.0	1.1	2.5	Operation not recommended					Operation not recommended					
	34.0	2.3	5.3						167.9 113.3 0.67 14.93 218.9 11.2					
	45.0	3.2	7.4						170.5 114.2 0.67 14.45 219.8 11.8					
110	22.0	1.0	2.3	Operation not recommended					Operation not recommended					
	34.0	2.2	5.1						163.1 109.8 0.67 16.14 218.1 10.1					
	45.0	3.1	7.2						166.4 111.5 0.67 15.70 220.0 10.6					
120	22.0	0.9	2.1	Operation not recommended					Operation not recommended					
	34.0	2.1	4.9						158.4 108.4 0.68 17.82 219.2 8.9					
	45.0	3.0	6.9						161.8 110.0 0.68 17.30 220.8 9.4					

Interpolation is permissible, extrapolation is not.

3/30/21

All entering air conditions are 80°F DB and 67°F WB in Cooling and 70°F DB in Heating.

All performance data is based upon the lower voltage of dual voltage units.

Operation below 60°F EWT requires optional insulated water/refrigerant circuit.

Operation below 40°F EWT is based upon 15% antifreeze solution.

See performance correction tables for operating conditions other than those listed above.

Wiring Schematics

Single Compressor 208-230/60/3

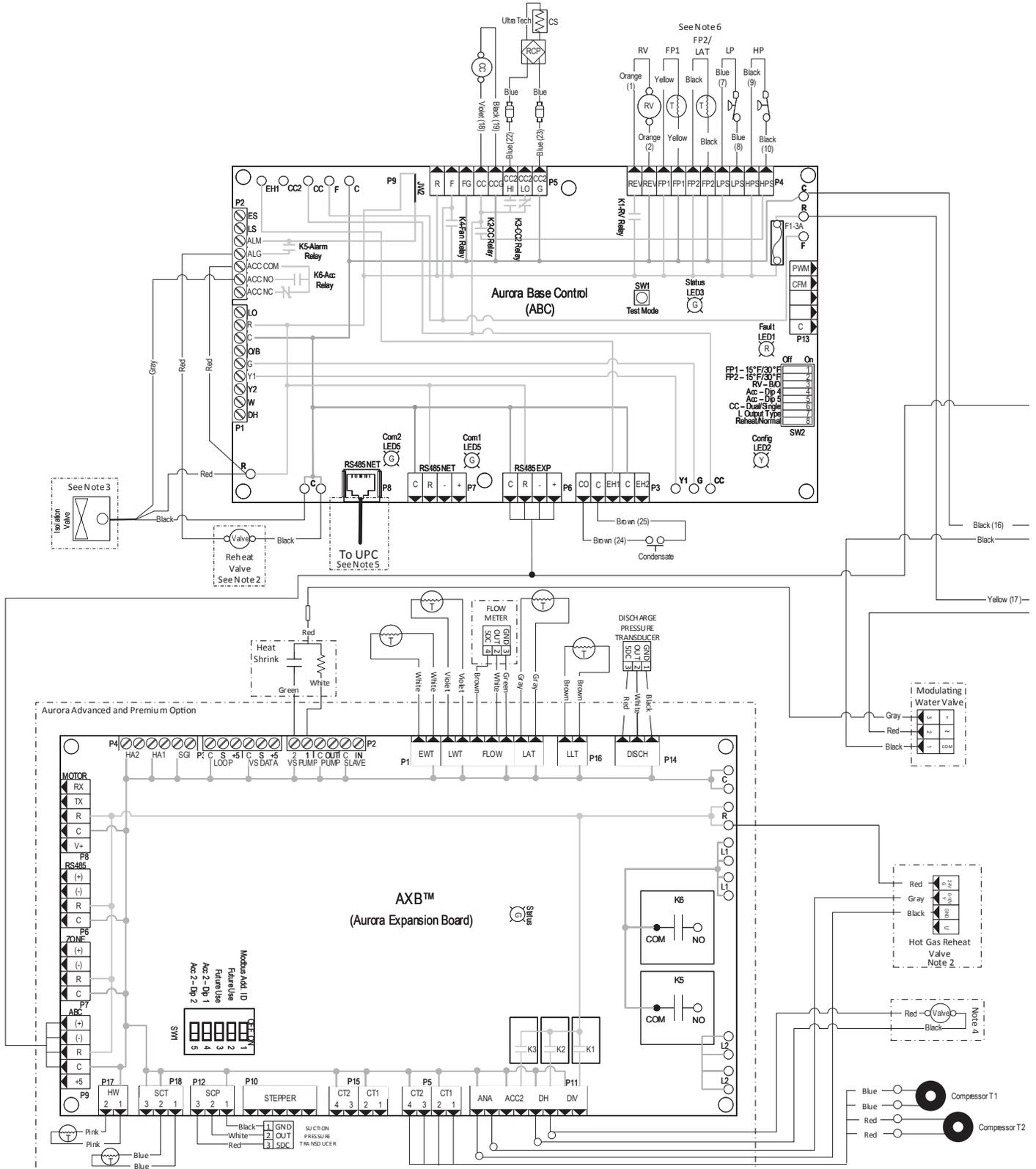

Wiring Schematics cont.

Single Compressor 208-230/60/3

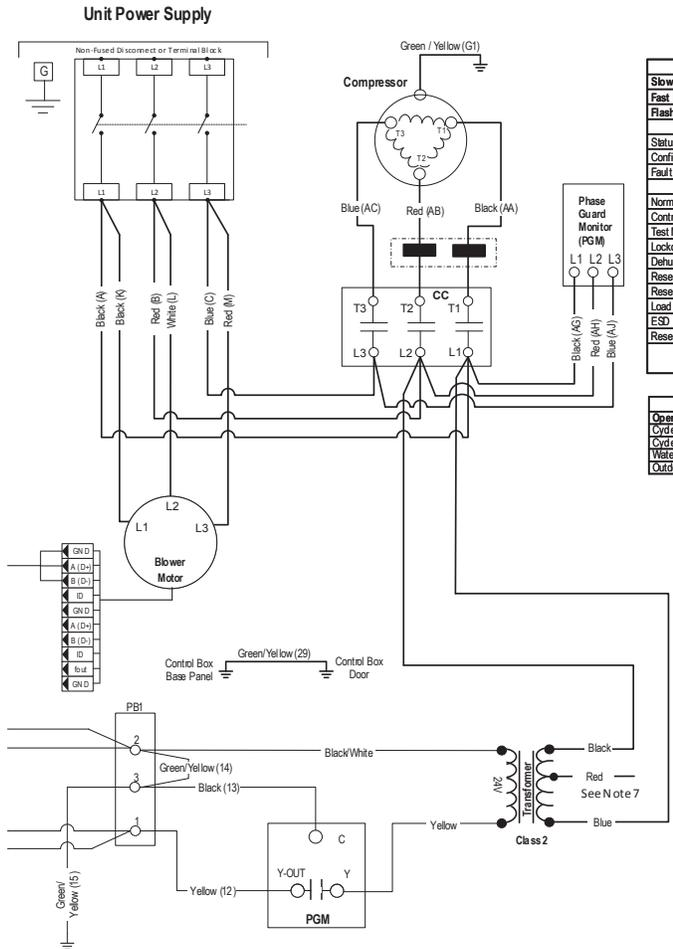

Aurora LED Flash Codes		
Slow Flash	1 second on and 1 second off	
Fast Flash	100 milliseconds on and 100 milliseconds off	
Flash Code	100 milliseconds on and 400 milliseconds off with a 2 second pause before repeating	
Random Start Delay		
Status LED (LED3, Green)	Fast Flash	
Configuration LED (LED2, Yellow)	Fast Flash	
Fault LED (LED1, Red)	Fast Flash	
Status LED (LED3, Green)	Configuration LED (LED2, Yellow)	Fault LED (LED1, Red)
Normal Mode	ON	No Software Override
Control is Non-Functional	OFF	DP Switch Override
Test Mode	Slow Flash	Flash ECM Setting
Lockout Active	Fast Flash	Reset Configure Mode
Dehumidification Mode	Flash Code 2	Normal Mode
Reserved	Flash Code 3	Input Fault Lockout
Reserved	Flash Code 4	High Pressure Lockout
Load Shed	Flash Code 5	Low Pressure Lockout
ESD	Flash Code 6	Low Air Coil Limit Lockout - FP2
Reserved	Flash Code 7	Low Water Coil Limit Lockout - FP1
		Loss of Charge Lockout
		Condensate Overflow Lockout
		Over/Under Voltage Shutdown
		Compressor Monitor Lockout
		Air/Water Coil Limit Sensor Error

Accessory Relay	
Operation	SW2-4 SW2-5
Cycle with Blower	On On
Cycle with Compressor	Off Off
Water Valve Slow Open	On Off
Outdoor Air Damper	Off On

Aurora Timing Events		
Event	Normal Mode	Test Mode
Random Start Delay	5 to 80 seconds	1 second
Compressor On Delay	5 seconds	< 1 second
Compressor Minimum On Time	2 minutes	5 seconds
Compressor Short Cycle Delay	4 minutes	15 seconds
Blower Off Delay	30 seconds	2 seconds
Fault Recognition Delay - High Pressure	Less than 1 second	Less than 1 second
Start-Up Bypass - Low Pressure	2 minutes	30 seconds
Fault Recognition Delay - Low Pressure	30 seconds	30 seconds
Start-Up Bypass - Low Water/Air Coil Limit	2 minutes	30 seconds
Fault Recognition Delay - Low Water/Air Coil Limit	30 seconds	30 seconds
Fault Recognition Delay - Condensate Overflow	30 seconds	30 seconds
Thermostat Call Recognition Time	2 seconds	2 seconds
Auxiliary Heat Staging Delay	5 minutes	20 seconds
Emergency Heat Staging Delay	2 minutes	7.5 seconds
Water Valve Slow Open Delay	90 seconds	90 seconds
Reheat Delay	30 seconds	30 seconds

Notes:

- 1 - P1 (screw terminals) and P9 (Molex connector) are adjacent and share common terminals the same order.
- 2 - Optional factory installed hot gas reheat or modulating hot gas reheat.
- 3 - Optional factory installed internal isolation valve.
- 4 - Optional water side economizer.
- 5 - See supplemental schematic for AXB and/or UPC connections.
- 6 - LAT location with Aurora Base Controls, FP2 with Aurora Advanced and Premium Controls
- 7 - Swap blue and red leads for 208V operation.

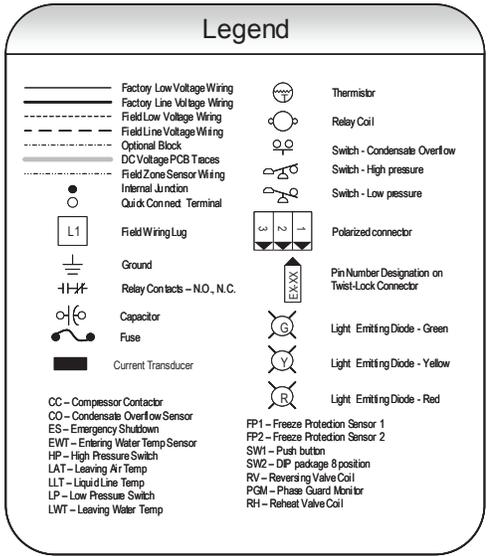
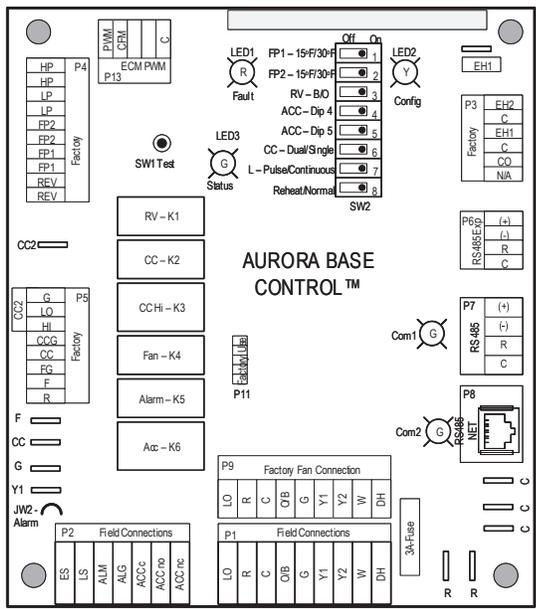

Wiring Schematics cont.

Single Compressor 460/60/3

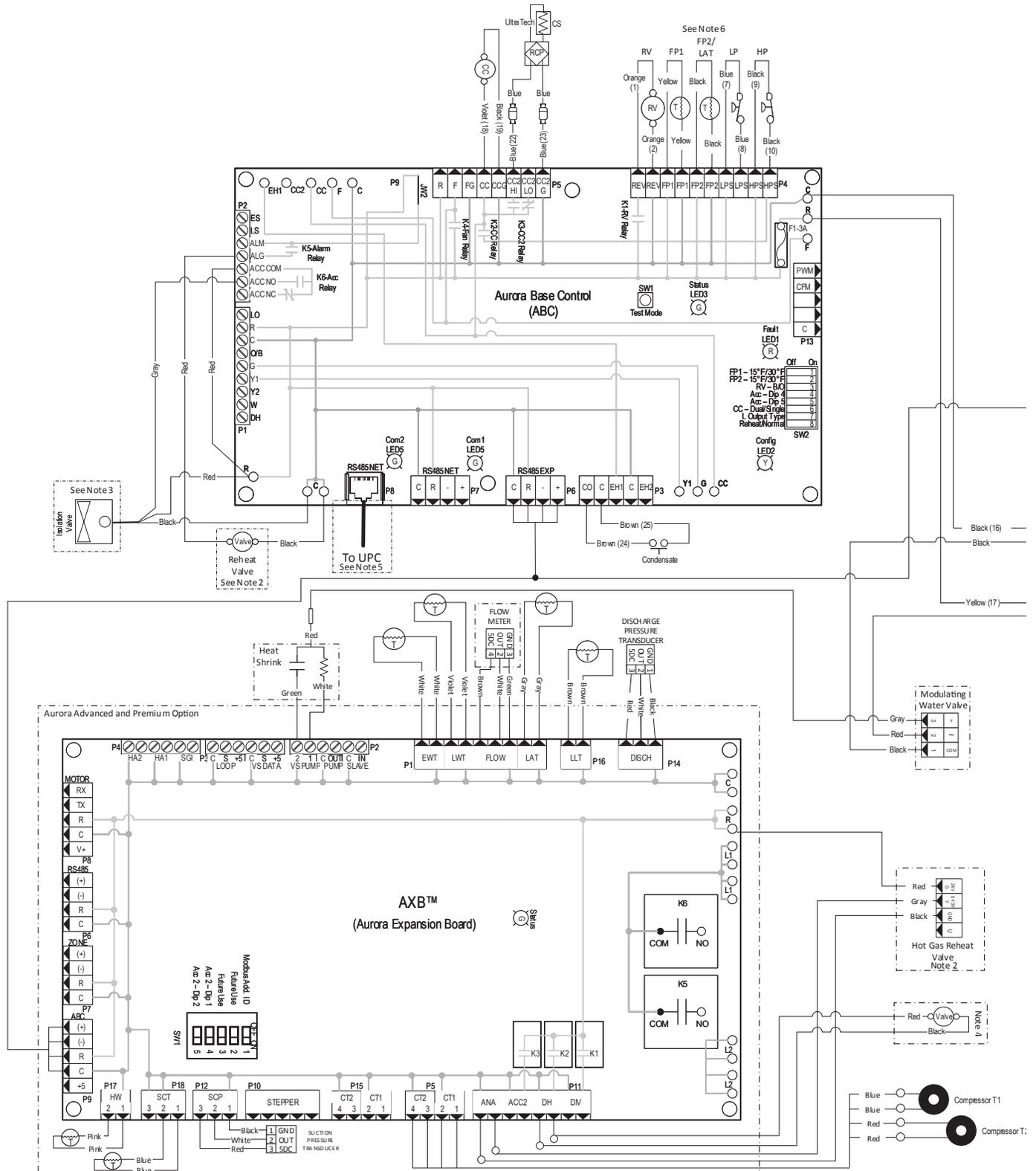

Wiring Schematics cont.

Dual Compressor 208-230/60/3

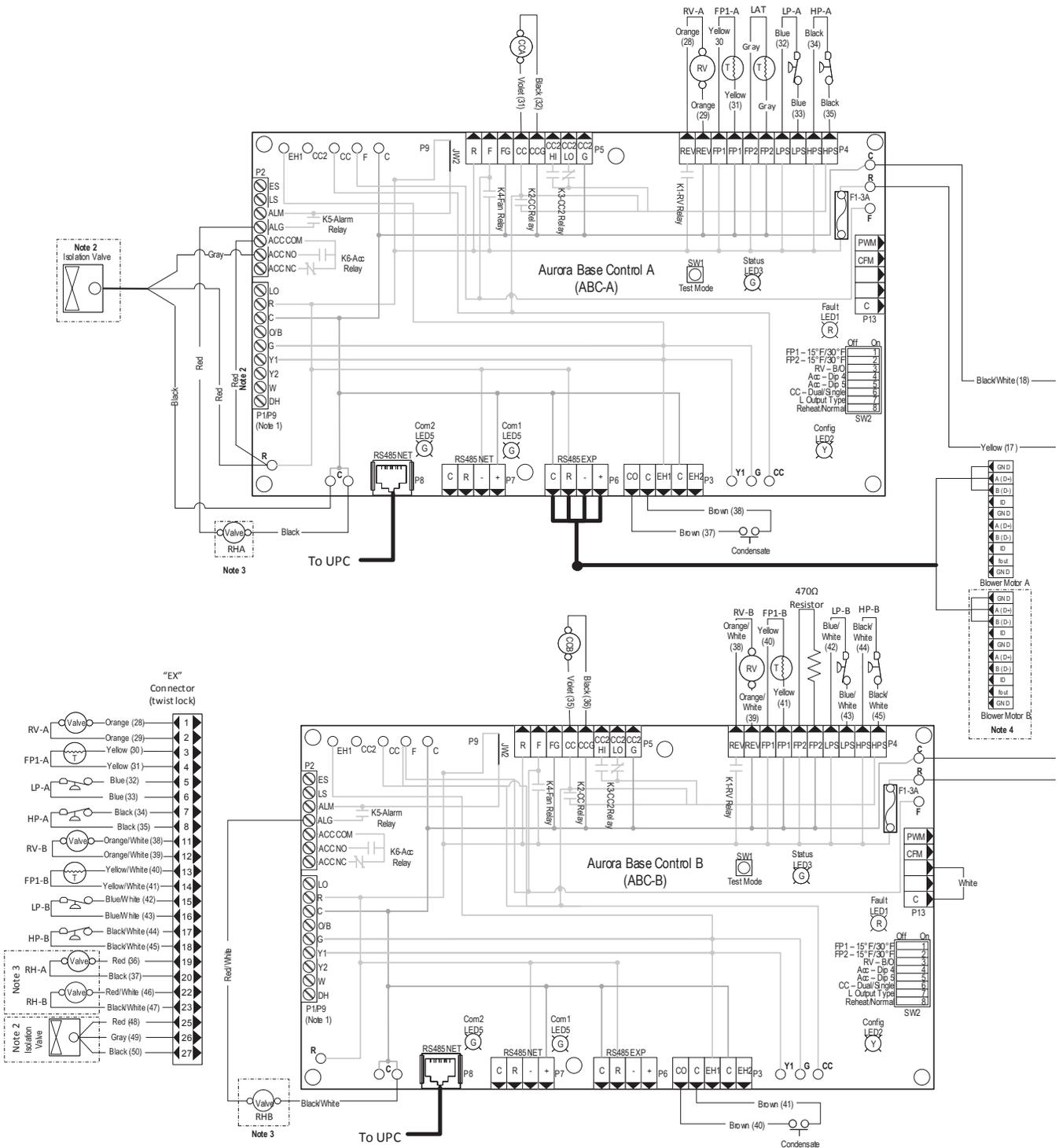

Wiring Schematics cont.

Dual Compressor 208-230/60/3

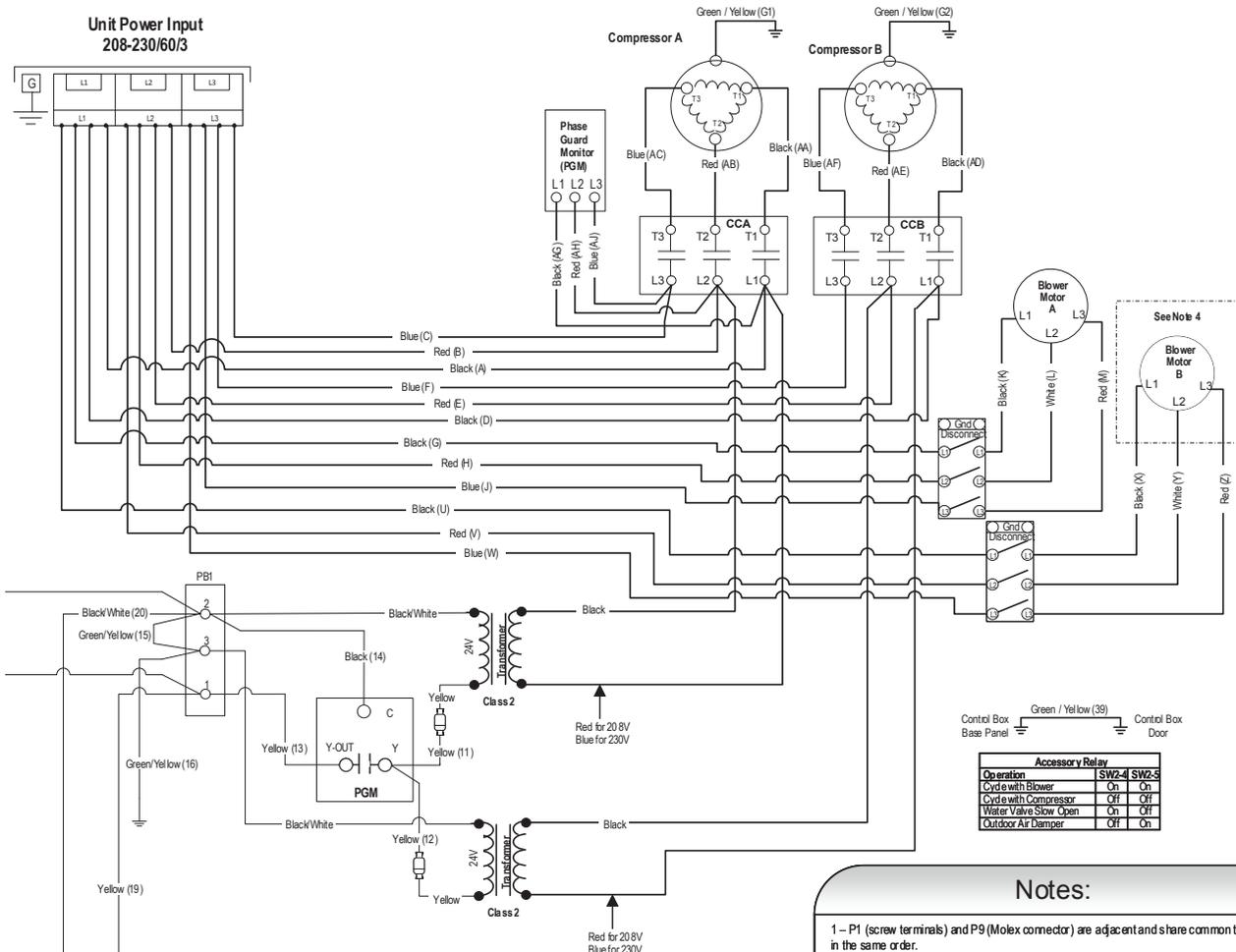

Accessory Relay		
Operation	SW2-4	SW2-5
Cycle with Blower	On	On
Cycle with Compressor	Off	Off
Water Valve Slow Open	On	Off
Outdoor Air Damper	Off	On

Notes:

- 1 - P1 (screw terminals) and P9 (Molex connector) are adjacent and share common terminals in the same order.
- 2 - Optional isolation water valve.
- 3 - Optional hot gas reheat.
- 4 - Sizes 240-360 equipped with two blowers.

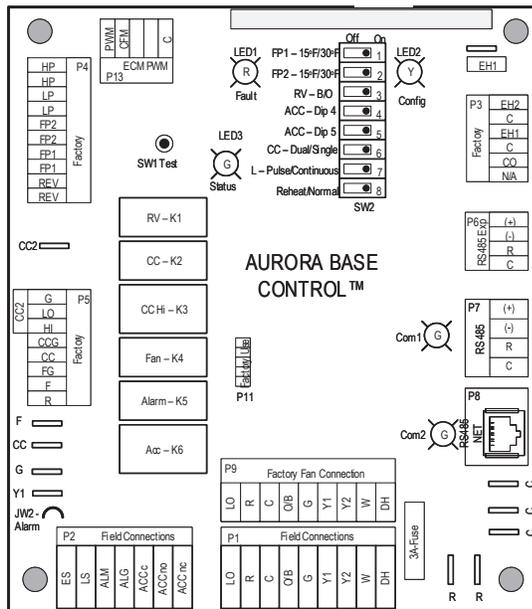

Legend

- Factory Low Voltage Wiring
- Factory Line Voltage Wiring
- Field Low Voltage Wiring
- Field Line Voltage Wiring
- Optional Block
- DC Voltage PCB Traces
- Field Zone Sensor Wiring
- Internal Junction
- Quick Connect Terminal
- Field Wiring Lug
- Ground
- Relay Contacts - N.O., N.C.
- Capacitor
- Fuse
- Thermistor
- Relay Coil
- Switch - Condensate Overflow
- Switch - High pressure
- Switch - Low pressure
- Polarized connector
- Pin Number Designation on Twist-Lock Connector
- Light Emitting Diode - Green
- Light Emitting Diode - Yellow
- Light Emitting Diode - Red

- SW1 - Push button
- SW2 - DIP package 8 position
- RV1 - Reversing Valve Coil 1
- RV2 - Reversing Valve Coil 2
- PGM - Phase Guard Monitor
- RH - Reheat Valve Coil

Wiring Schematics cont.

Dual Compressor 460/60/3

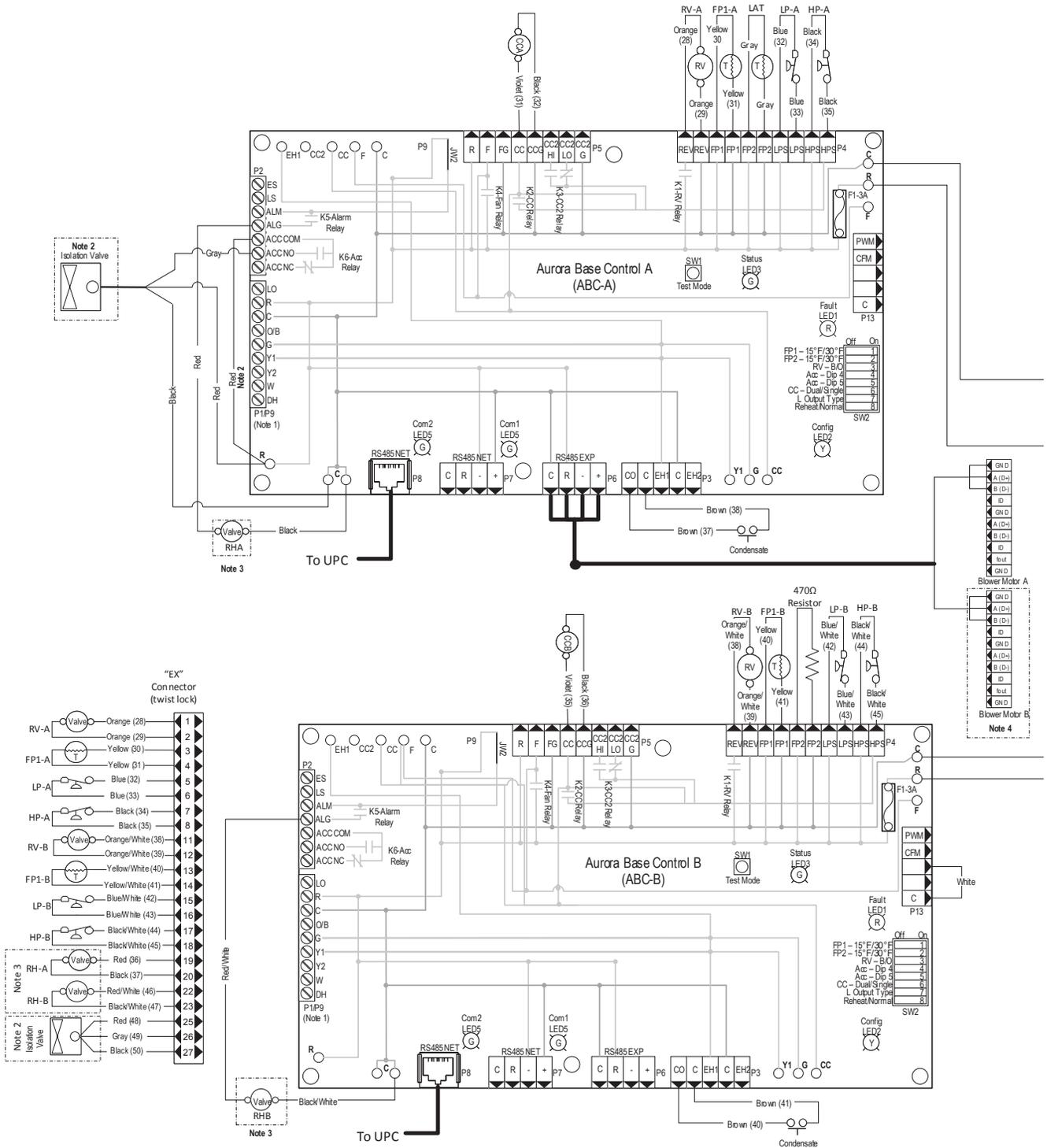

Wiring Schematics cont.

Dual Compressor 460/60/3

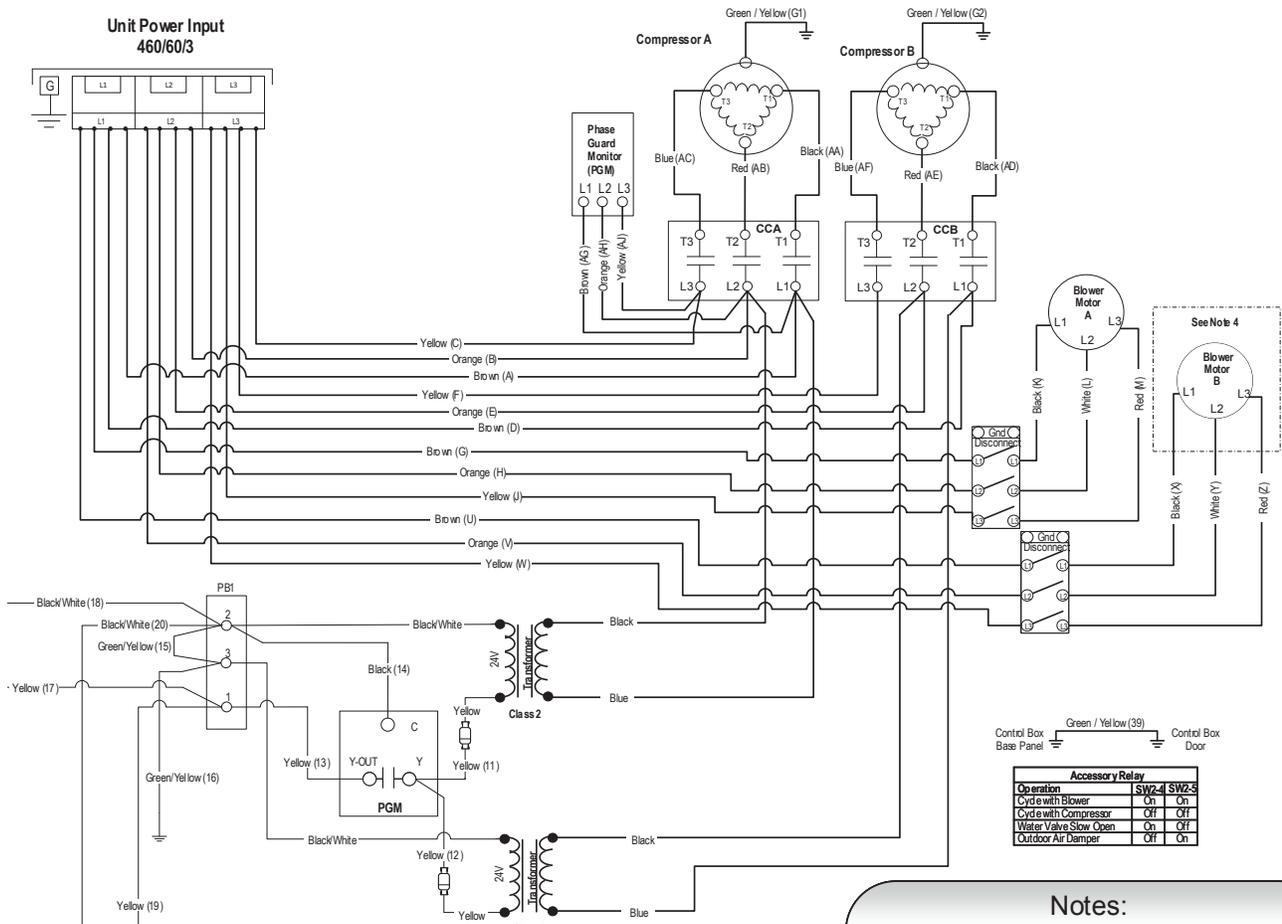

Notes:

- 1 - P1 (screw terminals) and P9 (Molex connector) are adjacent and share common terminals in the same order.
- 2 - Optional isolation water valve.
- 3 - Optional hot gas reheat.
- 4 - Sizes 240-360 equipped with two blowers.

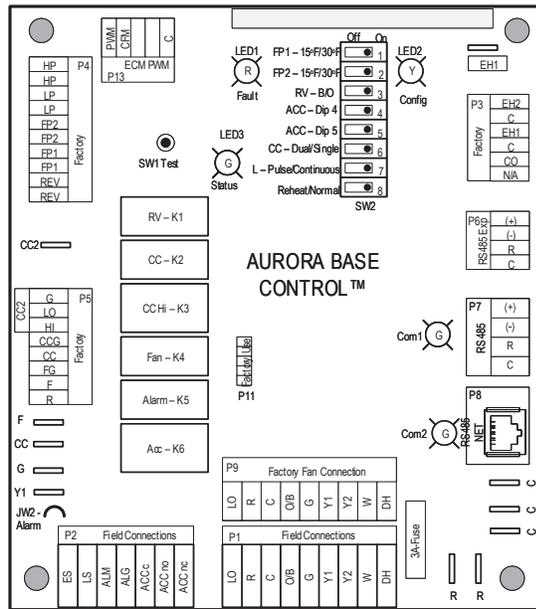

Legend

- Factory Low Voltage Wiring
- Factory Line Voltage Wiring
- Field Low Voltage Wiring
- Field Line Voltage Wiring
- Optional Block
- DC Voltage PCB Traces
- Field Zone Sensor Wiring
- Internal Junction
- Quick Connect Terminal
- Field Wiring Lug
- Ground
- Relay Contacts - N.O., N.C.
- Capacitor
- Fuse
- Thermistor
- Relay Coil
- Switch - Condensate Overflow
- Switch - High pressure
- Switch - Low pressure
- Polarized connector
- Pin Number Designation on Twist-Lock Connector
- Light Emitting Diode - Green
- Light Emitting Diode - Yellow
- Light Emitting Diode - Red

CCA - Compressor A Contactor
 CCB - Compressor B Contactor
 CO - Condensate Overflow Sensor
 ES - Emergency Shutdown
 HP1 - High Pressure Switch 1
 HP2 - High Pressure Switch 2
 LP1 - Low Pressure Switch 1
 LP2 - Low Pressure Switch 2
 FP1 - Freeze Protection Sensor 1
 FP2 - Freeze Protection Sensor 2
 F1 - Fuse

SW1 - Push button
 SW2 - DP package 8 position
 RV1 - Reversing Valve Coil 1
 RV2 - Reversing Valve Coil 2
 PGM - Phase Guard Monitor
 RH - Reheat Valve Coil

Wiring Schematics cont.

Dual Compressor Aurora Advanced and Premium 208-230/60/3

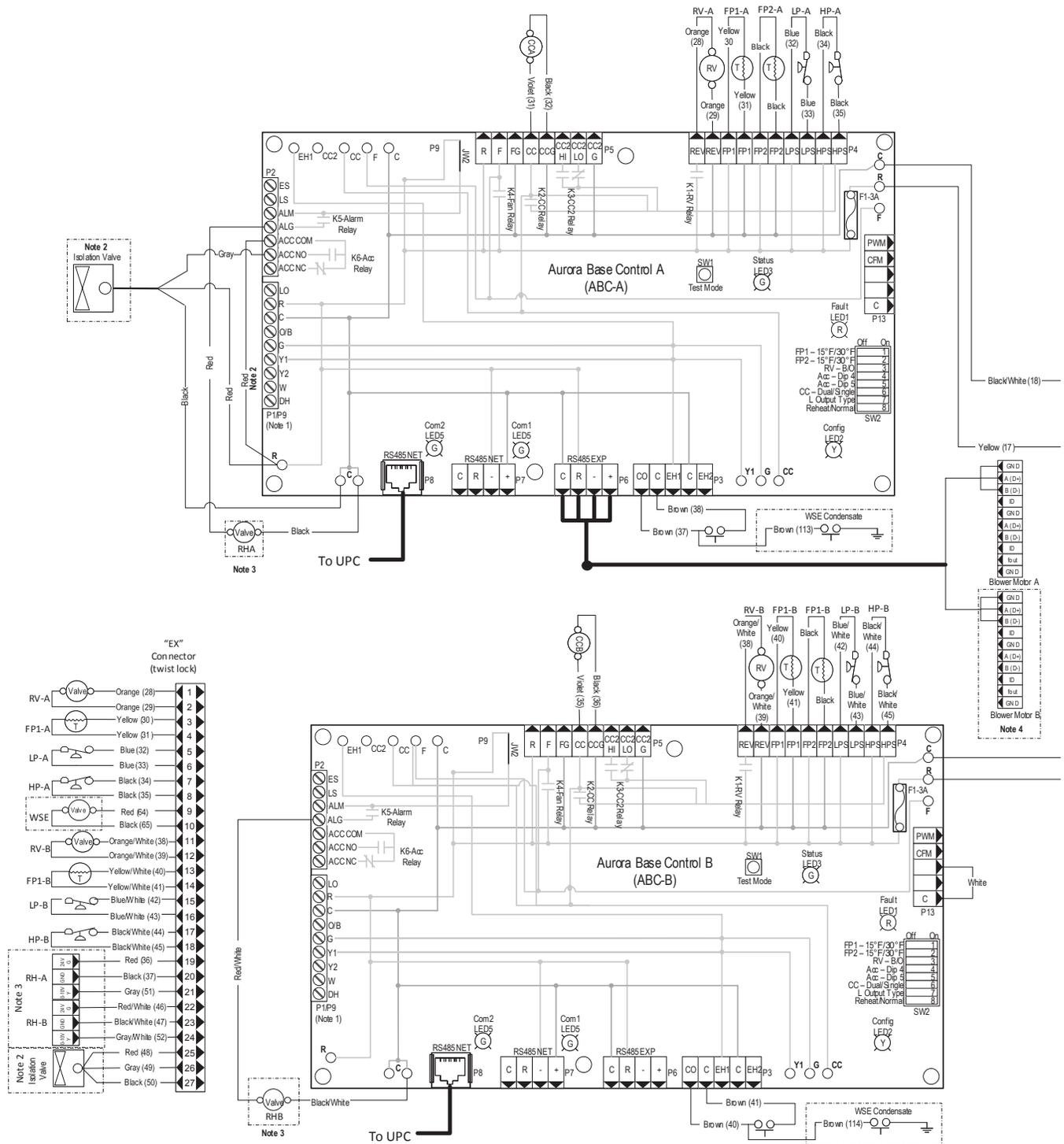

Wiring Schematics cont.

Dual Compressor Aurora Advanced and Premium 208-230/60/3

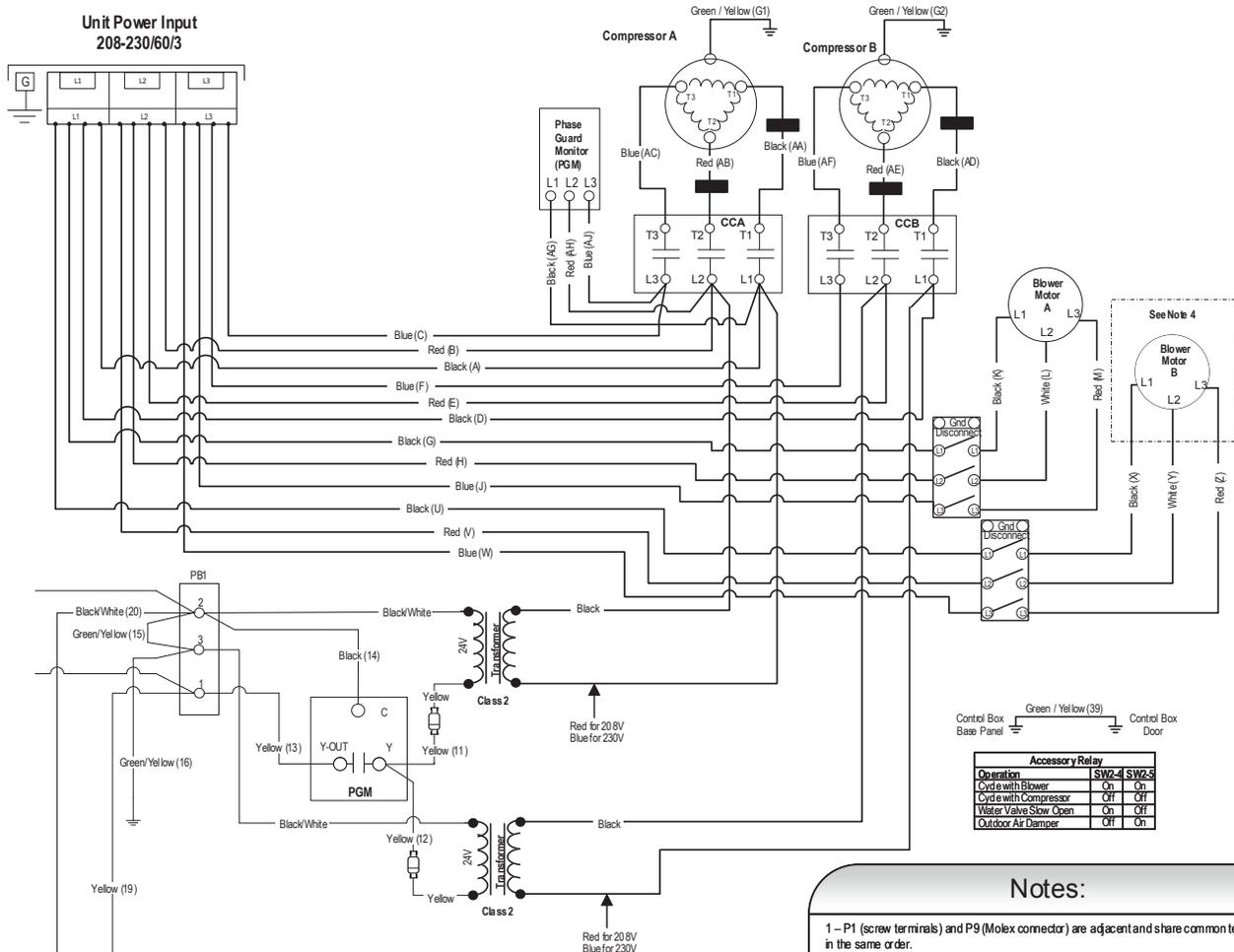

Operation	SW1	SW2
Cycle with Blower	On	On
Cycle with Compressor	Off	Off
Water Valve Slow Open	On	Off
Outdoor Air Damper	Off	On

Notes:

- 1 - P1 (screw terminals) and P9 (Molex connector) are adjacent and share common terminals in the same order.
- 2 - Optional isolation water valve.
- 3 - Optional hot gas reheat.
- 4 - Sizes 240-360 equipped with two blowers.

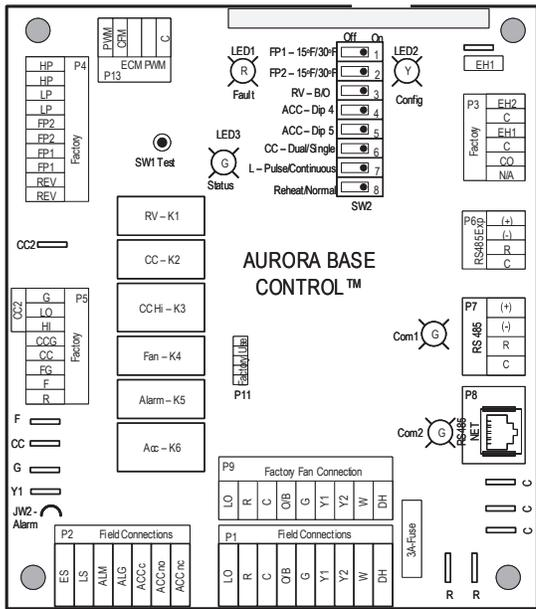

Legend

- Factory Low Voltage Wiring
- Factory Line Voltage Wiring
- Field Low Voltage Wiring
- Field Line Voltage Wiring
- Optional Block
- DC Voltage PCB Traces
- Field Zone Sensor Wiring
- Internal Junction
- Quick Connect Terminal
- Field Wiring Lug
- Ground
- Relay Contacts - N.O., N.C.
- Capacitor
- Fuse
- Current Transducer
- Thermistor
- Relay Coil
- Switch - Condensate Overflow
- Switch - High pressure
- Switch - Low pressure
- Polarized connector
- Pin Number Designation on Twist-Lock Connector
- Light Emitting Diode - Green
- Light Emitting Diode - Yellow
- Light Emitting Diode - Red

CCA - Compressor A Contactor
 CCB - Compressor B Contactor
 CO - Condensate Overflow Sensor
 ES - Emergency Shutdown
 HP1 - High Pressure Switch 1
 HP2 - High Pressure Switch 2
 LP1 - Low Pressure Switch 1
 LP2 - Low Pressure Switch 2
 FP1 - Freeze Protection Sensor 1
 FP2 - Freeze Protection Sensor 2
 F1 - Fuse

SW1 - Push button
 SW2 - DP package 8 position
 RV1 - Reversing Valve Coil 1
 RV2 - Reversing Valve Coil 2
 PGM - Phase Guard Monitor
 RH1 - Reheat Valve Coil

Wiring Schematics cont.

Dual Compressor Aurora Advanced and Premium 460/60/3

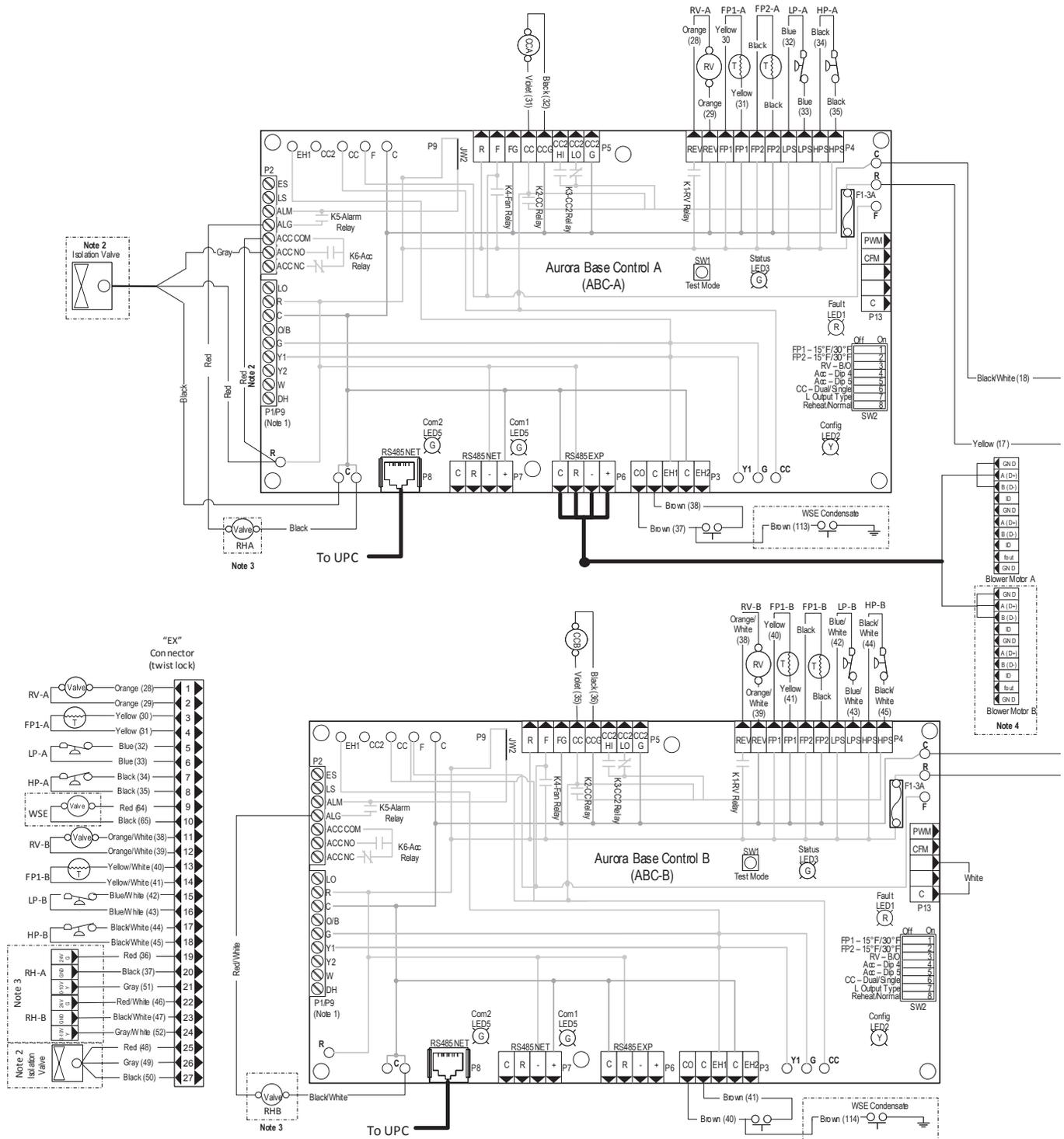

Wiring Schematics cont.

Dual Compressor Aurora Advanced and Premium 460/60/3

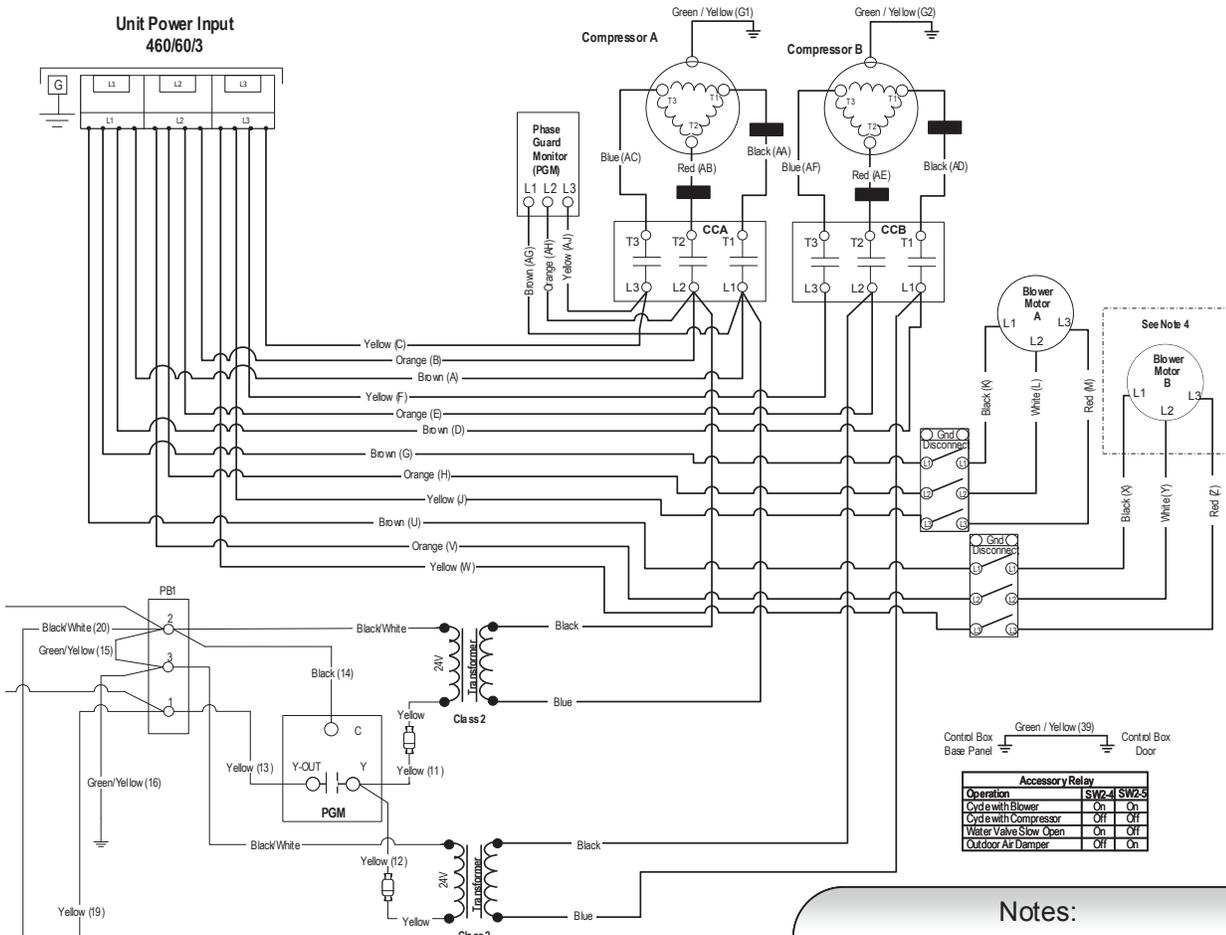

Notes:

- 1 - P1 (screw terminals) and P9 (Molex connector) are adjacent and share common terminals in the same order.
- 2 - Optional isolation water valve.
- 3 - Optional hot gas reheat.
- 4 - Sizes 240-360 equipped with two blowers.

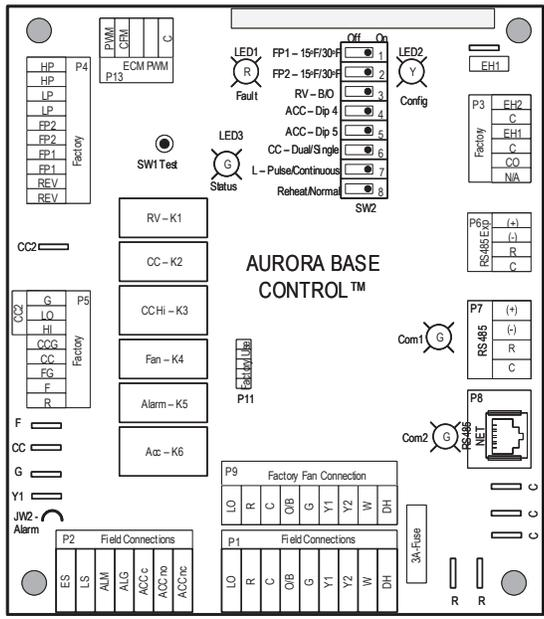

Legend

- Factory Low Voltage Wiring
- Factory Line Voltage Wiring
- Field Low Voltage Wiring
- Field Line Voltage Wiring
- Optional Block
- DC Voltage PCB Traces
- Field Zone Sensor Wiring
- Internal Junction
- Quick Connect Terminal
- Field Wiring Lug
- Ground
- Relay Contacts - NO, N.C.
- Capacitor
- Fuse
- Current Transducer
- Thermistor
- Relay Coil
- Switch - Condensate Overlow
- Switch - High pressure
- Switch - Low pressure
- Polarized connector
- Pin Number Designation on Twist-Lock Connector
- Light Emitting Diode - Green
- Light Emitting Diode - Yellow
- Light Emitting Diode - Red

CCA - Compressor A Contactor
 CCB - Compressor B Contactor
 CO - Condensate Overlow Sensor
 ES - Emergency Shutdown
 HP1 - High Pressure Switch 1
 HP2 - High Pressure Switch 2
 LP1 - Low Pressure Switch 1
 LP2 - Low Pressure Switch 2
 FP1 - Freeze Protection Sensor 1
 FP2 - Freeze Protection Sensor 2
 F1 - Fuse

SW1 - Push button
 SW2 - DIP package position
 RV1 - Reversing Valve Coil 1
 RV2 - Reversing Valve Coil 2
 PGM - Phase Guard Monitor
 RH - Reheat Valve Coil

Wiring Schematics cont.

Aurora Advanced and Premium Controls Add-on

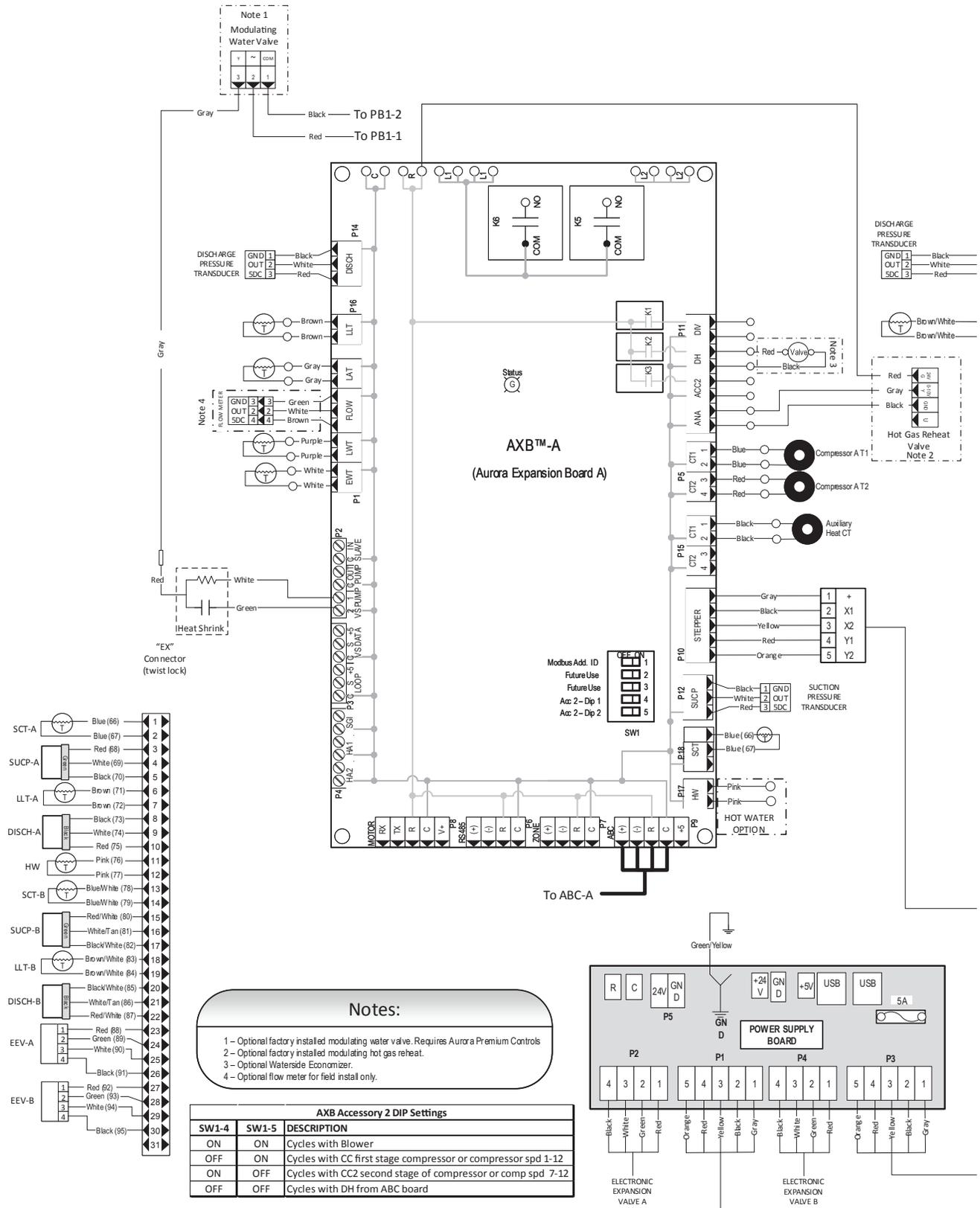

Wiring Schematics cont.

Aurora Advanced and Premium Controls Add-on

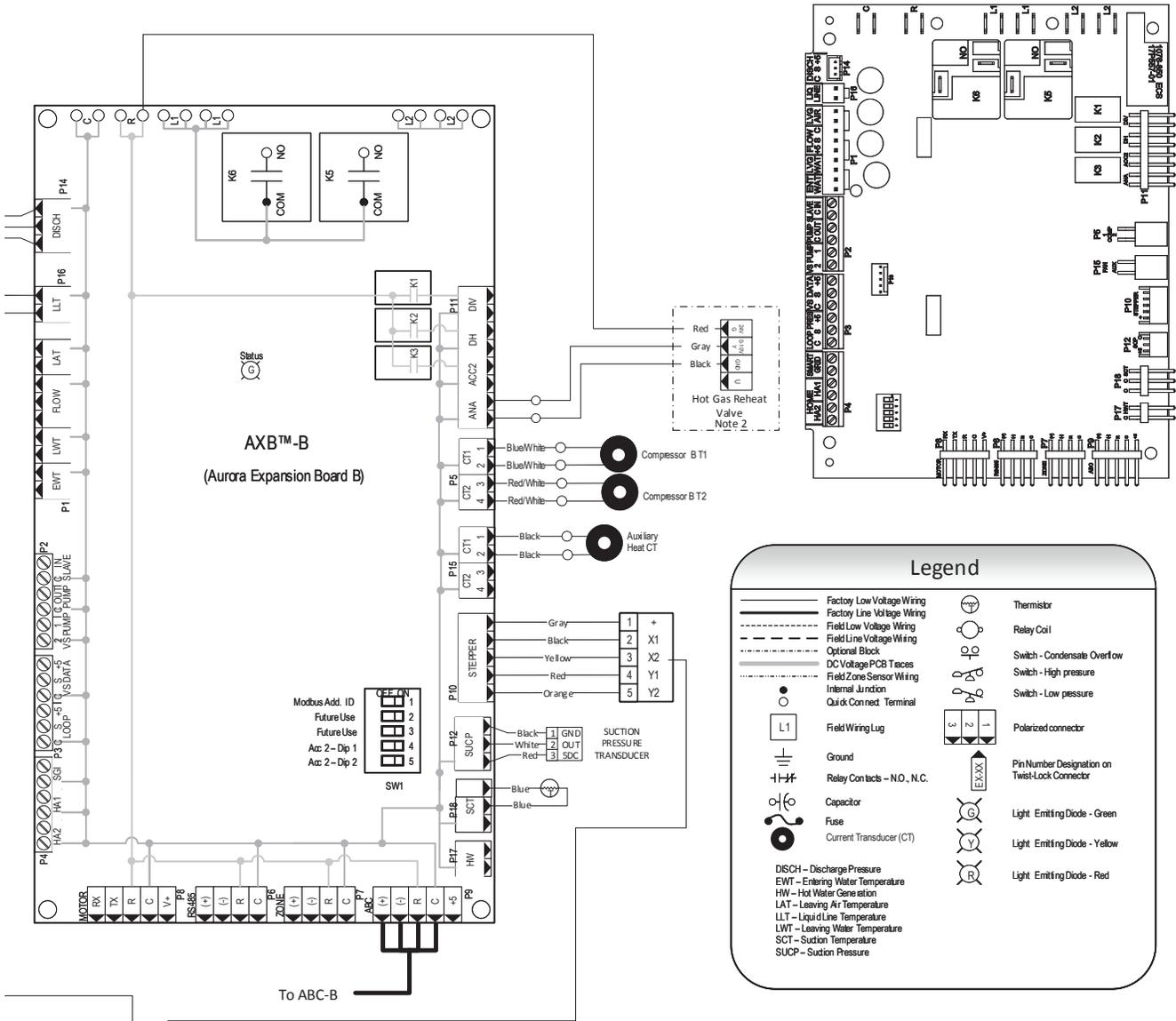

Aurora Timing Events		
Event	Normal Mode	Test Mode
Random Start Delay	5 to 80 seconds	1 second
Compressor On Delay	5 seconds	< 1 second
Compressor Minimum On Time	2 minutes	5 seconds
Compressor Short Cycle Delay	4 minutes	15 seconds
Blower Off Delay	30 seconds	2 seconds
Blower On Delay - High Pressure	Less than 1 second	Less than 1 second
Start-Up Bypass - Low Pressure	2 minutes	30 seconds
Fault Reason On Delay - Low Pressure	30 seconds	30 seconds
Start-Up Bypass - Low Water/Air Coil Limit	2 minutes	30 seconds
Fault Reason On Delay - Low Water/Air Coil Limit	30 seconds	30 seconds
Fault Reason On Delay - Condensate Overflow	2 seconds	2 seconds
Thermostat Call Recognition Time	5 minutes	20 seconds
Auxiliary Heat Staging Delay	2 minutes	7.5 seconds
Water Valve Slow Open Delay	90 seconds	90 seconds
Reheat Delay	30 seconds	30 seconds

Aurora LED Flash Codes			
Slow Flash	1 second on and 1 second off		
Fast Flash	100 milliseconds on and 100 milliseconds off		
Flash Code	100 milliseconds on and 400 milliseconds off with a 2 second pause before repeating		
Random Start Delay			
Status LED (LED3, Green)	Fast Flash		
Configuration LED (LED2, Yellow)	Fast Flash		
Fault LED (LED1, Red)	Fast Flash		
Status LED (LED3, Green)		Configuration LED (LED2, Yellow)	
Normal Mode	ON	No Software Override	Flash ECM Setting
Control is Non-Functional	OFF	DIP Switch Override	Slow Flash
Test Mode	Slow Flash	ECM Configure Mode	Fast Flash
Lockout Active	Fast Flash	Reset Configure Mode	Off
Dehumidification Mode	Flash Code 2		Low Air Coil Limit Lockout - FP2
Resealed	Flash Code 3		Low Water Coil Limit Lockout - FP1
Resealed	Flash Code 4		Loss of Charge Lockout
Load Shed	Flash Code 5		Condensate Overflow Lockout
ESP	Flash Code 6		Over/Under Voltage Shutdown
Resealed	Flash Code 7		Compressor Monitor Lockout
			Air/Water Coil Limit Sensor Error

Wiring Schematics cont.

Single Compressor 575/60/3

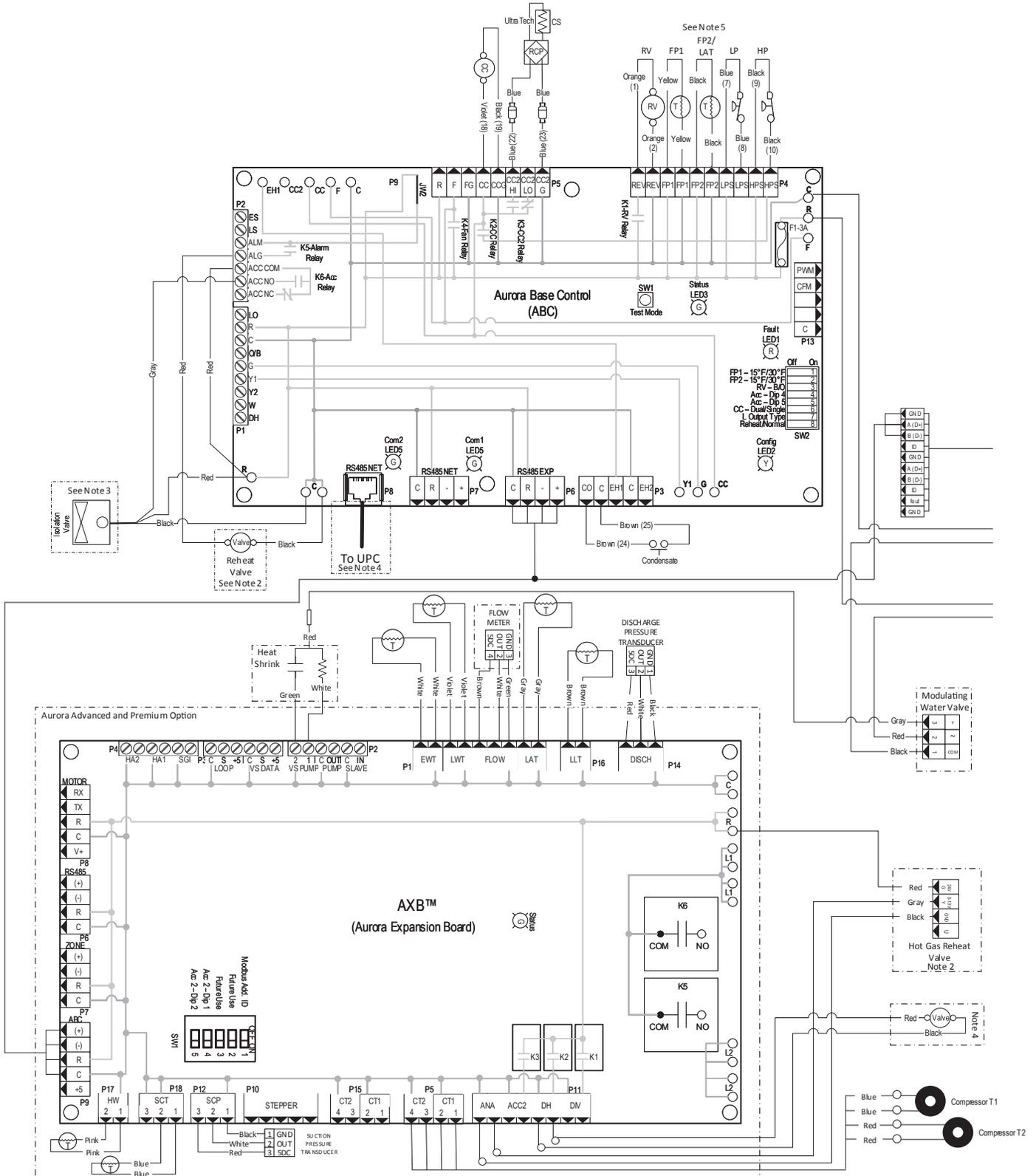

Wiring Schematics cont.

Single Compressor 575/60/3

3105500
03/01/21

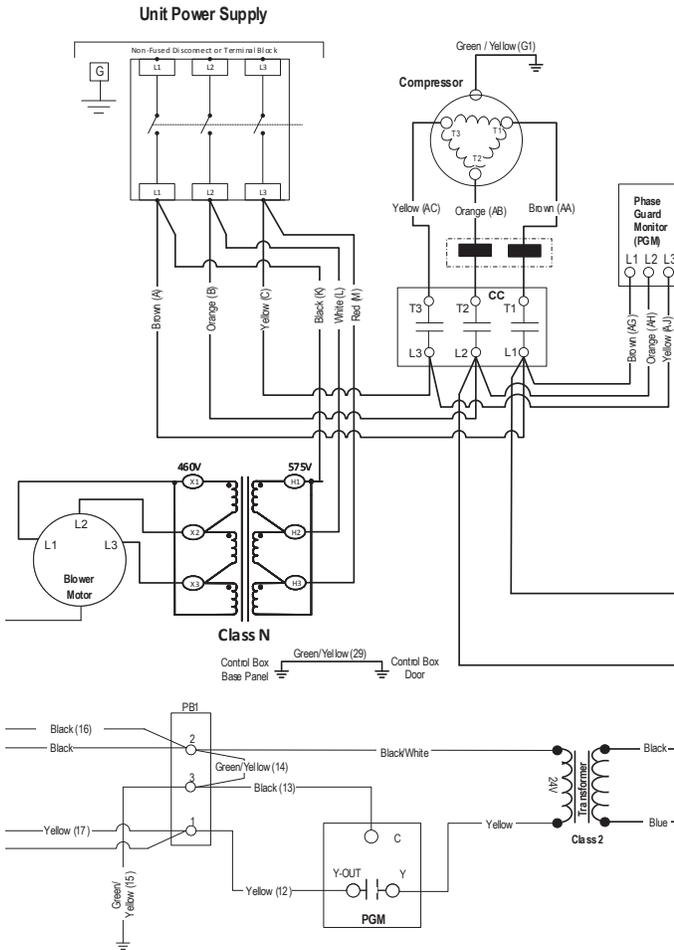

Aurora LED Flash Codes		
Slow Flash	1 second on and 1 second off	
Fast Flash	100 milliseconds on and 100 milliseconds off	
Flash Code	100 milliseconds on and 400 milliseconds off with a 2 second pause before repeating	
Random Start Delay		
Status LED (LED3, Green)	Fast Flash	
Configuration LED (LED2, Yellow)	Fast Flash	
Fault LED (LED1, Red)	Fast Flash	
Status LED (LED3, Green)	Configuration LED (LED2, Yellow)	Fault LED (LED1, Red)
Normal Mode	ON	No Software Override
Control is Non-Functional	OFF	Flash EOM Setting
Test Mode	Slow Flash	ECM Configure Mode
Lockout/Active	Fast Flash	Reset Configure Mode
Dehumidification Mode	Flash Code 2	Low Air Coil Limit Lockout - FP2
Reserved	Flash Code 3	Low Water Coil Limit Lockout - FP1
Reserved	Flash Code 4	Loss of Charge Lockout
Load Shed	Flash Code 5	Condensate Overflow Lockout
ESD	Flash Code 6	Over/Under Voltage Shutdown
Reserved	Flash Code 7	Reserved
		Compressor Monitor Lockout
		Air/Water Coil Limit Sensor Error
		Flash Code 11

Operation	Accessory Relay	SW2-1	SW2S
Cycle with Blower	On	On	
Cycle with Compressor	Off	Off	
Water Valve Slow Open	On	Off	
Outdoor Air Damper	Off	On	

Aurora Timing Events			
Event	Normal Mode	Test Mode	
Random Start Delay	5 to 80 seconds	1 second	
Compressor On Delay	5 seconds	< 1 second	
Compressor Minimum On Time	2 minutes	5 seconds	
Compressor Short Cycle Delay	4 minutes	15 seconds	
Blower Off Delay	30 seconds	2 seconds	
Fault Recognition Delay - High Pressure	Less than 1 second	Less than 1 second	
Start-Up Bypass - Low Pressure	2 minutes	30 seconds	
Fault Recognition Delay - Low Pressure	30 seconds	30 seconds	
Start-Up Bypass - Low Water/Air Coil Limit	2 minutes	30 seconds	
Fault Recognition Delay - Low Water/Air Coil Limit	30 seconds	30 seconds	
Fault Recognition Delay - Condensate Overflow	30 seconds	30 seconds	
Thermostat Call Recognition Time	2 seconds	2 seconds	
Auxiliary Heat Staging Delay	5 minutes	20 seconds	
Emergency Heat Staging Delay	2 minutes	7.5 seconds	
Water Valve Slow Open Delay	90 seconds	90 seconds	
Reheat Delay	30 seconds	30 seconds	

Notes:

- 1 - P1 (screw terminals) and P9 (Molex connector) are adjacent and share common terminals in the same order.
- 2 - Optional factory installed hot gas reheat.
- 3 - Optional factory installed internal isolation valve.
- 4 - See supplemental schematic for AXB and/or UPC connections.
- 5 - LAT location with Aurora Base Controls, FP2 with Aurora Advanced and Premium Controls.

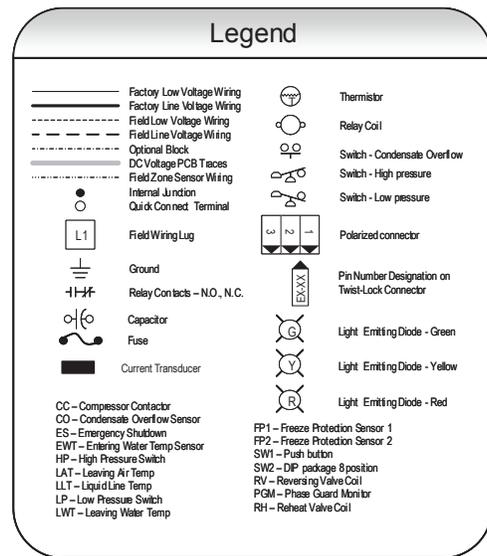
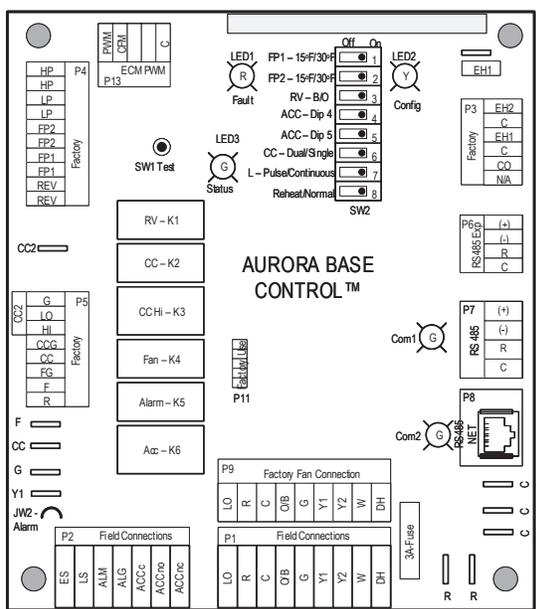

Wiring Schematics cont.

Dual Compressor Aurora Base 575/60/3

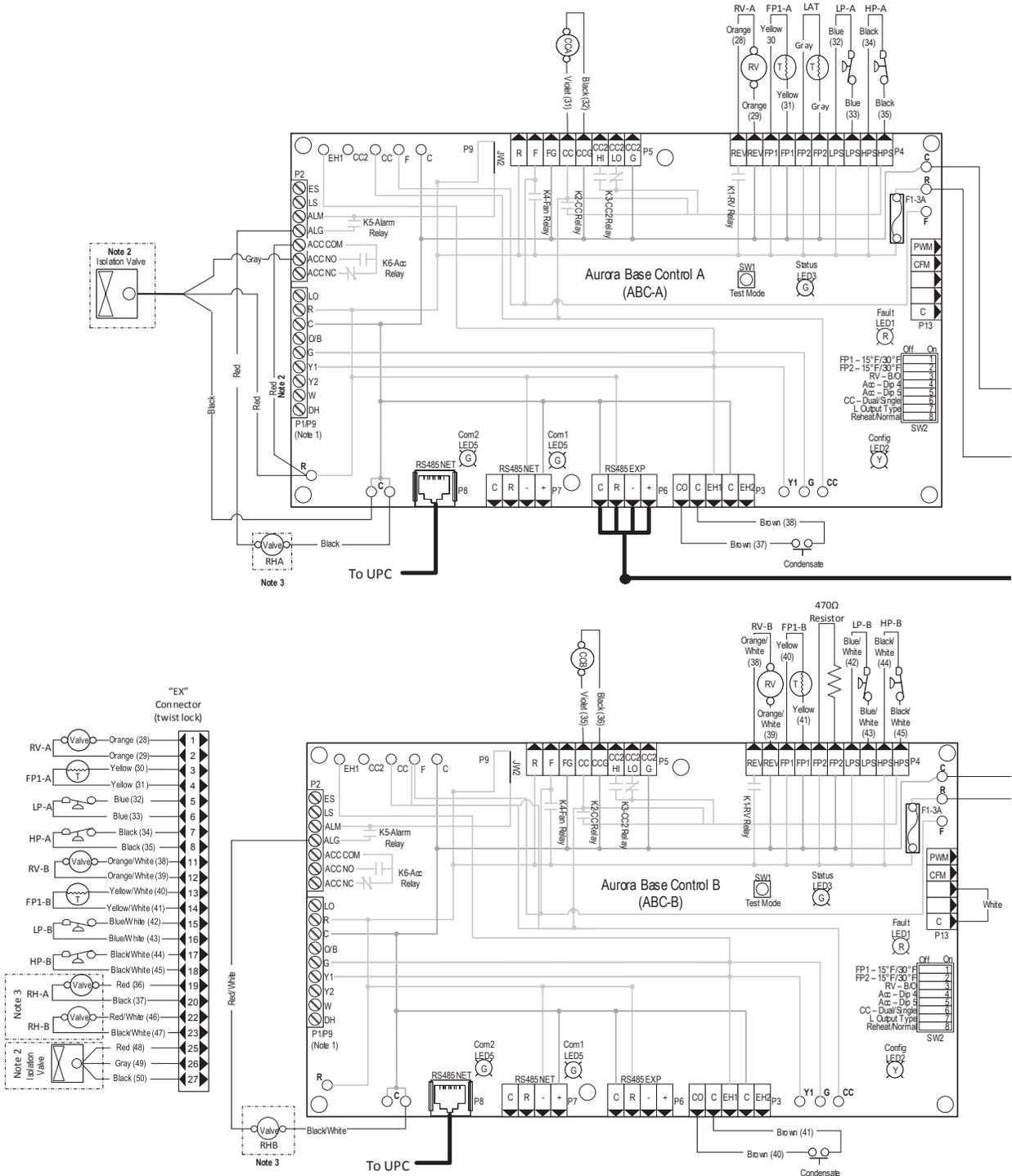

Wiring Schematics cont.

Dual Compressor Aurora Base 575/60/3

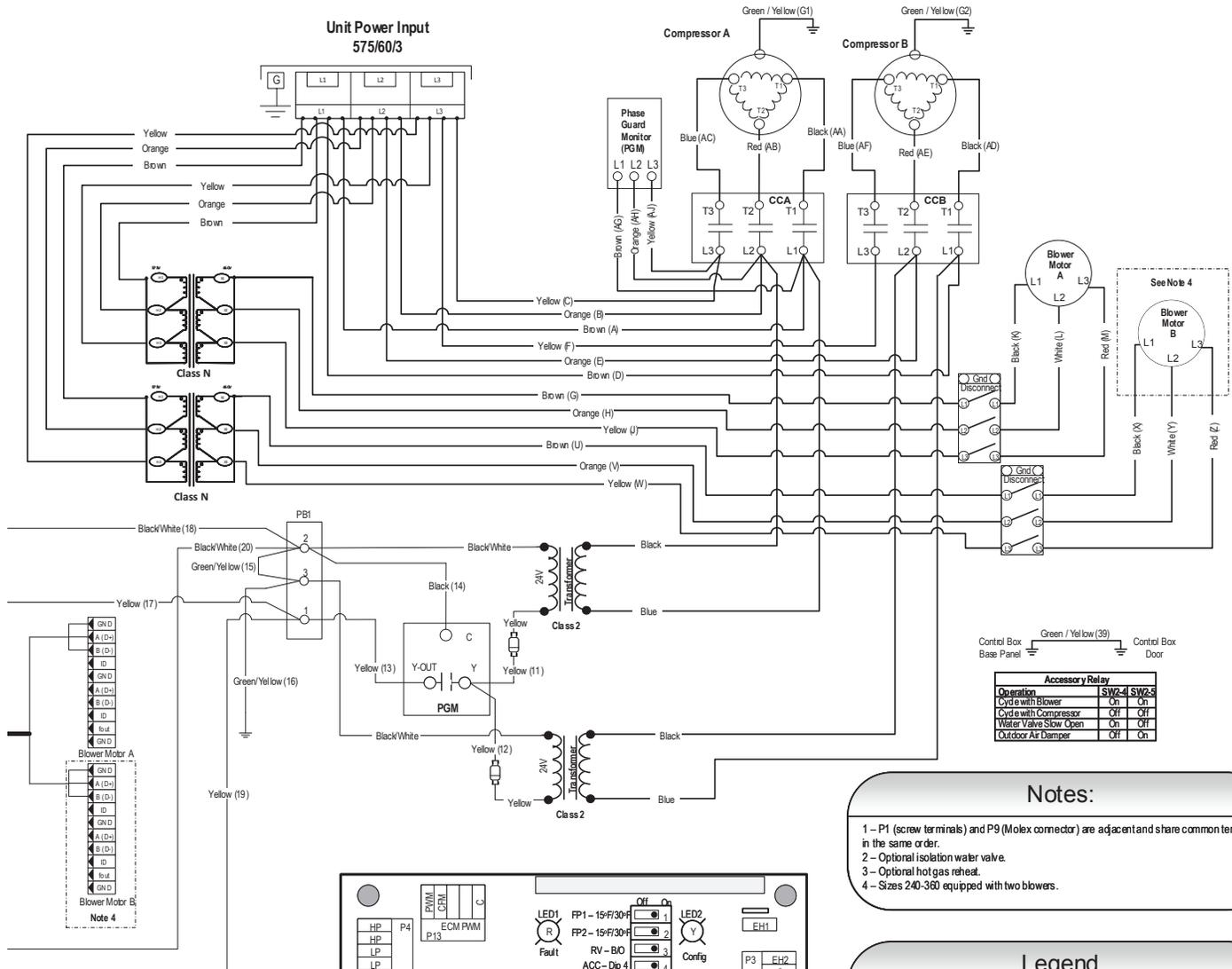

Notes:

- 1 - P1 (screw terminals) and P9 (Molex connector) are adjacent and share common terminals in the same order.
- 2 - Optional isolation water valve.
- 3 - Optional hot gas reheat.
- 4 - Sizes 240-360 equipped with two blowers.

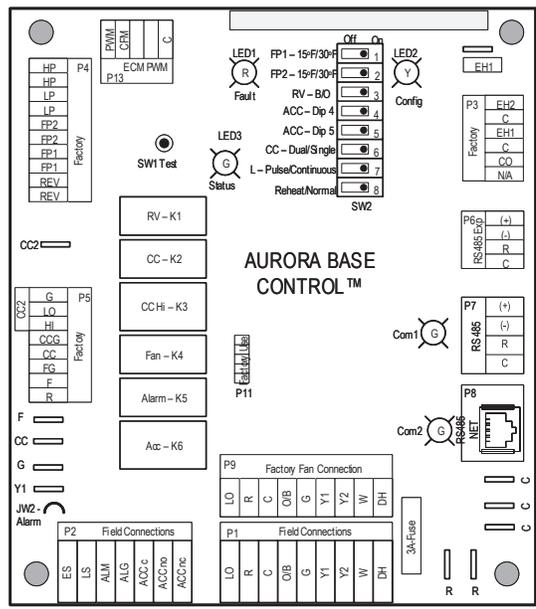

Legend

- Factory Low Voltage Wiring
- Factory Line Voltage Wiring
- Field Low Voltage Wiring
- Field Line Voltage Wiring
- Optional Block
- DC Voltage PCB Traces
- Field Zone Sensor Wiring
- Internal Junction
- Quick Connect Terminal
- Field Wiring Lug
- Ground
- Relay Contacts - N.O., N.C.
- Capacitor
- Fuse
- Thermistor
- Relay Coil
- Switch - Condensate Overflow
- Switch - High pressure
- Switch - Low pressure
- Polarized connector
- Pin Number Designation on Twist-Lock Connector
- Light Emitting Diode - Green
- Light Emitting Diode - Yellow
- Light Emitting Diode - Red

CCA - Compressor A Contactor
 CCB - Compressor B Contactor
 CO - Condensate Over/low Sensor
 ES - Emergency Shutdown
 HP1 - High Pressure Switch 1
 HP2 - High Pressure Switch 2
 LP1 - Low Pressure Switch 1
 LP2 - Low Pressure Switch 2
 FP1 - Freeze Protection Sensor 1
 FP2 - Freeze Protection Sensor 2
 F1 - Fuse

SW1 - Push button
 SW2 - DIP package 8 position
 RV1 - Reversing Valve Coil 1
 RV2 - Reversing Valve Coil 2
 PGM - Phase Guard Monitor
 RH - Reheat Valve Coil

Wiring Schematics cont.

Dual Compressor Aurora Advanced and Premium 575/60/3

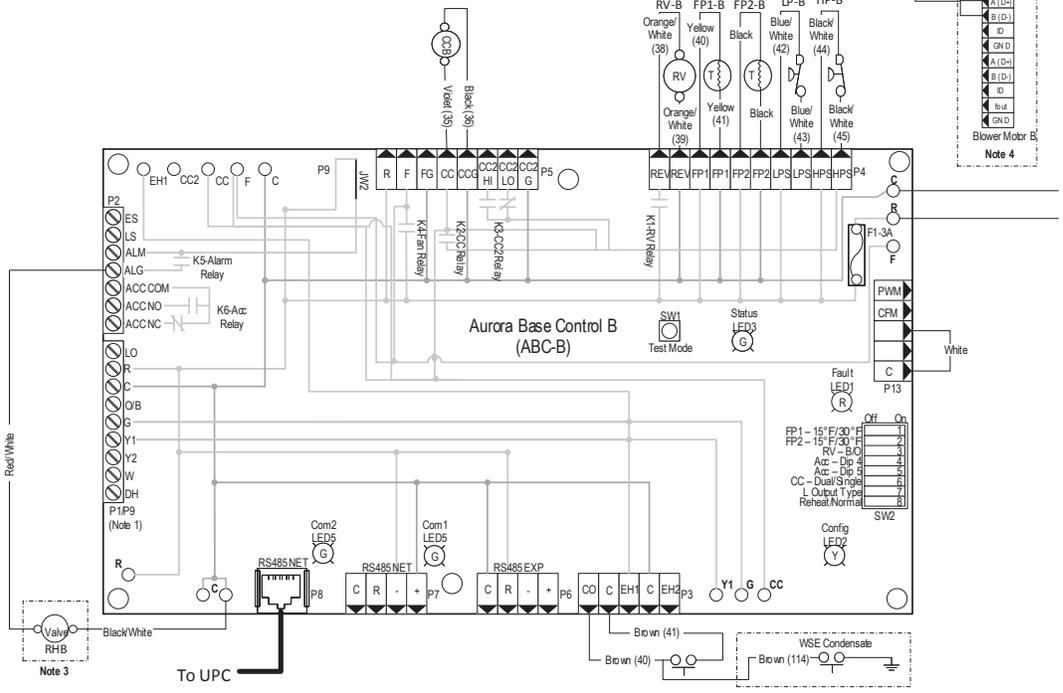
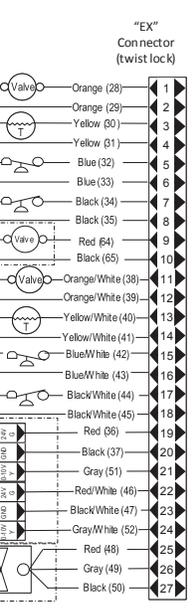
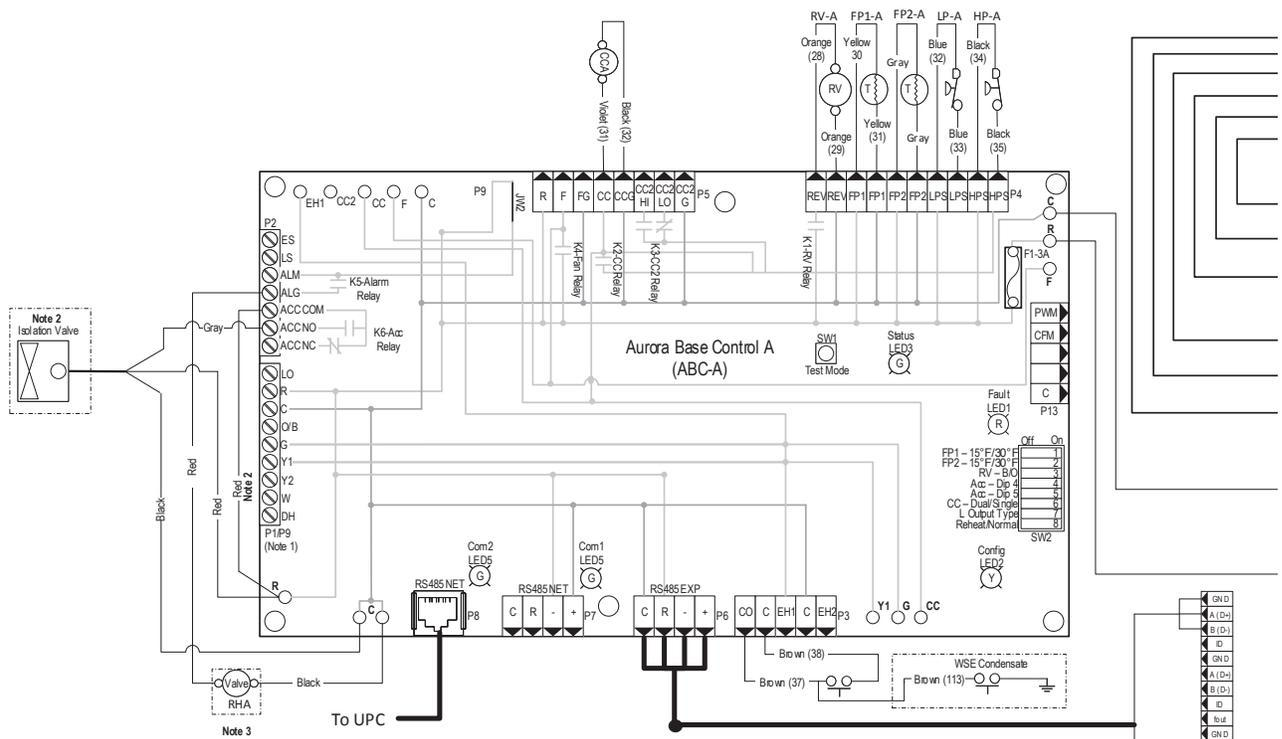

Wiring Schematics cont.

Dual Compressor Aurora Advanced and Premium 575/60/3

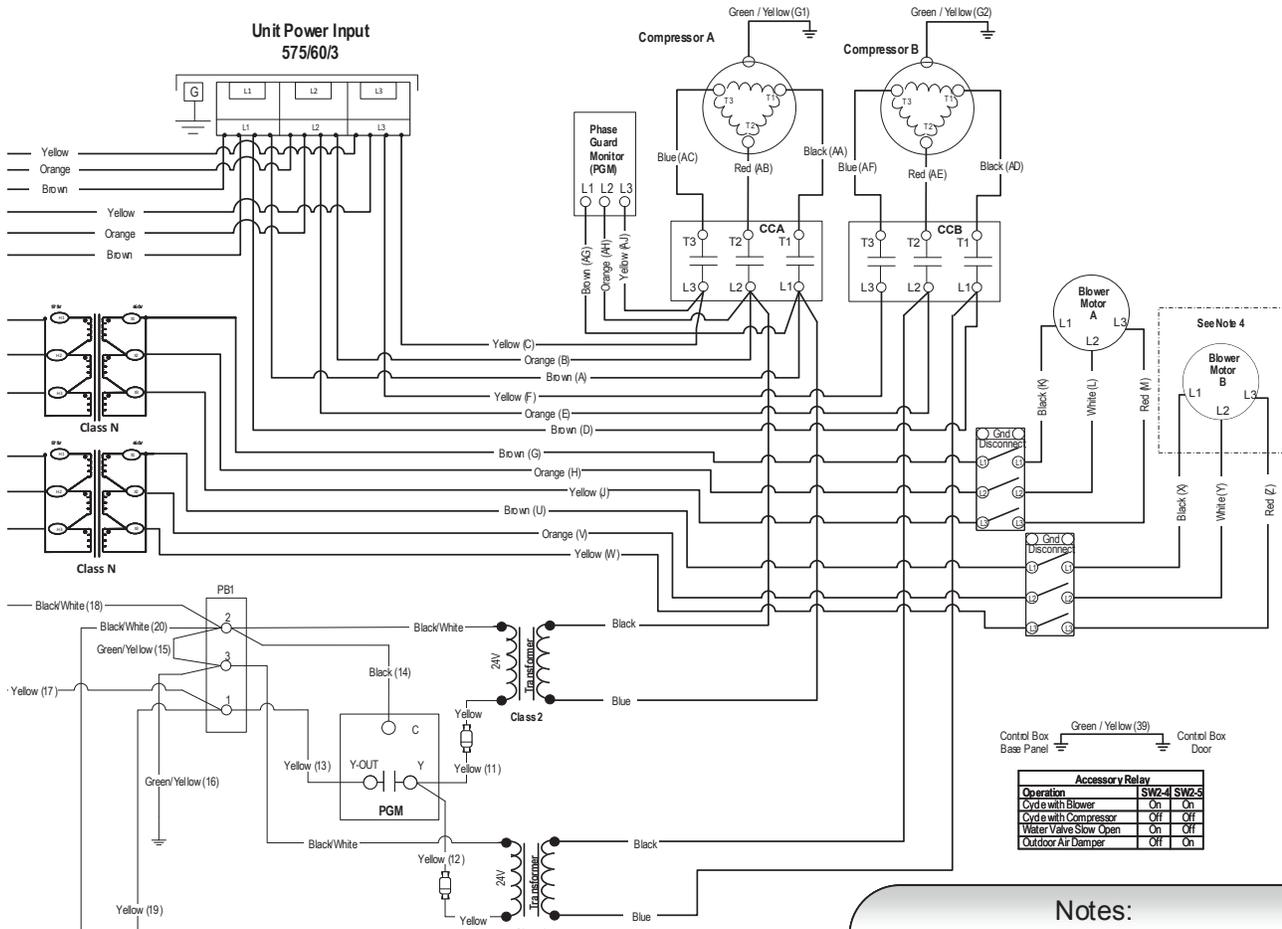

Accessory Relay		
Operation	SW2-1	SW2-2
Cycle with Blower	On	On
Cycle with Compressor	Off	Off
Water Valve Slow Open	On	Off
Outdoor Air Damper	Off	On

Notes:

- 1 – P1 (screw terminals) and P9 (Molex connector) are adjacent and share common terminals in the same order.
- 2 – Optional isolation water valve.
- 3 – Optional hot gas reheat.
- 4 – Sizes 240-360 equipped with two blowers.

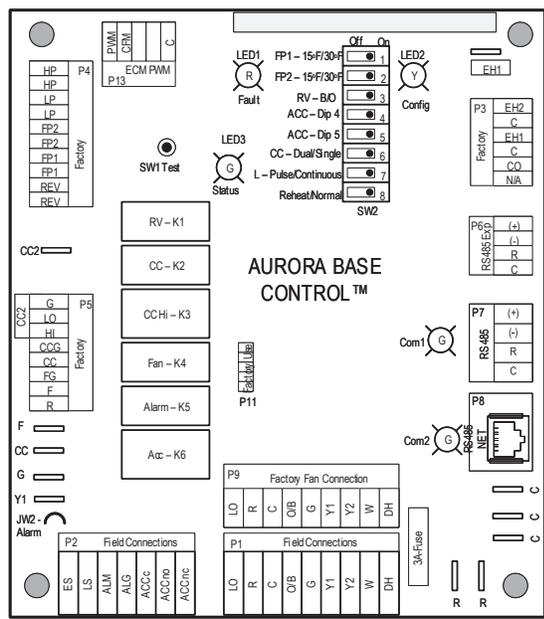

Legend

	Factory Low Voltage Wiring		Thermistor
	Factory Line Voltage Wiring		Relay Coil
	Field Low Voltage Wiring		Switch - Condensate Overflow
	Field Line Voltage Wiring		Switch - High pressure
	Optional Block		Switch - Low pressure
	DC Voltage PCB Traces		Polarized connector
	Field Zone Sensor Wiring		Pin Number Designation on Twist-Lock Connector
	Internal Junction		Light Emitting Diode - Green
	Quick Connect Terminal		Light Emitting Diode - Yellow
	Field Wiring Lug		Light Emitting Diode - Red
	Ground		SW1 - Push button
	Relay Contacts - N.O., N.C.		SW2 - DIP package 8 position
	Capacitor		RV1 - Reversing Valve Coil1
	Fuse		RV2 - Reversing Valve Coil2
	Current Transducer		PGM - Phase Guard Monitor
	CCA - Compressor A Contactor		RH - Reheat Valve Coil
	CCB - Compressor B Contactor		
	CO - Condensate Overflow Sensor		
	ES - Emergency Shutoff		
	HP1 - High Pressure Switch 1		
	HP2 - High Pressure Switch 2		
	LP1 - Low Pressure Switch 1		
	LP2 - Low Pressure Switch 2		
	FP1 - Freeze Protection Sensor 1		
	FP2 - Freeze Protection Sensor 2		
	F1 - Fuse		

Engineering Guide Specifications

General

Furnish and install Water Source Heat Pumps as indicated on the plans. Equipment shall be completely assembled, piped and internally wired. Capacities and characteristics as listed in the schedule and the specifications that follow. The reverse cycle heating/cooling units shall be either suspended type with horizontal air inlet and discharge or floor mounted type with horizontal air inlet and vertical upflow air discharge. Units shall be AHRI/ISO 13256-1 certified and listed by a nationally recognized safety-testing laboratory or agency, such as UL Testing Laboratory. Each unit shall be computer run-tested at the factory with conditioned water and operation verified to catalog data. Each unit shall be mounted on a pallet and shipped in a corrugated box or stretch-wrapped. The units shall be designed to operate with entering liquid temperature between 20°F and 120°F [-6.7°C and 48.9°C].

Casing and Cabinet

One (horizontal) to two (vertical) blower and two compressor compartment access panels shall be 'lift-out' removable with supply and return ductwork in place.

A duct collar shall be provided on the supply air opening. Standard size 2 in. [5.1 cm] MERV 4 filters shall be provided with each unit. Units shall have a return air filter rack that is field convertible from 1 in. [2.54 cm] to 2 in. [5.1 cm]. The upflow vertical units shall have a removable insulated divider panel between the air handling section and the compressor section to minimize the transmission of compressor noise and to permit operational service testing without air bypass. Vertical units shall be supplied with left or right horizontal air inlet and top vertical air discharge. Horizontal units shall be supplied with left or right air inlet and side or end air discharge.

Option: AlpinePure MERV 13 Filter - A 2 in. thick [51 mm] MERV 13 filter can help fulfill a credit under the LEED Rating System. Its low initial resistance promotes low energy consumption (0.21 in. w.g. @ 300 fpm) and provides nearly twice the life of a standard filter (300 fpm vs. standard 500 fpm application).

Option: A Super Quiet Sound package shall include multi-density full coverage compressor blanket.

Option: A field mounted low pressure drop (high Cv) water solenoid valve shall be factory installed for use in variable speed pumping applications.

Option: An internally mounted vortex shedding flow meter that uses MEMS technology with corrosion-resistant coating on the electronic chip to directly measure fluid flow. The sensor is in direct contact with the fluid and does not require any moving parts. Flow measurement is reportable through the BAS.

Option: An internally mounted 2-way modulating solenoid valve shall be factory installed and modulated by the Advanced Aurora Controls platform. Modulating percentage range is adjustable through the Aurora and the valve position is tied to compressor speed.

Compressors shall be high-efficiency permanent magnet motor, scroll type designed for variable capacity heat pump duty and mounted on vibration isolators. Compressors are matched to high-efficiency variable frequency drive (VFD) that communicate via ModBus to the Advanced Aurora Controls platform.

With vertical top/side discharge units, the condensate connection shall be a 3/4 in. [19.1 mm] PVC FPT fitting with internally-trapped hose that can be routed to front or side corner post locations. On horizontal and vertical bottom-flow units, a stainless steel 7/8" tube connects to a 3/4" MPT push to connect fitting. These units must be externally trapped.

Refrigerant Circuit

All units shall utilize the non-ozone depleting and low global warming potential refrigerant R-410A. All units shall contain a sealed refrigerant circuit including a hermetic motor-compressor, bidirectional electronic expansion valve, finned tube air-to-refrigerant heat exchanger, reversing valve, coaxial heat exchanger, and service ports.

The cabinet shall be fabricated from heavy-gauge galvanized steel and finished with optional corrosion-resistant powder coating. This corrosion protection system shall meet the stringent 1000 hour salt spray test per ASTM B117. The interior shall be insulated with 1/2 in. thick, multi-density, cleanable aluminum foil coated glass fiber with edges sealed or tucked under flanges to prevent the introduction of glass fibers into the discharge air. Standard cabinet panel insulation must meet NFPA 90A requirements, air erosion and mold growth limits of UL-181, stringent fungal resistance test per ASTM-C1071 and ASTM G21, and shall meet zero level bacteria growth per ASTM G22. Unit insulation must meet these stringent requirements or unit(s) will not be accepted.

Engineering Guide Specifications cont.

Option: AlumiSeal electro-coated air coil.

The coaxial water-to-refrigerant heat exchanger shall be designed for low water pressure drop and constructed of a convoluted copper (cupronickel option) inner tube and a steel outer tube. Refrigerant to air heat exchangers shall utilize enhanced corrugated lanced aluminum fins and rifled aluminum tube construction rated to withstand 600 psig (4135 kPa) refrigerant working pressure. Refrigerant to water heat exchangers shall be of copper inner water tube and steel refrigerant outer tube design, rated to withstand 600 psig (4135 kPa) working refrigerant pressure and 450 psig (3101 kPa) working water pressure. The thermostatic expansion valve shall provide proper superheat over the entire liquid temperature range with minimal "hunting." The valve shall operate bidirectionally without the use of check valves.

Option: ThermaShield coated water-to-refrigerant heat exchanger, water lines and refrigerant suction lines shall be insulated to prevent condensation at low liquid temperatures below 50°F.

Option: AlpinePure hot gas bypass

Blower Motor and Assembly

Supply fan shall be of single width, single inlet backward curved airfoil centrifugal fan design often referred to as a 'plenum fan'. The fan wheel shall be of Class II construction with aluminum fan blades that are continuously welded to the hub plate and end rim. The supply fan shall be a direct drive fan mounted to the motor shaft. Fan assembly shall be a slide out assembly for servicing and maintenance. All fan assemblies shall be statically and dynamically balanced at the factory. The fan motor shall be a high efficiency totally enclosed electronically commutated (EC) motor that is speed controlled by the Aurora controller. The motor shall include thermal overload protection and protect the motor in the case of excessive motor temperatures. The variable speed EC fan motor shall be soft starting and shall provide 12 cfm settings. The fan shall not operate in a state of surge at any point within the modulation range.

Electrical

A control box shall be located within the unit compressor compartment and shall contain a 75VA transformer, 24 volt activated, 2 pole compressor contactor, terminal block for thermostat wiring and solid-state controller for complete unit operation. Electromechanical operation WILL NOT be accepted. Units shall be name-plated for use with time delay fuses or HACR circuit breakers. Unit controls shall be 24 volt and provide heating or cooling as required by the remote thermostat/sensor.

An Aurora microprocessor-based controller that interfaces with a multi-stage electronic thermostat to monitor and control unit operation shall be provided. The control shall provide operational sequencing, blower speed control, high and low pressure switch monitoring, freeze detection, condensate overflow sensing, lockout mode control, LED status and fault indicators, fault memory, field selectable options and accessory output. The control shall provide fault retry three times before locking out to limit nuisance trips.

A detachable terminal block with screw terminals will be provided for field control wiring. All units shall have knockouts for entrance of low and line voltage wiring. The blower motor and control box shall be harness plug wired for easy removal.

Revision Guide

Pages:	Description:	Date:	By:
All	Document Creation	15 July 2021	JM



Product: Affinity **YDL Series**
Type: Geothermal/Water Source Heat Pumps
Size: 0.50-6 Ton

Document Type: Specification Catalog
Part Number: SC2770AK6
Release Date: 07/21