



Heating and Air Conditioning

SPECIFICATION CATALOG

AFFINITY

GEOHERMAL HEAT PUMPS

VARIABLE SPEED

MODELS:

YAFV036 - 060

(3 THRU 5 NOMINAL TONS)



Due to continuous product improvement, specifications are subject to change without notice.

Visit us on the web at www.york-geothermal.com

Additional rating information can found at www.ahridirectory.org

FOR DISTRIBUTION USE ONLY - NOT TO BE USED AT POINT OF RETAIL SALE

Table of Contents

Model Nomenclature	5
AHRI/ISO 13256-1 Performance Ratings	6
Affinity Variable Speed Series Design Features	8
The Aurora™ Advanced VS Control System	12
Operation Logic	21
Water Quality	22
Dimensional Data	23
Physical Data	27
Auxiliary Heat Ratings	28
Auxiliary Heat Electrical Data	28
Electrical Data	28
Blower Performance Data	29
Reference Calculations	30
Legend and Notes	30
Operating Limits	30
Antifreeze Corrections	31
Pressure Drop	32
Correction Factor Tables	33
Performance Data	34
Wiring Schematics	40
Engineering Guide Specifications	44
Revision Guide	47

AFFINITY™ SERIES

Variable Speed Geothermal Heat Pump



The York Affinity Variable Speed Series is a new level of innovation and performance with all new advanced controls mated with variable speed compressor technology. Featuring the highest efficiencies (Over 40 EER and 5.3 COP ISO/AHRI 13256-1 GLHP) available in AHRI, the Affinity Series is available in 3 variable speed capacity sizes (3 to 5 ton) with Danfoss Variable Speed Compressors. These units feature high efficiency permanent magnet compressors coupled with high efficiency electronic drives to allow capacity ranges between 20 and 100%. These Affinity Variable Speed Series units utilize ozone-safe R-410A refrigerant to meet the most stringent EPA requirements. Double epoxy electro-coated air coils add durability and longer life. Variable Speed ECM blowers are used to increase comfort, efficiency, and airflow flexibility.

A new sophisticated Aurora™ Control system is modular and designed for the most demanding application. The Aurora Control features a microprocessor control to sequence all components during operation for optimum performance. Plus, it provides easy-to-use troubleshooting features with fault lights, on-board diagnostics, and a hand held Aurora Interface Diagnostic (AID) Tool. The Aurora system includes advanced loop and hot water generator pump control, as well as service, performance, and energy monitoring sensor kit capability. A swing-out control box provides serviceability. Unit configurations include vertical top, bottom, or rear discharge (left or right return) and horizontal units with left or right return and side or end discharge. Heavy-gauge metal cabinets are fully insulated and coated with an attractive and durable paint for long lasting protection.

Affinity Variable Speed Series products are performance-certified to AHRI/ISO 13256-1 standards, ETL listed for safety, ENERGY STAR® qualified with ENERGY STAR Most Efficient qualifications, and tested in an ISO 17025 accredited testing lab.

As a leader in the industry, we are dedicated to innovation, quality, and customer satisfaction. In fact, every unit built is exposed to a wide range of quality control procedures throughout the assembly process in our ISO 9001:2008 certified manufacturing facility. At the end, it is subjected to a rigorous battery of computerized run tests to certify that it meets or exceeds performance standards for efficiency and safety, and will perform flawlessly at startup. As further affirmation of our quality standards, each unit carries our exclusive Quality Assurance emblem, signed by the final test technician.

Model Nomenclature

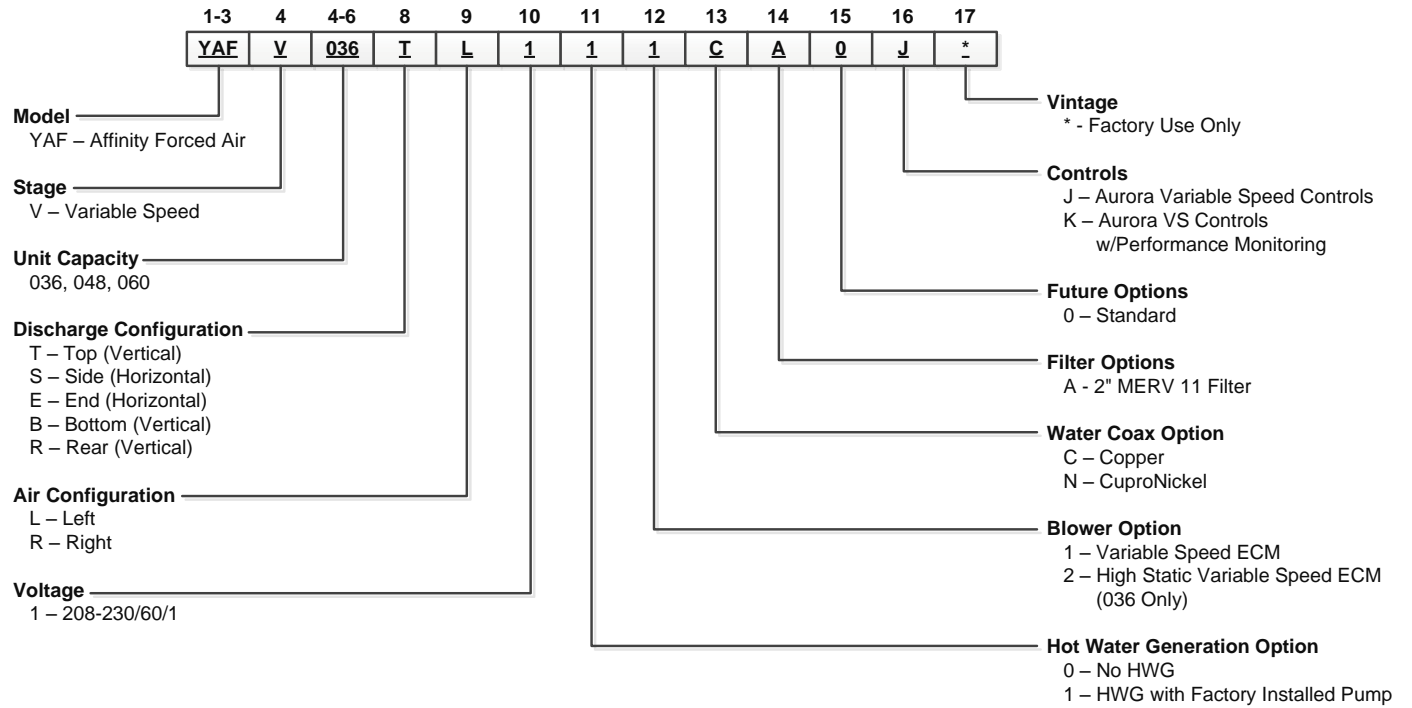

Rev.: 03 March 2015D

AHRI/ISO 13256-1 Performance Ratings

Variable Speed ECM Motor

AHRI/ASHRAE/ISO 13256-1
English (IP) Units

Model	Capacity Modulation	Airflow Clg/Htg CFM	Water Loop Heat Pump				Ground Water Heat Pump				Ground Loop Heat Pump			
			Cooling EWT 86°F		Heating EWT 68°F		Cooling EWT 59°F		Heating EWT 50°F		Cooling Full Load 77°F Part Load 68°F		Heating Full Load 32°F Part Load 41°F	
			Capacity Btu/h	EER Btu/h per W	Capacity Btu/h	COP	Capacity Btu/h	EER Btu/h per W	Capacity Btu/h	COP	Capacity Btu/h	EER Btu/h per W	Capacity Btu/h	COP
036	Full	1300/1500	32,000	18.0	50,000	5.3	38,000	31.5	41,000	4.6	36,000	22.0	32,000	3.5
	Part		11,000	21.0	17,000	7.5	13,000	47.2	14,000	5.9	14,000	37.0	13,000	5.3
048	Full	1500/1800	41,000	17.6	67,000	5.0	49,000	31.7	55,000	4.3	46,000	21.7	43,000	3.6
	Part		16,000	22.5	24,000	7.6	19,200	53.2	19,000	5.9	19,000	41.0	16,000	5.3
060	Full	1800/2200	50,000	16.3	78,000	4.8	60,000	28.6	65,000	4.3	56,000	19.4	51,000	3.5
	Part		20,000	21.7	29,000	7.5	23,200	45.8	23,000	6.0	23,000	36.0	20,000	5.1

Cooling capacities based upon 80.6°F DB, 66.2°F WB entering air temperature
Heating capacities based upon 68°F DB, 59°F WB entering air temperature
All ratings based upon 208V operation

6/15/12

Energy Star Compliance Table

Model	Tier 3	
	Ground Water	Ground Loop
036	Yes	Yes
048	Yes	Yes
060	Yes	Yes

6/1/12

Energy Star Rating Criteria

In order for water-source heat pumps to be Energy Star rated they must meet or exceed the minimum efficiency requirements listed below. Tier 3 represents the current minimum efficiency water source heat pumps must have in order to be Energy Star rated.

Tier 3: 1/1/2012 – No Effective End Date Published

Water-to-Air	EER	COP
Ground Loop	17.1	3.6
Ground Water	21.1	4.1
Water-to-Water		
Ground Loop	16.1	3.1
Ground Water	20.1	3.5



AHRI/ISO 13256-1 Performance Ratings cont.

The performance standard AHRI/ASHRAE/ISO 13256-1 became effective January 1, 2000 and replaces ARI Standards 320, 325, and 330. This new standard has three major categories: Water Loop (comparable to ARI 320), Ground Water (ARI 325), and Ground Loop (ARI 330). Although these standards are similar there are some differences:

Unit of Measure: The Cooling COP

The cooling efficiency is measured in EER (US version measured in Btu/h per Watt. The Metric version is measured in a cooling COP (Watt per Watt) similar to the traditional COP measurement.

Water Conditions Differences

Entering water temperatures have changed to reflect the centigrade temperature scale. For instance the water loop heating test is performed with 68°F (20°C) water rounded down from the old 70°F (21.1°C).

Air Conditions Differences

Entering air temperatures have also changed (rounded down) to reflect the centigrade temperature scale. For instance the cooling tests are performed with 80.6°F (27°C) dry bulb and 66.2°F (19°C) wet bulb entering air instead of the traditional 80°F (26.7°C) DB and 67°F (19.4°C) WB entering air temperatures. 80.6/66.2 data may be converted to 80/67 using the entering air correction table. This represents a significantly lower relative humidity than the old 80/67 of 50% and will result in lower latent capacities.

Pump Power Correction Calculation

Within each model, only one water flow rate is specified for all three groups and pumping Watts are calculated using the following formula. This additional power is added onto the existing power consumption.

- Pump power correction = (gpm x 0.0631) x (Press Drop x 2990) / 300

Where 'gpm' is waterflow in gpm and 'Press Drop' is the pressure drop through the unit heat exchanger at rated water flow in feet of head.

Blower Power Correction Calculation

Blower power is corrected to zero external static pressure using the following equation. The nominal airflow is rated at a specific external static pressure. This effectively reduces the power consumption of the unit and increases cooling capacity but decreases heating capacity. These Watts are significant enough in most cases to increase EER and COPs fairly dramatically over ARI 320, 325, and 330 ratings.

- Blower Power Correction = (cfm x 0.472) x (esp x 249) / 300

Where 'cfm' is airflow in cfm and 'esp' is the external static pressure at rated airflow in inches of water gauge.

ISO Capacity and Efficiency Calculations

The following equations illustrate cooling calculations:

- ISO Cooling Capacity = Cooling Capacity (Btu/h) + (Blower Power Correction (Watts) x 3.412)
- ISO EER Efficiency (W/W) = ISO Cooling Capacity (Btu/h) x 3.412 / [Power Input (Watts) - Blower Power Correction (Watts) + Pump Power Correction (Watt)]

The following equations illustrate heating calculations:

- ISO Heating Capacity = Heating Capacity (Btu/h) - (Blower Power Correction (Watts) x 3.412)
- ISO COP Efficiency (W/W) = ISO Heating Capacity (Btu/h) x 3.412 / [Power Input (Watts) - Blower Power Correction (Watts) + Pump Power Correction (Watt)]

Comparison of Test Conditions

	ARI 320	ISO/AHRI 13256-1 WLHP	ARI 325	ISO/AHRI 13256-1 GWHP	ARI 330	ISO/AHRI 13256-1 GLHP
Cooling						
Entering Air - DB/WB °F	80/67	80.6/66.2	80/67	80.6/66.2	80/67	80.6/66.2
Entering Water - °F	85	86	50/70	59	77	77
Fluid Flow Rate	*	**	**	**	**	**
Heating						
Entering Air - DB/WB °F	70	68	70	68	70	68
Entering Water - °F	70	68	50/70	50	32	32
Fluid Flow Rate	*	**	**	**	**	**

NOTES: * Flow rate is set by 10°F rise in standard cooling test

** Flow rate is specified by the manufacturer

Part load entering water conditions not shown

WLHP = Water Loop Heat Pump; GWHP = Ground Water Heat Pump; GLHP = Ground Loop Heat Pump

Conversions:

Airflow (lps) = cfm x 0.472;

WaterFlow (lps) = gpm x 0.0631;

ESP (Pascals) = ESP (in wg) x 249;

Press Drop (Pascals) = Press Drop (ft hd) x 2990

Affinity Variable Speed Design Features



- ① **VARIABLE SPEED COMPRESSOR:** High efficiency permanent magnet scroll compressor mated with high efficiency electronic drive providing 20-100% variable capacity, soft starting, ultra high efficiency, and lowest operating noise
- ② **DOUBLE ISOLATED COMPRESSOR:** Compressor is double isolation mounted to reduce noise and vibration
- ③ **AURORA ADVANCED VARIABLE SPEED CONTROLS & AID TOOL:** Aurora Controls with the AID Tool provide advanced service diagnostics; this device provides setup and configurations as well as real-time sensors for fault and lockout history, plus energy and refrigeration monitoring as standard features, that can all be monitored on the handheld AID Tool and much more
- ④ **OPTIONAL HOT WATER ASSIST:** Provides free hot water in cooling and very high efficiency hot water generation in heating mode
- ⑤ **COAXIAL HEAT EXCHANGER:** Standard large high efficiency copper (optional cupronickel) coax with our exclusive void-free and robotically applied ThermaShield™ insulation coating
- ⑥ **ELECTRONIC EXPANSION VALVE:** High efficiency bi-direction electronic expansion valve provides the ultimate in accurate control for the highest efficiency at any condition
- ⑦ **AIR COIL:** Large air coil is designed for maximum efficiency and moisture removal; exclusive double electro-coated for superior protection from formicary corrosion and patented 11 element fin design with rifled tubing
- ⑧ **DISCHARGE MUFFLER:** Helps quiet compressor gas pulsations
- ⑨ **ECM BLOWER MOTOR:** High efficiency and ultra-flexible ECM blower motors provide ultra-quiet operation
- ⑩ **FILTER RACK:** Filter rack holds 1 in. or 2 in. filters (field changeable) with exclusive snap on filter door
- ⑪ **FILTER:** High holding capacity 2 in. Pleated MERV 11 filter is standard and 4 in. pleated MERV 11 is optional
- ⑫ **SWIVEL LOOP CONNECTIONS:** Leak free swivel water connections provide a hand tight gasket connection that easily handles the temperature extremes of geothermal earth loops
- ⑬ **INSULATION:** Cleanable foil lined insulation to prevent mold growth; corrosion resistant composite drain pan
- ⑭ **CABINET FINISH:** Heavy gauge galvanized sheet metal cabinet has 1,000 hr. salt spray rated gray powder coat paint for long life
- ⑮ **ACCESS PANELS:** All access panels are lift out type for easier removal and servicing
- ⑯ **HINGED CONTROL BOX:** Hinged, swing out, removable control box
- ⑰ **HOT WATER GENERATOR SWITCH & AID TOOL PORT:** Hot water generator switch for easy enabling/disabling of the hot water generator pump; AID Tool port provides quick AID Tool connection
- ⑱ **CORROSION RESISTANT COMPOSITE DRAIN PAN**

Affinity Variable Speed Series Design Features cont.

Introducing the Affinity Variable Speed Series

- Highest AHRI/ISO 13256-1 Ratings.
 - Over 40 EER and 5.3 COP
- Latest technology compressors
 - High efficiency permanent magnet scroll compressor mated with high efficiency electronic variable speed drive providing 20-100% variable capacity, soft starting, ultra high efficiency and ultra low operating noise.
- ECM blower motor options
 - ECM blower motors for the highest in efficiency and airflow flexibility
- **Efficiency** – Variable speed compressor provides the highest AHRI Efficiencies and improved seasonal EER/COP for reduced energy use.
- **More Even Temperatures** – Nearly continuous operation results in more even temperatures in the home.
- **Soft Start Variable Speed Compressor** - VS Drive Soft Start provides quieter starting and operation with no 'light flicker' commonly associated with air conditioning or heat pumps. No GeoStart is required.
- **Quieter Operation** – Typical operation is at lower compressor speed, and resulting lower airflow means quieter operation.
- **Higher Heating Capacity** - The variable speed unit provides 20% higher heating capacity than comparable dual capacity or single speed compressor unit for reduced loop length and equipment size for a given cooling capacity.
- **'Active' Dehumidification** – In active dehumidification mode, the VS unit monitors the air coil conditions and adjusts compressor speed and airflow operation to maximize the moisture removal based upon a dehumidistat call from the thermostat for improved dehumidification.
- **'SuperBoost' Mode** - Occasionally there can be a requirement for a short term 'boost' of cooling capacity during a large party etc. The user can then select 'SuperBoost' mode on the thermostat which will allow the variable speed system to ramp up an extra 30% of cooling capacity if needed.
- **Communicating Digital Thermostats** - The Aurora controls system features either mono-chromatic or color touch screen graphic display thermostats for user interface with the variable speed system. These displays not only feature easy to use graphical interface but display alerts and faults in plain English.
- **Aurora Communicating Control Features**
 - Traditional Safety Sensors - HP, LP, condensate overflow, freeze detection loop, freeze detection air coil.
 - Variable Speed and EEV Watchdog Circuit - Drive control continually monitors the VS compressor for proper operation and digitally notifies the Aurora Control of any faults.
- Communicating Modular Design - Communicating modular design for flexibility and expandability.
- Intelligent hot water assist control - The Aurora control determines operation of hot water assist dependent upon system parameters to maximize overall system efficiency. Selectable hot water set points through the AID Tool.
- Electronic Expansion Valve for improved refrigerant control and high efficiency.
- **Loop Pump Linking** - for multiple units on one flow center with either variable speed, single, or dual capacity units. It even works with our legacy controls.
- **Electric Heat Powered Blower And Controls** - Provides emergency heat in the event of an open compressor circuit breaker.
- **Advanced Service Features**
 - Aurora Controls with the AID Tool provide advanced service diagnostics. With this device setup and configurations as well as real-time sensors, fault and lockout history can be monitored and much more. This device is required for setup and troubleshooting of the Affinity Series Unit.
 - The Affinity Series features refrigeration service sensors as a standard feature. Now superheat, subcooling, refrigerant pressures and various temperatures needed to diagnose unit problems are readily available at your finger tips in the AID Tool right out of the box.
 - Energy Monitoring - With this standard sensor kit installation, the Aurora Control will feature power monitoring of the compressor, blower, and electric heat. The information can be displayed on AID Tool, or selected thermostats.
 - Performance Monitoring (optional) - With this optional field or factory installed sensor kit, the Aurora controls can measure actual capacity and performance of the heat pump. The information can be displayed on the AID Tool.
 - Advanced communication to the VS drive with faults, electrical, and operational information for quick diagnosis.
- **Communicating Digital Thermostats** - The Aurora controls system features either mono-chromatic or color touch screen graphic display thermostats for user interface with the Affinity Series system. These displays not only feature easy to use graphical interface but display alerts and faults in plain English.
- **Cabinet Design** – Improved design of access panels, control box and filter rack.
- **Cabinet Configurations** – Top or rear air discharge for upflow or bottom discharge for counterflow installations in vertical units, side or end discharge for horizontal units.
- **Cupronickel Heat Exchanger**
- **High Static Blower Option** (3 ton only)

Affinity Variable Speed Design Features cont.

Application Flexibility

- Safe, efficient operation in a wide range of liquid temperatures (20°F to 120°F) and flow rates (as low as 1.5 gpm/ton in open loop applications when EWT >50°F)
- Top or rear air discharge for upflow or bottom discharge for counterflow installations in vertical units, side or end discharge for horizontal units
- True left or right return air locations—vertical and horizontal units include filter rack/duct collar
- Variable-speed ECM blowers permit various duct applications with flexible airflow selection
- Narrow cabinet for easy movement through doorways
- Internally trapped condensate piping on vertical units for neat, compact installation
- Optional field-installed auxiliary electric heater
- Corner-located electrical box for field wiring from two sides
- Circuit breaker protected loop pump power block for easy wiring
- 2 relays to control field-mounted accessories
- Field-selectable freeze detection setting for well or closed loop systems
- Loop pump linking feature allows multiple units to share one flow center (standard on variable speed systems)

Operating Efficiencies

- AHRI/ISO 13256-1 rating for heating COPs, cooling EERs, and low water flow requirements
- Optional hot water generator with internal pump generates hot water at considerable savings while improving overall system efficiency
- High-stability electronic expansion valve delivers optimum refrigerant flow over a wide range of conditions and provides bidirectional operation without troublesome check valves
- Efficient variable speed scroll compressors operate quietly
- Oversized coaxial tube water-to-refrigerant heat exchanger operates at low liquid pressure drops
- Convoluted copper water tube functions efficiently at low flow rates
- Oversized rifled copper tube/lanced aluminum fin air-to-refrigerant heat exchanger provides high efficiencies at low-face velocity with patented 11 element fin design
- Large, low-RPM blowers with ECM motors provide quiet and efficient air movement with high static capability
- Utilizes the ozone-friendly R-410A refrigerant which produces higher efficiencies and warmer discharge air temperatures

Service Advantages

- Hinged/removable control box for added serviceability
- Removable panels: three for the compressor compartment and one (on horizontals) or two (on verticals) for the air handling compartment to provide quick access to all internal components with ductwork in place
- Easily accessible electronic expansion valve

- Brass, swivel-type water connections for quick connection union, and elimination of wrenches and sealants during installation; sweat type connections are on the hot water generator
- Insulated divider and separate air handling/compressor access panels permit service testing without air bypass
- Designed for front access in tight applications
- LED fault and status lights on the Aurora board with memory for easy diagnostics
- Aurora AID Tool provides enhanced service information via communication directly with the Aurora control including sensor inputs, fault history, and much more
- Detachable thermostat connection strip for wiring convenience
- Hot water generator pump shut-off switch for easy startup and service
- Control box and blower motors have quick-attach wiring plugs for easy removal
- Internal drop-out blower with permanently-lubricated ball bearing motor
- Blower and transformer powered from auxiliary heat supply (when installed) to provide emergency heat with open compressor circuit breaker
- High and low pressure service ports in refrigerant circuit
- High and low pressure sensors as well as discharge, suction, heating/cooling liquid lines, EWT, LWT and LAT temperature sensors for ease of service via the AID Tool
- View subcooling and superheat on the AID Tool
- Energy monitoring is standard on the Affinity Series variable speed system; Easily check power consumption of the compressor, blower and auxiliary heat via the AID Tool or thermostat
- View heat of extraction/rejection on the AID Tool when the Performance option is installed

Product Quality

- Heavy-gauge steel cabinets are painted with durable powder coat paint for long lasting beauty and service
- Coaxial heat exchanger, refrigerant suction lines, hot water generator coil, and all water pipes are fully insulated to reduce condensation problems in low temperature operation
- All air coils are double electro-coated for extended life
- Noise reduction features include discharge muffler, double isolation mounted compressors and soft starting variable speed compressors and blower motors; insulated compressor compartment; interior cabinet insulation using 1/2 in. coated glass fiber; all units include compressor blanket for quiet operation
- Safety features include high-pressure, low-pressure, and loss of charge refrigerant controls to protect the compressor, condensate overflow protection, freeze detection sensor to safeguard the coaxial heat exchanger and air coil, blower start detection, hot water high-limit hot water generator pump shutdown, compressor monitoring, and fault lockout enables emergency heat and prevents compressor operation until thermostat or circuit breaker is reset

Affinity Variable Speed Design Features cont.

Microprocessor Benefits

- Communicating monochromatic or color digital auto-changeover thermostat with 3-stage heating/2-stage cooling holds precise temperature and provides varying blower speed control
- Component sequencing delays for quiet startup, shutdown, and timed staging of auxiliary electric heat
- ECM blower speed control provides higher supply air temperature in heating, better dehumidification in cooling, and quiet operation at reduced airflows in all modes
- Hot water limit prevents scalding, and pump shuts down automatically when full unit capacity is needed for heating
- Communication capability for future expansions

Options and Accessories

- **Communicating Digital Thermostats**
 - *Monochromatic Graphic Display Thermostats:* For user interface with the Aurora system; these displays not only feature easy to use graphical interface but display alerts and faults in plain English. When Energy Monitoring is added, instantaneous usage is displayed on the thermostat itself.
 - *Color Touch Screen Graphic Display Thermostats:* For user interface with the Aurora system; these displays not only feature easy to use graphical interface but display alerts and faults in plain English. When Energy Monitoring is added not only instantaneous usage is displayed but also weekly and annual consumptions are stored and graphed. Other features include full color implementation, user loaded background photos, and USB port for easy configuration and software updates.
- **Performance Monitoring Kit** - With this optional sensor kit installation, the Aurora controls can measure actual capacity and efficiency performance of the heat pump; the information can be displayed on the AID Tool.
- **IntelliZone2 Zone System** - The IntelliZone2 zoning system provides up to 6 zones (Variable Speed), 4 zones (Dual Capacity), or 2 zones (Single Speed) of individualized comfort via communication to the Aurora Control System.
- **AID Tool** - The Aurora Interface and Diagnostics (AID) Tool is a plug-in configuration and troubleshooting tool for the Aurora Control System.
- **Optional Cupronickel Heat Exchangers** - for open loop applications.
- **Optional Hot Water Generator** - with internally mounted pump and water heater plumbing connector.
- **Optional High Static ECM Blower Motor** - for high static applications (3 ton only).
- **24 Volt 1 in. Electronic Air Cleaner**
- **90% Efficient, Cleanable Electrostatic Filters**
- **Closed Loop Variable Speed Flow Center**
- **Closed Loop Variable Speed Non-Pressurized Flow Center**
- **Open Loop Modulating Water Valve**
- **Auxiliary Electric Heater**

- **Hose Kits**
- **Additional Accessory Relay**
- **Alpinepure 2 In. Merv 13 Filter**
- **Alpinepure 4 In. Merv 11 Filter**

Manufacturing Quality

- All units are computer run-tested, with conditioned source water, in all modes to ensure efficiency and reliability
- All refrigerant brazing is performed in a nitrogen atmosphere
- All units are deep evacuated to less than 150 microns prior to refrigerant charging
- All joints are helium leak-tested to ensure an annual leak rate of less than 1/4 ounce
- All major components bar coded; eliminating possibility of mismatched parts built into unit
- All assembly technicians thoroughly trained in proper quality procedures
- All units have model number and serial number embedded in control for local or remote retrieval
- Manufacturing facility is ISO 9001:2008 certified
- Engineering labs are ISO 17025 accredited

The Aurora™ Advanced VS Control System

Aurora Advanced VS Control

Aurora Advanced VS Control System is a complete residential and commercial comfort system that brings all aspects of the HVAC system into one cohesive module network. The Aurora Advanced VS Control features the Aurora Base Control (ABC) and the Aurora Expansion Board (AXB). The variable speed drive communicates to the Aurora Control and provides variable capacity and envelope control. The ABC features microprocessor control and HP, LP, loss of charge, condensate and freeze detection, over/under voltage faults, along with communicating thermostat capability for complete fault detection text at the thermostat. Aurora uses the Modbus communication protocol to communicate between

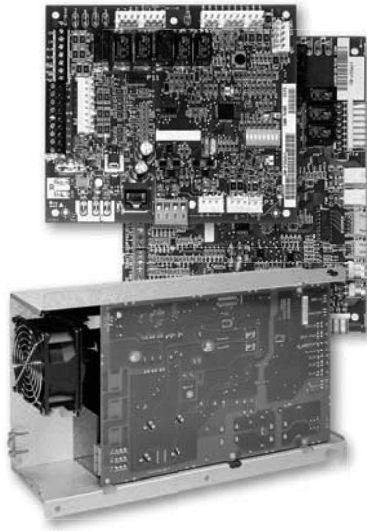

modules. Each module contains the logic to control all features that are connected to the module. The ABC has two Modbus channels. The first channel is configured for connecting to devices such as a communicating thermostat, expansion board, or other devices. The second channel is configured for connecting the Aurora Interface Diagnostics Tool (AID Tool).



The Aurora AXB expands on the capability of the ABC control board. The additional features include active dehumidification, SuperBoost cooling mode, loop pump linking, intelligent hot water generator control, variable speed pump capability, and also allows for optional energy, refrigeration, and performance monitoring add-on sensor kits. The AXB also features a second field configurable accessory relay, and two home automation inputs that are AID configurable for different types of alarms from sump pumps to home security. The Smart Grid input is AID configurable with many options to react to Utility controlled relay operation for On Peak optimization. The AXB also expands the communication capability for IntelliZone2 ready operation as well as other expansion with the ClimateTalk protocol.

Aurora Control Features	Description	Aurora Advanced VS
Advanced Microprocessor Features	Smart Grid, Home Automation Alarm Inputs, and Accessory2 Relay (HRV/ERV)	•
Advanced Hot Water Generator Control	Microprocessor and separate power relay for Hot Water Generator Pump with digital temperature monitoring and multiple HWG setpoint selection.	•
Advanced Speed Pump Control	Microprocessor and separate power relay for loop pump and inline circuit breakers and loop pump slaving.	•
Variable Speed Pump	Capable of setup, monitoring and controlling a variable speed flow center.	•
Active Dehumidification	Coil temperature is monitored and air flow is reduced for maximum latent moisture removal.	Affinity Variable Speed Only
SuperBoost	Allow the variable speed compressor to ramp up an extra 30% of cooling capacity if needed. This extra 'SuperBoost' will only be available for a 24 hr period and then the unit will revert to normal operation.	•
Smart Grid/Utility Input	Allows simple input to externally enable of occupied/unoccupied mode for basic utility time of use programs.	Dry Contact x1
Home Automation Alarm Input	Allows simple input to signal sump, security, or smoke/CO sensor alarms from other home automation or security systems. The two inputs can be field configured to a number of options and logic.	Dry Contact x2
IntelliZone2® Compatibility	IntelliZone2 communicates to the heat pump via the AXB board. IntelliZone requires traditional thermostat inputs and is not compatible with the Affinity Variable Speed Series.	Optional IntelliZone2

Service Device	Description	Aurora Advanced VS
 <p>Aurora Interface and Diagnostics (AID) Tool</p>	<p>Allows setup, monitoring and troubleshooting of any Aurora Control.</p> <p>NOTE: Although the ABC has basic compatibility with all Aurora, new product features may not be available on older AID Tools. To simplify the basic compatibility ensure the version of AID is at least the same or greater than the ABC software version.</p>	<p>For Service (Ver. 2.xx or greater)</p>

The Aurora Advanced VS Control System cont.

Add On Control Feature Kits (field or factory Installed)	Description	Aurora Advanced VS
Geo Energy Monitoring Kit	Monitors real time power consumption of compressor, blower, aux heat and pump. Requires thermostat TPCM32U04AYRK or TPCC32U01YRK.	Standard
Refrigeration Monitoring Kit	Monitors real time pressures, temperatures, superheat, and subcooling.	Standard
Performance Monitoring Kit	Monitors air and water temperatures, and water flow rate and calculates heat of extraction/rejection.	Optional Sensor Kit

Add On Thermostats and Zoning	Description	Aurora Advanced VS
 <p>TPCM32U04AYRK - MonoChrome Communicating Thermostat</p>	Elite Stat with full English fault codes and alerts, communicating thermostat; Monochrome thermostat allows instantaneous energy measurement only.	Optional
 <p>TPCC32U01YRK - Color Touchscreen Communicating Thermostat</p>	4.3 in. color touchscreen communicating thermostat with full English fault codes and alerts; Color thermostat allows instantaneous and 13 month history.	Optional
 <p>IntelliZone2® Zoning</p>	Includes color main thermostat and up to 6 zones (with variable speed), 4 zones (with dual capacity), and 2 zones (with single speed). There are 3 thermostat options (MasterStat, SensorStat, ZoneStat).	Optional

NOTES: The IntelliZone2 or one of the communicating thermostats shown above must be used to control the variable speed heat pump.

Aurora Advanced VS Control Features

NOTE: Refer to the Aurora Advanced VS Control Application and Troubleshooting Guide and the Instruction Guide: Aurora Interface and Diagnostics (AID) Tool for additional information.

Control Features

Software ABC VS Version 2.04W29 Variable Capacity Compressors

- Random start at power up
- Anti-short cycle protection
- High and low pressure cutouts
- Loss of charge
- Water coil freeze detection
- Air coil freeze detection
- Over/under voltage protection
- Condensate overflow sensor
- Load shed
- Dehumidification (where applicable)
- Emergency shutdown
- Diagnostic LED
- Test mode push button switch
- Two auxiliary electric heat outputs
- Alarm output
- Accessory output with N.O. and N.C.
- Modbus communication

Variable Speed ECM Blower Motor

A variable speed ECM blower motor is driven directly using the onboard PWM output. Multiple blower speeds are available based upon requirements of the compressor and electric heat. The blower speeds can be changed either by the variable speed ECM manual configurations mode method or by using the Aurora AID Tool directly.

Advanced Hot Water Generator Control (Domestic Hot Water Option)

An AID Tool selectable temperature limit and microprocessor control of the process is featured. This will maximize hot water generation and prevent undesirable energy use. An alert will occur when the hot water input temperature is at or above the set point (130°F default) for 30 continuous seconds. This alert will appear as an E15 on the AID Tool and the hot water pump de-energizes. Hot water pump operations resume on the next compressor cycle or after 15 minutes of continuous compressor operation during the current thermostat demand cycle.

Since compressor hot gas temperature is dependent on loop temperature in cooling mode, loop temperatures may be too low to allow proper heating of water. The control will monitor water and refrigerant temperatures to determine if conditions are satisfactory for heating water.

The Aurora Advanced VS Control System cont.

VS Drive and Envelope Control

The VS drive operates the compressor between 20 and 100% capacity. The VS drive communicates any out of refrigerant envelope conditions to the Aurora and will attempt to adjust the compressor speed to keep within the envelope. These conditions are measured using the discharge and suction pressure transducers, discharge temperature, and current sensors of the drive.

IntelliZone2 Zoning Compatibility (Optional IntelliZone2 Communicating Zoning)

A dedicated input to connect and communicate with the IntelliZone2 (IZ2) zoning system is provided on P7 on the AXB control board. There is a dedicated communication port using a proprietary ModBus protocol. The AXB is standard on variable speed systems. Consult the IntelliZone2 literature for more information.

Electronic Expansion Valve (EEV)

The electronic expansion valve is operated by the EEV board and is set to maintain optimal superheat setting for maximum efficiency. All operation parameters are communicated to the VS drive and the Aurora system.

Variable Speed Pump

This input and output are provided to drive and monitor a variable speed pump. The VS pump output is a PWM signal to drive the variable speed pump. The minimum and maximum level are set using the AID Tool. 50% and 100% are the default settings respectively. The VS data input allows a separate PWM signal to return from the pump giving fault and performance information. Fault received from the variable speed pump will be displayed as E16.

Modulating Water Valve

This output is provided to drive a modulating water valve. Through advanced design the 0-10VDC valve can be driven directly from the VS Pump output. The minimum and maximum level are set in the same way as the VS pump using the AID Tool. 50% and 100% are the default settings respectively.

Loop Pump Linking

This input and output are provided so that two units can be linked together with a common flow center. When either unit has a call for loop outputs, both unit's loop pump relays and variable speed pumps are energized. The flow center then can simply be wired to either unit. The output from one unit should be routed to the input of the other. If daisy chained, up to 16 heat pumps can be wired and linked together in this fashion.

Advanced Communication Ports

Communication ports P6 and P8 will provide future expansion via dedicated protocols. These are for future use.

Smart Grid/On Peak (SG) Input

The 'Smart Grid/On Peak' input was designed to allow utilities to utilize simple radio controlled switches to control the On Electric Peak behavior of the Affinity Series Geothermal Heat Pumps and provide demand reduction. With a closed contact signal, this input will limit the operation and thus the power consumption of the unit by disabling the compressor and electric heat as long as the signal is present. Code 7 will flash on the Green LED signifying the 'On Peak' mode. On Peak will also display on communicating thermostats.

Home Automation 1 and 2 Inputs

The Home Automation inputs are simple closed contact inputs that will trigger an AID Tool and thermostat alert for the homeowner. These would require optional sensors and or equipment for connection to the AXB board. With two inputs, two different sensors can be selected. The selected text will then be displayed on the AID Tool and communicating thermostats. These events will NOT alter functionality or operation of the heat pump/accessories and is for homeowner/service notification only.

Home Automation 1 - E23 HA1

With a closed dry contact signal, this input will cause an alarm and Alert Code 23 to indicate on the stat or flash on ABC.

The AID Tool will allow configuration of this input between the following selections:

- No Action
- Home Automation Fault [no lockout info only] - Output from home automation system
- Security Alarm [no lockout info only] - Output from home security
- Sump Alarm Fault [no lockout info only] - Switch output from sump sensor
- Smoke/CO Alarm Fault [no lockout info only] - Switch output from Smoke/CO sensor
- Dirty Filter Alarm [no lockout info only] - Output from dirty filter sensor

Home Automation 2 – E24 HA2

With a closed dry contact signal, this input will cause an alarm and Alert Code 24 to indicate on the stat or flash on ABC.

The AID Tool will allow configuration of this input between the following selections:

- No Action
- Home Automation Fault [no lockout info only] - Output from home automation system
- Security Alarm [no lockout info only] - Output from home security
- Sump Alarm Fault [no lockout info only] - Switch output from sump sensor
- Smoke/CO Alarm Fault [no lockout info only] - Switch output from Smoke/CO sensor
- Dirty Filter Alarm [no lockout info only] - Output from dirty filter sensor

The Aurora Advanced VS Control System cont.

Monitoring Sensor Kits

Energy Monitoring

(Standard on all Affinity Variable Speed Series units)

The Energy Monitoring Kit includes two current transducers (blower and electric heat) added to the existing compressor drive sensor so that the complete power usage of the heat pump can be measured. The AID Tool provides configuration detail for the type of blower motor and a line voltage calibration procedure to improve the accuracy. This information can be displayed on the AID Tool or selected communicating thermostats. The TPCM32U04AYRK will display instantaneous energy use while the color touchscreen TPCC32U01YRK will, in addition, display a 13 month history in graph form.

Refrigerant Monitoring

(Standard on all Affinity Variable Speed Series units)

The optional Refrigerant Monitoring Kit includes two pressure transducers, and three temperature sensors, heating liquid line, suction temperature and existing cooling liquid line (FP1). These sensors allow the measurement of discharge and suction pressures, suction and liquid line temperatures as well as superheat and subcooling. This information will only be displayed on the AID Tool.

Performance Monitoring

(Optional sensor kit)

The optional Performance Monitoring Kit includes three temperature sensors, entering and leaving water, leaving air temperature and a water flow rate sensor. With this kit heat of extraction and rejection will be calculated. This requires configuration using the AID Tool for selection of water or antifreeze.

Special Modes and Applications

Communicating Digital Thermostats

The Aurora VS controls system also requires either the monochromatic or color touch screen graphic display thermostats for user interface. These displays not only feature easy to use graphical interface but display alerts and faults in plain English.

'SuperBoost' Cooling Mode

Occasionally there can be a requirement for a short term 'boost' of cooling capacity during a large party etc. The Affinity Variable Speed Series allows the user to select 'SuperBoost' mode on the thermostat which will allow the Affinity Variable Speed Series VS to ramp up an extra 30% of cooling capacity if needed. This extra 'SuperBoost' will only be available for a 24 hr period and then the unit will revert to normal operation. The short term boost does not affect ground loop sizing since it is limited in operation. Continuous use of SuperBoost will result in overheating of the ground loop.

Dehumidification – Active

Active dehumidification will only activate during cooling operation and is based upon the humidity setpoint of the thermostat being at least 5% below the actual relative humidity and being within the temperature parameters described here. The green status LED will flash code 2 when active. The unit can operate a maximum of 1.5°F below the cooling setpoint. The compressor will ramp up and airflow will begin at a low level. Airflow is then reduced periodically until air coil temperature setpoint is reached. If coil temperature continues to drop, the airflow is increased until air coil setpoint is maintained. After 20 minutes of operation in the Active Dehumidification mode, normal cooling operation will resume for 5 minutes. This cycle continues until the dehumidification setpoint is reached, room temperature is more than 1.5°F below cooling setpoint, or more than 1°F above cooling setpoint (normal cooling takes over). In IntelliZone2 systems, active dehumidification is only enabled when system is operating on compressor speeds 4 or lower. Once active dehumidification is activated the main zone and any other active cooling zone will remain open.

Field Hardware Selectable Options

ABC Field Selectable Options via Button (SW1)

Test/Configuration Button (See SW1 Operation Table)

Test Mode

The control is placed in the test mode by holding the push button switch on the ABC SW1 for 2 - 5 seconds. In test mode most of the control timings will be shortened by a factor of sixteen (16). LED3 (green) will flash at 1 second on and 1 second off. Additionally, when entering test mode LED1 (red) will flash the last lockout one time. Test mode will automatically time out after 30 minutes. Test mode can be exited by pressing and holding the SW1 button for 2 to 5 seconds or by cycling the power. **NOTE:** Test mode will automatically be exited after 30 minutes.

Variable Speed ECM Configuration Mode

The control is placed in the variable speed ECM configuration mode by holding the push-button switch SW1 for 5 to 10 seconds, the high, low, and G variable speed ECM speeds can be selected by following the LED display lights. LED2 (yellow) will fast flash when entering the variable speed ECM configuration. When setting G speed LED3 (green) will be continuously lit, for low speed LED1 (red) will be continuously lit, and for high speed both LED3 (green) and LED1 (red) will be continuously lit. During the variable speed ECM configuration mode LED2 (yellow) will flash each of the 12 possible blower speeds 3 times. When the desired speed is flashed press SW1, LED2 will fast flash until SW1 is released. G speed has now been selected. Next select low speed, and high speed blower selections following the same process above. After third selection has been made, the control will exit the variable speed ECM configuration mode. Aux blower speed will remain at default or current setting and requires the AID Tool for adjustment.

The Aurora Advanced VS Control System cont.

Reset Configuration Mode

The control is placed in reset configuration mode by holding the push button switch SW1 on the ABC for 50 to 60 seconds. This will reset all configuration settings and the EEPROM back to the factory default settings. LED3 (green) will turn off when entering reset configuration mode. Once LED3 (green) turns off, release SW1 and the control will reset.

ABC DIP Switch (SW2)

- SW2-1** FP1 Selection – Low water coil temperature limit setting for freeze detection. On = 30°F; Off = 15°F.
- SW2-2** FP2 Selection – Low air coil temperature limit setting for freeze detection. On = 30°F; Off = Not Used
- SW2-3** RV – O/B - thermostat type. Heat pump thermostats with “O” output in cooling or “B” output in Heating can be selected. On = O; Off = B.
- SW2-4** Access Relay Operation (P2) and 2-5

Access Relay Operation	SW2-4	SW2-5
Cycle with Blower	ON	ON
Cycle with Compressor	OFF	OFF
Water Valve Slow Opening	ON	OFF
Cycle with Comm. T-stat Hum Cmd	OFF	ON

- SW2-6** CC Operation – selection of single or dual capacity compressor. On = Single Stage; Off = Dual Capacity
NOTE: SW2-6 is not applicable to the Affinity Variable Speed Series
- SW2-7** Lockout and Alarm Outputs (P2) – selection of a continuous or pulsed output for both the LO and ALM Outputs. On = Continuous; Off = Pulsed
NOTE: SW2-7 is not applicable to the Affinity Variable Speed Series
- SW2-8** Future Use

Alarm Jumper Clip Selection

From the factory, ALM is connected to 24 VAC via JW2. By cutting JW2, ALM becomes a dry contact connected to ALG.

Variable Speed ECM Blower Speeds

The blower speeds can be changed either by using the variable speed ECM manual configurations mode method or by using the Aurora AID Tool directly (see Instruction Guide: Aurora Interface and Diagnostics (AID) Tool topic).

AXB DIP Switch (SW1)

DIP 1 - ID: This is the AXB ModBus ID and should always read On.

DIP 2 & 3 - Future Use

DIP 4 & 5 - Accessory Relay2: A second, DIP configurable, accessory relay is provided that can be cycled with the compressor 1 or 2, blower, or the Dehumidifier (DH) input. This is to complement the Accessory 1 Relay on the ABC board.

Position	DIP 4	DIP 5	Description
1	ON	ON	Cycles with blower or ECM (or G)
2	OFF	ON	Cycles with CC1 first stage of compressor or compressor spd 1-12
3	ON	OFF	Cycles with CC2 second stage of compressor or compressor spd 7-12
4	OFF	OFF	Cycles with DH input from ABC board

Field Selectable Options via Software (Selectable via the Aurora AID Tool)

Many options are field selectable and configurable in Aurora software via the AID Tool. Consult the installation manual or Aurora documentation for further details.

Basic Aurora Safety Features

The following safety features are provided to protect the compressor, heat exchangers, wiring and other components from damage caused by operation outside of design conditions.

Fuse – a 3 amp automotive type plug-in fuse provides protection against short circuit or overload conditions.

Anti-Short Cycle Protection – 4 minute anti-short cycle protection for the compressor.

Random Start – 5 to 80 second random start upon power up.

Fault Retry – in the fault condition, the control will stage off the outputs and then “try again” to satisfy the thermostat VS call. Once the thermostat input calls are satisfied, the control will continue on as if no fault occurred. If 3 consecutive faults occur without satisfying the thermostat VS call, then the control will go to Lockout mode.

Lockout – when locked out, the blower will operate continuously in “G” blower speed setting. The Alarm output (ALM) and Lockout output (L) will be turned on. The fault type identification display LED1 (Red) shall flash the fault code. To reset lockout conditions with SW2-8 On, the demand call must be removed for at least 30 seconds. To reset lockout conditions with SW2-8 Off, the demand call must be removed for at least 30 seconds. Lockout may also be reset by turning power off for at least 30 seconds or by enabling the emergency shutdown input for at least 30 seconds.



CAUTION: Frequent cycling of power to the drive can damage the drive! Wait at least 5 minutes between cycles (connecting and disconnecting power to the drive).

The Aurora Advanced VS Control System cont.

Lockout With Emergency Heat - if the control is locked out in the heating mode, and a call for emergency heat is received, the control will operate in the emergency heat mode while the compressor is locked out. The first emergency heat output will be energized 10 seconds after the W input is received, and the blower will shift to high speed. If the control remains locked out, and the W input is present, additional stage of emergency heat will stage on after 2 minutes. When the W input is removed, all of the emergency heat outputs will turn off, and the variable speed ECM blower will shift to low speed.

High Pressure – fault is recognized when the Normally Closed High Pressure Switch, P4-9/10 opens, no matter how momentarily. The High Pressure Switch is electrically in series with the Compressor Contactor and serves as a hardwired limit switch if an overpressure condition should occur.

Low Pressure - fault is recognized when the Normally Closed Low Pressure Switch, P4-7/8 is continuously open for 30 seconds. Closure of the LPS any time during the 30 second recognition time restarts the 30 second continuous open requirement. A continuously open LPS shall not be recognized during the 2 minute startup bypass time.

Loss of Charge – fault is recognized when the Normally Closed Low Pressure Switch, P4-7/8 is open prior to the compressor starting.

Condensate Overflow - fault is recognized when the impedance between this line and 24 VAC common or chassis ground drops below 100K ohms for 30 seconds continuously.

Freeze Detection-Coax - set points shall be either 30°F or 15°F. When the thermistor temperature drops below the selected set point, the control shall begin counting down the 30 seconds delay. If the thermistor value rises above the selected set point, then the count should reset. The resistance value must remain below the selected set point for the entire length of the appropriate delay to be recognized as a fault. This fault will be ignored for the initial 2 minutes of the compressor run time.

Freeze Detection-Air Coil - Air Coil Freeze Detection will use the FP2 input to protect against ice formation on the air coil. The FP2 input will operate exactly like FP1 except that the set point is 30 degrees and is not field adjustable.

Over/Under Voltage Shutdown - An over/under voltage condition exists when the control voltage is outside the range of 18 VAC to 30 VAC. If the over/under voltage shutdown lasts for 15 minutes, the lockout and alarm relay will be energized. Over/under voltage shutdown is self-resetting in that if the voltage comes back within range of 18 VAC to 30 VAC for at least 0.5 seconds, then normal operation is restored.

Other Lockouts and Alarms

Several other lockouts and alarms are shown in the Status LED1 (LED1, Red) table with the associated codes visible on the thermostat, ABC Fault LED, and in text in the AID Tool.

Operation Description

Power Up - The unit will not operate until all the inputs and safety controls are checked for normal conditions. The unit has a 5 to 80 second random start delay at power up. Then the compressor has a 4 minute anti-short cycle delay after the random start delay.

Standby - In standby mode the compressor, pump, and blower motor are not active. The RV may be active. The blower and compressor will be off.

Heating Operation - The unit will operate based upon demand as calculated by the room setpoint algorithm. The resulting compressor speed (1-12) will also select an appropriate blower speed for the selected compressor speed. Aux Heat will not be available (on IntelliZone2 Aux Heat is available on compressor speeds 10-12) until after the 12th compressor speed has been operational and still is not satisfying the thermostat, then auxiliary electric heat will be activated.

Emergency Heat (W) - The blower will be started on G speed, 10 seconds later the first stage of electric heat will be turned on. 5 seconds after the first stage of electric heat is energized the blower will shift to Aux speed. If the emergency heat demand is not satisfied after 2 minutes the second electric heat stage will be energized.

Cooling Operation - The unit will operate based upon demand as calculated by the room setpoint algorithm. The resulting compressor speed, speeds 1-9, (speeds 10-12 are reserved for SuperBoost mode only) will also select an appropriate blower speed. The blower mode will also have the cooling airflow adjustment applied. In all cooling operations, the reversing valve directly tracks the O input. Thus, anytime the O input is present, the reversing valve will be energized.

Blower (G) - The blower will start immediately upon receiving a thermostat G command. If there are no other commands from the thermostat the variable speed ECM will run on low speed until the G command is removed. Regardless of blower input (G) from the thermostat, the blower will remain on low speed for 30 seconds at the end of each heating, cooling, and emergency heat cycle.

Emergency Shutdown - Four (4) seconds after a valid ES input, P2-7 is present, all control outputs will be turned off and remain off until the emergency shutdown input is no longer present. The first time that the compressor is started after the control exits the emergency shutdown mode, there will be an anti-short cycle delay followed by a random start delay. Input must be tied to common to activate.

The Aurora Advanced VS Control System cont.

Continuous Blower Operation - The blower output will be energized any time the control has a G input present, unless the control has an emergency shutdown input present. The blower output will be turned off when G input is removed.

Load Shed - The LS input disables all outputs with the exception of the blower output. When the LS input has been cleared, the anti-short cycle timer and random start timer will be initiated. Input must be tied to common to activate.

Aurora Advanced VS Control LED Displays

These three LEDs display the status, configuration, and fault codes for the control. These can also be read in plain English via the Aurora AID Tool. See the LED tables for further explanation.

Aurora Interface and Diagnostics (AID) Tool

The Aurora Interface and Diagnostics (AID) Tool is a device that is a member of the Aurora network. The AID Tool is used to troubleshoot equipment which uses the Aurora control via Modbus RTU communication. The AID Tool provides diagnostics, fault management, variable speed ECM setup, and system configuration capabilities



to the Aurora family of controls. An AID Tool is recommended, although not required, for variable speed ECM airflow settings. The AID Tool simply plugs into the exterior of the cabinet in the AID Tool port.

Status LED (LED3, Green)

Description of Operation	Fault LED, Green
Normal Mode	ON
Control is Non-functional	OFF
Test Mode	Slow Flash
Lockout Active	Fast Flash
Dehumidification Mode	Flash Code 2
Load Shed	Flash Code 5
Emergency Shutdown	Flash Code 6
On Peak Mode	Flash Code 7
Warning! VS Derated	Flash Code 8
Warning! VS SafeMode	Flash Code 9

Configuration LED (LED2, Yellow)

Description of Operation	Configuration LED, Yellow
No Software Overwritten	ECM Setting
DIP Switch Overwritten	Slow Flash
ECM Configuration Mode	Fast Flash
Reset Configuration Mode	OFF

The Aurora Advanced VS Control System cont.

Status LED (LED1, Red)	Red Fault LED	LED Flash Code	Lockout	Reset/Remove	Fault Condition Summary	ABC Action		AID Tool Display and History	IntelliZone2 and Thermostat Display	
						ABC Green Status LED	ABC Red Fault LED			
ABC & AXB Basic Faults	Normal - No Faults	Off	-							
	Fault-Input	1	No	Auto	Tstart input error. Autoreset upon condition removal.	Normal	Code 1			
	Fault-High Pressure	2	Yes	Hard or Soft	HP switch has tripped (>600 psi)	Lockout	Code 2	Lockout - E2 High Press	Lockout - E2 High Press	
	Fault-Low Pressure	3	Yes	Hard or Soft	Low Pressure Switch has tripped (<40 psi for 30 continuous sec.)	Lockout	Code 3	Lockout - E3 Low Press	Lockout - E3 Low Press	
	Fault-Freeze Detection FP2	4	Yes	Hard or Soft	Freeze protection sensor has tripped (<15 or 30 degF for 30 continuous sec.)	Lockout	Code 4	Lockout - E4 Freeze Detection FP2	Lockout - E4 Freeze Detection FP2	
	Fault-Freeze Detection FP1	5	Yes	Hard or Soft	Freeze protection sensor has tripped (<15 or 30 degF for 30 continuous sec.)	Lockout	Code 5	Lockout - E5 Freeze Detection FP1	Lockout - E5 Freeze Detection FP1	
	Fault-Condensate Overflow	7	Yes	Hard or Soft	Condensate switch has shown continuity for 30 continuous sec.	Lockout	Code 7	Lockout - E7 Condensate	Lockout - E7 Condensate	
	Fault-Over/Under Voltage	8	No	Auto	Instantaneous Voltage is out of range. **Controls shut down until resolved.	Lockout	Code 8	Lockout - E8 Over/Under voltage	Lockout - E8 Over/Under voltage	
	Fault-Compressor Monitor	10	Yes	Hard or Soft	Open Crkt. Run, Start or welded cont.	Lockout	Code 10	Lockout - E10 Compress Monitor	Lockout - E10 Compress Monitor	
	Fault-FP1 & 2 Snsr Error	11	Yes	Hard or Soft	If FP1 or 2 Sensor Error	Lockout	Code 11	Lockout - E11 FP1/FP2 Sensor Error	Lockout - E11 FP1/FP2 Sensor Error	
	Miscellaneous	Non-CritiCtAXBsnsrErr	13	No	Auto	Any Other Sensor Error	Normal	Code 13	Alert - E13 Non-Critical AXB Sensor Error	Alert - E13 Non-Critical AXB Sensor Error
		CritiCtAXBsnsrErr	14	Yes	Hard or Soft	Sensor Err for EEV or HW	Lockout	Code 14	Lockout - E14 Critical AXB Sensor Error	Lockout - E14 Critical AXB Sensor Error
		Alarm-HoWtr	15	No	Auto	HW over limit or logic lockout. HW pump deactivated.	Normal	Code 15	Alert - E15 Hot Water Temp Limit	No Display
Fault-VaSpdPump		16	No	Auto	Alert is read from PWM feedback.	Normal	Code 16	Alert - E16 Var Spd Pump Err	Alert - E16 Var Spd Pump Err	
Non-CritComErr		18	No	Auto	Any non-critical com error	Normal	Code 18	Alert - E18 Non-Critical Communication Error	Alert - E18 Non-Critical Communication Error	
Fault-CritComErr		19	No	Auto	Any critical com error. Auto reset upon condition removal	Normal	Code 19	Alert - E19 Critical Communication Error	Alert - E19 Critical Communication Error	
Alarm - Low Loop Pressure		21	No	Auto	Loop pressure is below 3 psi for more than 3 minutes	Normal	Code 21	Alert - E21 Selected choice	Alert - E23 Selected choice	
Alarm - Home Automation 1		23	No	Auto	Closed contact input is present on Dig 2 input - Text is configurable	Normal	Code 23	Alert - E23 Selected choice	Alert - E23 Selected choice	
Alarm - Home Automation 2		24	No	Auto	Closed contact input is present on Dig 3 input - Text is configurable	Normal	Code 24	Alert - E24 Selected choice	Alert - E24 Selected choice	
Derate-DriveTemp		41	No	Auto	Drive Temp has reached critical High Temp (>239 F/115 C)	Derated	Code 41	Warning/ Derated - E41 DriveTemp	Warning/ Derated - E41 DriveTemp	
Derate-HiDisTemp		42	No	Auto	Discharge temperature has reached critical high temp (> 280 F/138 C)	Derated	Code 42	Warning/ Derated - E42 HiDisTemp	Warning/ Derated - E42 HiDisTemp	
Derate-LoSucPres		43	No	Auto	Suction Pressure is critically low (< 28 psig)	Derated	Code 43	Warning/ Derated - E43 LoSucPres	Warning/ Derated - E43 LoSucPres	
Derate-LoConPres		44	No	Auto	Condensing pressure is critically low (< 119 psig)	Derated	Code 44	Warning/ Derated - E44 LoConPres	Warning/ Derated - E44 LoConPres	
Derate-HiConPres	45	No	Auto	Condensing pressure is critically high (> 654 psig)	Derated	Code 45	Warning/ Derated - E45 HiConPres	Warning/ Derated - E45 HiConPres		
Derate-OverPwrLmt	46	No	Auto	Supply Voltage is >280V or Max Pwr is reached due to high pressure	Derated	Code 46	Warning/ Derated - E46 OutPwrLmt	Warning/ Derated - E46 OutPwrLmt		
SafeMde-EEV/IndCom	47	No	Auto	Com with EEV is interrupted EEV has gone independent mode	SafeMode	Code 47	Warning/ SafeMode - E47 EEV/IndCom	Warning/ SafeMode - E47 EEV/IndCom		
SafeMde-EEV/OutCom	48	No	Auto	Com with EEV is interrupted EEV has gone independent mode	SafeMode	Code 48	Warning/ SafeMode - E48EEV/OutCom	Warning/ SafeMode - E48EEV/OutCom		
SafeMde-AmbTmPrSnr	49	No	Auto	Ambient Temperature (Tamb) is < 76 or > 212 F and out of range or invalid	SafeMode	Code 49	Warning/ SafeMode - E49	Warning/ SafeMode - E49		
Fault-DistTmPrSnr	51	Yes	Hard or Soft	Discharge Sensor (Sd) is > 280 F or invalid (76 to 392 F)	Lockout	Code 51	Lockout - E51 DistTmPrSnr	Lockout - E51 DistTmPrSnr		
Fault-SucPrsSnr	52	Yes	Hard or Soft	Suction Pressure (PO) is invalid (0 to 232 psi)	Lockout	Code 52	Lockout - E52 SucPrsSnr	Lockout - E52 SucPrsSnr		
Fault-ConPrsSnr	53	10x then Yes	Hard or Soft	Low condensing pressure (PD) or invalid (0 to 870 psi) Retry 10x.	Norm then Lockout	Code 53	Lockout - E53 ConPrsSnr	Lockout - E53 ConPrsSnr		
Fault-LowSup/Volt	54	Yes	Hard or Soft	Supply Voltage is <180 V (190V to reset) or powered off/on too quickly (<30 sec.)	Lockout	Code 54	Lockout - E54 LowSup/Volt	Lockout - E54 LowSup/Volt		
Dantress VS Drive	Fault-OutEnvelop	55	10x then Yes	Hard or Soft	Comp Operating out of envelope (PO) more than 90 sec. Retry 10x.	Norm then Lockout	Code 55	Lockout - E55 OutEnvelop	No Display	
	Fault-OverCurmt	56	Yes	Hard or Soft	Over current tripped by phase loss, earth fault, short circuit, low water flow, low air flow, or major drive fault.	Lockout	Code 56	Lockout - E56 OverCurmt	Lockout - E56 OverCurmt	
	Fault-Over/UnderVolt	57	Yes	Hard or Soft	DC Link Voltage to compressor is >450Vdc or at minimum voltage (<185Vdc).	Lockout	Code 57	Lockout - E57 Over/Under-Volt	Lockout - E57 Over/Under-Volt	
	Fault-HiDrvTemp	58	Yes	Hard or Soft	Drive Temp has reached critical High Temp >239 F	Lockout	Code 58	Lockout - E58HiDrvTemp	Lockout - E58HiDrvTemp	
	Fault-DrvIntErr MOC/AOC	59	Yes	Hard or Soft	The MOC has encountered an internal fault or an internal error. Probably fatal.	Lockout	Code 59	Lockout - E59 DrvIntErr	Lockout - E59 DrvIntErr	
	Fault-MultSafeMld	61	Yes	Hard or Soft	More than one SafeMode condition is present requiring lockout.	Lockout	Code 61	Lockout - E61 MultSafeMld	Lockout - E61 MultSafeMld	
	Fault-LossOfCharge	71	Yes	Hard or Soft	High superheat and high EEV opening % for a long time will trigger a loss of charge fault	Lockout	Code 71	Lockout - E71 LossCharge	Lockout - E71 LossCharge	
	SafeMde-SucTmPrSnr	72	No	Auto	Suction Temperature Sensor is invalid (<76 to 392 F)	SafeMode	Code 72	Warning/ SafeMode - E72 SucTmPrSnr	Warning/ SafeMode - E72 SucTmPrSnr	
	SafeMde-LATSensor	73	No	Auto	Leaving Air Temperature Sensor is invalid (<76 to 392 F)	Normal	Code 73	Alert - E73 LAT Sensor	No Display	
	SafeMde-MaxOpPres	74	No	Auto	Suction pressure has exceeded that maximum operating level for 90 sec.	SafeMode	Code 74	Warning/ SafeMode - E74 MaxOpPres	Warning/ SafeMode - E74 MaxOpPres	

NOTES: *All codes >11 use long flash for tens digit and short flash for the ones digit. 20, 30, 40, 50 etc. are skipped!
Alert is a noncritical sensor or function that has failed. **Normal operation of the heat pump is maintained but service is desired at some point.

The Aurora Advanced VS Control System cont.

ABC Control Board Layout

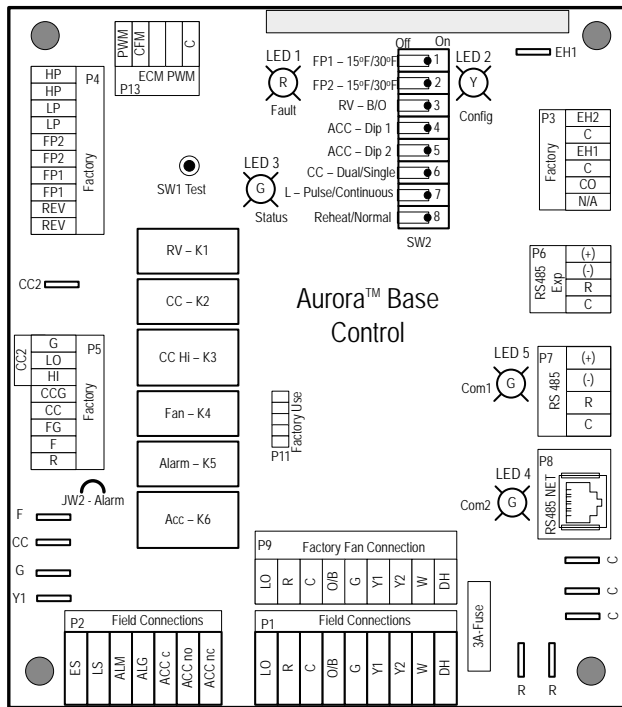

AXB Control Board Layout

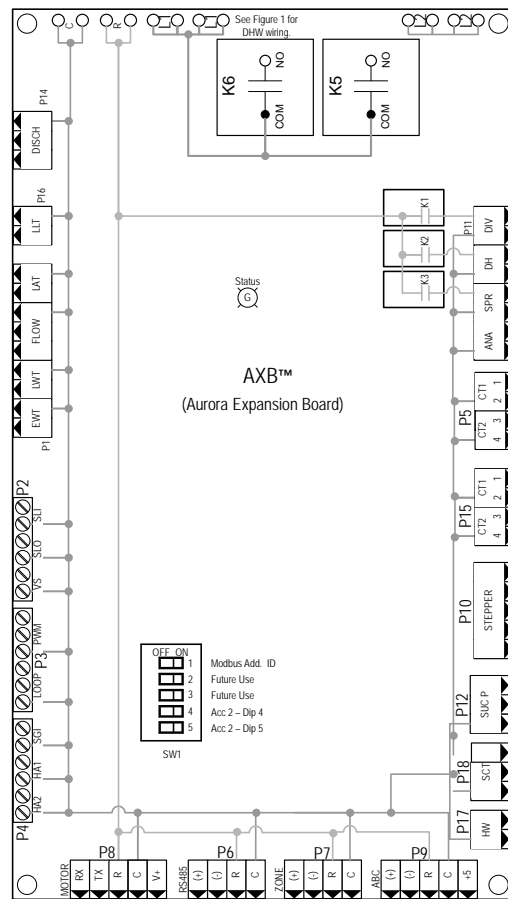

EEV Board Layout

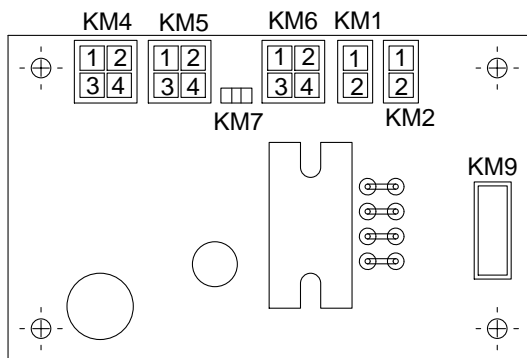

Variable Speed Drive

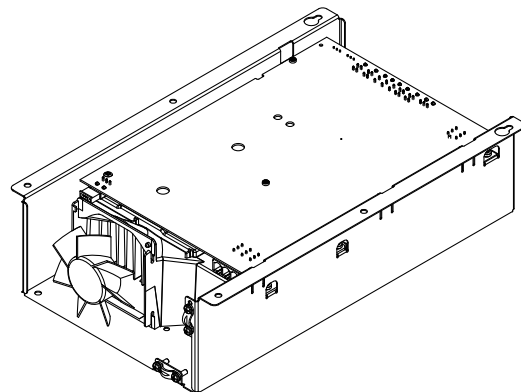

Operation Logic

Heating Mode

When the variable speed controls determine that heating is needed in the space the blower will be turned on, the compressor will be ramped to speed 6 and the loop pump will be started. The compressor will continue to run at speed 6 for 60 seconds for oil circulation. During the 60 second oil circulation the controls will calculate what speed the compressor will need to operate at to maintain the set point in the space. If the compressor is operating at speed 12 and the unit is unable to maintain set point the controls will stage on the electric heat. Electric heat will not operate unless the compressor is already running at speed 12. Every 30 minutes if the compressor has been operating lower than speed 6, the controls will increase the compressor to speed 6 for one minute for oil circulation.

Cooling Mode

When the variable speed controls determine that cooling is needed in the space the blower will be turned on, the reversing valve will be enabled, the compressor will be ramped to speed 6, and the loop pump will be started. The compressor will continue to run at speed 6 for 60 seconds for oil circulation. During the 60 second oil circulation the controls will calculate what speed the compressor will need to operate at to maintain the set point in the space. The compressor will be limited to a maximum of speed 9 for cooling. If additional capacity is needed SuperBoost mode can be enabled from the thermostat allowing the compressor to run at speeds higher than 9 for a period of 24 hours. Every 30 minutes if the compressor has been operating lower than speed 6, the controls will increase the compressor to speed 6 for one minute for oil circulation.

Variable Speed ECM Blower Motor

The variable speed controls will vary the variable speed ECM blower output to maintain optimum air flow at each of the 12 compressor speeds. If dehumidification mode is selected during the cooling operation the airflow will be varied to allow for maximum moisture removal.

Variable Speed Loop Pump

The variable speed controls will operate the variable speed loop pump similar to the way the variable speed ECM blower motor operates. The speed of the pump will be increased as the compressor speed is increased to maintain adequate water flow.

Safe Mode

The system has encountered an unsafe operating condition that prevents automatic speed control, e.g. lost a sensor signal. To avoid damage to the system, the drive is running the compressor at a fixed speed of 2400 rpm awaiting the problem to be solved and eventually returning to normal operation. If the problem cannot be solved the drive stops and issues an alarm. (See fault/ alarm table.)

Derating

The VS compressor utilizes 'envelope control' to maintain performance within operational limits and improve reliability. To accomplish this, pressure sensors for discharge and suction pressure as well as hot gas temperature sensing are used to monitor the conditions in which the compressor operates. The envelope does vary based upon operating speed (rpm). When operating out of these limits the control will attempt to improve the situation by moderating the compressor speed for a larger envelope. When this occurs it can be observed on the Aurora control as an 'E' code. The control will automatically try to resolve the situation. If the situation progresses, a fault and lockout will be generated by the control.

Water Quality

In ground water situations where scaling could be heavy or where biological growth such as iron bacteria will be present, a closed loop system is recommended. The heat exchanger coils in ground water systems may, over a period of time, lose heat exchange capabilities due to a buildup of mineral deposits inside. These can be cleaned, but only by a qualified service mechanic, as special solutions and pumping equipment are required. Hot water generator coils can likewise become scaled and possibly plugged.

In areas with extremely hard water, the owner should be informed that the heat exchanger may require occasional flushing.

Units with cupronickel heat exchangers are recommended for open loop applications due to the increased resistance to build-up and corrosion, along with reduced wear caused by acid cleaning. Failure to adhere to the guidelines in the water quality table could result in the loss of warranty.

Material		Copper	90/10 Cupronickel	316 Stainless Steel
pH	Acidity/Alkalinity	7 - 9	7 - 9	7 - 9
Scaling	Calcium and Magnesium Carbonate	(Total Hardness) less than 350 ppm	(Total Hardness) less than 350 ppm	(Total Hardness) less than 350 ppm
Corrosion	Hydrogen Sulfide	Less than 0.5 ppm (rotten egg smell appears at 0.5 ppm)	10 - 50 ppm	Less than 1 ppm
	Sulfates	Less than 125 ppm	Less than 125 ppm	Less than 200 ppm
	Chlorine	Less than 0.5 ppm	Less than 0.5 ppm	Less than 0.5 ppm
	Chlorides	Less than 20 ppm	Less than 125 ppm	Less than 300 ppm
	Carbon Dioxide	Less than 50 ppm	10 - 50 ppm	10 - 50 ppm
	Ammonia	Less than 2 ppm	Less than 2 ppm	Less than 20 ppm
	Ammonia Chloride	Less than 0.5 ppm	Less than 0.5 ppm	Less than 0.5 ppm
	Ammonia Nitrate	Less than 0.5 ppm	Less than 0.5 ppm	Less than 0.5 ppm
	Ammonia Hydroxide	Less than 0.5 ppm	Less than 0.5 ppm	Less than 0.5 ppm
	Ammonia Sulfate	Less than 0.5 ppm	Less than 0.5 ppm	Less than 0.5 ppm
	Total Dissolved Solids (TDS)	Less than 1000 ppm	1000 - 1500 ppm	1000 - 1500 ppm
LSI Index	+0.5 to -0.5	+0.5 to -0.5	+0.5 to -0.5	
Iron Fouling (Biological Growth)	Iron, FE ²⁺ (Ferrous) Bacterial Iron Potential	< 0.2 ppm	< 0.2 ppm	< 0.2 ppm
	Iron Oxide	Less than 1 ppm, above this level deposition will occur	Less than 1 ppm, above this level deposition will occur	Less than 1 ppm, above this level deposition will occur
Erosion	Suspended Solids	Less than 10 ppm and filtered for max. of 600 micron size	Less than 10 ppm and filtered for max. of 600 micron size	Less than 10 ppm and filtered for max. of 600 micron size
	Threshold Velocity (Fresh Water)	< 6 ft/sec	< 6 ft/sec	< 6 ft/sec

NOTES: Grains = ppm divided by 17
mg/L is equivalent to ppm

2/22/12

Vertical Dimensional Data

Top Air Discharge

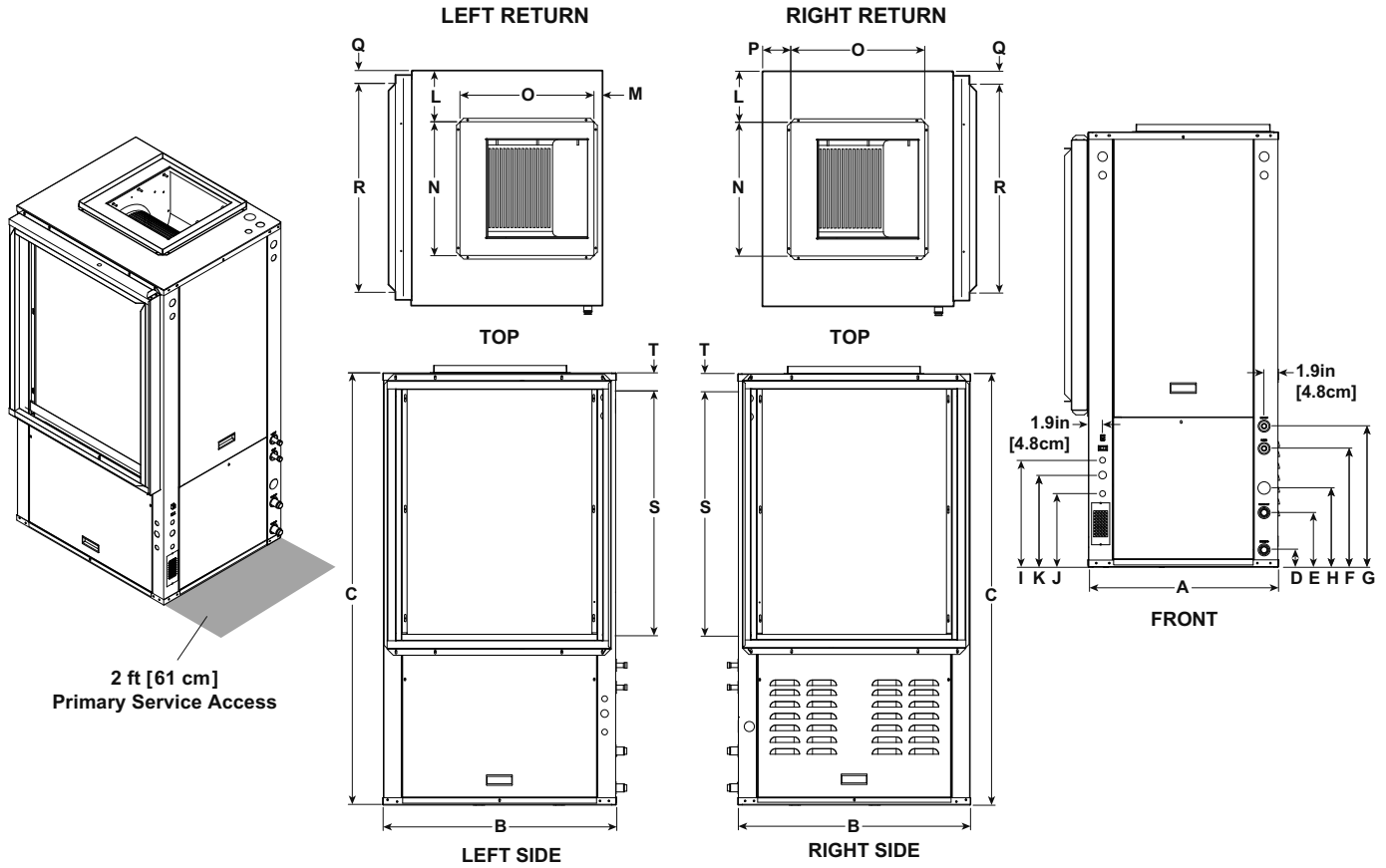

Vertical Top Flow Model	Overall Cabinet			Water Connections								Electrical Connections			Discharge Connection duct flange installed (±0.10 in)					Return Connection using std deluxe filter rack (±0.10 in)			
	A	B	C	D	E	F	G	H	Loop	HWG	I	J	K	L	M	N	O	P	Q	R	S	T	
	Width	Depth	Height	Loop In	Loop Out	HWG In	HWG Out	Condensate	Water FPT	Sweat (I.D.)	1/2 in. cond Low Voltage	1/2 in. cond Ext Pump	3/4 in. cond Power Supply			Supply Width	Supply Depth		Return Depth	Return Height			
036	in.	25.6	31.6	54.4	2.3	7.3	15.9	18.9	10.6	1 in. Swivel	1/2 in. Female	14.3	9.8	12.3	6.9	1.1	18.0	18.0	3.8	1.7	28.1	30.0	1.7
	cm.	65.0	80.3	138.2	5.8	18.5	40.4	48.0	26.9			36.3	24.9	31.2	17.5	2.8	45.7	45.7	9.7	4.3	71.4	76.2	4.3
048	in.	25.6	31.6	54.4	2.3	7.3	15.9	18.9	10.6	1 in. Swivel	1/2 in. Female	14.3	9.8	12.3	6.9	1.1	18.0	18.0	3.8	1.7	28.1	30.0	1.7
	cm.	65.0	80.3	138.2	5.8	18.5	40.4	48.0	26.9			36.3	24.9	31.2	17.5	2.8	45.7	45.7	9.7	4.3	71.4	76.2	4.3
060	in.	25.6	31.6	58.4	2.3	7.3	15.9	18.9	10.6	1 in. Swivel	1/2 in. Female	14.3	9.8	12.3	6.9	1.1	18.0	18.0	3.8	1.7	28.1	34.0	1.7
	cm.	65.0	80.3	148.3	5.8	18.5	40.4	48.0	26.9			36.3	24.9	31.2	17.5	2.8	45.7	45.7	9.7	4.3	71.4	86.4	4.3

Condensate is 3/4 in. PVC female glue socket and is switchable from side to front
 Unit shipped with deluxe 2 in. (field adjustable to 1 in.) duct collar/filter rack extending from unit 3.25 in. and is suitable for duct connection.
 Discharge flange is field installed and extends 1 in. [25.4mm] from cabinet
 Decorative molding and/or water connections extend 1.2 in. [30.5mm] beyond front of cabinet.
 Louvered vents in the compressor section right side access panel extend 1/2 in. [12.7 mm] from side of cabinet. Allow clearance for venting.
 Top auxiliary electric heat power knockouts are 1.125", 1.375", and 2".

6/29/12

Vertical Dimensional Data cont.

Bottom Air Discharge

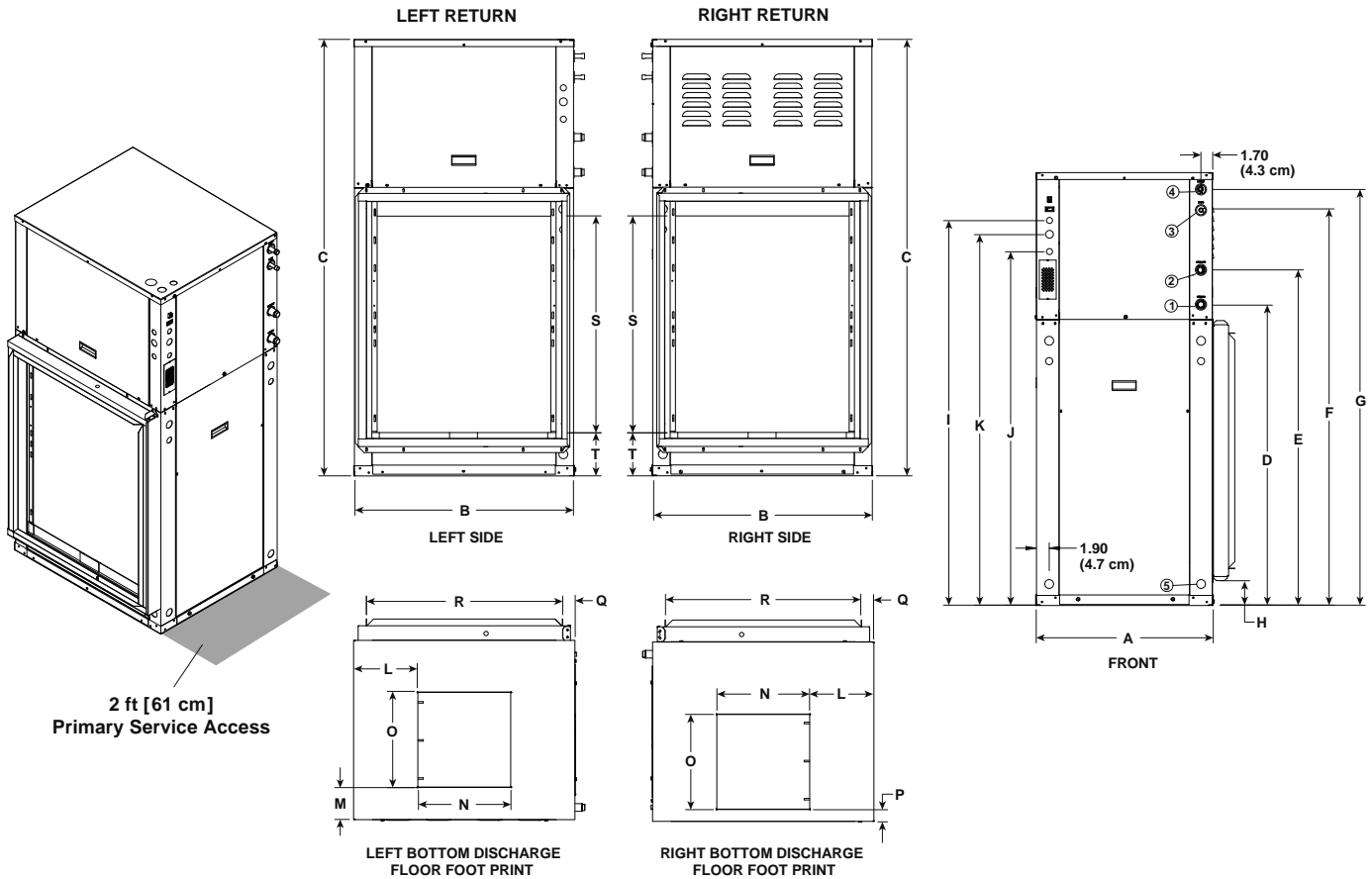

Bottomflow Models	Overall Cabinet			Water Connections					Electrical Knockouts			Discharge Connection duct flange installed (±0.10 in)				Return Connection using std deluxe filter rack (±0.10 in)						
	A Width	B Depth	C Height	D In	E Out	F HWG In	G HWG Out	H Cond- ensate	Loop Water FPT	HWG Sweat (I.D.)	I 1/2 in. cond	J 1/2 in. cond	K 3/4 in. cond	L	M	N Supply Width	O Supply Depth	P	Q	R Return Depth	S Return Height	T
036-060	in.	25.5	31.5	62.5	43.4	48.4	57.0	60.0	3.1	1 in.	51.1	55.6	53.6	9.1	4.8	13.4	13.6	1.7	1.8	28.1	34.0	5.6
	cm.	64.8	80.0	158.8	110.2	122.9	144.8	152.4	7.9	Swivel	129.8	141.2	136.1	23.1	12.2	34.0	34.5	4.3	4.6	71.4	86.4	14.2

Condensate is 3/4 in. PVC female glue socket and is switchable from side to front
 Unit shipped with deluxe 2 in. (field adjustable to 1 in.) duct collar/filter rack extending from unit 3.25 in. and is suitable for duct connection.
 Decorative molding and/or water connections extend 1.2 in. [30.5mm] beyond front of cabinet.
 Louvered vents in the compressor section right side access panel extend 1/2 in. [12.7 mm] from side of cabinet. Allow clearance for venting.
 Top auxiliary electric heat power knockouts are 1.125", 1.375", and 2".

4/30/12

Vertical Dimensional Data cont.

Rear Air Discharge

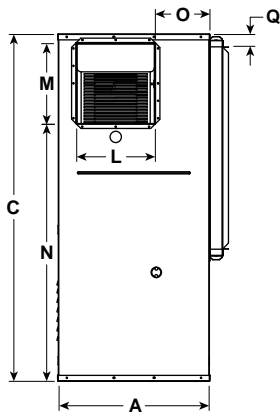
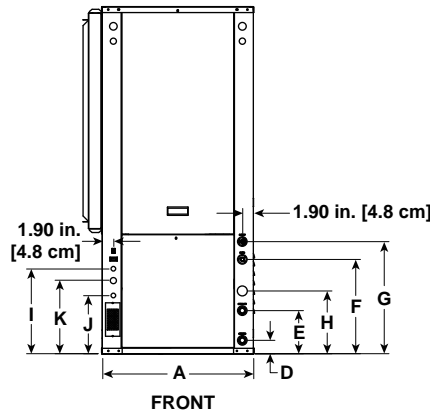
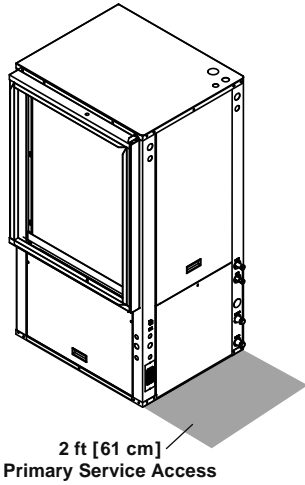

REAR VIEW
LEFT RETURN

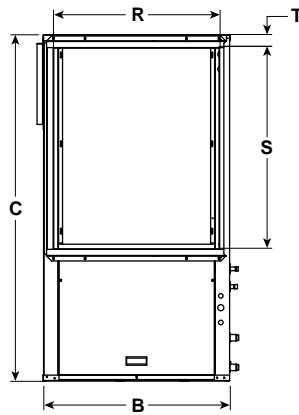

SIDE VIEW
LEFT RETURN

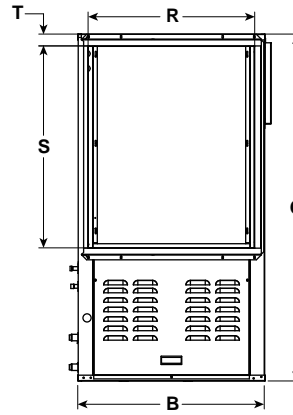

SIDE VIEW
RIGHT RETURN

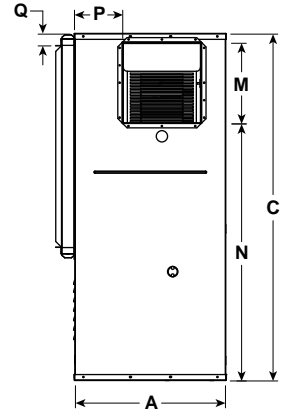

REAR VIEW
RIGHT RETURN

Vertical Rear Discharge Model	Overall Cabinet			Water Connections							Electrical Connections			Discharge Connection duct flange installed (±0.10 in)					Return Connection using std deluxe filter rack (±0.10 in)				
	A Width	B Depth	C Height	D Loop In	E Loop Out	F HWG In	G HWG Out	H Condensate	Loop Water FPT	HWG Sweat (I.D.)	I 1/2 in. cond Low Voltage	J 1/2 in. cond Ext Pump	K 3/4 in. cond Power Supply	L Supply Width	M Supply Depth	N	O	P	Q	R Return Depth	S Return Height	T	
036	in.	25.6	31.6	54.4	2.3	7.3	15.9	18.9	10.6	1 in. Swivel	1/2 in. Female	14.3	9.8	12.3	13.3	13.6	39.4	9.1	8.1	1.7	28.1	30.0	1.7
	cm.	65.0	80.3	138.2	5.8	18.5	40.4	48.0	26.9			36.3	24.9	31.2	33.8	34.5	100.1	23.1	20.6	4.3	71.4	76.2	4.3
048	in.	25.6	31.6	54.4	2.3	7.3	15.9	18.9	10.6	1 in. Swivel	1/2 in. Female	14.3	9.8	12.3	13.3	13.6	39.4	9.1	8.1	1.7	28.1	30.0	1.7
	cm.	65.0	80.3	138.2	5.8	18.5	40.4	48.0	26.9			36.3	24.9	31.2	33.8	34.5	100.1	23.1	20.6	4.3	71.4	76.2	4.3
060	in.	25.6	31.6	58.4	2.3	7.3	15.9	18.9	10.6	1 in. Swivel	1/2 in. Female	14.3	9.8	12.3	13.3	13.6	43.4	9.1	8.1	1.7	28.1	34.0	1.7
	cm.	65.0	80.3	148.3	5.8	18.5	40.4	48.0	26.9			36.3	24.9	31.2	33.8	34.5	110.2	23.1	20.6	4.3	71.4	86.4	4.3

Condensate is 3/4 in. PVC female glue socket and is switchable from side to front
 Unit shipped with deluxe 2 in. (field adjustable to 1 in.) duct collar/filter rack extending from unit 3.25 in. and is suitable for duct connection.
 Discharge flange is field installed and extends 1 in. [25.4mm] from cabinet
 Decorative molding and/or water connections extend 1.2 in. [30.5mm] beyond front of cabinet.
 Louvered vents in the compressor section right side access panel extend 1/2 in. [12.7 mm] from side of cabinet. Allow clearance for venting.
 Top auxiliary electric heat power knockouts are 1.125", 1.375", and 2".

6/29/12

Horizontal Dimensional Data

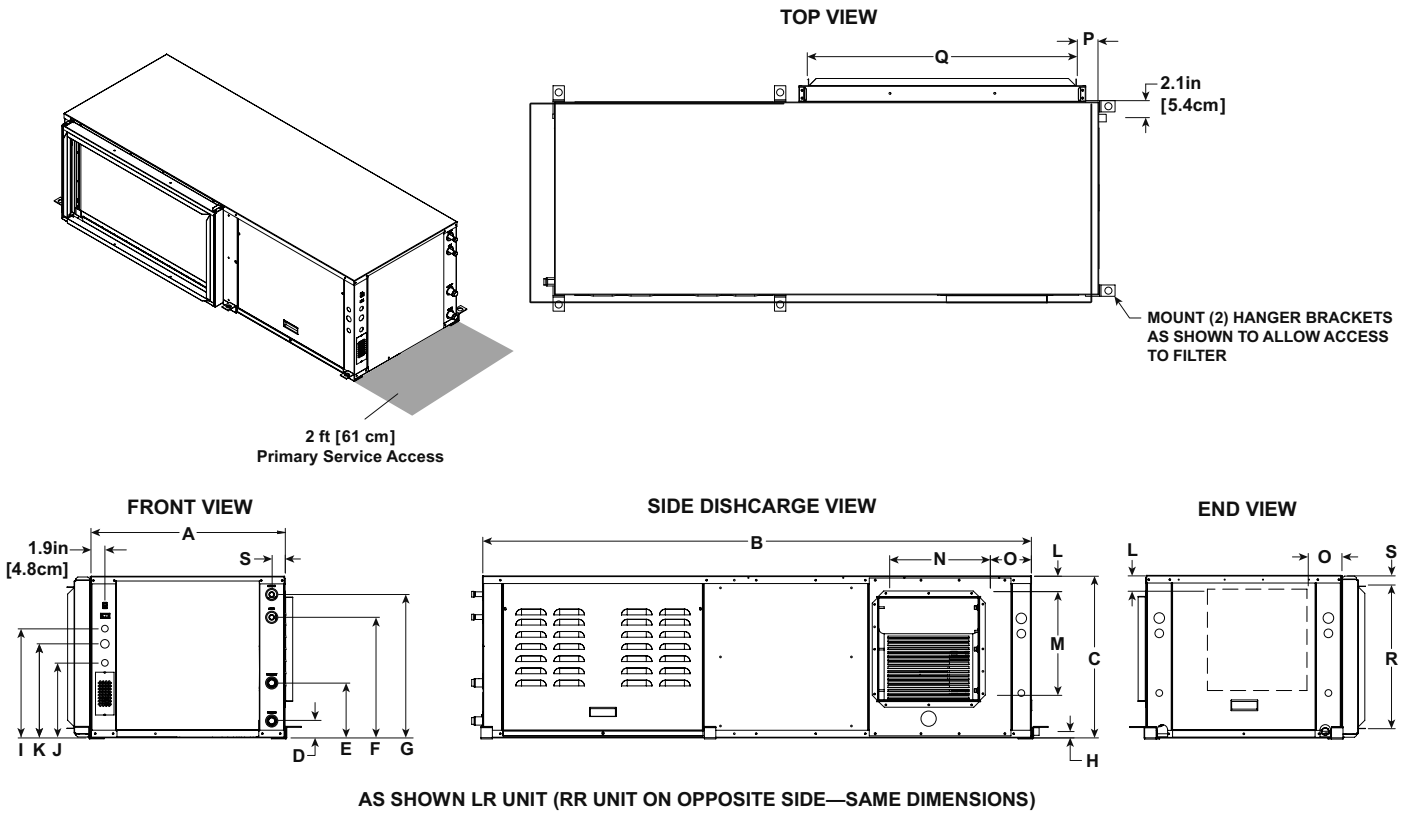

Horizontal Models	Overall Cabinet			Water Connections								Electrical Connections			Discharge Connection duct flange installed (±0.10 in)				Return Connection using std deluxe filter rack (±0.10 in)			
	A	B	C	D	E	F	G	H	Loop Water FPT	HWG Sweat (L.D.)	I	J	K	L	M	N	O	P	Q	R	S	
	Width	Depth	Height	In	Out	HWG In	HWG Out	Condensate			1/2 in. cond	1/2 in. cond	3/4 in. cond		Supply Height	Supply Depth		Return Depth	Return Height			
036	in.	25.6	77.0	21.3	2.3	7.3	15.9	18.9	0.8	1 in.	1/2 in.	14.3	9.8	12.3	SEE	13.6	13.2	SEE	2.8	40.4	18.9	1.3
	cm.	65.0	195.6	54.1	5.8	18.5	40.4	48.0	2.0	Swivel	Female	36.3	24.9	31.2	CHART	34.5	33.5	CHART	7.1	102.6	48.0	3.3
048	in.	25.6	77.0	21.3	2.3	7.3	15.9	18.9	0.8	1 in.	1/2 in.	14.3	9.8	12.3	SEE	13.6	13.2	SEE	2.8	40.4	18.9	1.3
	cm.	65.0	195.6	54.1	5.8	18.5	40.4	48.0	2.0	Swivel	Female	36.3	24.9	31.2	CHART	34.5	33.5	CHART	7.1	102.6	48.0	3.3
060	in.	25.6	82.0	21.3	2.3	7.3	15.9	18.9	0.8	1 in.	1/2 in.	14.3	9.8	12.3	SEE	13.6	13.2	SEE	2.8	45.4	18.9	1.3
	cm.	65.0	208.3	54.1	5.8	18.5	40.4	48.0	2.0	Swivel	Female	36.3	24.9	31.2	CHART	34.5	33.5	CHART	7.1	115.3	48.0	3.3

Condensate is 3/4 in. PVC female glue socket and is switchable from side to front
 Unit shipped with deluxe 2 in. (field adjustable to 1 in.) duct collar/filter rack extending from unit 3.25 in. and is suitable for duct connection.
 Discharge flange is field installed and extends 1 in. [25.4mm] from cabinet
 Decorative molding and/or water connections extend 1.2 in. [30.5mm] beyond front of cabinet.
 Louvered vents in the compressor section right side access panel extend 1/2 in. [12.7 mm] from side of cabinet. Allow clearance for venting.

6/29/12

Units Not Shown Above		L	O
Right Return End Discharge	in	2.8	4.6
	cm	7.1	11.8
Right Return Side Discharge	in	4.9	6.9
	cm	12.4	17.5
Left Return End Discharge	in	4.9	7.6
	cm	12.4	19.4
Left Return Side Discharge	in	2.8	6.9
	cm	7.1	17.5

Physical Data

Model		Variable Speed		
		036	048	060
Compressor (1 each)		Variable Speed Scroll		
Factory Charge R-410A, oz [kg] Vertical		95 [2.69]	120 [3.40]	140 [3.96]
Factory Charge R-410A, oz [kg] Horizontal		95 [2.69]	136 [3.85]	148 [4.19]
ECM Blower Motor & Blower				
Blower Motor Type/Speeds	ECM	Variable Speed		
Blower Motor- hp [W]	ECM	1/2 [373]	1 [746]	1 [746]
High Static Blower Motor - hp [W]	ECM	1 [746]	n/a	n/a
Blower Wheel Size (Dia x W), in. [mm]	ECM	11 x 10 [279 x 254]	11 x 10 [279 x 254]	11 x 10 [279 x 254]
High Static Blower Wheel Size - [Dia. x W], in. [mm]	ECM	11 x 10 [279 x 254]	n/a	n/a
Coax and Water Piping				
Water Connections Size - Swivel - in [mm]		1 [25.4]	1 [25.4]	1 [25.4]
HWG Connection Size - Female Sweat I.D. - in [mm]		1/2 [12.7]	1/2 [12.7]	1/2 [12.7]
Coax & Piping Water Volume - gal [l]		1.6 [6.1]	1.6 [6.1]	2.3 [8.7]
Vertical				
Air Coil Dimensions (H x W), in. [mm]		32 x 25 [813 x 635]	32 x 25 [813 x 635]	36 x 25 [914 x 635]
Air Coil Total Face Area, ft ² [m ²]		5.6 [0.570]	5.6 [0.570]	6.3 [0.641]
Air Coil Tube Size, in [mm]		3/8 [9.5]	3/8 [9.5]	3/8 [9.5]
Air Coil Number of rows		3	3	4
Filter Standard - 2 in. [51 mm] Pleated MERV 11 Throwaway, in [mm]		32 x 30 [813 x 762]	32 x 30 [813 x 762]	36 x 30 [914 x 762]
Weight - Operating, lb [kg]		352 [160]	361 [164]	385 [175]
Weight - Packaged, lb [kg]		372 [169]	381 [173]	405 [184]
Horizontal				
Air Coil Dimensions (H x W), in. [mm]		20 x 40 [508 x 1016]	20 x 40 [508 x 1016]	20 x 45 [508 x 1143]
Air Coil Total Face Area, ft ² [m ²]		5.6 [0.570]	5.6 [0.570]	6.3 [0.641]
Air Coil Tube Size, in [mm]		3/8 [9.5]	3/8 [9.5]	3/8 [9.5]
Air Coil Number of rows		3	3	4
Filter Standard - 2 in. [51 mm] Pleated MERV 11 Throwaway, in [mm]		1 - 20 x 20 [508 x 508] 1 - 20 x 22 [508 x 559]	1 - 20 x 20 [508 x 508] 1 - 20 x 22 [508 x 559]	1 - 20 x 25 [508 x 635] 1 - 20 x 22 [508 x 559]
Weight - Operating, lb [kg]		387 [176]	396 [180]	415 [188]
Weight - Packaged, lb [kg]		417 [189]	426 [193]	445 [202]

Auxiliary Heat Ratings

Model	kW		Stages	Btu/h		Min CFM	Model Compatibility		
	208V	230V		208V	230V		036	048	060
EAL(H)10A	7.2	9.6	2	24,600	32,700	1100	•	•	•
EAL(H)15A	10.8	14.4	3	36,900	49,100	1250	•	•	•
EAL(H)20A	14.4	19.2	4	49,200	65,500	1500		•	•

Air flow level for auxiliary heat (Aux) must be above the minimum cfm in this table
Order the "H" part number when installed on horizontal and vertical rear discharge units

6/1/12

Auxiliary Heat Electrical Data

Model	Supply Circuit	Heater Amps		Min Circuit Amp		Max Fuse (USA)		Max Fuse (CAN)		Max CKT BRK	
		208 V	240 V	208 V	240 V	208 V	240 V	208 V	240 V	208 V	240 V
EAL(H)10A	Single	34.7	40	53.3	60	60	60	60	60	60	60
EAL(H)15A	Single	52.0	60	75	85	80	90	80	90	70	100
	L1/L2	34.7	40	53.3	60	60	60	60	60	60	60
	L3/L4	17.3	20	21.7	25	25	25	25	25	20	30
EAL(H)20A	Single	69.3	80	96.7	110	100	110	100	110	100	100
	L1/L2	34.7	40	53.3	60	60	60	60	60	60	60
	L3/L4	34.7	40	43.3	50	45	50	45	50	40	50

All heaters rated single phase 60 cycle and include unit fan load
All fuses type "D" time delay (or HACR circuit breaker in USA)

6/1/12

Electrical Data

Model	Rated Voltage	Voltage Min/Max	Compressor		Drive		HWG Pump FLA	Ext Loop FLA	Blower Motor FLA	Total Unit FLA	Minimum Circuit Amp	Max Fuse HACR Breaker
			LRA	CMCC	LRA	Internal Breaker						
036	208-230/60/1	187/253	10.2	18.0	22.0	30.0	0.4	5.4	4.0	31.8	37.3	40
*036	208-230/60/1	187/253	10.2	18.0	22.0	30.0	0.4	5.4	7.0	34.8	40.3	45
048	208-230/60/1	187/253	12.0	23.5	28.0	35.0	0.4	5.4	7.0	40.8	47.8	50
060	208-230/60/1	187/253	12.0	30.0	33.0	40.0	0.4	5.4	7.0	45.8	54.1	60

*With optional 1 hp Variable Speed ECM Motor
Rated Voltage of 208/230/60/1
HACR circuit breaker in USA only
All fuses Class RK-5

3/26/12

Blower Performance Data

Variable Speed ECM Blower Motor

Model	Air Flow												
	Max ESP	Speed 1	Speed 2	Speed 3	Speed 4	Speed 5	Speed 6	Speed 7	Speed 8	Speed 9	Speed 10	Speed 11	Speed 12
036	0.50	285	380 G	525 L	675	815	980	1100	1220	1330	1440 H	1540 Aux	1575
036 w/1hp*	0.75	480	565 G	665 L	761	870	1000	1100	1200	1300	1410 H	1520 Aux	1630
048	0.75	475	620 G	730 L	850	1020	1140	1270	1400	1520	1650 H	1790 Aux	1925
060	0.75	400	600 G	830 L	1050	1230	1400	1560	1700	1870	2010 H	2140 Aux	2265
**VS Compressor Speed				1-2	3-4		5-6	7-8		9-10	11-12		

** VS Compressor speed is given for the factory default cfm settings. When the cfm default settings are changed it will change the relationship to the compressor speed that is shown in the table. In cooling mode compressor speeds 10-12 are only available when SuperBoost mode is selected at the thermostat. 6/7/12

* Optional 1 hp Variable Speed ECM

Factory settings are at recommended L, H and Aux positions

"G" may be located anywhere within the airflow table

"L" setting should be located within the boldface cfm range

"H" setting MUST be located within the shaded cfm range

"Aux" setting MUST be equal to or greater than "H" setting

"Aux" setting MUST be equal to or greater than the minimum allowable cfm for the auxiliary heater kit (see auxiliary heat ratings table)

Cfm is controlled within 5% up to the maximum ESP

Max ESP includes allowance for wet coil and standard filter

Setting Blower Speed - Variable Speed ECM

The ABC board's Yellow Config LED will flash the current ECM blower speed selections for G, low, and high continuously with a short pause in between. The speeds can also be confirmed with the AID Tool under the Setup/ECM Setup screen. The Aux will not be flashed but can be viewed in the AID Tool. The ECM blower motor speeds can be field adjusted with or without using an AID Tool.

Variable Speed ECM Setup without an AID Tool

The blower speeds for G only, Low (Y1), and High (Y2/Aux) can be adjusted directly at the Aurora ABC board which utilizes the push button (SW1) on the ABC board. This procedure is outlined in the ECM Configuration Mode portion of the Aurora 'Base' Control System section. The Aux cannot be set manually without an AID Tool.

Variable Speed ECM Setup with an AID Tool

A much easier method utilizes the AID Tool to change the airflow using the procedure below. First navigate to the Setup screen and then select ECM Setup. This screen displays the current ECM settings. It allows the technician to enter the setup screens to change the ECM settings. Change the highlighted item using the ◀ and ▶ buttons and then press the ■ button to select the item.

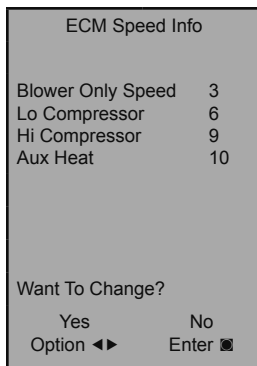

Selecting YES will enter ECM speed setup, while selecting NO will return to the previous screen.

ECM Speed Setup - These screens allow the technician to select the G, low, high, and auxiliary heat blower speed for the ECM blower motor. Change the highlighted item using the ▲ and ▼ buttons. Press the ■ button to select the speed.

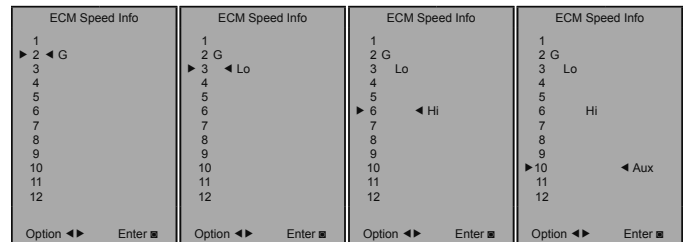

After the auxiliary heat speed setting is selected the AID Tool will automatically transfer back to the ECM Setup screen.

Cooling Airflow Setup - These screens allow the technician to select -15%, -10%, -5%, None or +5% change from the heating airflow. Change the adjustment percentage using the ▲ and ▼ buttons. Press the ■ button to save the change.

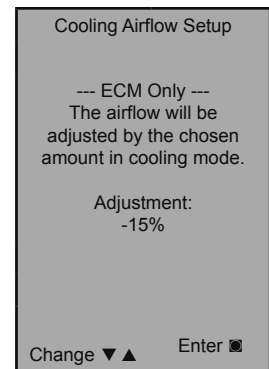
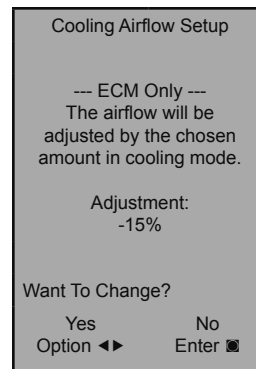

Reference Calculations

Heating Calculations:	Cooling Calculations:
$LWT = EWT - \frac{HE}{gpm \times 500}$	$LWT = EWT + \frac{HR}{gpm \times 500}$
$LAT = EAT + \frac{HC}{cfm \times 1.08}$	$LAT (DB) = EAT (DB) - \frac{SC}{cfm \times 1.08}$
$TH = HC + HW$	$LC = TC - SC$
	$S/T = \frac{SC}{TC}$

Legend and Notes

Abbreviations and Definitions

cfm	= airflow, cubic feet/minute	HWC	= hot water generator capacity, MBtu/h
EWT	= entering water temperature, Fahrenheit	EER	= Energy Efficient Ratio
gpm	= water flow in gallons/minute		= Btu output/Watt input
WPD	= water pressure drop, psi and feet of water	COP	= Coefficient of Performance
EAT	= entering air temperature, Fahrenheit (dry bulb/wet bulb)		= Btu output/Btu input
HC	= air heating capacity, MBtu/h	LWT	= leaving water temperature, °F
TC	= total cooling capacity, MBtu/h	LAT	= leaving air temperature, °F
SC	= sensible cooling capacity, MBtu/h	TH	= total heating capacity, MBtu/h
KW	= total power unit input, kilowatts	LC	= latent cooling capacity, MBtu/h
HR	= total heat of rejection, MBtu/h	S/T	= sensible to total cooling ratio
HE	= total heat of extraction, MBtu/h		

Notes to Performance Data Tables

The following notes apply to all performance data tables:

- Performance ratings are based on 80°F DB/67°F WB EAT for cooling and 70°F DB EAT for heating.
- Three flow rates are shown for each unit. The lowest flow rate shown is used for geothermal open loop/well water systems with a minimum of 50°F EWT. The middle flow rate shown is the minimum geothermal closed loop flow rate. The highest flow rate shown is optimum for geothermal closed loop systems and the suggested flow rate for boiler/tower applications.
- The hot water generator numbers are based on a flow rate of 0.4 gpm/ton of rated capacity with an EWT of 90°F.
- Entering water temperatures below 40°F assumes 15% antifreeze solution.
- For non-standard EAT conditions, apply the appropriate Correction Factor tables.
- Interpolation between EWT, gpm, and cfm data is permissible, extrapolation is not.

Operating Limits

Operating Limits	Cooling		Heating	
	(°F)	(°C)	(°F)	(°C)
Air Limits				
Min. Ambient Air	45	7.2	45	7.2
Rated Ambient Air	80	26.7	70	21.1
Max. Ambient Air	100	37.8	85	29.4
Min. Entering Air	50	10.0	40	4.4
Rated Entering Air db/wb	80.6/66.2	27/19	68	20.0
Max. Entering Air db/wb	110/83	43/28.3	80	26.7
Water Limits				
Min. Entering Water	30	-1.1	20	-6.7
Normal Entering Water	50-110	10-43.3	30-70	-1.1
Max. Entering Water	120	48.9	90	32.2

NOTE: Minimum/maximum limits are only for start-up conditions, and are meant for bringing the space up to occupancy temperature. Units are not designed to operate at the minimum/maximum conditions on a regular basis. The operating limits are dependent upon three primary factors: 1) water temperature, 2) return air temperature, and 3) ambient temperature. When any of the factors are at the minimum or maximum levels, the other two factors must be at the normal level for proper and reliable unit operation.

Antifreeze Corrections

Catalog performance can be corrected for antifreeze use. Please use the following table and note the example given.

Antifreeze Type	Antifreeze % by wt	Heating	Cooling	Pressure Drop
EWT - °F [°C]		30 [-1.1]	90 [32.2]	30 [-1.1]
Water	0	1.000	1.000	1.000
Ethylene Glycol	10	0.973	0.991	1.075
	20	0.943	0.979	1.163
	30	0.917	0.965	1.225
	40	0.890	0.955	1.324
	50	0.865	0.943	1.419
Propylene Glycol	10	0.958	0.981	1.130
	20	0.913	0.969	1.270
	30	0.854	0.950	1.433
	40	0.813	0.937	1.614
	50	0.770	0.922	1.816
Ethanol	10	0.927	0.991	1.242
	20	0.887	0.972	1.343
	30	0.856	0.947	1.383
	40	0.815	0.930	1.523
	50	0.779	0.911	1.639
Methanol	10	0.957	0.986	1.127
	20	0.924	0.970	1.197
	30	0.895	0.951	1.235
	40	0.863	0.936	1.323
	50	0.833	0.920	1.399



WARNING: Gray area represents antifreeze concentrations greater than 35% by weight and should be avoided due to the extreme performance penalty they represent.

Antifreeze Correction Example

Antifreeze solution is Propylene Glycol 20% by weight. Determine the corrected heating and cooling performance at 30°F and 90°F respectively as well as pressure drop at 30°F for Model 036 operating at 100% capacity.

The corrected cooling capacity at 90°F would be: 35,200 MBtu/h x 0.969 = 34,109 MBtu/h

The corrected heating capacity at 30°F would be: 37,400 MBtu/h x 0.913 = 34,146 MBtu/h

The corrected pressure drop at 30°F and 11.5 gpm would be: 7.9 feet of head x 1.270 = 10.03 feet of head

Pressure Drop

Model	gpm	Pressure Drop (psi)				
		30° F	50° F	70°	90° F	110° F
36	11.5	3.40	3.20	3.00	2.80	2.60
	9.0	2.70	2.60	2.40	2.20	2.10
	7.0	1.65	1.55	1.45	1.35	1.25
	5.5	1.10	1.00	0.90	0.85	0.75
	4.5	0.68	0.64	0.60	0.55	0.51
48	13.5	4.60	4.40	4.10	3.80	3.50
	10.5	2.90	2.70	2.50	2.30	2.20
	7.5	1.70	1.60	1.50	1.40	1.30
	6.0	1.20	1.10	1.00	0.96	0.91
	4.0	0.62	0.61	0.60	0.58	0.56
60	17.0	6.40	6.00	5.60	5.20	4.80
	13.5	4.10	3.80	3.60	3.30	3.10
	9.5	2.20	2.10	2.00	1.80	1.70
	7.5	1.70	1.60	1.50	1.40	1.30
	5.0	0.68	0.62	0.58	0.55	0.53

6/29/12

Correction Factor Tables

Air Flow Corrections (Compressor Speeds 1-3)

Airflow		Cooling				Heating		
CFM Per Ton of Clg	% of Nominal	Total Cap	Sens Cap	Power	Heat of Rej	Htg Cap	Power	Heat of Ext
240	60	0.940	0.740	0.967	0.951	0.943	1.106	0.902
275	69	0.950	0.783	0.973	0.959	0.953	1.088	0.918
300	75	0.960	0.827	0.978	0.967	0.962	1.070	0.935
325	81	0.970	0.870	0.984	0.975	0.972	1.053	0.951
350	88	0.980	0.913	0.989	0.984	0.981	1.035	0.967
375	94	0.990	0.957	0.995	0.992	0.991	1.018	0.984
400	100	1.000	1.000	1.000	1.000	1.000	1.000	1.000
425	106	1.030	1.022	1.024	1.026	1.009	0.982	1.016
450	113	1.060	1.045	1.048	1.051	1.019	0.965	1.033
475	119	1.091	1.067	1.071	1.077	1.028	0.947	1.049
500	125	1.121	1.089	1.095	1.103	1.038	0.930	1.065
520	130	1.151	1.111	1.110	1.129	1.047	0.912	1.082

6/29/12

Air Flow Corrections (Compressor Speeds 4-12)

Airflow		Cooling				Heating		
CFM Per Ton of Clg	% of Nominal	Total Cap	Sens Cap	Power	Heat of Rej	Htg Cap	Power	Heat of Ext
240	60	0.928	0.747	0.936	0.929	0.961	1.097	0.938
275	69	0.940	0.789	0.946	0.941	0.967	1.081	0.948
300	75	0.952	0.831	0.957	0.953	0.974	1.064	0.959
325	81	0.964	0.873	0.968	0.965	0.980	1.048	0.969
350	88	0.976	0.916	0.979	0.976	0.987	1.032	0.979
375	94	0.988	0.958	0.989	0.988	0.993	1.016	0.990
400	100	1.000	1.000	1.000	1.000	1.000	1.000	1.000
425	106	1.020	1.023	1.004	1.018	1.010	0.966	1.018
450	113	1.056	1.042	1.008	1.035	1.020	0.932	1.036
475	119	1.072	1.079	1.011	1.053	1.029	0.898	1.054
500	125	1.087	1.095	1.015	1.070	1.039	0.865	1.071
520	130	1.099	1.113	1.019	1.088	1.049	0.831	1.089

6/14/12

Cooling Capacity Corrections

Entering Air WB °F	Total Clg Cap	Sensible Cooling Capacity Multipliers - Entering DB °F										Power Input	Heat of Rejection
		60	65	70	75	80	80.6	85	90	95	100		
55	0.898	0.723	0.866	1.048	1.185	*	*	*	*	*	*	0.985	0.913
60	0.912		0.632	0.880	1.078	1.244	1.260	*	*	*	*	0.994	0.927
63	0.945			0.768	0.960	1.150	1.175	*	*	*	*	0.996	0.954
65	0.976			0.694	0.881	1.079	1.085	1.270	*	*	*	0.997	0.972
66.2	0.983			0.655	0.842	1.040	1.060	1.232	*	*	*	0.999	0.986
67	1.000			0.616	0.806	1.000	1.023	1.193	1.330	1.480	*	1.000	1.000
70	1.053				0.693	0.879	0.900	1.075	1.205	1.404	*	1.003	1.044
75	1.168					0.687	0.715	0.875	1.040	1.261	1.476	1.007	1.141

NOTE: *Sensible capacity equals total capacity at conditions shown.

4/22/12

Heating Capacity Corrections

Ent Air DB °F	Heating Corrections		
	Htg Cap	Power	Heat of Ext
45	1.062	0.739	1.158
50	1.050	0.790	1.130
55	1.037	0.842	1.096
60	1.025	0.893	1.064
65	1.012	0.945	1.030
68	1.005	0.976	1.012
70	1.000	1.000	1.000
75	0.987	1.048	0.970
80	0.975	1.099	0.930

11/10/09

Performance Data

036 - 50% Part Load

EWT °F	Flow			HEATING - EAT 70°F							EWT °F	Flow			COOLING - EAT 80/67 °F							
	gpm	PSI	FT	Airflow cfm	HC MBtuh	Power kW	HE MBtuh	LAT °F	COP	HWC MBtuh		gpm	PSI	FT	Airflow cfm	TC MBtuh	SC MBtuh	S/T Ratio	Power kW	HR M Btuh	EER	HWC MBtuh
20	3.0	0.30	0.7	Operation not recommended							20	2.5	0.15	0.4	Operation not recommended							
	4.5	0.70	1.6	Operation not recommended								3.5	0.46	1.1	Operation not recommended							
	5.5	1.09	2.5	550	14.4	1.24	10.2	94.3	3.41	2.2		5.0	0.77	1.8	Operation not recommended							
30	3.0	0.30	0.7	550	16.5	1.30	12.0	97.7	3.71	2.3	30	2.5	0.15	0.3	500	21.4	14.9	0.70	0.56	23.3	38.3	-
				750	16.7	1.32	12.2	90.6	3.69	2.0					650	20.9	14.8	0.71	0.62	23.0	33.9	-
	4.5	0.68	1.6	550	17.3	1.34	12.7	99.1	3.79	2.6		3.5	0.45	1.0	500	21.3	14.9	0.70	0.54	23.2	39.6	-
				750	17.7	1.35	13.1	91.8	3.84	2.2		650	20.7	15.4	0.74	0.65	22.9	31.7	-			
	5.5	1.06	2.4	550	17.7	1.35	13.1	99.7	3.84	2.7		5.0	0.75	1.7	500	21.7	15.3	0.71	0.53	23.5	40.7	-
				750	17.9	1.36	13.3	92.1	3.86	2.2		650	21.0	15.2	0.72	0.61	23.1	34.4	-			
40	3.0	0.29	0.7	550	18.5	1.35	13.9	101.1	4.03	2.5	40	2.5	0.14	0.3	500	24.8	16.3	0.66	0.66	27.1	37.3	-
				750	18.8	1.36	14.2	93.2	4.06	2.2					650	24.7	16.7	0.67	0.74	27.3	33.4	-
	4.5	0.66	1.5	550	19.4	1.38	14.7	102.7	4.13	2.8		3.5	0.44	1.0	500	24.8	16.3	0.66	0.64	27.0	38.7	-
				750	19.8	1.38	15.1	94.5	4.20	2.3		650	24.6	17.0	0.69	0.75	27.2	32.8	-			
	5.5	1.02	2.4	550	19.8	1.39	15.0	103.3	4.15	2.8		5.0	0.73	1.7	500	25.1	16.5	0.66	0.64	27.3	39.4	-
				750	20.1	1.39	15.4	94.9	4.23	2.4		650	24.9	17.0	0.68	0.71	27.3	35.1	-			
50	3.0	0.28	0.6	550	20.5	1.45	15.6	104.6	4.16	2.8	50	2.5	0.14	0.3	500	28.4	17.8	0.63	0.77	31.1	36.7	-
				750	21.0	1.45	16.0	95.9	4.24	2.3					650	28.5	18.5	0.65	0.87	31.5	32.9	-
	4.5	0.64	1.5	550	21.6	1.48	16.5	106.3	4.27	3.0		3.5	0.42	1.0	500	28.5	17.9	0.63	0.75	31.0	38.1	-
				750	22.0	1.48	16.9	97.1	4.36	2.5		650	28.5	18.7	0.66	0.85	31.4	33.5	-			
	5.5	0.99	2.3	550	21.9	1.50	16.8	106.8	4.27	3.1		5.0	0.70	1.6	500	28.8	18.0	0.62	0.74	31.3	38.7	-
				750	22.4	1.49	17.3	97.7	4.41	2.8		650	28.8	18.7	0.65	0.81	31.6	35.6	-			
60	3.0	0.27	0.6	550	23.0	1.42	18.2	108.8	4.75	3.0	60	2.5	0.13	0.3	500	24.1	16.3	0.68	0.83	27.0	29.1	1.0
				750	23.5	1.41	18.7	99.1	4.91	2.5					650	24.7	17.3	0.70	0.91	27.8	27.2	1.0
	4.5	0.62	1.4	550	24.1	1.45	19.2	110.6	4.88	3.2		3.5	0.41	0.9	500	24.2	16.4	0.68	0.80	27.0	30.3	1.1
				750	24.7	1.44	19.8	100.5	5.03	2.7		650	24.8	17.4	0.70	0.88	27.8	28.1	1.1			
	5.5	0.96	2.2	550	24.5	1.47	19.5	111.3	4.89	3.3		5.0	0.68	1.6	500	24.5	16.5	0.67	0.79	27.2	30.9	1.2
				750	25.1	1.45	20.2	101.0	5.08	2.8		650	25.0	17.5	0.70	0.85	27.9	29.4	1.2			
70	3.0	0.26	0.6	550	25.3	1.35	20.7	112.6	5.48	3.2	70	2.5	0.13	0.3	500	20.0	14.8	0.74	0.88	23.0	22.6	1.3
				750	25.9	1.37	21.2	102.0	5.54	2.6					650	18.9	14.7	0.78	0.91	22.0	20.8	1.3
	4.5	0.60	1.4	550	26.4	1.38	21.7	114.4	5.61	3.4		3.5	0.40	0.9	500	20.1	14.9	0.74	0.85	23.0	23.6	1.4
				750	27.2	1.36	22.6	103.6	5.86	2.9		650	21.1	16.1	0.76	0.92	24.2	23.0	1.4			
	5.5	0.93	2.1	550	26.5	1.55	21.2	114.6	5.01	3.5		5.0	0.66	1.5	500	19.9	14.0	0.70	0.86	22.9	23.2	1.5
				750	27.6	1.37	22.9	104.1	5.91	2.9		650	21.1	16.3	0.77	0.89	24.1	23.7	1.5			
80	3.0	0.25	0.6	550	27.2	1.43	22.3	115.8	5.57	3.4	80	2.5	0.13	0.3	500	19.2	14.6	0.76	1.05	22.8	18.3	1.9
				750	28.0	1.39	23.2	104.5	5.88	2.8					650	19.8	15.6	0.79	1.12	23.6	17.6	2.0
	4.5	0.57	1.3	550	28.4	1.46	23.4	117.8	5.69	3.6		3.5	0.38	0.9	500	19.4	14.7	0.76	1.01	22.8	19.1	2.1
				750	29.3	1.43	24.4	106.2	6.03	3.0		650	20.0	15.6	0.78	1.07	23.6	18.6	2.1			
	5.5	0.90	2.1	550	28.9	1.48	23.8	118.6	5.72	3.8		5.0	0.64	1.5	500	19.6	14.8	0.76	1.00	23.0	19.6	2.2
				750	29.8	1.44	24.9	106.8	6.07	3.2		650	20.1	15.7	0.79	1.04	23.6	19.3	2.5			
90	3.0	0.24	0.6	550	29.1	1.44	24.2	119.0	5.92	3.6	90	2.5	0.12	0.3	500	18.5	14.3	0.77	1.22	22.7	15.1	2.6
				750	30.1	1.40	25.3	107.1	6.31	2.9					650	18.6	15.0	0.81	1.30	23.0	14.4	2.6
	4.5	0.55	1.3	550	30.4	1.47	25.3	121.1	6.03	3.8		3.5	0.37	0.9	500	18.6	14.4	0.78	1.18	22.6	15.8	2.7
				750	31.4	1.42	26.6	108.8	6.47	3.2		650	18.8	15.0	0.80	1.23	23.0	15.3	2.7			
	5.5	0.87	2.0	550	30.8	1.49	25.7	121.9	6.06	4.1		5.0	0.61	1.4	500	18.8	14.6	0.78	1.15	22.7	16.3	2.8
				750	32.0	1.44	27.1	109.5	6.51	3.4		650	19.0	15.2	0.80	1.19	23.1	16.0	2.8			
100	3.0	0.23	0.5	Operation not recommended							100	2.5	0.12	0.3	500	16.6	13.5	0.81	1.39	21.4	11.9	3.1
	4.5	0.53	1.2	Operation not recommended								3.5	0.35	0.8	500	16.8	13.6	0.81	1.33	21.3	12.6	3.2
	5.5	0.84	1.9	Operation not recommended								5.0	0.59	1.4	500	16.9	14.2	0.84	1.37	21.6	12.4	3.2
110	3.0	0.22	0.5	Operation not recommended							110	2.5	0.11	0.3	500	14.7	12.6	0.86	1.56	20.1	9.5	3.0
	4.5	0.51	1.2	Operation not recommended								3.5	0.34	0.8	500	14.9	13.1	0.88	1.57	20.3	9.5	3.0
	5.5	0.80	1.9	Operation not recommended								5.0	0.57	1.3	500	15.0	13.0	0.86	1.46	20.0	10.3	3.4
120	3.0	0.22	0.5	Operation not recommended							120	2.5	0.11	0.2	500	13.2	11.3	0.86	1.81	19.4	7.3	4.3
	4.5	0.49	1.1	Operation not recommended								3.5	0.33	0.8	500	13.3	11.5	0.86	1.74	19.3	7.7	4.4
	5.5	0.77	1.8	Operation not recommended								5.0	0.55	1.3	500	13.6	11.9	0.88	1.67	19.3	8.1	4.6
													650	13.3	11.8	0.89	1.69	19.1	7.9	4.6		

Performance capacities shown in thousands of Btuh.

7/30/15

Performance Data cont.

048 - 100% Full Load

EWT °F	WPD			HEATING - EAT 70°F							EWT °F	WPD			COOLING - EAT 80/67 °F																					
	Flow gpm	PSI	FT	Airflow cfm	HC mBtuh	Power kW	HE MBtuh	LAT °F	COP	HWC MBtuh		Flow gpm	PSI	FT	Airflow cfm	TC MBtuh	SC MBtuh	S/T Ratio	Power kW	HR MBtuh	EER	HWC MBtuh														
20	6.5	1.40	3.2	Operation not recommended							20	5.5	1.05	2.4	Operation not recommended																					
	10.0	2.85	6.6									8.0	2.00	4.6																						
	13.5	4.79	11.1	1500	40.6	3.67	28.1	95.1	3.24	6.05		10.5	2.94	6.8	1000	52.6	36.3	0.69	1.33	57.1	39.7	-														
30	6.5	1.36	3.2	1500	44.9	3.86	31.7	97.7	3.41	6.6	30	5.5	1.02	2.4	1000	54.4	37.4	0.69	1.56	59.7	34.9	-														
		1800	45.8	3.93	32.4	93.5	3.41	6.1	1400	51.5			36.3	0.70	1.48	56.6	34.8	-																		
	10.0	2.77	6.4	1500	45.3	3.90	32.0	98.0	3.40	6.8	8.0	1.94	4.5	1000	52.5	36.2	0.69	1.28	56.9	41.0	-															
		1800	46.2	3.97	32.6	93.8	3.41	6.1	1400	50.9	37.3	0.73	1.55	56.1	32.8	-																				
	13.5	4.65	10.7	1500	45.9	4.11	31.9	98.4	3.27	6.9	10.5	2.85	6.6	1000	52.7	36.5	0.69	1.29	57.1	41.0	-															
		1800	47.6	4.07	33.7	94.5	3.43	6.3	1400	51.7	36.9	0.71	1.45	56.6	35.7	-																				
40	6.5	1.32	3.1	1500	49.7	3.94	36.3	100.7	3.70	7.0	40	5.5	0.99	2.3	1000	54.4	37.4	0.69	1.56	59.7	34.9	-														
		1800	50.4	4.00	36.8	95.9	3.70	6.2	1400	54.3			38.3	0.71	1.75	60.2	31.1	-																		
	10.0	2.69	6.2	1500	50.2	3.95	36.7	101.0	3.72	7.3	8.0	1.88	4.3	1000	54.5	37.4	0.69	1.50	59.6	36.2	-															
		1800	51.4	4.04	37.6	96.4	3.73	6.4	1400	54.0	39.0	0.72	1.76	60.0	30.6	-																				
	13.5	4.51	10.4	1500	51.6	4.04	37.8	101.8	3.74	7.5	10.5	2.77	6.4	1000	54.9	37.6	0.69	1.50	60.0	36.5	-															
		1800	52.6	4.11	38.6	97.1	3.75	6.5	1400	54.6	38.9	0.71	1.67	60.3	32.8	-																				
50	6.5	1.28	3.0	1500	58.0	4.04	44.2	105.8	4.20	7.5	50	5.5	0.96	2.2	1000	56.7	38.9	0.69	1.80	62.9	31.5	-														
		1800	58.6	4.09	44.6	100.1	4.20	7.0	1400	56.9			40.4	0.71	2.01	63.8	28.3	-																		
	10.0	2.60	6.0	1500	58.6	4.03	44.8	106.2	4.26	8.2	8.0	1.82	4.2	1000	56.9	39.0	0.69	1.73	62.8	32.8	-															
		1800	60.1	4.13	46.0	100.9	4.27	7.2	1400	56.9	40.8	0.72	1.97	63.7	28.8	-																				
	13.5	4.37	10.1	1500	59.9	4.16	45.7	107.0	4.22	8.4	10.5	2.68	6.2	1000	57.4	39.2	0.68	1.72	63.3	33.3	-															
		1800	61.2	4.17	47.0	101.5	4.30	8.6	1400	57.5	40.8	0.71	1.88	63.9	30.6	-																				
60	6.5	1.24	2.9	1500	63.2	3.99	49.6	109.0	4.64	7.6	60	5.5	0.93	2.2	1000	52.7	36.9	0.70	2.11	60.0	24.9	2.6														
		1800	64.2	4.03	50.5	103.0	4.67	7.1	1400	53.9			39.2	0.73	2.32	61.8	23.3	2.8																		
	10.0	2.52	5.8	1500	64.7	4.01	51.0	110.0	4.73	8.4	8.0	1.76	4.1	1000	52.9	37.1	0.70	2.04	59.9	26.0	2.9															
		1800	65.7	4.07	51.8	103.8	4.73	7.2	1400	54.2	39.4	0.73	2.25	61.9	24.1	2.9																				
	13.5	4.23	9.8	1500	66.2	4.08	52.2	110.8	4.75	8.6	10.5	2.60	6.0	1000	53.5	37.3	0.70	2.02	60.3	26.5	2.8															
		1800	67.5	4.13	53.4	104.7	4.79	7.4	1400	54.5	39.6	0.73	2.17	61.9	25.2	3.0																				
70	6.5	1.20	2.8	1500	67.6	4.02	53.9	111.7	4.93	8.1	70	5.5	0.90	2.1	1000	48.8	35.0	0.72	2.44	57.1	20.0	3.4														
		1800	68.3	3.94	54.9	105.1	5.08	7.5	1400	47.6			34.4	0.72	2.52	56.2	18.9	3.7																		
	10.0	2.44	5.6	1500	71.3	4.00	57.7	114.0	5.23	8.6	8.0	1.71	3.9	1000	49.0	35.2	0.72	2.34	57.0	20.9	3.9															
		1800	71.6	4.02	57.9	106.9	5.23	7.9	1400	51.5	38.0	0.74	2.52	60.1	20.4	3.9																				
	13.5	4.09	9.5	1500	72.6	4.61	56.9	114.8	4.62	9.4	10.5	2.51	5.8	1000	50.4	34.9	0.69	2.30	58.3	21.9	3.9															
		1800	74.3	4.10	60.3	108.2	5.31	8.2	1400	51.5	38.4	0.75	2.45	59.8	21.0	4.1																				
80	6.5	1.16	2.7	1500	74.9	4.01	61.3	116.3	5.48	9.0	80	5.5	0.87	2.0	1000	45.8	34.2	0.75	2.84	55.5	16.1	5.4														
		1800	76.3	4.01	62.6	109.3	5.57	7.7	1400	47.0			36.6	0.78	3.03	57.3	15.5	5.4																		
	10.0	2.35	5.4	1500	78.3	4.08	64.4	118.3	5.63	9.5	8.0	1.65	3.8	1000	46.1	34.5	0.75	2.73	55.4	16.9	5.7															
		1800	79.0	4.03	65.2	110.6	5.74	7.9	1400	47.5	36.6	0.77	2.88	57.3	16.5	5.7																				
	13.5	3.95	9.1	1500	79.6	4.13	65.5	119.1	5.65	9.6	10.5	2.42	5.6	1000	46.5	34.8	0.75	2.68	55.7	17.3	5.9															
		1800	81.1	4.16	67.0	111.7	5.72	9.0	1400	47.7	37.0	0.77	2.80	57.2	17.0	5.9																				
90	6.5	1.12	2.6	1500	81.0	4.04	67.3	120.0	5.88	9.7	90	5.5	0.84	1.9	1000	42.7	33.4	0.78	3.24	53.8	13.2	6.7														
		1800	82.3	4.03	68.6	112.4	5.99	8.6	1400	43.0			35.1	0.82	3.43	54.7	12.5	6.6																		
	10.0	2.27	5.2	1500	85.3	4.13	71.2	122.7	6.05	9.5	8.0	1.59	3.7	1000	43.0	33.7	0.78	3.11	53.6	13.8	7.0															
		1800	86.3	4.03	72.6	114.4	6.28	8.9	1400	43.5	35.1	0.81	3.24	54.5	13.4	7.0																				
	13.5	3.81	8.8	1500	85.7	4.35	70.9	122.9	5.77	10.4	10.5	2.34	5.4	1000	43.5	34.1	0.78	3.06	53.9	14.2	7.3															
		1800	88.0	4.20	73.7	115.3	6.14	9.7	1400	43.9	35.5	0.81	3.15	54.6	13.9	7.4																				
100	6.5	1.08	2.5	Operation not recommended							100	5.5	0.81	1.9	1000	40.8	32.5	0.80	3.78	53.7	10.8	8.9														
	10.0	2.19	5.1									8.0	1.53	3.5	1000	41.1	34.1	0.83	3.90	54.4	10.5	8.8														
	13.5	3.67	8.5									10.5	2.25	5.2	1000	41.1	32.9	0.80	3.63	53.5	11.3	9.3														
110	6.5	1.04	2.4								Operation not recommended							110	5.5	0.78	1.8	1000	38.8	31.7	0.82	4.32	53.6	9.0	10.6							
		1800	39.2																	33.0	0.84	4.37	54.1	9.0	10.5											
	10.0	2.11	4.9															8.0	1.47	3.4	1000	39.2	32.1	0.82	4.14	53.3	9.5	11.1								
		1800	39.6															33.5	0.85	4.18	53.9	9.5	11.1													
	13.5	3.53	8.2															10.5	2.17	5.0	1000	39.6	32.5	0.82	4.04	53.4	9.8	11.6								
		1800	40.0															33.9	0.85	4.08	53.9	9.8	10.5													
120	6.5	1.00	2.3															Operation not recommended							120	5.5	0.75	1.7	1000	36.1	29.1	0.80	5.02	53.2	7.2	12.8
		1800	35.6																								29.5	0.83	4.89	52.3	7.3	13.1				
	10.0	2.02	4.7																						8.0	1.42	3.3	1000	36.5	29.5	0.81	4.81	52.9	7.6	13.2	
		1800	35.8	30.1	0.84	4.82	52.2	7.4	13.6																											
	13.5	3.39	7.8	10.5	2.08	4.8	1000	36.6	30.1	0.82															4.68	52.6	7.8	13.8								
		1800	36.4	30.4	0.83	4.68	52.4	7.8	14.0																											

Performance capacities shown in thousands of Btuh.

7/30/15

Wiring Schematics

Aurora Variable Speed

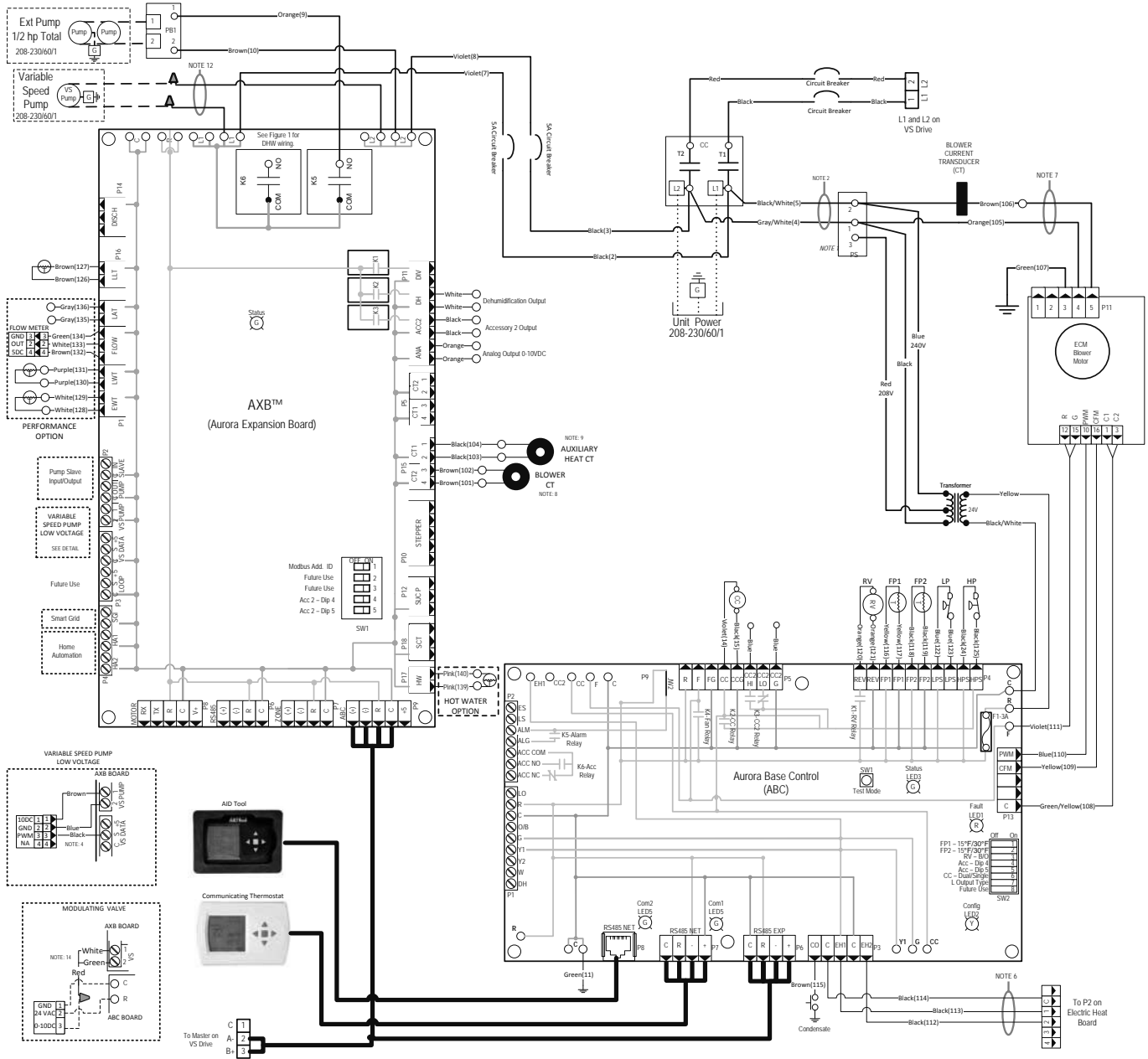

Wiring Schematics cont.

Aurora Variable Speed cont.

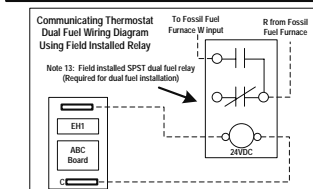
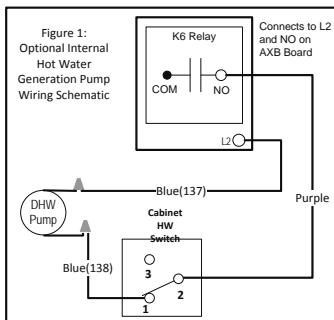
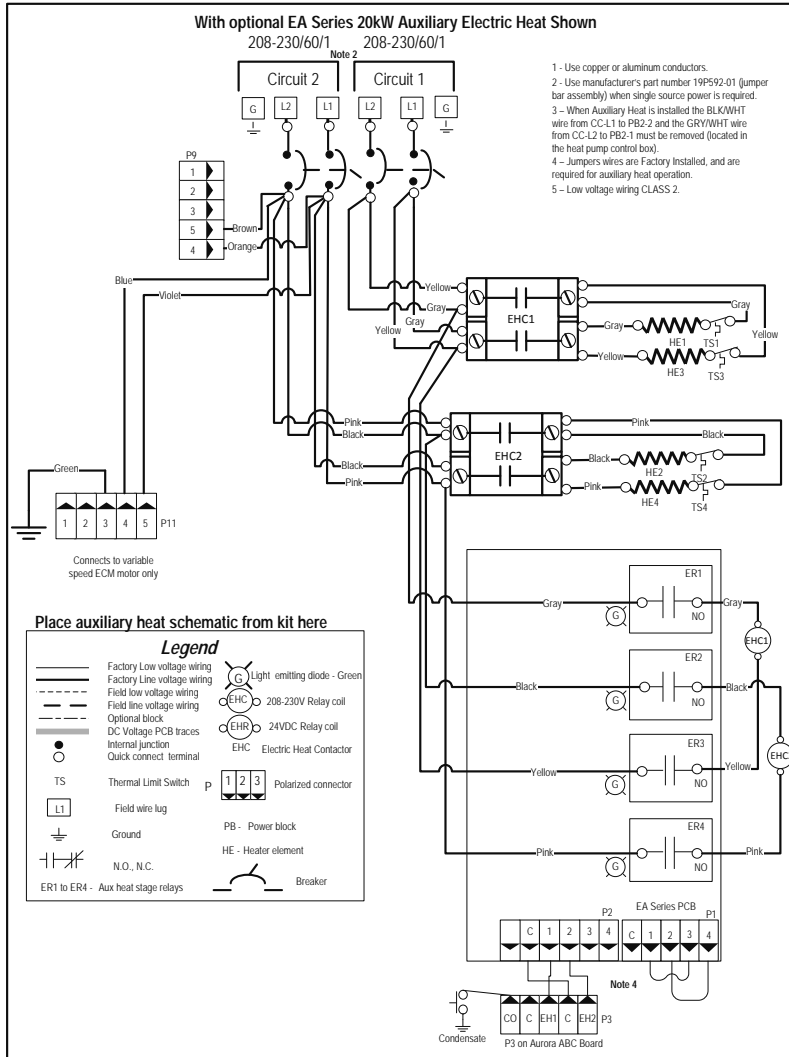

- Notes**
- 1 - Switch blue and red wires for 208V operation.
 - 2 - The blk/wh and gray/wh wires are removed when Aux Heat is installed
 - 3 - Use manufacturer's part number 19P592-01 (jumper bar assembly) when single source power is required.
 - 4 - Variable Speed pump low voltage harness provided with Variable Speed Flow Center.
 - 5 - Low voltage wiring CLASS 2.
 - 6 - Wires provided for Auxiliary Heat low voltage control. Wires are secured at blower.
 - 7 - When Auxiliary Heat is field installed the harness will then be connected to the auxiliary heat unit. The auxiliary heat unit will then power the blower. Refer to EASE/EAM/EAL Auxiliary Heat kit installation instructions.
 - 8 - Brown blower power wire routed through Current Transducer two times.
 - 9 - Field Connected: Refer to Installation Manual and Auxiliary Heat Instructions for Current Transducer installation.
 - 10 - Communication cable routed through Ferrite Toroid four times.
 - 11 - Compressor power cable routed through Ferrite Toroid three times.
 - 12 - Variable speed pump power wires to connect the pump to L1 and L2 on the AXB board are provided with Variable Speed Flow Center.
 - 13 - Field installed SPST relay required for dual fuel installation.
 - 14 - Wiring harness supplied with valve.

Wiring Schematics cont.

Aurora Variable Speed Drive/EEV Wiring

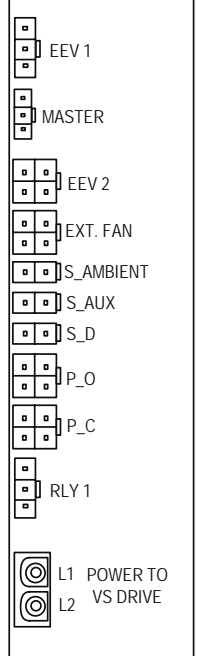
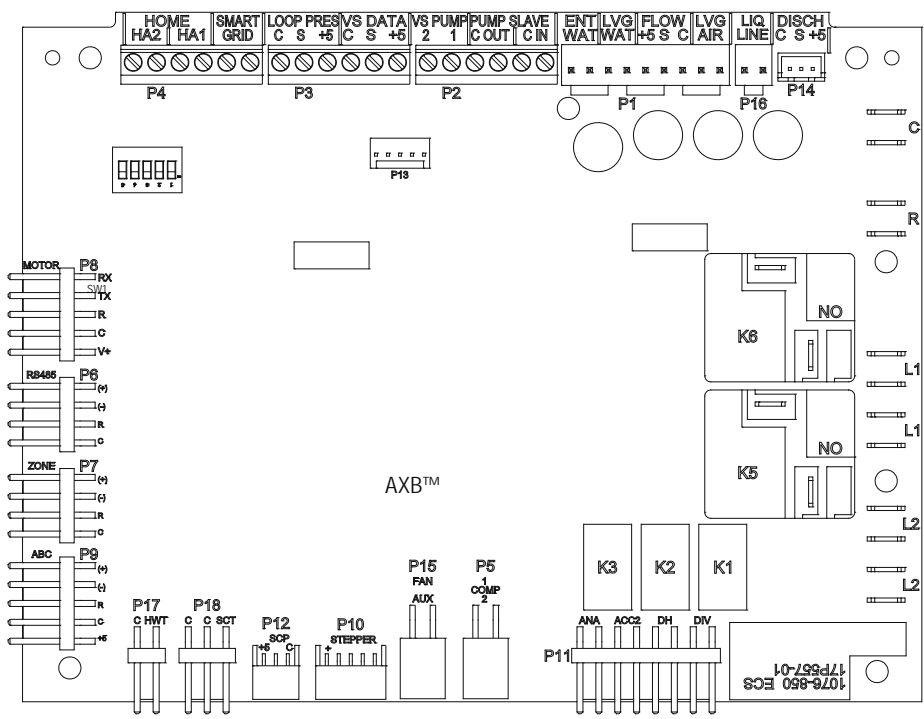
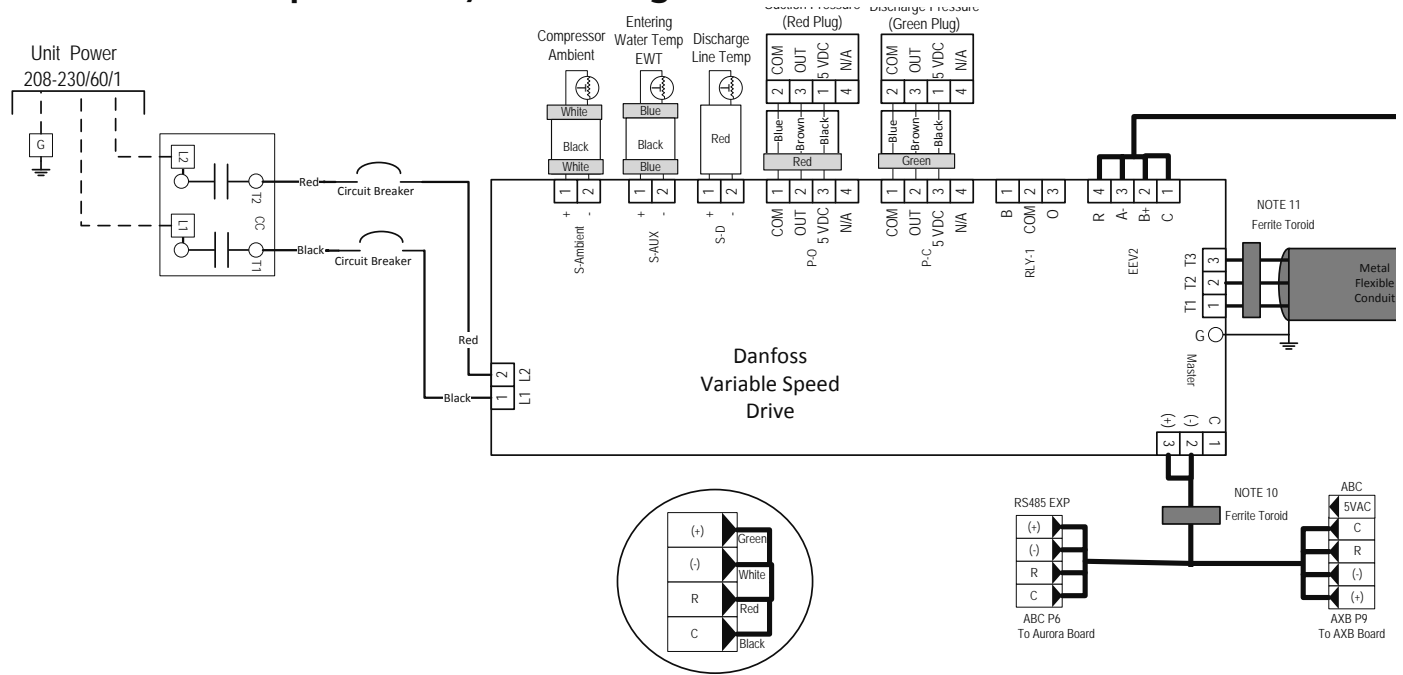

VARIABLE SPEED DRIVE END VIEWS

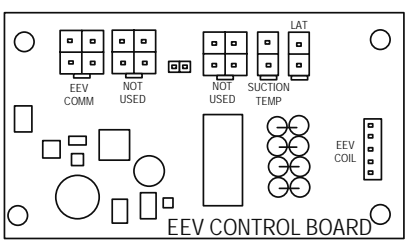
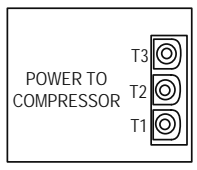

Wiring Schematics cont.

Aurora Variable Speed Drive/EEV Wiring cont.

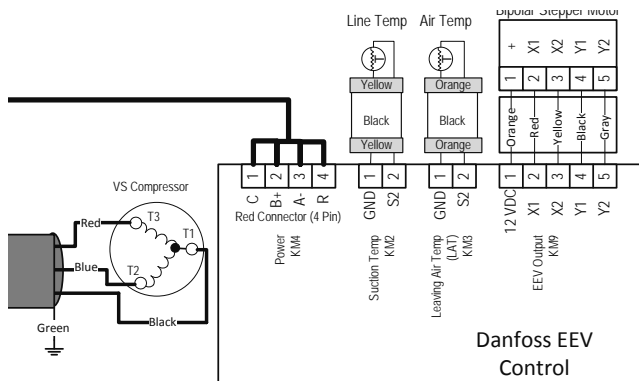

Legend

	Factory Low voltage wiring		Thermistor
	Factory Line voltage wiring		Light emitting diode - Green
	Field low voltage wiring		Relay coil
	Field line voltage wiring		Capacitor w/ bleed resistor
	Optional block		Switch - Condensate overflow
	DC Voltage PCB traces		Switch - High pressure
	Junction		Switch - Low pressure
	Quick connect terminal		Polarized connector
	Wire nut		Current Transducer (CT)
	Field wire lug		
	Ground		
	Relay Contacts N.O., N.C.		
	Fuse		
	Color identification tape on wire.		

CC - Compressor Contactor	PB1, PB2 - Power blocks
CO - Condensate overflow sensor	PS - Power strip
K5 - DHW pump relay	RV - Reversing Valve coil
K6 - Loop pump relay	SW1 - DIP package 5 position AXB
CR3 - PSC Fan Speed Relay	SW1 - TEST MODE ABC Board
CR4 - PSC Fan Power Relay	SW2 - DIP package 8 position ABC Board
CS - Compressor Solenoid	TS - Thermal limit switch
F1 and F2 - Fuses	HWL - Hot water limit sensor
HE - Heater element	SC - Start Contactor
HP - High pressure switch	SR - Start Relay
ER1 to ER4 - Aux heat stage relays	WCL - Water Coil Limit Sensor
LP - Low pressure switch	

Aurora LED Flash Codes			
Slow Flash	1 second on and 1 second off		
Fast Flash	100 milliseconds on and 100 milliseconds off		
Flash Code	100 milliseconds on and 400 milliseconds off with a 2 second pause before repeating		
Fault LED (LED 1, Red)		Random Start Delay (Alternating Colors)	
Normal Mode	OFF	Status LED (LED 1, Green)	Fast Flash
Input Fault Lockout	Flash Code 1	Configuration LED (LED 2, Yellow)	Fast Flash
High Pressure Lockout	Flash Code 2	Fault LED (LED 3, Red)	Fast Flash
Low Pressure Lockout	Flash Code 3	Configuration LED (LED 2, Yellow)	
Freeze Detection - FP2	Flash Code 4	No Software Override	OFF
Freeze Detection - FP1	Flash Code 5	DIP Switch Override	Slow Flash
Reserved	Flash Code 6	Status LED (LED 3, Green)	
Condensate Overflow Lockout	Flash Code 7	Normal Mode	ON
Over/Under Voltage Shutdown	Flash Code 8	Control is Non - Functional	OFF
Future Use	Flash Code 9	Test Mode	Slow Flash
Compressor Monitoring	Flash Code 10	Lockout Active	Fast Flash
Fault - FP1 and FP2 Sensor Error	Flash Code 11	Dehumidification Mode	Flash Code 2
Future Use	Flash Code 12	Future Use	Flash Code 3
Non-Critical AXB Sensor Error	Flash Code 13	Future Use	Flash Code 4
Critical AXB Sensor Error	Flash Code 14	Load Shed	Flash Code 5
Alarm - Hot Water	Flash Code 15	ESD	Flash Code 6
Fault Variable Speed Pump	Flash Code 16	Future Use	Flash Code 7
Future Use	Flash Code 17	Fault LED (LED 1, Red) Cont.	
Non-Critical Communication Error	Flash Code 18	Safe Mode - Ambient Temperature Sensor	Flash Code 49
Fault - Critical Communication Error	Flash Code 19	Fault - Discharge Temperature Sensor	Flash Code 51
Alarm - Low Loop Pressure	Flash Code 21	Fault - Suction Pressure Sensor	Flash Code 52
Fault - Communication ECM Fan Motor Error	Flash Code 22	Fault - Condensing Pressure Sensor	Flash Code 53
Alarm - Home Automation 1	Flash Code 23	Fault - Low Supply Voltage	Flash Code 54
Alarm - Home Automation 2	Flash Code 24	Fault - Compressor Out of Envelope	Flash Code 55
Fault - EEV Error	Flash Code 25	Fault - Over Current	Flash Code 56
Derate - Drive Temperature	Flash Code 41	Fault - Over/Under Voltage	Flash Code 57
Derate - High Discharge Temperature	Flash Code 42	Fault - High Drive Temperature	Flash Code 58
Derate - Low Suction Temperature	Flash Code 43	Fault - Drive Internal Error MOC/AOC	Flash Code 59
Derate - Low Condensing Pressure	Flash Code 44	Fault - Multiple Safe Modes	Flash Code 61
Derate - High Condensing Pressure	Flash Code 45	Fault - Loss of Charge	Flash Code 71
Derate - Outer Power Limit	Flash Code 46	Safe Mode - Suction Temperature Sensor	Flash Code 72
Safe Mode - EEV (Indoor) Communication	Flash Code 47	Safe Mode - LAT Temperature Sensor	Flash Code 73
Safe Mode - EEV (Outdoor) Communication	Flash Code 48	Safe Mode - Max Operating Pressure	Flash Code 74

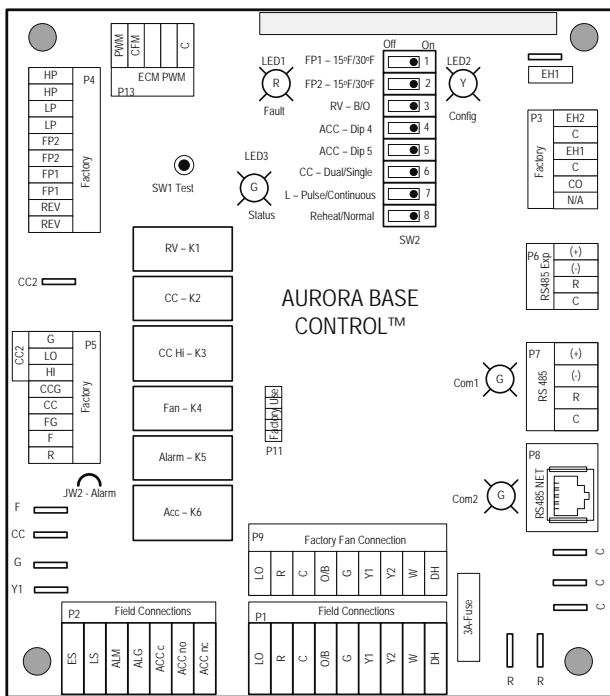

AXB Accessory 2 DIP Settings		
SW1-4	SW1-5	DESCRIPTION
ON	ON	Cycles with Blower
OFF	ON	Cycles with CC first stage compressor or compressor spd 1-12
ON	OFF	Cycles with CC2 second stage of compressor or comp spd 7-12
OFF	OFF	Cycles with DH from ABC board

ABC SW2 Accessory Relay		
DESCRIPTION	SW2-4	SW2-5
Cycle with Blower	ON	ON
Cycle with Compressor	OFF	OFF
Water Valve Slow Opening	ON	OFF
Cycle with Comm. T-stat Hum Cmd	OFF	ON

Engineering Guide Specifications

General

Furnish and install York Affinity Variable Speed Series Water Source Heat Pumps, as indicated on the plans. Equipment shall be completely assembled, piped and internally wired. Capacities and characteristics as listed in the schedule and the specifications that follow. The reverse cycle heating/ cooling units shall be either suspended type with horizontal air inlet and discharge or floor mounted type with horizontal air inlet and vertical upflow, downflow, or rear air discharge. Units shall be AHRI/ISO 13256-1 certified and listed by a nationally recognized safety-testing laboratory or agency, such as ETL Testing Laboratory. Each unit shall be computer run-tested at the factory with conditioned water and operation verified to catalog data. Each unit shall be mounted on a pallet and shipped in a corrugated box or stretch-wrapped. The units shall be designed to operate with entering liquid temperature between 20°F and 120°F [-6.7°C and 48.9°C].

Casing and Cabinet

The cabinet shall be fabricated from heavy-gauge galvanized steel and finished with corrosion-resistant powder coating. This corrosion protection system shall meet the stringent 1000 hour salt spray test per ASTM B117. The interior shall be insulated with 1/2-inch thick, multi-density, cleanable aluminum foil coated glass fiber with edges sealed or tucked under flanges to prevent the introduction of glass fibers into the discharge air. Standard cabinet panel insulation must meet NFPA 90A requirements, air erosion and mold growth limits of UL- 181, stringent fungal resistance test per ASTM-C1071 and ASTM G21, and shall meet zero level bacteria growth per ASTM G22. Unit insulation must meet these stringent requirements or unit(s) will not be accepted.

One (horizontal) to two (vertical) blower and three compressor compartment access panels shall be 'lift-out' removable with supply and return ductwork in place. The front access panel shall be lift-out to provide easy access to the electrical/compressor section. The control box shall be hinged and removable to allow easy access to the compressor. The internal component layout shall provide for service access from the front side for restricted installations.

A duct collar shall be provided on the supply air opening. Standard size 2 in. [5.1 cm] MERV 11 pleated filter shall be provided with each unit. Vertical and horizontal units shall have a return air filter rack/duct collar which is field convertible from 2 in. [5.1 cm] to 1 in. [2.5 cm]. The upflow vertical units shall have a removable insulated divider panel between the air handling section and the compressor section to minimize the transmission of compressor noise and to permit operational service testing without air bypass. Vertical units shall be supplied with left or right horizontal air inlet and top, bottom, or rear vertical air discharge. Horizontal units shall be supplied with left or right air inlet and side or end air discharge.

The compressor shall be double isolation mounted using selected durometer grommets to provide vibration free compressor mounting.

The drain pan shall be of plastic construction to inhibit corrosion and bacterial growth. Drain outlet shall be located on pan as to allow complete and unobstructed drainage of condensate. The unit as standard will be supplied with solid-state electronic condensate overflow protection. Mechanical float switches WILL NOT be accepted. Vertical units shall be furnished with a PVC slip condensate drain connection and an internal factory installed condensate trap.

Refrigerant Circuit

All units shall contain a sealed refrigerant circuit including a hermetic motor-compressor, discharge line muffler, bidirectional electronic expansion valve, finned tube air-to-refrigerant heat exchanger, reversing valve, coaxial tube water-to-refrigerant heat exchanger, optional hot water generator coil, and service ports. Compressors shall be high-efficiency variable speed scroll type designed for heat pump duty and mounted on double vibration isolators.

Compressor motors shall be permanent magnet type. The double electro-coated air coil shall be sized for low-face velocity and constructed of patented 11 element lanced aluminum fins bonded to rifled copper tubes in a staggered pattern not less than three rows deep for enhanced performance. All models shall include discharge mufflers to help quiet compressor discharge gas pulsations.

Refrigerant to air heat exchangers shall utilize rifled copper tube construction rated to withstand 600 psig (4135 kPa) refrigerant working pressure. Refrigerant to water heat exchangers shall be of copper (cupronickel optional) inner water tube and steel refrigerant outer tube design, rated to withstand 600 psig (4135 kPa) working refrigerant pressure and 450 psig (3101 kPa) working water pressure. An electronic expansion valve shall provide proper superheat over the entire liquid temperature range with minimal "hunting." The valve shall operate bidirectionally without the use of check valves.

All units shall have the source coaxial tube refrigerant-to water heat exchanger and the optional hot water generator coil coated with ThermaShield insulation. Refrigerant suction lines shall be insulated to prevent condensation at low liquid temperatures.

Blower Motor and Assembly

The blower shall be a direct drive centrifugal type with a dynamically balanced wheel. The housing and wheel shall be designed for quiet low outlet velocity operation. The blower housing shall be removable from the unit without disconnecting the supply air ductwork for servicing of the blower motor. The blower motor shall be a variable-speed ECM type. The ECM blower motor shall be soft starting, shall maintain constant cfm over its operating static range, and shall provide 12 cfm settings. The blower motor shall be isolated from the housing by rubber grommets. The motor shall be permanently lubricated, have thermostatic overload protection and be long-life ball bearing type.

Engineering Guide Specifications cont.

Electrical

A control box shall be located within the unit compressor compartment and shall contain a 75VA transformer, 24 Volt activated, 2 pole compressor contactor, circuit breakers for protecting loop pumps and compressor drive, removable terminal block for thermostat wiring, variable speed compressor drive and solid-state controller for complete unit operation. Electromechanical operation WILL NOT be accepted. Units shall be name-plated for use with time delay fuses or HACR circuit breakers. Unit controls shall be communicating type and provide heating or cooling as required by the remote thermostat/sensor. An Aurora Advanced VS Control, a microprocessor based controller, interfaces with a digital communicating thermostat to monitor and control unit operation shall be provided. The control shall provide operational sequencing, blower speed control, blower failure, high and low pressure switch monitoring, freeze detection, hot water limit thermistor sensing, condensate overflow sensing, auxiliary heat staging, lockout mode control, hot water and loop pump control, LED status and fault indicators, fault memory, field selectable options, compressor envelope management, energy consumption measurement, and accessory output. The fault signals shall be plain English text and displayed on the thermostat.

The Aurora Advanced VS Control shall also feature an On Peak input signal for utility controlled demand programs, intelligent hot water generation with user adjustable temperature limit, loop pump slaving for multiple units driving a common flow center and up to two optional home automation inputs to drive dedicated alarms for sump pump, security system, and smoke/CO2 or dirty air filter sensors. As standard, the energy and refrigerant monitoring kits will provide real time data including total power consumption, refrigerant superheat and subcooling. Optional performance monitoring kit to provide real time data including, entering and leaving water temperature, flow rate and heat of extraction/rejection capacity data. The capability for communicating to advanced zoning packages with up to six zones shall also be provided with complete fault and information display on the zoning MasterStat.

A detachable terminal block with screw terminals will be provided for field control wiring. All units shall have knockouts for entrance of low and line voltage wiring. The blower motor and control box shall be harness plug wired for easy removal.

An optional Aurora Interface Diagnostic (AID) Tool shall communicate with the Aurora control allowing quick and easy access to setup, monitoring, and troubleshooting of any Aurora control. The device shall include the features of ECM airflow setup, VS pump and modulating water valve setup, fault description and history, manual operation capability, sensor readings, timings, and other diagnostic tools.

Piping

Supply and return water connections shall be 1 in. [25.4 mm] FPT brass swivel fittings, which provide a union and eliminate the need for pipe wrenches and sealants when making field connections. The optional hot water generator shall have sweat type connections. All source water piping shall be insulated to prevent condensation at low liquid temperatures. On the vertical units, the condensate connection shall be a 3/4 in. [19.1 mm] PVC socket with internally-trapped hose that can be routed to front or side locations.

Hanger Kit

(field-installed horizontal units only)

The hanger kit shall consist of galvanized steel brackets, bolts, lock washers, and isolators and shall be designed to fasten to the unit bottom panel for suspension from 3/8- inch threaded rods. All unit size shall include six brackets hanging brackets.

Options and Accessories

Cupronickel Heat Exchanger

An optional cupronickel water-to-refrigerant heat exchanger shall be provided.

Hot Water Generator

An optional ThermaShield coated heat reclaiming hot water generator coil of vented double-wall copper construction suitable for potable water shall be provided. The coil and hot water circulating pump shall be factory mounted inside the unit with integral electronic high limit temperature monitoring and external on/off switch. Hot water set point is selectable through the AID Tool.

Thermostat (field-installed)

A communicating auto-changeover electronic digital thermostat shall be provided. The thermostat shall offer variable speed heating and cooling staging with precise temperature control. An OFF-HEAT-AUTO-COOL-EMERG system switch, OFF-AUTO-INTERMITTENT blower switch, and indicating display shall be provided. The thermostat shall display in °F or °C. The thermostat shall provide real time energy consumption data of the unit.

Color Touchscreen Thermostat (field-installed)

A color touchscreen communicating auto-changeover electronic digital thermostat shall be provided. The thermostat shall offer variable speed heating and cooling staging with precise temperature control. An OFF-HEAT-AUTO-COOL-EMERG system switch, OFF-AUTO-INTERMITTENT blower switch, and indicating display shall be provided. The thermostat shall display in °F or °C. The thermostat shall provide real time and historical energy consumption data of the unit.

Engineering Guide Specifications cont.

Electronic Air Cleaner (field-installed)

A 1 in. [25 mm] electronic air cleaner, cleanable 97% efficiency at 0.3 microns and larger, shall be provided in lieu of the standard throwaway filter. The initial pressure drop across the filter shall not exceed 0.2 in. w.g. at 300 fpm face velocity.

AlpinePure MERV 13 Filter (field-installed)

A 2 in. [50 mm] thick MERV 13 filter shall be provided in lieu of the standard filter and fits the factory filter rack. The filter maintains MERV 13 rating in full ASHRAE 52.2 independent testing as required for LEED® certification. Helps fulfill a full credit under the LEED rating system.

AlpinePure Drain Pan Treatment (field-installed)

Provides dependable, sustained time-release protection from slime build-up and foul smelling odors in the drain pan. Also adds a light, pleasant scent to the air.

Earth Loop Flow Center (field-installed)

A self-contained module shall provide all liquid flow, fill and connection requirements for ground source closed loop systems up to 20 gpm. The pumps shall be wired to a power block located in the nearest unit. The heat pump units shall contain low voltage pump slaving control so that two units may share one flow center.

Auxiliary Heater (field-installed)

An electric resistance heater shall provide supplemental and/or emergency heating capability. Vertical units shall have the control panel and resistance heater coil assembly mounted internally. For horizontal units, the control panel shall be mounted internally while the resistance heater coil assembly shall be mounted externally. A low voltage plug shall be provided in each unit for quick auxiliary heat connection. The heater shall operate in sequenced stages as controlled by the unit's microprocessor. The heater shall feed line voltage power to the unit blower and transformer to provide emergency heat capability in the event of an open compressor circuit breaker.

Revision Guide

Pages:	Description:	Date:	By:
All	Misc. Updates	04 Jan 2017	MA
All	Misc Updates, Performance Data Updated	12 Aug 2016	MA
All	Various Updates for Electric Heating Change	23 April 2014	MA
All	First Published	01 Jul 2013	DS



Product: **Affinity Series**
Type: Variable Speed Geothermal Heat Pumps
Size: 3-5 Tons

Document Type: Specification Catalog
Part Number: SC2700AK6
Release Date: 01/17