



Heating and Air Conditioning

SPECIFICATION CATALOG

AFFINITY

**COMMERCIAL GEOTHERMAL/
WATER SOURCE HEAT PUMPS
SINGLE CAPACITY HYDRONIC**

MODELS:

YHSW018 - 075

(1.5 THRU 6 NOMINAL TONS)



Intertek

Due to continuous product improvement, specifications are subject to change without notice.

Visit us on the web at www.yorkgeothermal.com

Additional rating information can found at
www.ahrirectory.org

FOR DISTRIBUTION USE ONLY - NOT TO BE USED AT POINT OF RETAIL SALE

Table of Contents

Model Nomenclature	4
The Hydronic Unit.....	5-6
Inside the Hydronic Unit	7
Water Quality	8
The Aurora Base Control System	9-12
Application Notes.....	13-19
Dimensional Data	20
Physical Data	21
Electrical Data	21
Antifreeze Correction	22
AHRI/ISO 13256-2 Performance Ratings	23
Pressure Drop	24
Reference Calculations	25
Legend and Notes	25
Performance Data.....	26-39
Wiring Schematics	40-45
Accessories and Options.....	46-47
Engineering Guide Specifications	48-49
Revision Guide.....	51

Model Nomenclature

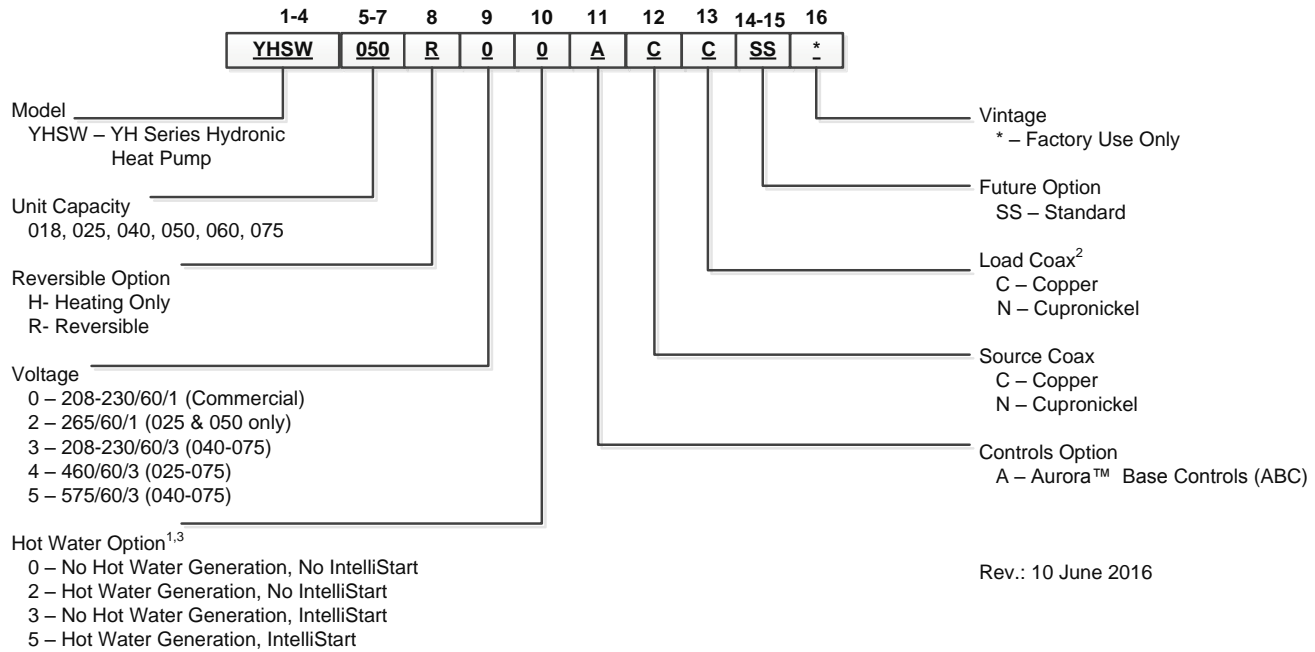

Rev.: 10 June 2016

NOTES: 1 – Available on 040, 050, 060, and 075 only. Hot water generator requires field installed external pump kit.
 2 – 018 and 025 heating only models are available only with copper double wall vented load coax for potable water, and are not designed to be converted to dedicated cooling units.
 3 – IntelliStart not available on 265/60/1 and 575/60/3 voltages.



Affinity Series hydronic units are Safety listed under UL1995 thru ETL and performance tested in accordance with standard AHRI/ISO 13256-2. AHRI does not currently certify water-to-water products under AHRI/ISO 13256-2.

The Single Hydronic Series

Features

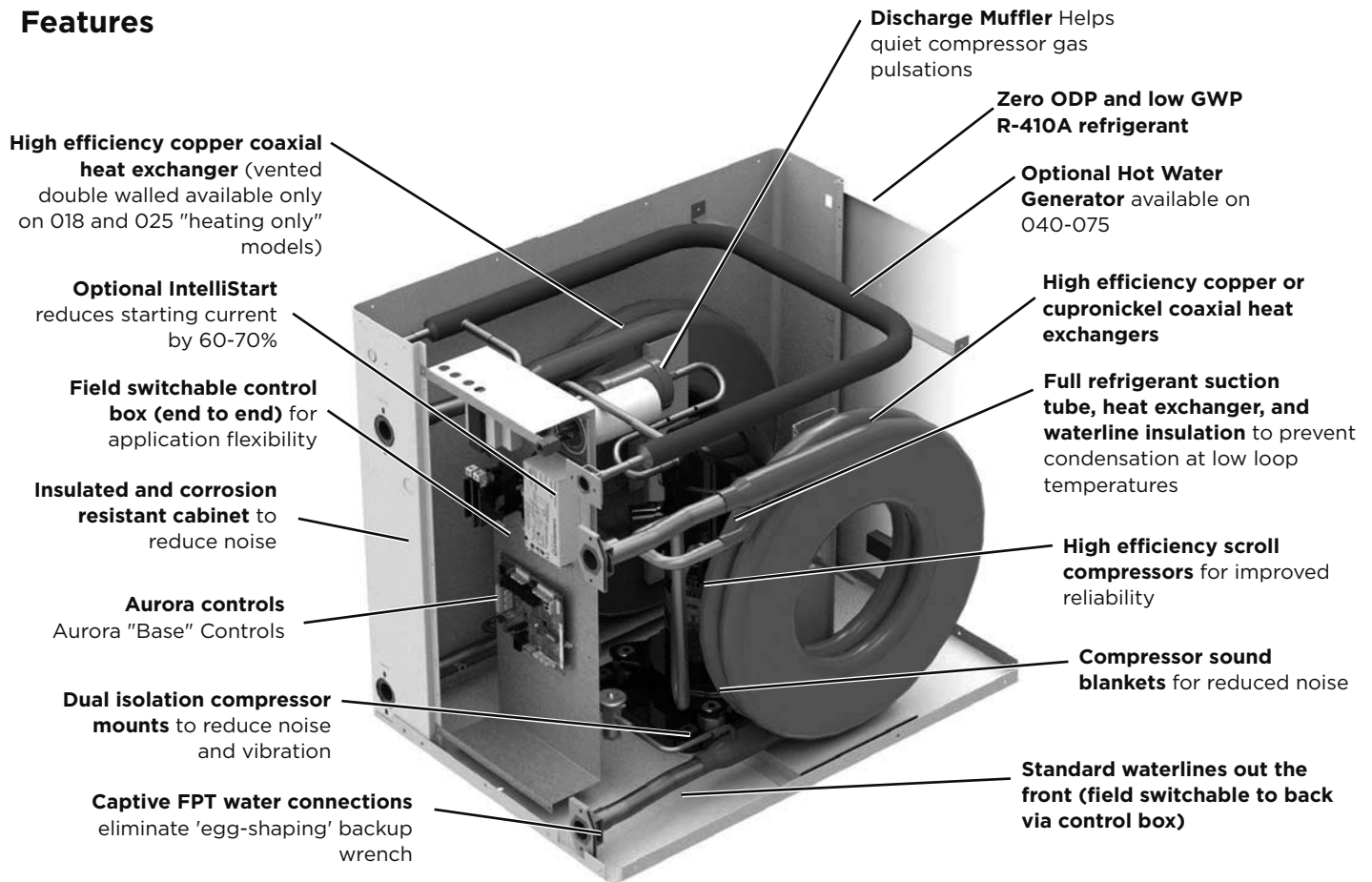

What's New?

- **Aurora™ Communicating Control Features**
 - *Traditional Safety Sensors:* HP, LP, condensate overflow, freeze detection loop, freeze detection load.
 - *Communicating Modular Design:* Communicating modular design for flexibility and expandability

Single Hydronic Series cont.

High Efficiency

Large oversized water-to-water refrigerant heat exchangers and scroll compressors provide extremely efficient operation. The Aurora Controls extend this innovation and performance.

Operating Efficiencies

- Environmentally friendly R-410A refrigerant reduces ozone depletion.
- An optional hot water generator is available on O40, O50, O60, and O75 to generate hot water at considerable savings while improving overall system efficiency.
- High-stability bidirectional expansion valve provides superior performance.
- Efficient scroll compressors operate quietly.
- Oversized coaxial tube water-to-refrigerant heat exchanger increases efficiency.

Standard Features

- Heavy gauge cabinet
- Quiet scroll compressors in all models
- All interior cabinet surfaces are insulated with ½ in. [12.7 mm] thick 1 ½ lb. [681 g] density, surface coated, acoustic type glass fiber insulation.
- Optional IntelliStart® to reduce starting current (208-230/60/1)
- Field switchable control box
- Ultra-compact cabinet
- Multi-density laminate lined compressor blanket designed to suppress low frequency noise.
- Discharge line mufflers to help quiet compressor discharge gas pulsations.

Product Quality

- Heavy-gauge steel cabinets are finished with a durable polyester powder coat paint for long lasting beauty and service.
- All refrigerant brazing is performed in a nitrogen atmosphere.
- The O18H and O25H are available with load side copper vented double wall coaxial heat exchangers.
- Coaxial heat exchangers, refrigerant suction lines, hot water generator, and all water pipes are fully insulated to reduce condensation problems in low temperature operation.
- Computer controlled deep vacuum and refrigerant charging system.
- All joints are leak detected for maximum leak rate of less than ¼ oz. per year.
- Computer bar code equipped assembly line ensures all components are correct.
- All units are computer run-tested with water to verify both function and performance.
- Safety features include high- and low-pressure refrigerant controls to protect the compressor; hot water high-limit hot water generator pump shutdown.

Easy Maintenance and Service Advantages

- Removable compressor access panels.
- Quick attach wiring harnesses are used throughout for fast servicing.
- High and low pressure refrigerant service ports.

Options and Accessories

- Optional hot water generator with externally mounted pump (230/60/1) and water heater plumbing connector.
- Closed loop, source side, circulating pump kit
- Closed loop, load side, circulating pump kit
- Water connection kits
- Geo-Storage Tank (80-120 Gal.)
- IntelliStart
- HydroZone, tank control with outdoor reset
- HydroLogic
- HydroStat, communicating set point control

Application Flexibility

- Designed to operate with entering source temperature of 25°F and leaving load temperatures of 40°F to 130°F. See the capacity tables to see allowable operating conditions per model.
- Source side flow rates as low as 1.5 GPM/ton for well water, 50°F [10°C] min. EWT.
- Dedicated heating and heat pump models available.
- Dedicated non-reversible models are shipped as heating only; field convertible to cooling only.
- Modularized unit design and primary/secondary controls for optimum capacity matching and staging.
- Stackable for space conservation (to a maximum 3 units high).
- Compact size allows installation in confined spaces.
- Front or rear plumbing connections.
- Control Panel location is reversible.

Inside The Single Hydronic Series

Refrigerant

Our products all feature zero ozone depletion and low global warming potential R-410A refrigerant.

Cabinet

All units are constructed of corrosion resistant galvanized sheet metal with powder coat paint rated for more than 1000 hours of salt spray. Lift-out access panels provide access to the compressor section from two sides.

Compressors

High efficiency R-410A scroll compressors are used on every model. Scrolls provide both the highest efficiency available and great reliability.

Electrical Box

The control box is "field" movable from front to back for ease of application. Separate knockouts for low voltage, and two for power on, front and back, allow easy access to the control box. Large 75VA transformer assures adequate controls power for accessories.

Water Connections

Flush mount FPT water connection fittings allow one wrench leak-free connections and do not require a backup wrench. Factory installed water line thermistors can be viewed through the microprocessor interface tool.

Thermostatic Expansion Valve

All models utilize a balanced port bidirectional thermostatic expansion valve (TXV) for refrigerant metering. This allows precise refrigerant flow in a wide range of entering water variation (25 to 120°F [-7 to 49°C]) found in geothermal systems. The TXV is located in the compressor compartment for easy access.



Water-to-Refrigerant Heat Exchanger Coil

Large oversized coaxial refrigerant-to-water heat exchangers provide unparalleled efficiency. The coaxes are designed for low pressure drop and low flow rates. All coaxes are pressure rated to 450 psi water side and 600 psi on the refrigerant side. Refrigerant-to-water heat exchangers will be coated with ThermaShield to prevent condensation in low temperature loop operation. Vented, double walled heat exchanger suitable for potable water systems are standard on 018-025 heating only models.



Service Connections and Serviceability

Two Schrader service ports are provided for each unit. The suction side and discharge side ports are for field charging and servicing access. All valves are 7/16 in. SAE connections.



4-Way Reversing Valve

Units feature a reliable all-brass pilot operated refrigerant reversing valve. The reversing valve operation is limited to change of mode by the control to enhance reliability.



IntelliStart

The optional IntelliStart single phase soft starter will reduce the normal start current (LRA) by 60-70%. This allows the heat pump to go off-grid. Using IntelliStart also provides a substantial reduction in light flicker, reduces start-up noise, and improves the compressor's start behavior. IntelliStart is available in a field retrofit kit or as a factory installed option. IntelliStart is available on 208-230/60/1 voltage.



Water Quality

General

Water-to-water heat pumps may be successfully applied in a wide range of residential and light commercial applications. It is the responsibility of the system designer and installing contractor to ensure that acceptable water quality is present and that all applicable codes have been met in these installations. Failure to adhere to the guidelines in the water quality table could result in loss of warranty.

The heat exchangers and water lines in the units are copper or cupronickel tube. There may be other materials in the building's piping system that the designer may need to take into consideration when deciding the parameters of the water quality.

Application

These heat pumps are not intended for direct coupling to swimming pools and spas. If used for this type of application, a secondary heat exchanger must be used. Failure to supply a secondary heat exchanger for this application will result in warranty exclusion for primary heat exchanger corrosion or failure.

If an antifreeze or water treatment solution is to be used, the designer should confirm it does not have a detrimental effect on the materials in the system.

Contaminated Water

In applications where the water quality cannot be held to prescribed limits, the use of a secondary or intermediate heat exchanger is recommended to separate the unit from the contaminated water.

Water Treatment

Do not use untreated or improperly treated water. Equipment damage may occur. The use of improperly treated or untreated water in this equipment may result in scaling, erosion, corrosion, algae or slime. The services of a qualified water treatment specialist should be engaged to determine what treatment, if any, is required. The product warranty specifically excludes liability for corrosion, erosion or deterioration of equipment.

The following table outlines the water quality guidelines for unit heat exchangers. If these conditions are exceeded, a secondary heat exchanger is required. Failure to supply a secondary heat exchanger where needed will result in a warranty exclusion for primary heat exchanger corrosion or failure.



WARNING: Must have intermediate heat exchanger when used in pool and spa applications.

Water Quality Guidelines

Material		Copper	90/10 Cupronickel	316 Stainless Steel
pH	Acidity/Alkalinity	7 - 9	7 - 9	7 - 9
Scaling	Calcium and Magnesium Carbonate	(Total Hardness) less than 350 ppm	(Total Hardness) less than 350 ppm	(Total Hardness) less than 350 ppm
Corrosion	Hydrogen Sulfide	Less than 0.5 ppm (rotten egg smell appears at 0.5 ppm)	10 - 50 ppm	Less than 1 ppm
	Sulfates	Less than 125 ppm	Less than 125 ppm	Less than 200 ppm
	Chlorine	Less than 0.5 ppm	Less than 0.5 ppm	Less than 0.5 ppm
	Chlorides	Less than 20 ppm	Less than 125 ppm	Less than 300 ppm
	Carbon Dioxide	Less than 50 ppm	10 - 50 ppm	10 - 50 ppm
	Ammonia	Less than 2 ppm	Less than 2 ppm	Less than 20 ppm
	Ammonia Chloride	Less than 0.5 ppm	Less than 0.5 ppm	Less than 0.5 ppm
	Ammonia Nitrate	Less than 0.5 ppm	Less than 0.5 ppm	Less than 0.5 ppm
	Ammonia Hydroxide	Less than 0.5 ppm	Less than 0.5 ppm	Less than 0.5 ppm
	Ammonia Sulfate	Less than 0.5 ppm	Less than 0.5 ppm	Less than 0.5 ppm
Total Dissolved Solids (TDS)	Less than 1000 ppm	1000 - 1500 ppm	1000 - 1500 ppm	
LSI Index	+0.5 to -0.5	+0.5 to -0.5	+0.5 to -0.5	
Iron Fouling (Biological Growth)	Iron, FE ²⁺ (Ferrous) Bacterial Iron Potential	< 0.2 ppm	< 0.2 ppm	< 0.2 ppm
	Iron Oxide	Less than 1 ppm, above this level deposition will occur	Less than 1 ppm, above this level deposition will occur	Less than 1 ppm, above this level deposition will occur
Erosion	Suspended Solids	Less than 10 ppm and filtered for max. of 600 micron size	Less than 10 ppm and filtered for max. of 600 micron size	Less than 10 ppm and filtered for max. of 600 micron size
	Threshold Velocity (Fresh Water)	< 6 ft/sec	< 6 ft/sec	< 6 ft/sec

NOTES: Grains = ppm divided by 17
mg/L is equivalent to ppm

2/22/12

The Aurora Base Control System

Aurora 'Base' Control

The Aurora 'Base' Control (ABC) System is a complete residential and commercial comfort system that brings all aspects of the HVAC system into one cohesive module network. The ABC features microprocessor control and HP, LP, condensate and freeze detection, over/under voltage faults, along with communicating thermostat capability for complete fault detection text at the thermostat.

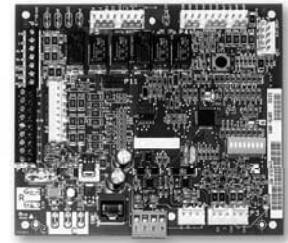

Aurora uses the Modbus communication protocol to communicate between modules. Each module contains the logic to control all features that are connected to the module. The Aurora 'Base' Control (ABC) has two Modbus channels. The first channel is configured as a master for connecting to devices such as a communicating thermostat, expansion board, or other slave devices. The second channel is configured as a slave for connecting the Aurora Interface Diagnostics Tool (AID Tool).

Aurora Control Features	Description	Aurora 'Base'
Microprocessor Compressor Control	Microprocessor control of compressor for timings with FPI, HP, LP, Condensate, assignable Acc relay	•
Base Hot Water Generator Operation	Compressor Contactor powers Hot Water Generator Pump with inline circuit breaker and thermostat limit.	•
Base Loop Pump Control	Compressor Contactor powers Loop Pump with inline circuit breaker and no loop pump linking capability.	•

Service Device	Description	Aurora 'Base'
 <p>Aurora Interface and Diagnostics (AID) Tool</p>	<p>Allows setup, monitoring and troubleshooting of any Aurora Control.</p> <p>NOTE: Although the ABC has basic compatibility with all Aurora, new product features may not be available on older AID Tools. To simplify the basic compatibility ensure the version of AID is at least the same or greater than the ABC software version.</p>	<p>For Service (Ver. 1.xx or greater)</p>

Add On Thermostats and Zoning	Description	Aurora 'Base'
HydroStat	Communicating controller for one hydronic heat pump.	Optional
HZO	Non-communicating controller for up to four heat pumps.	Optional
HZC	Non-communicating controller for one hydronic heat pump	Optional

The Aurora Base Control System cont.

Aurora ‘Base’ Control

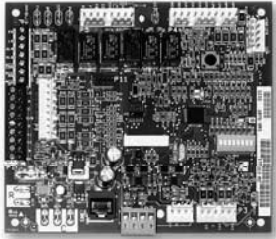

NOTE: Refer to the Aurora Base Control Application and Troubleshooting Guide and the Instruction Guide: Aurora Interface and Diagnostics (AID) Tool for additional information.

Control Features

- Random start at power up
- Anti-short cycle protection
- High and low pressure cutouts
- Loss of charge
- Water coil freeze detection
- Over/under voltage protection
- Load shed
- Emergency shutdown
- Diagnostic LED
- Test mode push button switch
- Alarm output
- Accessory output with N.O. and N.C.
- Modbus communication (master)
- Modbus communication (slave)

Field Selectable Options via Hardware

DIP Switch (SW1) – Test/Configuration Button (See SW1 Operation Table)

Test Mode

The control is placed in the test mode by holding the push button switch SW1 for 2 - 5 seconds. In test mode most of the control timings will be shortened by a factor of sixteen (16). LED3 (green) will flash at 1 second on and 1 second off. Additionally, when entering test mode LED1 (red) will flash the last lockout one time. Test mode will automatically time out after 30 minutes. Test mode can be exited by pressing and holding the SW1 button for 2 to 5 seconds or by cycling the power. **NOTE:** Test mode will automatically be exited after 30 minutes.

Reset Configuration Mode

The control is placed in reset configuration mode by holding the push button switch SW1 for 50 to 60 seconds. This will reset all configuration settings and the EEPROM back to the factory default settings. LED3 (green) will turn off when entering reset configuration mode. Once LED3 (green) turns off, release SW1 and the control will reset.

DIP Switch (SW2)

SW2-1 (Source) FP1 Selection – Low water coil temperature limit setting for freeze detection. On = 30°F; Off = 15°F.

SW2-2 (Load) FP2 Selection – On = 30°F; Off = 15°F

SW2-3 RV – O/B - thermostat type. Heat pump thermostats with “O” output in cooling or “B” output in Heating can be selected. On = O; Off = B.

SW2-4 Access Relay Operation (P2)
and 2-5

Access Relay Operation	SW2-4	SW2-5
Cycle with Blower	n/a	
Cycle with Compressor	OFF	OFF
Water Valve Slow Opening	ON	OFF
Cycle with Comm. T-stat Hum Cmd	n/a	

Cycle with Blower - (Not used on water-to-water)

Cycle with Compressor - The accessory relay will cycle with the compressor output.

Water Valve Slow Opening - The accessory relay will cycle and delay both the blower and compressor output for 90 seconds.

SW2-6 CC Operation – selection of single or dual capacity compressor. On = Single Stage; Off = Dual Capacity

SW2-7 Lockout and Alarm Outputs (P2) – selection of a continuous or pulsed output for both the LO and ALM Outputs. On = Continuous; Off = Pulsed

SW2-8 *Future Use*

Alarm Jumper Clip Selection

From the factory, ALM is connected to 24 VAC via JW2. By cutting JW2, ALM becomes a dry contact connected to ALG.

Field Selectable Options via Software

(Selectable via the Aurora AID Tool)

Safety Features

The following safety features are provided to protect the compressor, heat exchangers, wiring and other components from damage caused by operation outside of design conditions.

Fuse – a 3 amp automotive type plug-in fuse provides protection against short circuit or overload conditions.

Anti-Short Cycle Protection – 4 minute anti-short cycle protection for the compressor.

Random Start – 5 to 80 second random start upon power up.

The Aurora Base Control System cont.

Fault Retry - in the fault condition, the control will stage off the outputs and then “try again” to satisfy the thermostat Y input call. Once the thermostat input calls are satisfied, the control will continue on as if no fault occurred. If 3 consecutive faults occur without satisfying the thermostat Y input call, then the control will go to Lockout mode.

Lockout - The Alarm output (ALM) and Lockout output (L) will be turned on. The fault type identification display LED1 (Red) shall flash the fault code. To reset lockout conditions with SW2-8 On, thermostat inputs “Y1”, “Y2”, and “W” must be removed for at least 3 seconds. To reset lockout conditions with SW2-8 Off, thermostat inputs “Y1”, “Y2”, “W”, and “DH” must be removed for at least 3 seconds. Lockout may also be reset by turning power off for at least 30 seconds or by enabling the emergency shutdown input for at least 3 seconds.

High Pressure - fault is recognized when the Normally Closed High Pressure Switch, P4-9/10 opens, no matter how momentarily. The High Pressure Switch is electrically in series with the Compressor Contactor and serves as a hard-wired limit switch if an overpressure condition should occur.

Low Pressure - fault is recognized when the Normally Closed Low Pressure Switch, P4-7/8 is continuously open for 30 seconds. Closure of the LPS any time during the 30 second recognition time restarts the 30 second continuous open requirement. A continuously open LPS shall not be recognized during the 2 minute startup bypass time.

Loss of Charge - fault is recognized when the Normally Closed Low Pressure Switch, P4-7/8 is open prior to the compressor starting.

Freeze Detection (Source Coax) - set points shall be either 30°F or 15°F. When the thermistor temperature drops below the selected set point, the control shall begin counting down the 30 seconds delay. If the thermistor value rises above the selected set point, then the count should reset. The resistance value must remain below the selected set point for the entire length of the appropriate delay to be recognized as a fault. This fault will be ignored for the initial 2 minutes of the compressor run time.

Freeze Detection (Load Coax) - uses the FP2 input to protect against ice formation on the coax. The FP2 input will operate exactly like FP1.

Over/Under Voltage Shutdown - An over/under voltage condition exists when the control voltage is outside the range of 18 VAC to 30 VAC. If the over/under voltage shutdown lasts for 15 minutes, the lockout and alarm relay will be energized. Over/under voltage shutdown is self-resetting in that if the voltage comes back within range of 18 VAC to 30 VAC for at least 0.5 seconds, then normal operation is restored.

Operation Description

Power Up - The unit will not operate until all the inputs and safety controls are checked for normal conditions. The unit has a 5 to 80 second random start delay at power up. Then the compressor has a 4 minute anti-short cycle delay after the random start delay.

Standby In standby mode, Y1, Y2, W, DH, and G are not active. Input O may be active. The blower and compressor will be off.

Heating Operation

Heating, 1st Stage (Y1) - The compressor is energized 10 seconds after the Y1 input is received.

Cooling Operation

In all cooling operations, the reversing valve directly tracks the O input. Thus, anytime the O input is present, the reversing valve will be energized.

Cooling, 1st Stage (Y1, O) - The compressor is energized 10 seconds after the Y1 input is received.

Emergency Shutdown - Four (4) seconds after a valid ES input, P2-7 is present, all control outputs will be turned off and remain off until the emergency shutdown input is no longer present. The first time that the compressor is started after the control exits the emergency shutdown mode, there will be an anti-short cycle delay followed by a random start delay. Input must be tied to common to activate.

Load Shed - The LS input disables all outputs with the exception of the blower output. When the LS input has been cleared, the anti-short cycle timer and random start timer will be initiated. Input must be tied to common to activate.

The Aurora Base Control System cont.

Aurora 'Base' Control LED Displays

These three LEDs display the status, configuration, and fault codes for the control. These can also be read in plain English via the Aurora AID Tool.

Status LED (LED3, Green)

Description of Operation	Fault LED, Green
Normal Mode	ON
Control is Non-functional	OFF
Test Mode	Slow Flash
Lockout Active	Fast Flash
Dehumidification Mode	Flash Code 2
(Future Use)	Flash Code 3
(Future Use)	Flash Code 4
Load Shed	Flash Code 5
ESD	Flash Code 6
(Future Use)	Flash Code 7

Fault LED (LED1, Red)

Red Fault LED		LED Flash Code*	Lockout	Reset/Remove
ABC Basic Faults	Normal - No Faults	OFF	-	
	Fault - Input	1	No	Auto
	Fault - High Pressure	2	Yes	Hard or Soft
	Fault - Low Pressure	3	Yes	Hard or Soft
	Fault - Freeze Detection FP2	4	Yes	Hard or Soft
	Fault - Freeze Detection FP1	5	Yes	Hard or Soft
	Fault - Condensate Overflow	7	Yes	Hard or Soft
	Fault - Over/Under Voltage	8	No	Auto
	Fault - FP1 & FP2 Sensor Error	11	Yes	Hard or Soft

NOTE: All codes >11 use long flash for tens digit and short flash for the ones digit. 20, 30, 40, 50, etc. are skipped.

ABC Control Board Layout

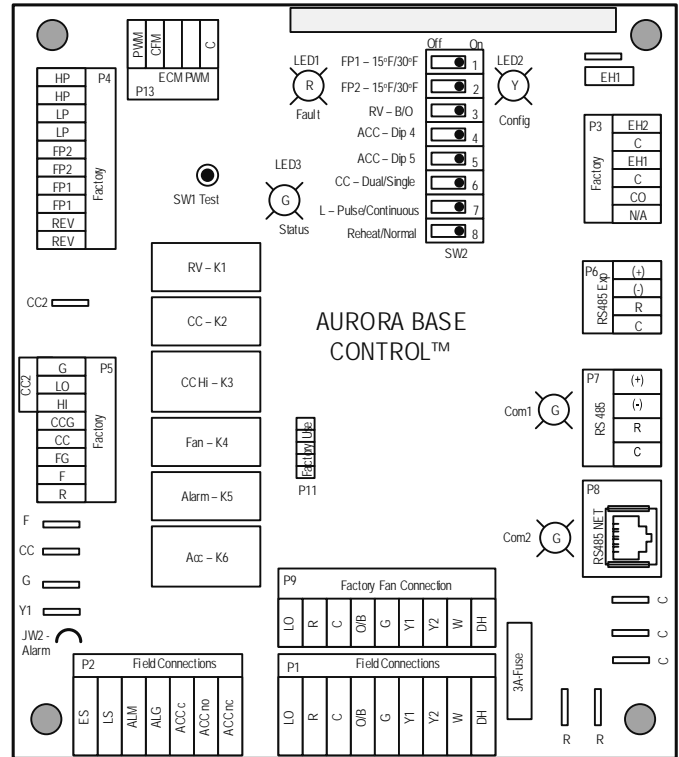

Aurora Interface and Diagnostics (AID) Tool

The Aurora Interface and Diagnostics (AID) Tool is a device that is a member of the Aurora network.

The AID Tool is used to troubleshoot equipment which uses the Aurora control via Modbus RTU communication. The AID Tool provides diagnostics, fault management, ECM setup, and system configuration capabilities to the Aurora family of controls. An AID Tool is recommended, although not required, for ECM airflow settings. The AID Tool simply plugs into the exterior of the cabinet in the AID Tool port.



Application Notes

The Closed Loop Heat Pump Concept

The basic principle of a water source heat pump is the transfer of heat into water from the space during cooling, or the transfer of heat from water into the space during heating. Extremely high levels of energy efficiency are achieved as electricity is used only to move heat, not to produce it. Using our typical water-to-water heat pump one unit of electricity will move four to five units of heat.

When multiple water source heat pumps are combined on a common circulating loop, the ultimate in energy efficiency is created: The water-to-water units on cooling mode are adding heat to the loop which the units in heating mode can absorb, thus removing heat from the area where cooling is needed, recovering and redistributing that heat for possible utilization elsewhere in the system. In modern commercial structures, this characteristic of heat recovery from core area heat generated by lighting, office equipment, computers, solar radiation, people or other sources, is an important factor in the high efficiency and low operating costs of our closed source heat pump systems.

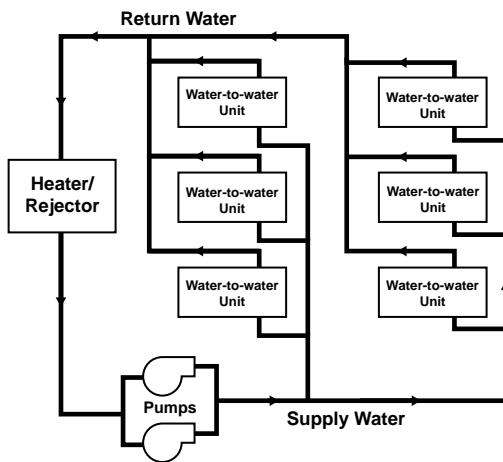

In the event that a building's net heating and cooling requirements create loop temperature extremes, our units have the extended range capacity and versatility to maintain a comfortable environment for all building areas. Excess heat can be stored for later utilization or be added or removed in one of three ways; by ground-source heat exchanger loops: plate heat exchangers connected to other water sources, or conventional cooler/boiler configurations. Your sales representative has the expertise and computer software to assist in determining optimum system type for specific applications.

The Closed Loop Advantage

A properly applied water source heat pump system offers many advantages over other systems. First costs are

low because units can be added to the loop on an "as needed basis"- perfect for speculative buildings. Installed costs are low since units are self-contained and can be located adjacent to the occupied space, requiring minimal ductwork. Maintenance can be done on individual units without system shut-down. Conditions remain comfortable since each unit operates separately, allowing cooling in one area and heating in another. Tenant spaces can be finished and added as needed. Power billing to tenants is also convenient since each unit can be individually metered: each pays for what each uses. Nighttime and/or weekend uses of certain areas are possible without heating or cooling the entire facility. A decentralized system also means if one unit should fault, the rest of the system will continue to operate normally, as well as eliminating air cross-contamination problems and expensive high pressure duct systems requiring an inefficient electric resistance reheat mode.

The Best Approach

There are a number of proven choices in the type of system which would be best for any given application. Most often considered are:

Vertical - Closed Loop/Ground Source

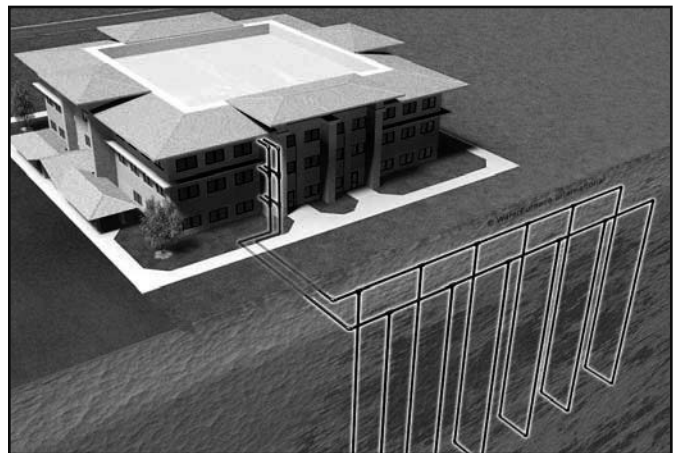

• **Closed Loop/Ground-Source Systems** utilize the stable temperatures of the earth to maintain proper water source temperatures (via vertical or horizontal closed loop heat exchangers) for our extended range heat pump system. Sizes range from a single unit through many hundreds of units. When net cooling requirements cause closed loop water temperatures to rise, heat is dissipated into the cooler earth through buried high strength plastic pipe "heat exchangers." Conversely if net space heating demands cause loop heat absorption beyond that heat recovered from building core areas, the loop temperature will fall causing heat to be extracted from the earth. Due to the extended loop temperatures, AHRI/ISO 13256-1 Ground Loop Heat Pumps are required for this application.

Application Notes cont.

Because auxiliary equipment such as a fossil fuel boiler and cooling tower are not required to maintain the loop temperature, operating and maintenance costs are very low. Ground-source systems are most applicable in residential and light commercial buildings where both heating and cooling are desired, and on larger envelope dominated structures where core heat recovery will not meet overall heating loads. Both vertical and horizontally installed closed-loops can be used. The land space required for the "heat exchangers" is 100-250 sq. ft./ton on vertical (drilled) installations and 750-1500 sq. ft./ton for horizontal (trenched) installations. Closed loop heat exchangers can be located under parking areas or even under the building itself.

On large multi-unit systems, sizing the closed loop heat exchanger to meet only the net heating loads and assisting in the summer with a closed circuit cooling tower may be the most cost effective choice.

Surface Water - Closed Loop/Ground Source

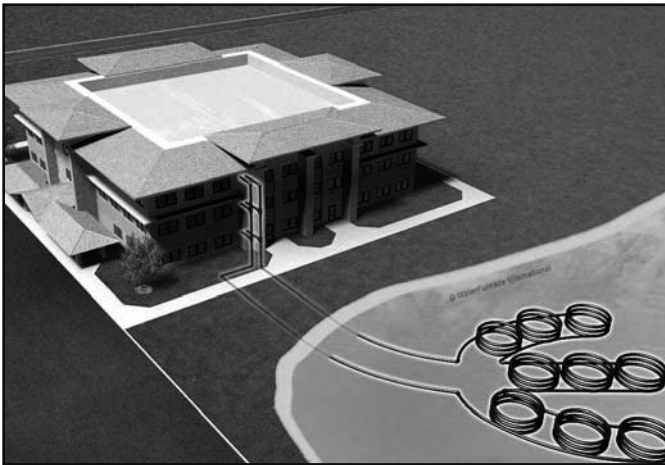

• ***Closed Loop/Ground-Source Surface Water Systems*** also utilize the stable temperatures of Surface Water to maintain proper water source temperatures for our extended range heat pump systems. These systems have all of the advantages of horizontal and vertical closed loop systems. Due to the extended loop temperatures, AHRI/ISO 13256-1 Ground Water or Ground Loop Heat Pumps are required for this application.

In cooling dominated structures, the ground-source surface water systems can be very cost effective especially where local building codes require water retention ponds for short term storage of surface run-off. Sizing requirements for the surface water is a minimum of 500 sq. ft./ton of surface area at a minimum depth of 8 feet. Your sales representative should be contacted when designs for heating dominated structures are required.

Plate Heat Exchanger - Closed Loop/Ground Water



• ***Closed Loop/Ground Water Plate Heat Exchanger Systems*** utilize lake, ocean, well water or other water sources to maintain closed loop water temperatures in multi-unit systems. A plate frame heat exchanger isolates the units from any contaminating effects of the water source, and allows periodic cleaning of the heat exchanger during off peak hours.

Operation and benefits are similar to those for ground-source systems. Due to the extended loop temperatures, AHRI/ISO 13256-1 Ground Loop Heat Pumps are required for this application. Closed loop plate heat exchanger systems are applicable in commercial, marine, or industrial structures where the many benefits of a water source heat pump system are desired, regardless of whether the load is heating or cooling dominated.

Application Notes cont.

Cooler/Boiler - Closed Loop



• **Closed Loop /Cooler-Boiler Systems** utilize a closed heat recovering loop with multiple water source heat pumps in the more conventional manner. Typically a boiler is employed to maintain closed loop temperatures above 60°F and a cooling tower to maintain loop temperatures below 90°F. These systems are applicable in medium to large buildings regardless of whether the load is heating or cooling dominated. Due to the moderate loop temperatures, AHRI/ISO 13256-1 Water Loop Heat Pumps are required for this application.

Typical Application Piping

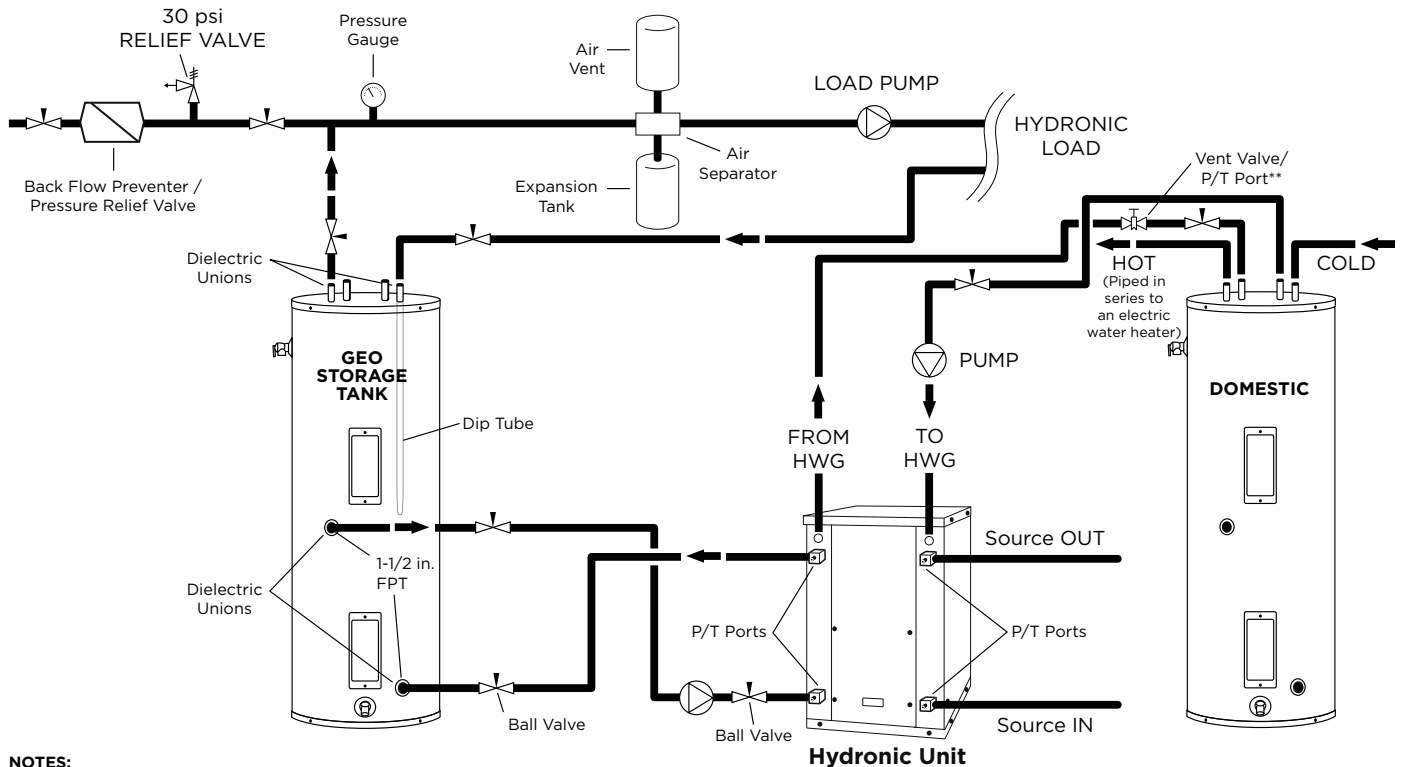

NOTES:

- * A 30 psi pressure relief valve (Part No: SRV30) should be used in hydronic applications.
- ** Vent valve or P/T port at highest point in return line prior to ball valve.

Application Notes cont.

Heating with hot water is versatile because there are many ways of distributing the heat through the building. The options range from heavy cast iron radiators seen in older buildings to modern, baseboard-style convection radiation, and from invisible radiant floor heating to forced air systems using fan coil units.

A boiler is often used to make domestic hot water and to heat swimming pools or hot tubs.

The various distribution systems have all been used successfully with a geothermal heat pump system. When designing or retrofitting an existing hydronic heating system, however, the water temperature produced by the heat pump is a major consideration.

In general, heat pumps are not designed to produce water above 130°F. The efficiency decreases as the temperature difference (ΔT) between the heat load (generally the earth loop) and the supply water (to the distribution system) increases. Figure 1 illustrates the effect of source and load temperatures on the system. The heating capacity of the heat pump also decreases as the temperature difference increases.

When using the various types of hydronic heat distribution systems, the temperature limits of the geothermal system must be considered. In new construction, the distribution system can easily be designed with the temperature limits in mind. In retrofits, care must be taken to address the operating temperature limits of the existing distribution system.

Figure 1: As the ΔT increases, the Coefficient of Performance (COP) decreases. When the system produces 130°F water from a 30°F earth loop, the ΔT is 100°F, and the COP is approximately 2.5. If the system is producing water at 90°F, the ΔT is 60°F and the COP rises to about 3.8, an increase of over 50%.

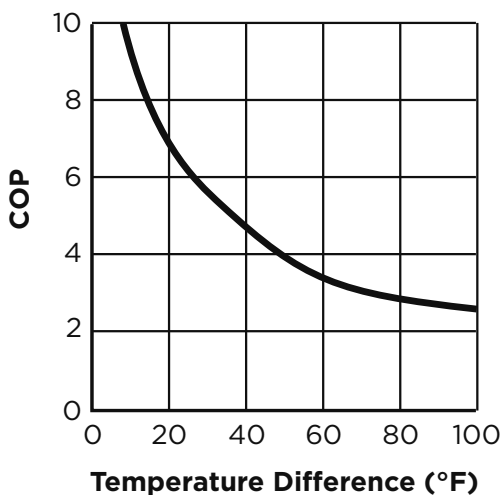

Baseboard Radiation

In existing systems, baseboard radiation is typically designed to operate with 160° to 240°F water or steam. Baseboard units are typically copper pipe with aluminum fins along the length of the pipe, as shown in Figure 2. A decorative cover is normally fitted over the fin tube.

The operation of a baseboard radiation system depends on setting up a convection current in the room: air is warmed by the fin tube, rises and is displaced by cool air.

The heating capacity of a baseboard system is a factor of the area of copper tube and fins exposed to the air and the temperature difference between the air and the fin tube. The velocity and volume of water flowing through the baseboard affects the temperature of the copper and fins. Baseboard units are normally rated in heat output/length of baseboard at a standard water temperature and flow. Manufacturers can provide charts which will give the capacities at temperatures and flows below the standard. Figure 3 shows approximate heating capacities for fin tube radiation using water from 100° to 130°F water.

Baseboards are available using two or three fin tubes tiered above one another in the same cabinet. With the additional surface area, the air can be heated enough to set up a convection current with water temperatures as low as 110° to 130°F (see Figure 3).

It is important to ensure that the heat output of the system is adequate to meet the heat loss of the room or building at the temperatures the geothermal system is capable of producing.

Baseboard radiation is limited to space heating. Cooling is typically provided by a separate, forced air distribution system.

Figure 2: Baseboard radiators are typically constructed of copper tube with closely spaced aluminum fins attached to provide more surface area to dissipate heat. Some of the factors affecting the amount of heat given off by fin tube radiators are the water temperature, water velocity, air temperature, and fin spacing and size.

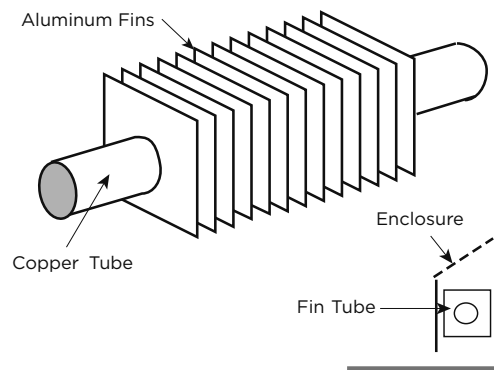

Application Notes cont.

The heating capacity (Btuh/linear foot) of baseboard radiators drop as the water temperature is reduced. The heating capacity of most baseboard radiators is rated using 200°F water, 65°F air temperature. Listed in Figure 3 is the range of heating capacities of baseboard radiators at the standard temperatures and the range of capacities when the temperatures are reduced to the operating range of a heat pump system. Some of the factors that effect the capacity of a radiator are:

- Size of the fins - range from 2.75 in. x 3 in. to 4 in. x 4 in.
- Fin spacing - 24 to 48 foot
- Diameter of copper tube - range from .75 in. to 2 in.
- Fin material - aluminum or steel
- Configuration and height of the enclosure
- Height unit is mounted from the floor
- Water flow through the radiator

Generally, the smaller fins with fewer fins/foot will have lower heating capacity. Larger copper tube diameter and aluminum fins will have a higher capacity. Higher water flow will increase capacity. Adding a second fin tube to the same enclosure will increase the capacity by 50 to 60%. Adding two fin tubes will increase the capacity by 75 to 80%.

Figure 3: Heating output per linear foot

Average Water Temp.	Entering Air Temperatures		
	55°F	65°F	70°F
110°F	190-380	160-320	150-300
120°F	240-480	205-410	195-390
130°F	295-590	265-532	245-490

Cast Iron Radiation

Retrofit applications for hydronic/geothermal heat pump systems are often required to work with existing cast iron radiators or their replacements (see Figure 4). Typically, cast iron radiator systems operate with water temperatures of 125° to 160°F.

These temperatures are higher than geothermal water-to-water heat pumps are capable of providing. Cast iron radiators can work with geothermal systems, provided the heat output of the radiators will meet the maximum heat loss of the building at the lower temperatures.

If the insulation of the building has been upgraded since the original installation, it is possible that the lower temperatures will be able to meet the reduced heat loss of the building.

Figure 4: Baseboard System

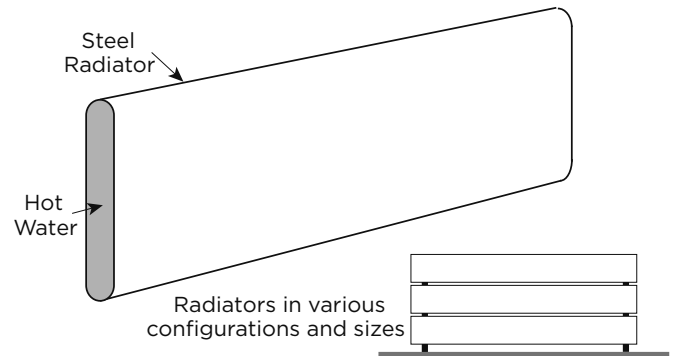

Radiant Floor Heating

Radiant floor heating has been the system of choice in many parts of Europe for some time. Manufacturers have developed tubing designed for installation in concrete floors and raised wood floors.

Floor heating systems have several benefits in residential, commercial and industrial heating applications. In a building with a radiant floor heating system, the entire floor acts as a heat source for the room. People feel comfortable with lower air source temperatures if their feet are warm. Typically the space will feel comfortable with air temperatures as low as 65°F. Since the heat loss of a building is directly related to the temperature difference (ΔT) between the inside and outside, a lower ΔT means the heat loss is lower.

Air temperatures in a room with a forced air heating system tend to be warmer nearer to the ceiling than the floor (see Figure 5). The hot air rises and creates a greater pressure imbalance between the inside and outside. The infiltration increases, resulting in a higher heat loss. Air temperatures in a room with radiant floor heating tend to be warmer at the floor than the ceiling, helping to cut down on infiltration in the building. The energy savings in a building with radiant floor heating can range from 10 to 20%.

Figure 5: Temperature Comparison

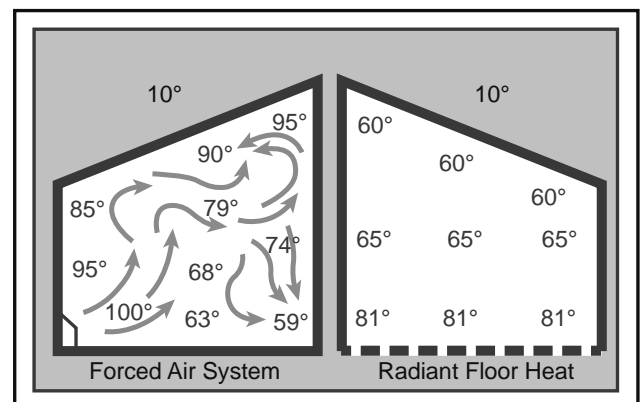

Application Notes cont.

A floor heat system can be designed to heat a building with water temperatures as low as 90°F.

Figure 1 shows how a geothermal system operates more efficiently with a lower ΔT between the source and the load. With only a 60°F temperature difference, a geothermal heat pump will operate at COPs over 4, about 20% higher than a forced air geothermal system in the same installation.

Some of the factors affecting the heating capacity of a floor heating system are as follows:

- The type of finish flooring
- The spacing of the pipe
- The water flow through the pipe
- The temperature of the supply water
- The floor material (wood, concrete or poured Gypcrete™)
- Insulation value under the floor
- The piping layout

The spacing of the pipe in residential applications can vary from 4 in. to 12 in. If the spacing is too large, the temperature of the floor can vary noticeably. In industrial applications, variation in the floor temperature is not as important, and the spacing is related directly to the heat output required.

Radiant floor heating systems work well with geothermal heat pump systems. For efficient operation, the system must be designed with the lowest possible water temperatures.

There are some drawbacks with a radiant floor heating system. Air conditioning is only possible by adding a second system using forced air. This can add substantial cost to an installation where air conditioning is also needed. A separate air handling system is needed to clean the air or to introduce fresh air.

Industrial buildings, especially those with high ceilings and large overhead doors, have an advantage with a radiant floor heating system. Heat is stored in the concrete floor, and when a door is opened, the stored heat is immediately released to the space. The larger the ΔT between the air in the space and the floor, the quicker the floor releases its heat to the space.

Maintenance garages benefit from radiant floor heating systems. Cold vehicles brought into the garage are warmed from underneath. The snow melts off the vehicle and dries much more quickly than when heated from above.

Some pipe manufacturers include an oxygen diffusion barrier in the pipe to prevent oxygen diffusion through the pipe. Good system design and careful installation, however, will eliminate virtually all of the problems encountered with air in the system. Like earth loop design, it is important to design the system to facilitate flushing the air initially and ensuring that the flows can be balanced properly.

Fan Coil Units and Air Handlers

Fan coil units, air handlers, force flow units, etc. are all basically a hot water radiator or coil (usually copper piping with aluminum fins) with a fan or blower to move the air over the coil (see Figure 6). The term “fan coil units” typically applies to smaller units that are installed in the zone or area in which heating (or cooling) is needed. They are available in many different configurations, sizes and capacities. Fan coil units are designed to be connected to a ductwork system and can be used to replace a forced air furnace. Other units are designed for use without ductwork and are mounted in a suspended ceiling space with only a grill showing in place of a ceiling tile. Some can be mounted on a wall under a window, projecting 8 in. to 10 in. into the room or even flush to the wall surface, mounted between wall studs. Some are available with or without finished, decorative cabinets. For industrial applications, inexpensive “unit heaters” are available, with only a coil and an axial fan. Fan coil units and unit heaters are normally available with air handling capacities of 200 to 2,000 cfm.

The term “air handler” normally applies to larger units, mounted in mechanical rooms, mechanical crawl spaces or rooftops. They typically have an air handling capacity of over 2,000 cfm and are available for capacities of up to 50,000 cfm. Air handlers are typically built for a specific installation and are available with many different types of heating and cooling coils. They can include additional coils for heating make-up air, dehumidification and exhaust air heat recovery.

Fan coils and air handlers typically have one or two coils and a blower. Air is heated by hot water circulated through the hot water coil. Chilled water is circulated through the coil if air conditioning is needed. Blowers can be provided to fit various applications, with or without duct-work. Unit heaters typically use axial fans in applications where ductwork is not needed.

Fan coil units and air handlers are used in many different applications. They have been used to heat buildings using water temperatures as low as 90° to 100°F. New systems can be designed to operate very efficiently with a geothermal system.

Application Notes cont.

Figure 6: Fan Coils

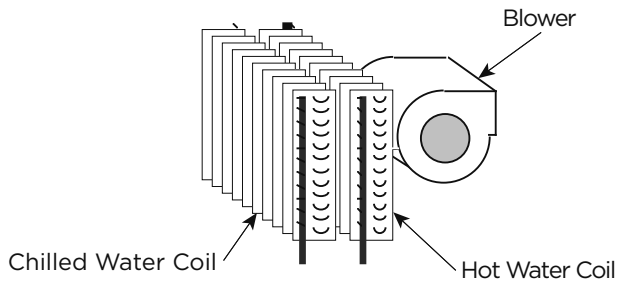

Cooling with a Hydronic System

Cooling a building with an existing radiant hydronic heating system can be a challenge. If baseboard, cast iron radiators or a radiant floor heating system is cooled lower than the dew point, condensation will form on the floor or drip off the radiators.

There is generally minimal or no ductwork for ventilation in existing buildings with radiant hydronic heat. Typically, cooling is provided with separate units where it is needed. This is often done using through-the-wall or window air conditioners, ductless split air conditioning units, or rooftop units.

A water-to-water heat pump system can provide water to ducted or unducted fan coil units. The system can provide chilled water to cool the building, as well as hot water for the heating system when needed.

A limited amount of cooling can be done by circulating chilled water through the piping in the floor. This can be effective in buildings with high solar loads or lighting loads, where much of the heat gain is radiant heat being absorbed by the floor. Cooling fresh air used for ventilation as it is brought into the building, using a chilled water coil, can sometimes provide the additional cooling needed. Care must be taken to avoid cooling the floor below the dew point because condensation may form on the floor.

Buildings with fan coil units and air handlers can generally be easily retrofitted for cooling. Often it is simply a matter of adding a cooling coil to the existing air handlers and fan coil units. Water-to-water heat pumps can provide hot water for the heating coils as well as chilled water for the air conditioning.

Controls

The control of a mechanical system determines how it functions. For the building to work efficiently and comfortably, the building owner or manager must understand what the system is doing and how to control it.

As Figure 1 shows, the efficiency of a heat pump is a factor of the difference in temperature between the source and the load. The heat loss or heat gain of a building varies with the weather and the use of the building. As the outdoor temperature decreases, the heat loss of the building increases. When the ventilation system is started up, the heating or cooling loads increase. As the occupancy increases, lighting or the solar gain increases, and the cooling load increases. At times the building may require virtually no heating or cooling.

With hydronic heating and cooling distribution equipment, whether it is baseboard radiation, fan coil units or radiant floor heating, the output of the equipment is directly related to the temperature and velocity of the water flowing through it. Baseboard radiation puts out approximately 50% less heat with 110°F water than with 130°F water. The same is true with fan coil units and radiant floor heating.

If a system is designed to meet the maximum heat loss of a building with 130°F water, it follows that if the heat loss is 50% lower when the outdoor temperature is higher and the building has high internal gains because of lighting and occupancy, the lower heat loss can be met with 110°F water. This greatly increases the COP of the heat pumps.

The same control strategy is equally effective in cooling. During peak loads, water chilled to 40°F may be needed; at other times 55°F water will provide adequate cooling. Significant increases in the EER can be achieved. Latent loads must always be considered when using warmer water.

Dimensional Data

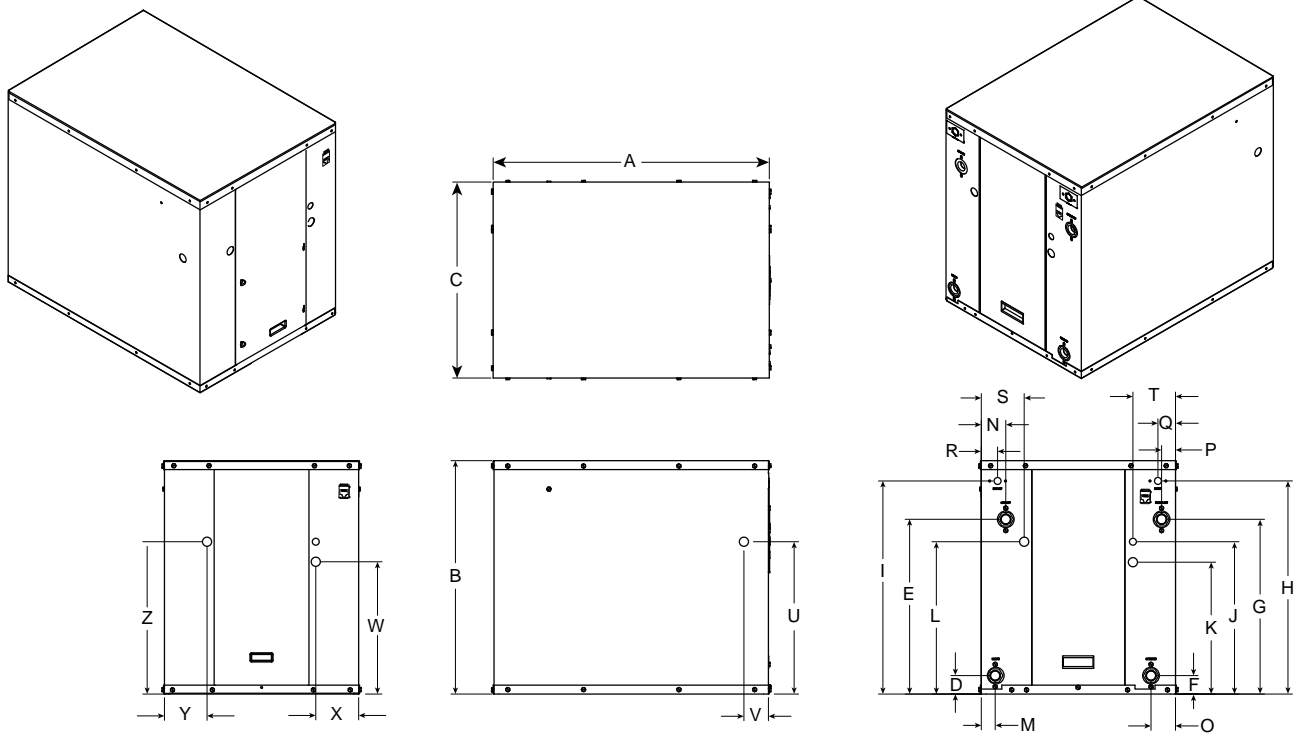

2/15/16

Model	Overall Cabinet			Water Connections									Electrical Knockouts			
	A	B	C	D	E	F	G	H	I				J	K	L	
	Depth	Height	Width	Load Liquid In	Load Liquid Out	Source Liquid In	Source Liquid Out	HWG In	HWG Out	Load Water FPT	Source Water FPT	HWG Water FPT	1/2 in. cond	3/4 in. cond	3/4 in. cond	
018	in.	23.5	26.1	19.5	10.0	22.2	10.0	22.2	-	-	1 in.	1 in.	-	16.0	14.2	14.2
	cm.	59.7	66.3	49.5	25.4	56.4	25.4	56.4	-	-	25.4 mm	25.4 mm	-	40.6	36.1	36.1
025	in.	23.5	26.1	19.5	10.0	22.2	10.0	22.2	-	-	1 in.	1 in.	-	16.0	14.2	14.2
	cm.	59.7	66.3	49.5	25.4	56.4	25.4	56.4	-	-	25.4 mm	25.4 mm	-	40.6	36.1	36.1
040	in.	31.0	26.2	22.0	2.1	19.6	2.1	19.6	23.9	23.9	1 in.	1 in.	1/2 in.	17.1	14.8	17.1
	cm.	78.7	66.5	55.9	5.3	49.8	5.3	49.8	60.7	60.7	25.4 mm	25.4 mm	12.7 mm	43.4	37.6	43.4
050	in.	31.0	26.2	22.0	2.2	20.6	2.2	20.6	23.9	23.9	1-1/4 in.	1-1/4 in.	1/2 in.	17.1	14.8	17.1
	cm.	78.7	66.5	55.9	5.6	52.3	5.6	52.3	60.7	60.7	31.8 mm	31.8 mm	12.7 mm	43.4	37.6	43.4
060 & 075	in.	31.0	26.2	22.0	2.4	23.0	2.4	23.0	20.6	20.6	1-1/4 in.	1-1/4 in.	1/2 in.	17.1	14.8	17.1
	cm.	78.7	66.5	55.9	6.1	58.4	6.1	58.4	52.3	52.3	31.8 mm	31.8 mm	12.7 mm	43.4	37.6	43.4

Model	Water Connections										Electrical Knockouts				
	M	N	O	P	Q	R	S	T	U	V	W	X	Y	Z	
	Load Liquid In	Load Liquid Out	Source Liquid In	Source Liquid Out	HWG In	HWG Out	Power Supply	Low Voltage	Side Power Supply	Side Power Supply	Ext Pump	Ext Pump	Power Supply	Power Supply	
018	in.	2.4	2.4	2.4	2.4	-	-	3.5	2.9	14.9	2.6	2.1	1.8	2.9	4.1
	cm.	6.1	6.1	6.1	6.1	-	-	8.9	7.4	37.8	6.6	5.3	4.4	7.4	10.4
025	in.	2.4	2.4	2.4	2.4	-	-	3.5	2.9	14.9	2.6	2.1	1.8	2.9	4.1
	cm.	6.1	6.1	6.1	6.1	-	-	8.9	7.4	37.8	6.6	5.3	4.4	7.4	10.4
040	in.	1.6	2.8	2.8	1.6	2.0	1.8	4.8	4.8	17.1	2.8	14.9	4.8	4.8	17.1
	cm.	4.1	7.0	7.0	4.1	5.1	4.6	12.2	12.2	43.4	7.0	37.8	12.2	12.2	43.4
050	in.	1.8	3.6	3.6	1.8	2.1	1.8	4.8	4.8	17.1	2.8	14.9	4.8	4.8	17.1
	cm.	4.6	9.1	9.1	4.6	5.3	4.6	12.2	12.2	43.4	7.1	37.8	12.2	12.2	43.4
060 & 075	in.	1.8	4.0	4.0	1.8	4.2	1.4	4.8	4.8	17.1	2.8	14.9	4.8	4.8	17.1
	cm.	4.6	10.2	10.2	4.6	10.7	3.6	12.2	12.2	43.4	7.1	37.8	12.2	12.2	43.4

8/6/10

Physical Data

Model	018	025	040	050	060	075
Compressor (1 each)	Scroll					
Factory Charge R410a, oz [kg]	44.0 [1.25]	58.0 [1.64]	70 [1.98]	68 [1.93]	104 [2.95]	110 [3.12]
Coax & Piping Water Volume - gal [l]*	.52 [1.97]	.89 [3.38]	1.0 [3.94]	1.4 [5.25]	1.6 [6.13]	1.6 [6.13]
Weight - Operating, lb [kg]	191 [86.6]	225 [102.1]	290 [131.5]	325 [147.4]	345 [156.5]	345 [156.5]
Weight - Packaged, lb [kg]	213 [96.6]	247 [112.0]	305 [138.3]	340 [154.2]	360 [163.3]	360 [163.3]

NOTE: * Source or load side only.

8/6/10

Electrical Data

Unit Model	Rated Voltage	Voltage Min/Max	Compressor			Load Pump	Source Pump	Total Unit FLA	Min Ckt Amp	Maximum Fuse/HACR
			RLA	LRA	LRA*					
018	208-230/60/1	187/253	9.0	48.0	17.0	1.8	5.4	16.2	18.5	25
025	208-230/60/1	187/253	14.1	73.0	21.4	1.8	5.4	21.3	24.8	35
	265/60/1	239/292	11.2	60.0	n/a	-	-	11.2	14.0	25
	460/60/3	414/506	4.2	28.0	16.8	-	-	4.2	5.3	6
040	208-230/60/1	187/253	20.0	115.0	40.3	1.8	5.4	27.2	32.2	50
	208-230/60/3	187/253	12.8	95.0	57.0	-	-	12.8	16.0	25
	460/60/3	414/506	6.4	45.0	27.0	-	-	6.4	8.0	10
	575/60/3	518/632	5.4	38.0	n/a	-	-	5.4	6.8	10
050	208-230/60/1	187/253	26.4	134.0	46.9	1.8	5.4	33.6	40.2	60
	265/60/1	239/292	19.9	130.0	n/a	-	-	19.9	24.9	40
	208-230/60/3	187/253	16.0	110.0	66.0	-	-	16.0	20.0	35
	460/60/3	414/506	7.8	52.0	31.2	-	-	7.8	9.8	15
	575/60/3	518/632	5.7	38.9	n/a	-	-	5.7	7.1	10
060	208-230/60/1	187/253	30.1	145.0	50.8	1.8	5.4	37.3	44.8	70
	208-230/60/3	187/253	17.3	120.0	72.0	-	-	17.3	21.6	35
	460/60/3	414/506	9.6	70.0	42.0	-	-	9.6	12.0	20
	575/60/3	518/632	8.0	53.0	n/a	-	-	8.0	10.0	15
075	208-230/60/1	187/253	26.9	145.0	50.8	1.8	5.4	34.1	40.8	60
	208-230/60/3	187/253	22.4	190.0	114.0	-	-	22.4	28.0	50
	460/60/3	414/506	12.2	87.0	52.2	-	-	12.2	15.3	25
	575/60/3	518/632	9.6	62.0	n/a	-	-	9.6	12.0	20

Notes: All fuses type "D" time delay (or HACR circuit breaker in USA).

Source pump amps shown are for up to a 1/2 HP pump

Load pump amps shown are for small circulators.

*LRA with IntelliStart installed.

1/15/2015

Antifreeze Correction

Catalog performance can be corrected for antifreeze use. Please use the following table and note the example given.

Antifreeze Type	Antifreeze % by wt	Heating		Cooling		Pressure Drop
		Load	Source	Load	Source	
EWT - °F [°C]		80 [26.7]	30 [-1.1]	50 [10.0]	90 [32.2]	30 [-1.1]
Water	0	1.000	1.000	1.000	1.000	1.000
Ethylene Glycol	10	0.990	0.973	0.976	0.991	1.075
	20	0.978	0.943	0.947	0.979	1.163
	30	0.964	0.917	0.921	0.965	1.225
	40	0.953	0.890	0.897	0.955	1.324
	50	0.942	0.865	0.872	0.943	1.419
Propylene Glycol	10	0.981	0.958	0.959	0.981	1.130
	20	0.967	0.913	0.921	0.969	1.270
	30	0.946	0.854	0.869	0.950	1.433
	40	0.932	0.813	0.834	0.937	1.614
	50	0.915	0.770	0.796	0.922	1.816
Ethanol	10	0.986	0.927	0.945	0.991	1.242
	20	0.967	0.887	0.906	0.972	1.343
	30	0.944	0.856	0.869	0.947	1.383
	40	0.926	0.815	0.830	0.930	1.523
	50	0.907	0.779	0.795	0.911	1.639
Methanol	10	0.985	0.957	0.962	0.986	1.127
	20	0.969	0.924	0.929	0.970	1.197
	30	0.950	0.895	0.897	0.951	1.235
	40	0.935	0.863	0.866	0.936	1.323
	50	0.919	0.833	0.836	0.920	1.399



WARNING: Gray area represents antifreeze concentrations greater than 35% by weight and should be avoided due to the extreme performance penalty they represent.

Antifreeze Correction Example

Antifreeze solution is propylene glycol 20% by weight for the source and methanol 10% for the load. Determine the corrected heating at 30°F source and 80°F load as well as pressure drop at 30°F for an 050. Also, determine the corrected cooling at 90°F source and 50°F load.

The corrected heating capacity at 30°F/80°F would be:

$$46,700 \text{ MBTUH} \times 0.913 \times 0.985 = 41,998 \text{ MBTUH}$$

The corrected cooling capacity at 90°F/50°F would be:

$$44,200 \times 0.969 \times 0.962 = 41,202 \text{ MBTUH}$$

The corrected pressure drop at 30°F and 15 GPM would be:

$$5.2 \text{ psi} \times 1.270 = 6.60 \text{ psi}$$

AHRI/ISO 13256-2 Performance Ratings

English (IP) Units

Model	Capacity Modulation	Flow Rate		Water Loop Heat Pump				Ground Water Heat Pump				
				Cooling 86°F Source 53.6°F Load		Heating 68°F Source 104°F Load		Cooling 59°F Source 53.6°F Load		Heating 50°F Source 104°F Load		Energy Star Compliant
		Load Gpm	Source Gpm	Capacity Btuh	EER Btuh/W	Capacity Btuh	COP	Capacity Btuh	EER Btuh/W	Capacity Btuh	COP	
018	Single	5	5	16,400	14.0	22,200	4.5	18,800	22.9	18,500	3.7	Yes
025	Single	7	7	23,700	13.6	32,800	4.6	26,700	21.2	27,100	3.8	Yes
040	Single	10	10	35,900	15.5	47,900	4.8	40,900	23.4	39,100	3.9	Yes
050	Single	15	15	49,800	13.9	65,000	4.4	55,600	21.6	54,200	3.7	Yes
060	Single	18	18	55,400	13.6	78,000	4.7	62,500	20.6	63,200	3.8	Yes
075	Single	19	19	66,000	12.3	93,100	4.2	74,100	18.0	77,100	3.5	No

Model	Capacity Modulation	Flow Rate		Ground Loop Heat Pump				
				Cooling 77°F Source 53.6°F Load		Heating 32°F Source 104°F Load		Energy Star Compliant
		Load Gpm	Source Gpm	Capacity Btuh	EER Btuh/W	Capacity Btuh	COP	
018	Single	5	5	17,300	16.6	14,700	3.1	Yes
025	Single	7	7	24,700	16.1	22,000	3.1	Yes
040	Single	10	10	37,700	17.5	30,500	3.1	Yes
050	Single	15	15	51,500	16.4	44,200	3.1	Yes
060	Single	18	18	58,000	16.1	50,100	3.1	Yes
075	Single	19	19	68,400	14.0	61,500	2.9	No

NOTE: All ratings based upon 208V operation.

01/03/12



Pressure Drop

Model	GPM	Pressure Drop (psi)				
		30°F	60°F	80°F	100°F	120°F
018R*	3.0	0.5	0.4	0.4	0.3	0.3
	4.0	1.1	0.9	0.9	0.8	0.8
	5.0	1.6	1.4	1.4	1.3	1.3
	6.0	2.1	1.9	1.9	1.8	1.8
025R*	4.0	0.7	0.6	0.4	0.3	0.3
	5.5	1.3	1.1	0.9	0.7	0.6
	7.0	1.9	1.7	1.5	1.3	1.2
	8.5	2.6	2.4	2.2	2.0	1.9
040H/R	5.0	0.9	0.6	0.6	0.5	0.5
	7.5	2.3	2.1	2.0	1.9	1.8
	10.0	3.7	3.5	3.3	3.2	3.0
	12.5	5.0	4.7	4.4	4.2	4.0
050H/R	8.0	1.7	1.4	1.4	1.3	1.3
	11.5	3.6	3.4	3.2	3.0	2.8
	15.0	5.6	5.4	5.0	4.6	4.2
	18.5	8.3	8.1	7.6	7.2	6.8
060H/R	9.0	1.4	1.1	1.0	1.0	0.9
	13.5	4.2	3.9	3.5	3.1	2.7
	18.0	6.9	6.7	6.0	5.2	4.5
	22.5	10.7	10.5	10.0	9.4	8.7
075H/R	10.0	3.2	3.0	2.8	2.7	2.5
	14.5	5.5	5.3	5.1	4.9	4.7
	19.0	7.9	7.6	7.3	7.1	6.8
	23.5	11.5	11.3	11.0	10.8	10.5

NOTES: Temperatures are Entering Water Temperatures
 *Domestic water heating units source side pressure drop and reversible units load and source pressure drop. 8/9/10

Vented Only Load Side

Model	GPM	Pressure Drop (psi)			
		60°F	80°F	100°F	120°F
018H	3.0	0.5	0.4	0.4	0.3
	4.0	1.4	1.3	1.2	1.2
	5.0	2.2	2.1	2.1	2.0
	6.0	3.0	2.9	2.9	2.8
025H	4.0	1.3	1.3	1.2	1.2
	5.5	3.0	2.9	2.8	2.7
	7.0	4.6	4.4	4.3	4.1
	8.5	6.7	6.5	6.4	6.2

NOTES: Temperatures are Entering Water Temperatures. 7/13/09
 Double wall vented coax for heating potable water

Reference Calculations

<p>Heating Calculations:</p> $LWT = EWT - \frac{HE}{GPM \times C^*}$ $HE = C^* \times GPM \times (EWT - LWT)$	<p>Cooling Calculations:</p> $LWT = EWT + \frac{HR}{GPM \times C^*}$ $HR = C^* \times GPM \times (LWT - EWT)$
--	--

NOTE: * C = 500 for pure water, 485 for brine.

Legend and Notes

Abbreviations and Definitions

ELT = entering load fluid temperature to heat pump	kW = kilowatts
SWPD = source coax water pressure drop	EST = entering source fluid temperature to heat pump
LLT = leaving load fluid temperature from heat pump	HE = heat extracted in MBTUH
PSI = pressure drop in pounds per square inch	LST = leaving source fluid temperature from heat pump
LGPM = load flow in gallons per minute	HC = total heating capacity in MBTUH
FT HD = pressure drop in feet of head	COP = coefficient of performance, heating [HC/kW x 3.413]
LWPD = load coax water pressure drop	EER = energy efficiency ratio, cooling
LWT = leaving water temperature	TC = total cooling capacity in MBTUH
EWT = entering water temperature	HR = heat rejected in MBTUH
Brine = water with a freeze inhibiting solution	

Notes to Performance Data Tables

The following notes apply to all performance data tables:

- Three flow rates are shown for each unit. The lowest flow rate shown is used for geothermal open loop/well water systems with a minimum of 50°F EST. The middle flow rate shown is the minimum geothermal closed loop flow rate. The highest flow rate shown is optimum for geothermal closed loop systems and the suggested flow rate for boiler/tower applications.
- Entering water temperatures below 40°F assumes 15% antifreeze solution.
- Interpolation between ELT, EST, and GPM data is permissible.
- Operation in the gray areas is not recommended.

018 - Performance Data

Cooling Capacity

Source		Load Flow-3 GPM							Load Flow-4 GPM							Load Flow-5 GPM						
EST °F	Flow GPM	ELT °F	LLT °F	TC MBTUH	Power kW	HR MBTUH	EER	LST °F	LLT °F	TC MBTUH	Power kW	HR MBTUH	EER	LST °F	LLT °F	TC MBTUH	Power kW	HR MBTUH	EER	LST °F		
30	3	50	37.8	17.8	0.60	19.8	29.7	43.6	40.1	18.1	0.61	20.1	29.8	43.8	42.5	18.3	0.61	20.4	30.0	44.0		
		70	56.8	19.3	0.59	21.3	32.5	44.6	59.3	19.4	0.60	21.5	32.6	44.8	61.9	19.6	0.60	21.6	32.7	44.9		
		90	75.8	20.7	0.59	22.7	35.3	45.6	78.6	20.8	0.59	22.8	35.4	45.7	81.4	20.9	0.59	22.9	35.4	45.7		
		110	94.7	22.2	0.58	24.2	38.3	46.6	97.8	22.2	0.58	24.2	38.3	46.6	100.8	22.2	0.58	24.2	38.3	46.6		
	4	50	37.7	18.0	0.58	19.9	30.9	40.9	40.0	18.2	0.58	20.2	31.2	41.1	42.4	18.4	0.59	20.4	31.5	41.2		
		70	56.7	19.3	0.57	21.3	33.8	41.7	59.3	19.5	0.57	21.4	34.0	41.8	61.9	19.6	0.58	21.6	34.1	41.9		
		90	75.8	20.7	0.56	22.6	36.7	42.4	78.6	20.8	0.56	22.7	36.8	42.5	81.4	20.9	0.57	22.8	36.9	42.5		
		110	94.9	22.0	0.56	23.9	39.6	43.2	97.9	22.1	0.56	23.9	39.7	43.2	100.9	22.1	0.56	24.0	39.8	43.2		
	5	50	37.6	18.1	0.56	20.0	32.3	38.3	40.0	18.3	0.56	20.2	32.7	38.3	42.4	18.5	0.56	20.4	33.0	38.4		
		70	56.7	19.3	0.55	21.2	35.2	38.7	59.3	19.5	0.55	21.4	35.5	38.8	61.9	19.7	0.55	21.5	35.8	38.9		
		90	75.9	20.6	0.54	22.4	38.1	39.2	78.6	20.7	0.54	22.5	38.3	39.3	81.4	20.8	0.54	22.7	38.6	39.4		
		110	95.0	21.8	0.53	23.6	41.1	39.7	98.0	21.9	0.53	23.7	41.3	39.8	100.9	22.0	0.53	23.8	41.5	39.8		
50	3	50	38.4	16.9	0.80	19.6	22.9	63.4	40.5	17.3	0.80	20.0	23.3	63.8	42.7	17.8	0.80	20.5	23.7	64.1		
		70	56.3	19.9	0.80	22.6	26.5	65.5	58.9	20.2	0.80	22.9	26.8	65.8	61.5	20.6	0.80	23.3	27.2	66.0		
		90	74.3	22.9	0.80	25.6	30.1	67.6	77.3	23.1	0.79	25.8	30.4	67.8	80.4	23.4	0.79	26.1	30.7	67.9		
		110	92.2	25.9	0.80	28.6	33.8	69.7	95.7	26.1	0.79	28.8	34.0	69.8	99.2	26.2	0.79	28.9	34.2	69.9		
	4	50	38.3	17.0	0.77	19.6	22.0	60.8	40.5	17.4	0.77	20.0	22.6	61.0	42.6	17.8	0.77	20.5	23.1	61.2		
		70	56.3	19.9	0.77	22.5	26.0	62.4	58.9	20.3	0.76	22.9	26.5	62.6	61.5	20.6	0.76	23.2	27.0	62.8		
		90	74.3	22.9	0.76	25.5	30.2	64.0	77.3	23.1	0.76	25.7	30.5	64.2	80.4	23.4	0.76	25.9	30.9	64.3		
		110	92.2	25.9	0.75	28.4	34.4	65.7	95.7	26.0	0.75	28.6	34.6	65.7	99.2	26.1	0.75	28.7	34.8	65.8		
	5	50	38.2	17.1	0.75	19.7	24.7	58.1	40.4	17.5	0.75	20.0	25.3	58.3	42.6	17.9	0.74	20.4	25.9	58.4		
		70	56.3	20.0	0.74	22.5	28.8	59.3	58.9	20.3	0.73	22.8	29.2	59.4	61.5	20.6	0.73	23.1	29.7	59.5		
		90	74.3	22.9	0.72	25.4	33.0	60.5	77.3	23.1	0.72	25.6	33.3	60.5	80.4	23.3	0.72	25.8	33.6	60.6		
		110	92.3	25.8	0.71	28.2	37.3	61.6	95.8	25.9	0.71	28.3	37.5	61.7	99.3	26.1	0.71	28.5	37.7	61.7		
70	3	50	39.1	15.9	0.99	19.3	16.1	83.3	41.0	16.6	0.99	19.9	16.7	83.7	42.9	17.2	0.99	20.6	17.4	84.1		
		70	55.9	20.5	1.00	23.9	20.5	86.4	58.5	21.0	1.00	24.4	21.1	86.8	61.1	21.5	0.99	24.9	21.7	87.1		
		90	Operation not recommended																			
		110	Operation not recommended																			
	4	50	39.0	16.0	0.97	19.3	16.6	80.6	40.9	16.6	0.96	19.9	17.3	80.9	42.9	17.3	0.96	20.5	18.1	81.3		
		70	55.9	20.6	0.96	23.8	21.4	83.1	58.5	21.1	0.96	24.3	22.0	83.4	61.1	21.6	0.95	24.8	22.6	83.7		
		90	Operation not recommended																			
		110	Operation not recommended																			
	5	50	38.9	16.1	0.94	19.3	17.1	78.0	40.9	16.7	0.93	19.9	18.0	78.2	42.9	17.3	0.92	20.4	18.8	78.4		
		70	55.8	20.7	0.92	23.8	22.4	79.8	58.5	21.1	0.92	24.2	23.0	80.0	61.1	21.6	0.91	24.7	23.7	80.2		
		90	Operation not recommended																			
		110	Operation not recommended																			
90	3	50	40.4	14.0	1.30	18.4	11.8	102.7	42.1	14.5	1.30	19.0	12.3	103.0	43.8	15.1	1.30	19.5	12.7	103.4		
		70	57.4	18.3	1.30	22.7	15.3	105.6	59.8	18.7	1.30	23.2	15.7	105.9	62.1	19.2	1.30	23.6	16.1	106.2		
		90	Operation not recommended																			
		110	Operation not recommended																			
	4	50	40.3	14.1	1.27	18.4	11.2	100.1	42.0	14.6	1.26	19.0	11.6	100.4	43.8	15.2	1.26	19.5	12.0	100.7		
		70	57.3	18.4	1.26	22.7	14.6	102.5	59.7	18.9	1.26	23.1	15.0	102.7	62.0	19.3	1.26	23.6	15.4	103.0		
		90	Operation not recommended																			
		110	Operation not recommended																			
	5	50	40.2	14.3	1.24	18.5	12.6	97.6	42.0	14.8	1.23	18.9	13.2	97.8	43.7	15.3	1.23	19.4	13.7	98.0		
		70	57.2	18.6	1.22	22.7	16.6	99.4	59.6	19.0	1.21	23.1	17.1	99.5	62.0	19.4	1.21	23.5	17.5	99.7		
		90	Operation not recommended																			
		110	Operation not recommended																			
110	3	50	41.7	12.1	1.60	17.6	7.6	122.1	43.2	12.5	1.61	18.0	7.8	122.4	44.7	12.9	1.61	18.4	8.0	122.6		
		70	59.0	16.1	1.60	21.5	10.0	124.8	61.0	16.5	1.60	21.9	10.3	125.1	63.1	16.8	1.61	22.3	10.5	125.3		
		90	Operation not recommended																			
		110	Operation not recommended																			
	4	50	41.6	12.3	1.57	17.6	7.8	119.7	43.1	12.7	1.57	18.0	8.1	119.9	44.6	13.1	1.57	18.4	8.3	120.1		
		70	58.8	16.3	1.56	21.6	10.5	121.9	60.9	16.6	1.56	22.0	10.7	122.1	63.0	17.0	1.56	22.3	10.9	122.3		
		90	Operation not recommended																			
		110	Operation not recommended																			
	5	50	41.5	12.4	1.53	17.6	8.1	117.3	43.0	12.8	1.53	18.0	8.4	117.4	44.6	13.2	1.53	18.4	8.6	117.6		
		70	58.7	16.5	1.51	21.6	10.9	118.9	60.8	16.8	1.51	22.0	11.1	119.1	62.9	17.2	1.51	22.4	11.4	119.2		
		90	Operation not recommended																			
		110	Operation not recommended																			

018 DHW - Performance Data cont.

Heating Only Capacity

Source		Load Flow-3 GPM							Load Flow-4 GPM							Load Flow-5 GPM						
EST °F	Flow GPM	ELT °F	LLT °F	HC MBTUH	Power kW	HE MBTUH	COP	LST °F	LLT °F	HC MBTUH	Power kW	HE MBTUH	COP	LST °F	LLT °F	HC MBTUH	Power kW	HE MBTUH	COP	LST °F		
25	4	60	Operation not recommended																			
		80	Operation not recommended																			
		100	Operation not recommended																			
		120	Operation not recommended																			
	5	60	70.0	14.5	0.97	11.2	4.38	20.4	67.6	14.7	0.95	11.4	4.52	20.3	66.1	14.8	0.93	11.6	4.66	20.2		
		80	89.7	14.1	1.30	9.7	3.19	21.0	87.4	14.3	1.28	9.9	3.27	20.9	85.9	14.4	1.26	10.1	3.36	20.8		
		100	109.5	13.8	1.62	8.2	2.48	21.6	107.2	13.9	1.60	8.4	2.54	21.5	105.8	14.0	1.58	8.6	2.59	21.5		
		120	129.2	13.4	1.95	6.7	2.01	22.2	127.0	13.5	1.93	6.9	2.05	22.1	125.6	13.6	1.91	7.1	2.09	22.1		
30	3	60	70.4	15.2	0.97	11.9	4.59	21.8	68.4	15.4	0.95	12.1	4.74	21.7	66.4	15.5	0.93	12.3	4.88	21.5		
		80	90.2	14.9	1.30	10.4	3.35	22.8	88.2	15.0	1.28	10.6	3.43	22.7	86.2	15.1	1.26	10.8	3.52	22.6		
		100	110.0	14.5	1.63	9.0	2.61	23.8	108.0	14.7	1.61	9.2	2.67	23.7	106.1	14.8	1.59	9.3	2.72	23.6		
		120	129.8	14.2	1.96	7.5	2.12	24.8	127.8	14.3	1.94	7.7	2.16	24.7	125.9	14.4	1.92	7.8	2.20	24.6		
	4	60	70.7	15.6	0.97	12.3	4.71	23.3	68.6	15.8	0.95	12.5	4.86	23.2	66.6	15.9	0.93	12.7	5.01	23.1		
		80	90.4	15.2	1.30	10.8	3.43	24.1	88.4	15.3	1.28	11.0	3.51	24.0	86.4	15.5	1.26	11.2	3.60	23.9		
		100	110.2	14.8	1.63	9.2	2.66	25.0	108.2	14.9	1.61	9.4	2.71	24.9	106.2	15.0	1.59	9.6	2.77	24.8		
		120	129.9	14.4	1.96	7.7	2.15	25.8	127.9	14.5	1.94	7.9	2.19	25.7	126.0	14.6	1.92	8.0	2.23	25.6		
	5	60	71.0	16.0	0.97	12.7	4.83	24.8	68.9	16.2	0.95	12.9	4.98	24.7	66.7	16.3	0.93	13.1	5.14	24.6		
		80	90.7	15.5	1.30	11.1	3.50	25.4	88.6	15.7	1.28	11.3	3.59	25.3	86.5	15.8	1.26	11.5	3.68	25.3		
		100	110.4	15.1	1.63	9.5	2.71	26.1	108.3	15.2	1.61	9.7	2.76	26.0	106.3	15.2	1.58	9.8	2.82	25.9		
		120	130.0	14.6	1.96	7.9	2.18	26.7	128.0	14.7	1.94	8.0	2.22	26.7	126.1	14.7	1.91	8.2	2.26	26.6		
50	3	60	73.4	19.6	0.98	16.2	5.87	38.9	70.8	19.8	0.95	16.5	6.10	38.7	68.2	20.0	0.93	16.8	6.33	38.5		
		80	93.0	18.9	1.31	14.4	4.23	40.1	90.5	19.1	1.28	14.7	4.37	39.9	87.9	19.3	1.25	15.0	4.51	39.7		
		100	112.5	18.3	1.64	12.7	3.26	41.3	110.1	18.4	1.61	12.9	3.35	41.1	107.6	18.6	1.58	13.2	3.44	41.0		
		120	132.1	17.6	1.97	10.9	2.62	42.5	129.7	17.7	1.94	11.1	2.68	42.4	127.4	17.9	1.91	11.3	2.74	42.2		
	4	60	73.8	20.1	0.98	16.7	6.03	40.9	71.1	20.3	0.95	17.0	6.26	40.7	68.5	20.5	0.93	17.3	6.49	40.5		
		80	93.3	19.4	1.31	14.9	4.34	41.9	90.7	19.5	1.28	15.2	4.47	41.7	88.1	19.7	1.25	15.4	4.61	41.6		
		100	112.8	18.6	1.64	13.0	3.33	42.9	110.3	18.8	1.61	13.3	3.41	42.8	107.8	18.9	1.58	13.5	3.50	42.6		
		120	132.3	17.9	1.97	11.2	2.66	43.9	129.9	18.0	1.94	11.4	2.72	43.8	127.5	18.1	1.91	11.6	2.78	43.7		
	5	60	74.2	20.6	0.98	17.3	6.18	42.9	71.4	20.8	0.95	17.6	6.43	42.7	68.7	21.1	0.93	17.9	6.68	42.6		
		80	93.6	19.8	1.31	15.3	4.44	43.7	91.0	20.0	1.28	15.6	4.58	43.6	88.3	20.1	1.25	15.9	4.72	43.5		
		100	113.1	19.0	1.64	13.4	3.39	44.5	110.5	19.1	1.61	13.6	3.48	44.4	107.9	19.2	1.58	13.8	3.57	44.3		
		120	132.5	18.2	1.97	11.5	2.70	45.3	130.0	18.3	1.94	11.6	2.76	45.2	127.5	18.3	1.91	11.8	2.82	45.1		
70	3	60	76.4	23.9	0.98	20.6	7.15	55.9	73.2	24.2	0.95	20.9	7.46	55.6	70.1	24.4	0.92	21.3	7.77	55.4		
		80	95.8	22.9	1.31	18.5	5.12	57.3	92.7	23.2	1.28	18.8	5.30	57.1	89.6	23.4	1.25	19.1	5.49	56.9		
		100	115.1	22.0	1.65	16.3	3.91	58.8	112.2	22.2	1.61	16.7	4.03	58.6	109.2	22.3	1.57	17.0	4.16	58.3		
		120	134.4	21.0	1.98	14.2	3.11	60.2	131.6	21.2	1.94	14.5	3.20	60.0	128.8	21.3	1.90	14.8	3.28	59.8		
	4	60	76.9	24.6	0.98	21.2	7.34	58.4	73.6	24.8	0.95	21.6	7.66	58.2	70.4	25.1	0.92	22.0	7.99	58.0		
		80	96.2	23.5	1.31	19.0	5.24	59.6	93.0	23.7	1.28	19.3	5.43	59.4	89.9	23.9	1.25	19.7	5.62	59.3		
		100	115.4	22.5	1.65	16.8	3.99	60.8	112.4	22.6	1.61	17.1	4.11	60.7	109.4	22.8	1.57	17.4	4.24	60.5		
		120	134.7	21.4	1.98	14.6	3.17	62.0	131.8	21.5	1.94	14.9	3.25	61.9	128.9	21.6	1.90	15.1	3.33	61.7		
	5	60	77.3	25.2	0.98	21.9	7.53	61.0	74.0	25.5	0.95	22.3	7.88	60.8	70.6	25.8	0.92	22.7	8.22	60.7		
		80	96.5	24.1	1.31	19.6	5.37	61.9	93.3	24.3	1.28	19.9	5.56	61.8	90.1	24.5	1.25	20.2	5.76	61.7		
		100	115.8	22.9	1.65	17.3	4.08	62.9	112.7	23.1	1.61	17.6	4.20	62.8	109.6	23.2	1.57	17.8	4.32	62.6		
		120	135.0	21.8	1.98	15.0	3.23	63.8	132.0	21.9	1.94	15.2	3.30	63.7	129.0	21.9	1.90	15.4	3.38	63.6		
90	3	60	79.2	28.0	0.98	24.7	8.37	73.1	79.3	28.2	0.95	24.9	8.69	72.9	79.5	28.3	0.92	25.2	9.01	72.7		
		80	98.2	26.5	1.31	22.0	5.93	74.9	98.4	26.7	1.27	22.4	6.16	74.6	98.5	27.0	1.24	22.7	6.39	74.4		
		100	Operation not recommended																			
		120	Operation not recommended																			
	4	60	Operation not recommended																			
		80	Operation not recommended																			
		100	Operation not recommended																			
		120	Operation not recommended																			
	5	60	Operation not recommended																			
		80	Operation not recommended																			
		100	Operation not recommended																			
		120	Operation not recommended																			

025 DHW - Performance Data cont.

Heating Only Capacity

Source		Load Flow-4 GPM							Load Flow-5.5 GPM							Load Flow-7 GPM						
EST °F	Flow GPM	ELT °F	LLT °F	HC MBTUH	Power kW	HE MBTUH	COP	LST °F	LLT °F	HC MBTUH	Power kW	HE MBTUH	COP	LST °F	LLT °F	HC MBTUH	Power kW	HE MBTUH	COP	LST °F		
25	5.5	60	Operation not recommended																			
		80	Operation not recommended																			
		100	Operation not recommended																			
		120	Operation not recommended																			
25	7	60	71.1	21.6	1.40	16.8	4.52	20.0	68.1	21.7	1.39	17.0	4.59	20.0	66.4	21.8	1.37	17.1	4.66	20.0		
		80	90.8	20.9	1.84	14.6	3.33	20.7	87.9	21.1	1.79	14.9	3.44	20.6	86.2	21.2	1.74	15.2	3.56	20.5		
		100	110.4	20.3	2.29	12.5	2.60	21.3	107.6	20.4	2.20	12.9	2.72	21.2	106.0	20.5	2.11	13.3	2.85	21.1		
		120	130.1	19.6	2.73	10.3	2.10	22.0	127.4	19.8	2.61	10.9	2.22	21.8	125.9	19.9	2.48	11.4	2.35	21.6		
30	4	60	71.7	22.7	1.41	17.9	4.72	20.8	69.2	22.8	1.38	18.0	4.83	20.7	66.7	22.8	1.35	18.2	4.95	20.6		
		80	91.4	22.1	1.86	15.7	3.48	21.9	89.0	22.1	1.77	16.1	3.67	21.7	86.5	22.2	1.68	16.4	3.87	21.5		
		100	111.0	21.4	2.31	13.5	2.72	23.0	108.7	21.5	2.16	14.1	2.93	22.7	106.3	21.5	2.00	14.7	3.15	22.4		
		120	130.7	20.8	2.76	11.4	2.21	24.1	128.4	20.9	2.55	12.2	2.42	23.7	126.2	20.9	2.33	12.9	2.63	23.3		
	30	5.5	60	72.0	23.3	1.42	18.4	4.81	22.6	69.4	23.3	1.38	18.6	4.94	22.5	66.9	23.4	1.35	18.8	5.08	22.5	
			80	91.6	22.5	1.87	16.2	3.54	23.5	89.1	22.6	1.80	16.5	3.68	23.4	86.7	22.7	1.73	16.8	3.84	23.2	
			100	111.2	21.8	2.32	13.9	2.76	24.4	108.9	21.9	2.21	14.3	2.90	24.2	106.5	22.0	2.11	14.8	3.05	24.0	
			120	130.9	21.1	2.77	11.7	2.24	25.3	128.6	21.2	2.63	12.2	2.36	25.1	126.3	21.3	2.50	12.7	2.50	24.8	
	30	7	60	72.3	23.8	1.42	19.0	4.91	24.4	69.7	23.9	1.39	19.2	5.06	24.4	67.1	24.0	1.35	19.4	5.21	24.3	
			80	91.9	23.0	1.87	16.6	3.60	25.1	89.3	23.1	1.83	16.9	3.70	25.0	86.8	23.2	1.79	17.1	3.80	25.0	
			100	111.4	22.2	2.32	14.3	2.80	25.8	109.0	22.3	2.27	14.5	2.88	25.7	106.6	22.4	2.22	14.8	2.95	25.6	
			120	131.0	21.4	2.77	11.9	2.26	26.5	128.7	21.5	2.72	12.2	2.32	26.4	126.4	21.6	2.66	12.5	2.38	26.3	
50	4	60	75.2	29.5	1.47	24.4	5.85	37.4	71.9	29.5	1.42	24.7	6.06	37.3	68.7	29.6	1.38	24.9	6.27	37.2		
		80	94.6	28.3	1.92	21.7	4.28	38.8	91.5	28.4	1.84	22.1	4.48	38.6	88.4	28.5	1.77	22.4	4.68	38.4		
		100	114.0	27.1	2.38	19.0	3.32	40.2	111.0	27.2	2.27	19.5	3.50	40.0	108.1	27.4	2.16	20.0	3.68	39.7		
		120	133.4	25.9	2.84	16.2	2.66	41.6	130.5	26.1	2.69	16.9	2.83	41.3	127.7	26.3	2.55	17.6	2.99	40.9		
	50	5.5	60	75.6	30.3	1.47	25.3	6.03	39.8	72.3	30.4	1.43	25.5	6.25	39.8	69.0	30.5	1.38	25.7	6.48	39.7	
			80	95.0	29.0	1.93	22.4	4.41	41.0	91.8	29.1	1.86	22.8	4.58	40.9	88.6	29.2	1.80	23.1	4.77	40.7	
			100	114.3	27.7	2.38	19.6	3.41	42.1	111.3	27.9	2.30	20.0	3.55	41.9	108.3	28.0	2.21	20.5	3.71	41.8	
			120	133.6	26.4	2.84	16.7	2.72	43.3	130.8	26.6	2.74	17.3	2.85	43.0	127.9	26.8	2.63	17.8	2.99	42.8	
	50	7	60	76.1	31.2	1.48	26.1	6.13	42.3	72.7	31.3	1.43	26.4	6.38	42.2	69.2	31.4	1.38	26.6	6.63	42.2	
			80	95.3	29.8	1.94	23.2	4.48	43.2	92.1	29.9	1.88	23.5	4.64	43.1	88.8	30.0	1.83	23.8	4.80	43.0	
			100	114.6	28.3	2.39	20.2	3.45	44.1	111.5	28.5	2.33	20.6	3.57	43.9	108.5	28.7	2.27	21.0	3.69	43.8	
			120	133.9	26.9	2.85	17.2	2.76	44.9	131.0	27.2	2.78	17.7	2.85	44.8	128.1	27.4	2.72	18.1	2.95	44.7	
70	4	60	78.7	36.2	1.52	31.0	6.98	54.0	74.7	36.3	1.46	31.3	7.29	53.9	70.7	36.3	1.40	31.5	7.60	53.8		
		80	97.8	34.5	1.98	27.7	5.09	55.7	94.0	34.6	1.92	28.1	5.29	55.5	90.2	34.7	1.85	28.4	5.49	55.4		
		100	116.9	32.7	2.45	24.4	3.92	57.4	113.3	33.0	2.38	24.8	4.07	57.2	109.8	33.2	2.31	25.3	4.21	57.0		
		120	136.0	31.0	2.91	21.1	3.12	59.1	132.6	31.3	2.84	21.6	3.24	58.9	129.3	31.6	2.76	22.2	3.35	58.6		
	70	5.5	60	79.3	37.4	1.53	32.2	7.16	57.1	75.2	37.5	1.47	32.4	7.48	57.0	71.0	37.5	1.41	32.7	7.82	56.9	
			80	98.3	35.5	1.99	28.7	5.22	58.5	94.4	35.7	1.93	29.1	5.43	58.3	90.5	35.8	1.86	29.5	5.64	58.2	
			100	117.3	33.6	2.45	25.2	4.01	59.9	113.7	33.9	2.38	25.7	4.16	59.7	110.0	34.1	2.31	26.2	4.32	59.5	
			120	136.3	31.7	2.92	21.8	3.19	61.3	132.9	32.1	2.84	22.4	3.31	61.0	129.5	32.4	2.77	23.0	3.43	60.8	
	70	7	60	79.9	38.6	1.54	33.3	7.34	60.2	75.6	38.7	1.48	33.6	7.69	60.1	71.4	38.7	1.41	33.9	8.04	60.0	
			80	98.8	36.5	2.00	29.7	5.35	61.2	94.8	36.7	1.93	30.1	5.57	61.1	90.9	36.9	1.86	30.5	5.80	61.0	
			100	117.8	34.5	2.46	26.1	4.11	62.3	114.0	34.8	2.39	26.6	4.27	62.2	110.3	35.0	2.32	27.1	4.43	62.0	
			120	136.7	32.4	2.92	22.4	3.25	63.4	133.2	32.8	2.85	23.1	3.38	63.2	129.8	33.2	2.77	23.7	3.51	63.0	
90	4	60	82.0	42.7	1.56	37.4	8.02	70.7	82.2	43.0	1.49	37.9	8.48	70.5	82.3	43.3	1.42	38.5	8.93	70.2		
		80	100.9	40.5	2.02	33.6	5.86	72.7	101.0	40.8	1.95	34.2	6.15	72.4	101.2	41.1	1.87	34.8	6.44	72.1		
		100	Operation not recommended																			
		120	Operation not recommended																			
	90	5.5	60	Operation not recommended																		
			80	Operation not recommended																		
			100	Operation not recommended																		
			120	Operation not recommended																		
	90	7	60	Operation not recommended																		
			80	Operation not recommended																		
			100	Operation not recommended																		
			120	Operation not recommended																		

040 - Performance Data

Cooling Capacity

Source		Load Flow-5 GPM							Load Flow-7.5 GPM							Load Flow-10 GPM						
EST °F	Flow GPM	ELT °F	LLT °F	TC MBTUH	Power kW	HR MBTUH	EER	LST °F	LLT °F	TC MBTUH	Power kW	HR MBTUH	EER	LST °F	LLT °F	TC MBTUH	Power kW	HR MBTUH	EER	LST °F		
30	5	50	34.0	38.7	1.38	43.4	28.0	47.9	37.8	39.8	1.39	44.5	28.7	48.4	41.6	40.9	1.39	45.6	29.4	48.8		
		70	54.5	37.5	1.27	41.8	29.4	47.2	58.3	38.0	1.25	42.3	30.4	47.4	62.0	38.6	1.23	42.8	31.4	47.6		
		90	75.1	36.2	1.17	40.2	31.1	46.6	78.8	36.2	1.12	40.0	32.6	46.5	82.5	36.2	1.06	39.9	34.1	46.4		
	7.5	50	34.5	37.7	1.32	42.2	28.6	43.2	38.2	38.6	1.33	43.1	29.1	43.5	41.9	39.4	1.33	43.9	29.6	43.8		
		70	55.1	36.2	1.23	40.4	29.6	42.6	58.7	36.7	1.21	40.8	30.3	42.8	62.3	37.1	1.19	41.2	31.2	42.9		
		90	75.7	34.7	1.13	38.6	30.7	42.1	79.3	34.8	1.09	38.5	31.9	42.1	82.8	34.9	1.05	38.5	33.1	42.0		
	10	50	34.9	36.7	1.26	41.0	29.1	38.5	38.5	37.3	1.27	41.6	29.5	38.6	42.2	37.9	1.27	42.2	29.8	38.7		
		70	55.6	34.9	1.18	38.9	29.7	38.0	59.1	35.3	1.17	39.3	30.3	38.1	62.6	35.7	1.16	39.6	30.9	38.2		
		90	76.3	33.2	1.09	36.9	30.3	37.6	79.7	33.3	1.07	37.0	31.2	37.6	83.1	33.5	1.04	37.1	32.1	37.6		
	50	5	50	35.3	35.7	1.76	41.7	21.6	67.2	38.6	37.4	1.76	43.4	22.6	67.9	41.9	39.2	1.76	45.2	23.5	68.6	
			70	53.4	40.2	1.73	46.1	24.5	69.0	57.3	41.5	1.72	47.4	25.5	69.5	61.2	42.8	1.71	48.6	26.4	70.1	
			90	71.5	44.8	1.71	50.6	27.4	70.9	76.0	45.6	1.69	51.4	28.5	71.2	80.4	46.4	1.66	52.1	29.5	71.5	
7.5		50	39.1	35.3	1.69	41.0	20.9	62.8	38.8	36.9	1.68	42.6	21.9	63.3	42.1	38.5	1.68	44.2	22.9	63.8		
		70	57.8	39.2	1.65	44.8	23.7	64.0	58.7	40.3	1.64	45.9	24.5	64.4	61.4	41.5	1.63	47.1	25.4	64.7		
		90	76.5	43.0	1.62	48.6	26.5	65.2	77.8	43.8	1.60	49.2	27.3	65.4	80.8	44.5	1.59	49.9	28.1	65.7		
10		50	42.8	34.9	1.61	40.4	23.0	58.3	38.9	36.4	1.61	41.9	23.8	58.6	42.2	37.9	1.61	43.3	24.7	58.9		
		70	62.1	38.1	1.57	43.5	25.3	59.0	60.1	39.1	1.57	44.5	26.1	59.2	61.7	40.2	1.56	45.5	26.9	59.4		
		90	81.5	41.3	1.54	46.5	27.6	59.6	79.6	41.9	1.52	47.1	28.4	59.7	81.2	42.6	1.51	47.7	29.1	59.8		
70		5	50	36.6	32.6	2.14	39.9	15.2	86.5	39.4	35.0	2.14	42.3	16.4	87.4	42.3	37.4	2.13	44.7	17.6	88.4	
			70	52.3	43.0	2.19	50.5	19.6	90.8	56.3	45.0	2.20	52.5	20.5	91.6	60.3	47.0	2.20	54.5	21.4	92.5	
			90	68.0	53.3	2.25	61.0	23.7	95.2	73.2	55.0	2.26	62.7	24.4	95.8	78.3	56.6	2.26	64.3	25.0	96.5	
	7.5	50	36.5	32.9	2.05	39.8	16.0	82.3	39.4	35.2	2.04	42.2	17.2	83.1	42.2	37.6	2.04	44.5	18.5	83.8		
		70	56.9	42.1	2.08	49.2	20.2	85.3	58.7	44.0	2.08	51.1	21.2	85.9	60.5	45.9	2.08	52.9	22.1	86.5		
		90	73.9	51.4	2.11	58.6	24.3	88.4	76.4	52.7	2.12	59.9	24.9	88.8	78.8	54.1	2.12	61.3	25.5	89.3		
	10	50	36.4	33.1	1.96	39.8	16.9	78.2	39.3	35.5	1.95	42.1	18.2	78.7	42.2	37.8	1.94	44.4	19.5	79.2		
		70	61.5	41.2	1.97	48.0	20.9	79.9	61.1	43.0	1.96	49.7	21.9	80.2	60.8	44.7	1.96	51.4	22.8	80.6		
		90	79.8	49.4	1.98	56.1	24.9	81.6	79.6	50.5	1.98	57.2	25.5	81.8	79.4	51.6	1.97	58.3	26.1	82.0		
	90	5	50	38.0	29.1	2.74	38.4	11.4	105.8	40.6	30.9	2.74	40.3	12.2	106.6	43.2	32.8	2.74	42.2	13.0	107.4	
			70	53.8	39.2	2.80	48.8	15.0	110.1	57.5	41.1	2.81	50.7	15.7	110.9	61.1	43.0	2.81	52.6	16.4	111.7	
			90	69.6	49.4	2.86	59.1	18.4	114.4	74.3	51.3	2.87	61.1	19.0	115.2	79.0	53.3	2.88	63.1	19.6	116.0	
7.5		50	41.0	29.2	2.65	38.3	11.0	101.8	40.6	31.1	2.64	40.1	11.8	102.4	43.2	33.0	2.64	42.0	12.5	103.0		
		70	57.9	38.9	2.68	48.1	14.5	104.9	59.6	40.8	2.68	49.9	15.2	105.5	61.2	42.7	2.68	51.8	15.9	106.1		
		90	74.9	48.6	2.71	57.9	17.9	108.0	77.0	50.5	2.71	59.7	18.6	108.6	79.2	52.3	2.71	61.6	19.3	109.2		
10		50	43.9	29.4	2.55	38.1	12.5	97.9	40.5	31.3	2.54	40.0	13.4	98.2	43.1	33.3	2.54	41.9	14.3	98.6		
		70	62.0	38.7	2.56	47.4	16.2	99.8	61.7	40.5	2.55	49.2	17.0	100.1	61.3	42.3	2.54	51.0	17.8	100.5		
		90	80.1	47.9	2.56	56.6	19.8	101.7	79.8	49.6	2.56	58.4	20.6	102.0	79.4	51.4	2.55	60.1	21.3	102.4		
110		5	50	39.5	25.5	3.34	36.9	7.6	125.2	41.8	26.9	3.35	38.3	8.0	125.8	44.2	28.2	3.35	39.6	8.4	126.3	
			70	55.4	35.5	3.41	47.1	10.4	129.4	58.7	37.3	3.42	48.9	10.9	130.2	61.9	39.1	3.42	50.8	11.4	130.9	
			90																			
	7.5	50	39.4	25.6	3.24	36.7	7.9	121.4	41.8	27.0	3.24	38.1	8.3	121.8	44.1	28.5	3.24	39.5	8.8	122.2		
		70	59.0	35.8	3.28	46.9	10.9	124.5	60.4	37.6	3.28	48.8	11.5	125.1	61.9	39.5	3.28	50.7	12.1	125.7		
		90																				
	10	50	39.4	25.7	3.14	36.4	8.2	117.5	41.7	27.2	3.14	37.9	8.7	117.8	44.1	28.7	3.13	39.4	9.2	118.1		
		70	62.6	36.1	3.14	46.8	11.5	119.6	62.2	38.0	3.14	48.7	12.1	120.0	61.8	39.9	3.13	50.6	12.8	120.4		
		90																				

040 - Performance Data cont.

Heating Capacity

Source		Load Flow-5 GPM							Load Flow-7.5 GPM							Load Flow-10 GPM						
EST °F	Flow GPM	ELT °F	LLT °F	HC MBTUH	Power kW	HE MBTUH	COP	LST °F	LLT °F	HC MBTUH	Power kW	HE MBTUH	COP	LST °F	LLT °F	HC MBTUH	Power kW	HE MBTUH	COP	LST °F		
25	7.5	60	Operation not recommended																			
		80	Operation not recommended																			
		100	Operation not recommended																			
		120	Operation not recommended																			
	10	60	72.2	29.7	1.83	23.5	4.76	20.2	68.2	29.7	1.78	23.6	4.89	20.1	66.1	29.6	1.72	23.7	5.04	20.1		
		80	91.9	28.8	2.42	20.6	3.50	20.8	87.9	28.8	2.36	20.7	3.58	20.7	85.9	28.7	2.29	20.9	3.67	20.7		
		100	111.5	28.0	3.00	17.7	2.73	21.3	107.7	27.9	2.94	17.9	2.78	21.3	105.7	27.8	2.87	18.0	2.84	21.3		
		120	131.2	27.1	3.59	14.8	2.21	21.9	127.4	27.0	3.52	15.0	2.25	21.9	125.5	26.9	3.44	15.2	2.29	21.9		
30	5	60	72.7	30.9	1.84	24.6	4.92	19.8	69.5	30.8	1.79	24.7	5.06	19.8	66.3	30.7	1.73	24.8	5.20	19.8		
		80	92.4	30.0	2.42	21.8	3.64	21.0	89.3	30.0	2.36	21.9	3.73	21.0	86.2	29.9	2.30	22.0	3.81	20.9		
		100	112.0	29.2	2.99	19.0	2.85	22.2	109.0	29.1	2.93	19.1	2.91	22.1	106.0	29.0	2.86	19.3	2.97	22.1		
		120	131.7	28.3	3.57	16.1	2.32	23.4	128.7	28.3	3.50	16.3	2.37	23.3	125.8	28.2	3.43	16.5	2.41	23.2		
	7.5	60	73.3	32.3	1.84	26.0	5.14	22.1	70.0	32.2	1.78	26.1	5.29	22.1	66.6	32.2	1.73	26.3	5.46	22.0		
		80	92.8	31.0	2.43	22.7	3.74	23.1	89.6	31.0	2.36	23.0	3.85	23.0	86.4	31.1	2.29	23.2	3.97	22.9		
		100	112.3	29.8	3.02	19.5	2.90	24.0	109.2	29.9	2.94	19.9	2.98	23.9	106.2	30.0	2.86	20.2	3.07	23.9		
		120	131.8	28.6	3.61	16.3	2.32	25.0	128.9	28.7	3.52	16.7	2.39	24.9	125.9	28.9	3.43	17.1	2.46	24.8		
	10	60	73.9	33.6	1.84	27.3	5.35	24.4	70.4	33.6	1.78	27.5	5.54	24.3	66.9	33.6	1.72	27.7	5.72	24.3		
		80	93.2	32.0	2.44	23.7	3.85	25.1	89.9	32.1	2.37	24.1	3.99	25.0	86.6	32.2	2.29	24.4	4.12	25.0		
		100	112.6	30.5	3.04	20.1	2.94	25.9	109.5	30.7	2.95	20.6	3.05	25.8	106.4	30.9	2.86	21.1	3.16	25.6		
		120	131.9	28.9	3.64	16.5	2.33	26.6	129.0	29.2	3.54	17.1	2.42	26.5	126.1	29.5	3.43	17.8	2.52	26.3		
50	5	60	76.9	41.1	1.88	34.7	6.37	35.7	72.7	40.8	1.81	34.7	6.61	35.7	68.4	40.6	1.74	34.6	6.84	35.7		
		80	96.3	39.5	2.47	31.1	4.67	37.2	92.2	39.3	2.39	31.1	4.82	37.2	88.1	39.1	2.30	31.2	4.97	37.1		
		100	115.6	37.9	3.06	27.4	3.61	38.7	111.7	37.7	2.96	27.6	3.72	38.6	107.8	37.6	2.87	27.8	3.84	38.5		
		120	134.9	36.3	3.65	23.8	2.90	40.2	131.2	36.2	3.54	24.1	2.99	40.1	127.5	36.2	3.44	24.4	3.08	39.9		
	7.5	60	77.7	43.0	1.86	36.6	6.77	38.9	73.2	42.7	1.80	36.5	6.95	38.9	68.7	42.3	1.74	36.4	7.15	38.9		
		80	96.9	41.1	2.46	32.7	4.89	40.1	92.7	40.9	2.38	32.7	5.03	40.0	88.4	40.7	2.30	32.8	5.18	40.0		
		100	116.1	39.1	3.06	28.7	3.75	41.3	112.1	39.1	2.97	29.0	3.86	41.2	108.0	39.0	2.87	29.2	3.98	41.1		
		120	135.4	37.2	3.66	24.7	2.98	42.4	131.5	37.3	3.55	25.2	3.08	42.3	127.7	37.4	3.44	25.6	3.19	42.2		
	10	60	78.5	44.9	1.84	38.6	7.14	42.0	73.8	44.5	1.79	38.4	7.29	42.1	69.1	44.1	1.74	38.2	7.43	42.1		
		80	97.6	42.6	2.45	34.3	5.08	42.9	93.1	42.5	2.38	34.3	5.23	42.9	88.7	42.3	2.30	34.4	5.37	42.9		
		100	116.7	40.4	3.07	30.0	3.85	43.8	112.5	40.4	2.97	30.3	3.99	43.8	108.3	40.4	2.87	30.6	4.13	43.7		
		120	135.8	38.2	3.68	25.6	3.03	44.7	131.9	38.4	3.56	26.3	3.16	44.6	128.0	38.6	3.44	26.9	3.29	44.5		
70	5	60	81.2	51.3	1.92	44.7	7.83	51.5	75.8	50.9	1.83	44.6	8.16	51.6	70.4	50.4	1.74	44.5	8.49	51.7		
		80	100.2	48.9	2.52	40.3	5.69	53.4	95.1	48.6	2.42	40.4	5.91	53.4	90.0	48.3	2.31	40.4	6.13	53.3		
		100	119.2	46.6	3.12	35.9	4.37	55.2	114.4	46.4	3.00	36.1	4.54	55.1	109.5	46.2	2.88	36.4	4.70	55.0		
		120	138.2	44.2	3.72	31.5	3.48	57.0	133.7	44.2	3.59	31.9	3.61	56.8	129.1	44.1	3.45	32.3	3.75	56.7		
	7.5	60	82.1	53.7	1.88	47.3	8.37	55.6	76.5	53.1	1.81	46.9	8.58	55.7	70.8	52.5	1.75	46.5	8.82	55.8		
		80	101.1	51.1	2.49	42.6	6.00	57.1	95.7	50.7	2.40	42.5	6.18	57.1	90.4	50.3	2.31	42.4	6.38	57.1		
		100	120.0	48.5	3.11	37.9	4.57	58.5	115.0	48.3	2.99	38.1	4.73	58.4	109.9	48.1	2.88	38.3	4.90	58.4		
		120	138.9	45.9	3.72	33.2	3.61	59.9	134.2	45.9	3.58	33.6	3.75	59.8	129.5	45.9	3.45	34.1	3.90	59.6		
	10	60	83.1	56.1	1.84	49.8	8.93	59.7	77.2	55.4	1.80	49.2	9.04	59.9	71.3	54.6	1.75	48.6	9.14	60.0		
		80	102.0	53.2	2.47	44.8	6.32	60.8	96.4	52.8	2.39	44.6	6.47	60.8	90.8	52.3	2.31	44.4	6.62	60.8		
		100	120.8	50.4	3.09	39.8	4.77	61.8	115.5	50.2	2.99	40.0	4.93	61.8	110.3	50.0	2.88	40.2	5.09	61.7		
		120	139.6	47.5	3.72	34.8	3.74	62.8	134.7	47.6	3.58	35.4	3.90	62.7	129.8	47.7	3.44	36.0	4.06	62.6		
90	5	60	85.4	61.5	1.99	54.7	9.05	67.4	78.5	59.0	1.88	52.5	9.20	68.3	71.6	56.4	1.77	50.4	9.34	69.2		
		80	104.5	59.4	2.56	50.7	6.79	69.1	97.8	56.7	2.44	48.3	6.80	70.1	91.1	53.9	2.32	46.0	6.80	71.0		
		100	Operation not recommended																			
		120	Operation not recommended																			
	7.5	60	86.2	63.7	2.01	56.8	9.30	72.6	79.0	60.4	1.89	53.9	9.37	73.5	71.8	57.1	1.77	51.0	9.44	74.3		
		80	105.5	61.9	2.58	53.1	7.03	73.8	98.4	58.3	2.45	49.9	6.97	74.7	91.3	54.7	2.33	46.8	6.90	75.6		
		100	124.8	60.1	3.15	49.3	5.59	75.0	117.8	56.2	3.01	45.9	5.47	76.0	110.8	52.4	2.88	42.6	5.33	76.9		
		120	Operation not recommended																			
	10	60	87.1	65.8	2.02	58.9	9.54	77.9	79.5	61.8	1.90	55.3	9.55	78.6	71.9	57.7	1.77	51.7	9.55	79.3		
		80	106.5	64.3	2.59	55.4	7.27	78.6	99.0	59.9	2.46	51.5	7.13	79.4	91.5	55.6	2.33	47.6	7.00	80.2		
		100	125.9	62.7	3.16	51.9	5.82	79.3	118.4	58.1	3.02	47.8	5.62	80.2	111.0	53.4	2.88	43.6	5.43	81.0		
		120	Operation not recommended																			

050 - Performance Data

Cooling Capacity

Source		Load Flow-8 GPM							Load Flow-11.5 GPM							Load Flow-15 GPM						
EST °F	Flow GPM	ELT °F	LLT °F	TC MBTUH	Power kW	HR MBTUH	EER	LST °F	LLT °F	TC MBTUH	Power kW	HR MBTUH	EER	LST °F	LLT °F	TC MBTUH	Power kW	HR MBTUH	EER	LST °F		
30	8	50	35.8	55.2	1.98	61.9	27.9	46.0	38.8	57.0	2.00	63.8	28.6	46.4	41.9	58.8	2.01	65.7	29.3	46.9		
		70	54.6	59.8	2.01	66.6	29.8	47.2	58.0	61.0	2.02	67.8	30.3	47.5	61.5	62.2	2.02	69.1	30.7	47.8		
		90	73.4	64.3	2.03	71.3	31.6	48.4	77.2	64.9	2.04	71.9	31.9	48.5	81.0	65.5	2.04	72.5	32.2	48.7		
		110	92.2	68.9	2.06	75.9	33.4	49.6	96.4	68.9	2.06	75.9	33.5	49.6	100.5	68.9	2.05	75.9	33.6	49.6		
	11.5	50	35.9	54.6	1.90	61.1	28.8	42.1	39.0	56.3	1.92	62.8	29.3	42.5	42.0	57.9	1.94	64.5	29.8	42.8		
		70	55.0	58.1	1.92	64.6	30.3	42.9	58.4	59.1	1.93	65.7	30.7	43.1	61.7	60.2	1.94	66.9	31.0	43.3		
		90	74.2	61.5	1.93	68.1	31.8	43.6	77.8	62.0	1.94	68.6	32.0	43.8	81.4	62.6	1.94	69.2	32.3	43.9		
		110	93.3	64.9	1.95	71.6	33.3	44.4	97.2	64.9	1.95	71.5	33.4	44.4	101.1	64.9	1.94	71.5	33.5	44.4		
	15	50	36.1	54.1	1.82	60.3	29.7	38.3	39.1	55.6	1.85	61.8	30.1	38.5	42.2	57.0	1.87	63.4	30.5	38.7		
		70	55.5	56.4	1.83	62.6	30.9	38.6	58.7	57.3	1.84	63.6	31.1	38.7	62.0	58.3	1.86	64.6	31.4	38.9		
		90	74.9	58.6	1.83	64.9	32.0	38.9	78.3	59.1	1.84	65.4	32.2	39.0	81.8	59.6	1.84	65.9	32.3	39.1		
		110	94.3	60.9	1.84	67.2	33.1	39.2	98.0	60.9	1.84	67.2	33.2	39.2	101.6	60.9	1.83	67.1	33.3	39.2		
50	8	50	36.7	51.5	2.53	60.2	21.7	65.5	39.5	53.5	2.53	62.2	22.4	66.0	42.4	55.5	2.54	64.2	23.1	66.5		
		70	54.6	59.9	2.58	68.7	24.4	67.7	57.9	61.5	2.59	70.4	24.9	68.1	61.3	63.1	2.60	72.0	25.5	68.5		
		90	72.4	68.3	2.64	77.3	26.9	69.9	76.3	69.5	2.65	78.5	27.3	70.2	80.3	70.7	2.65	79.8	27.7	70.6		
		110	90.2	76.7	2.70	85.9	29.4	72.1	94.7	77.5	2.71	86.7	29.6	72.4	99.2	78.3	2.71	87.5	29.8	72.6		
	11.5	50	39.8	51.6	2.43	59.9	21.3	61.9	39.6	53.4	2.44	61.7	21.9	62.2	42.4	55.2	2.45	63.6	22.5	62.6		
		70	58.3	58.9	2.47	67.4	23.9	63.4	58.2	60.3	2.48	68.8	24.4	63.7	61.5	61.7	2.48	70.2	24.9	64.0		
		90	76.8	66.3	2.51	74.8	26.4	64.9	76.8	67.3	2.51	75.8	26.8	65.1	80.6	68.3	2.52	76.9	27.1	65.4		
		110	95.3	73.6	2.55	82.3	28.9	66.5	95.4	74.2	2.55	82.9	29.1	66.6	99.7	74.8	2.55	83.5	29.3	66.7		
	15	50	42.9	51.7	2.33	59.7	23.5	58.2	39.6	53.3	2.35	61.3	24.0	58.4	42.5	54.9	2.36	63.0	24.5	58.7		
		70	62.0	58.0	2.35	66.0	25.8	59.1	58.4	59.2	2.36	67.2	26.2	59.2	61.7	60.4	2.37	68.5	26.5	59.4		
		90	81.2	64.2	2.37	72.3	28.0	59.9	77.2	65.0	2.38	73.1	28.2	60.1	80.9	65.9	2.38	74.0	28.5	60.2		
		110	100.3	70.5	2.39	78.6	30.2	60.8	96.0	70.9	2.39	79.1	30.3	60.9	100.2	71.4	2.40	79.5	30.5	60.9		
70	8	50	37.7	47.9	3.07	58.4	15.6	85.0	40.2	50.1	3.07	60.5	16.3	85.6	42.8	52.2	3.07	62.7	17.0	86.2		
		70	54.5	60.1	3.16	70.9	19.0	88.3	57.9	62.1	3.17	72.9	19.6	88.8	61.2	64.0	3.17	74.9	20.2	89.3		
		90	71.4	72.3	3.25	83.4	22.2	91.5	75.5	74.1	3.26	85.2	22.7	92.0	79.6	75.9	3.27	87.0	23.2	92.4		
		110	Operation not recommended																			
	11.5	50	37.5	48.6	2.96	58.7	16.4	81.6	40.1	50.6	2.96	60.6	17.1	82.0	42.8	52.5	2.96	62.6	17.7	82.4		
		70	54.6	59.8	3.02	70.1	19.8	83.9	57.9	61.5	3.02	71.8	20.4	84.3	61.3	63.3	3.03	73.6	20.9	84.6		
		90	71.7	71.0	3.08	81.5	23.1	86.2	75.8	72.5	3.09	83.1	23.5	86.5	79.8	74.0	3.10	84.6	23.9	86.9		
		110	Operation not recommended																			
	15	50	37.3	49.3	2.84	59.0	17.4	78.1	40.0	51.1	2.85	60.8	17.9	78.4	42.7	52.8	2.85	62.5	18.5	78.6		
		70	54.7	59.5	2.87	69.3	20.7	79.5	58.0	61.0	2.88	70.8	21.2	79.7	61.4	62.5	2.89	72.3	21.6	79.9		
		90	72.0	69.8	2.91	79.7	24.0	81.0	76.1	71.0	2.92	80.9	24.3	81.1	80.1	72.1	2.92	82.1	24.7	81.3		
		110	89.4	80.0	2.94	90.0	27.2	82.4	94.1	80.9	2.95	91.0	27.4	82.5	98.8	81.8	2.96	91.9	27.6	82.6		
90	8	50	38.9	43.0	3.93	56.4	11.8	104.5	41.3	44.7	3.94	58.1	12.2	105.0	43.6	46.4	3.95	59.9	12.7	105.4		
		70	56.0	54.5	4.02	68.2	14.5	107.6	59.0	56.2	4.04	70.0	14.9	108.0	62.0	58.0	4.05	71.8	15.4	108.5		
		90	73.0	66.0	4.12	80.0	17.1	110.6	76.7	67.8	4.13	81.9	17.5	111.1	80.4	69.5	4.15	83.7	17.9	111.6		
		110	Operation not recommended																			
	11.5	50	38.8	43.6	3.81	56.6	11.5	101.2	41.2	45.2	3.81	58.2	11.8	101.5	43.6	46.8	3.82	59.8	12.2	101.8		
		70	55.9	54.7	3.87	67.9	14.1	103.4	59.0	56.3	3.88	69.6	14.5	103.8	62.0	57.9	3.89	71.2	14.9	104.1		
		90	73.0	65.9	3.93	79.3	16.8	105.7	76.8	67.5	3.95	81.0	17.1	106.1	80.5	69.1	3.96	82.7	17.4	106.4		
		110	Operation not recommended																			
	15	50	38.6	44.2	3.68	56.8	13.0	97.8	41.1	45.7	3.69	58.2	13.4	98.0	43.5	47.1	3.69	59.7	13.8	98.2		
		70	55.8	55.0	3.72	67.7	15.9	99.3	58.9	56.5	3.72	69.2	16.3	99.5	62.0	57.9	3.73	70.7	16.7	99.7		
		90	73.0	65.8	3.75	78.6	18.7	100.8	76.8	67.3	3.76	80.1	19.1	101.0	80.6	68.7	3.77	81.6	19.4	101.2		
		110	Operation not recommended																			
110	8	50	40.2	38.0	4.79	54.3	7.9	124.0	42.3	39.3	4.81	55.7	8.2	124.4	44.4	40.6	4.82	57.1	8.4	124.7		
		70	57.4	48.8	4.89	65.5	10.0	126.9	60.1	50.4	4.91	67.1	10.3	127.3	62.9	51.9	4.93	68.7	10.5	127.7		
		90	Operation not recommended																			
		110	Operation not recommended																			
	11.5	50	40.1	38.6	4.66	54.4	8.3	120.8	42.2	39.8	4.67	55.7	8.5	121.0	44.4	41.0	4.68	57.0	8.8	121.3		
		70	57.2	49.7	4.72	65.8	10.5	123.0	60.0	51.2	4.74	67.3	10.8	123.3	62.8	52.6	4.75	68.9	11.1	123.6		
		90	Operation not recommended																			
		110	Operation not recommended																			
	15	50	39.9	39.1	4.52	54.5	8.7	117.5	42.1	40.3	4.53	55.7	8.9	117.7	44.3	41.4	4.53	56.9	9.1	117.8		
		70	57.0	50.5	4.56	66.1	11.1	119.1	59.8	51.9	4.57	67.5	11.4	119.3	62.7	53.4	4.58	69.0	11.7	119.5		
		90	Operation not recommended																			
		110	Operation not recommended																			

050 - Performance Data cont.

Heating Capacity

Source		Load Flow-8 GPM							Load Flow-11.5 GPM							Load Flow-15 GPM						
EST °F	Flow GPM	ELT °F	LLT °F	HC MBTUH	Power kW	HE MBTUH	COP	LST °F	LLT °F	HC MBTUH	Power kW	HE MBTUH	COP	LST °F	LLT °F	HC MBTUH	Power kW	HE MBTUH	COP	LST °F		
25	11.5	60	Operation not recommended																			
		80	Operation not recommended																			
		100	Operation not recommended																			
		120	Operation not recommended																			
	15	60	71.3	43.9	2.50	35.4	5.15	20.1	67.9	44.0	2.50	35.4	5.16	20.1	66.0	44.0	2.49	35.5	5.18	20.1		
80		91.0	42.6	3.41	31.0	3.66	20.7	87.6	42.6	3.37	31.1	3.71	20.7	85.9	42.6	3.33	31.3	3.75	20.7			
100		110.6	41.3	4.32	26.6	2.80	21.3	107.4	41.3	4.25	26.8	2.85	21.3	105.7	41.3	4.17	27.0	2.90	21.3			
120		130.3	40.0	5.23	22.2	2.24	22.0	127.2	40.0	5.12	22.5	2.29	21.9	125.5	39.9	5.01	22.8	2.33	21.9			
30	8	60	71.8	45.7	2.36	37.6	5.67	20.3	69.0	45.8	2.43	37.5	5.53	20.3	66.3	45.8	2.49	37.3	5.39	20.4		
		80	91.4	44.4	3.31	33.1	3.92	21.5	88.8	44.4	3.33	33.0	3.91	21.5	86.1	44.4	3.34	33.0	3.89	21.5		
		100	111.1	43.0	4.27	28.5	2.96	22.7	108.5	43.0	4.23	28.6	2.98	22.6	105.9	43.0	4.19	28.7	3.01	22.6		
		120	130.7	41.7	5.22	23.9	2.34	23.8	128.2	41.7	5.13	24.1	2.38	23.8	125.7	41.6	5.04	24.4	2.42	23.7		
	11.5	60	72.2	47.2	2.50	38.6	5.53	22.4	69.3	47.2	2.49	38.7	5.56	22.4	66.5	47.3	2.48	38.8	5.59	22.4		
		80	91.7	45.5	3.41	33.9	3.92	23.4	89.0	45.6	3.37	34.1	3.96	23.3	86.3	45.6	3.33	34.2	4.01	23.3		
		100	111.3	43.9	4.31	29.2	2.98	24.3	108.7	43.9	4.25	29.4	3.03	24.2	106.0	43.9	4.18	29.6	3.08	24.2		
		120	130.9	42.3	5.22	24.5	2.37	25.2	128.4	42.3	5.13	24.8	2.42	25.1	125.8	42.2	5.03	25.0	2.46	25.1		
	15	60	72.5	48.6	2.64	39.6	5.39	24.6	69.6	48.7	2.56	40.0	5.59	24.5	66.7	48.8	2.47	40.4	5.79	24.5		
		80	92.0	46.7	3.50	34.8	3.91	25.2	89.2	46.8	3.41	35.1	4.02	25.2	86.4	46.8	3.32	35.5	4.13	25.1		
		100	111.5	44.8	4.36	29.9	3.01	25.9	108.9	44.8	4.27	30.2	3.08	25.8	106.2	44.8	4.17	30.6	3.15	25.8		
		120	131.1	42.9	5.22	25.1	2.41	26.6	128.5	42.9	5.12	25.4	2.45	26.5	125.9	42.8	5.02	25.7	2.50	26.5		
50	8	60	75.1	58.8	2.56	50.0	6.65	37.1	71.6	58.6	2.54	50.0	6.72	37.1	68.0	58.5	2.52	49.9	6.80	37.1		
		80	94.5	56.3	3.47	44.4	4.71	38.5	91.1	56.2	3.42	44.6	4.80	38.5	87.7	56.2	3.36	44.7	4.88	38.5		
		100	113.9	53.9	4.39	38.9	3.58	40.0	110.6	53.8	4.30	39.2	3.66	39.9	107.4	53.8	4.21	39.4	3.74	39.8		
		120	133.2	51.4	5.30	33.3	2.83	41.4	130.2	51.4	5.18	33.7	2.91	41.3	127.1	51.5	5.06	34.2	2.98	41.2		
	11.5	60	75.7	61.0	2.64	52.0	6.78	39.8	72.0	60.8	2.58	52.0	6.91	39.9	68.3	60.5	2.51	51.9	7.06	39.9		
		80	95.0	58.1	3.53	46.1	4.83	41.0	91.5	57.9	3.44	46.2	4.93	41.0	87.9	57.8	3.36	46.3	5.04	41.0		
		100	114.2	55.2	4.41	40.2	3.67	42.1	110.9	55.1	4.31	40.4	3.75	42.1	107.6	55.0	4.21	40.6	3.83	42.0		
		120	133.5	52.4	5.30	34.3	2.89	43.3	130.3	52.3	5.18	34.6	2.96	43.2	127.2	52.3	5.06	35.0	3.03	43.1		
	15	60	76.3	63.3	2.72	54.0	6.79	42.6	72.4	62.9	2.61	54.0	7.03	42.6	68.6	62.5	2.51	53.9	7.27	42.6		
		80	95.4	59.9	3.58	47.7	4.89	43.4	91.8	59.6	3.47	47.8	5.03	43.4	88.2	59.4	3.36	47.9	5.17	43.4		
		100	114.6	56.6	4.44	41.5	3.72	44.3	111.2	56.4	4.32	41.7	3.82	44.3	107.7	56.2	4.20	41.9	3.91	44.2		
		120	133.7	53.3	5.30	35.2	2.94	45.2	130.5	53.2	5.18	35.5	3.01	45.1	127.3	53.1	5.05	35.8	3.07	45.1		
70	8	60	78.5	71.8	2.76	62.4	7.62	53.9	74.1	71.5	2.65	62.5	7.92	53.9	69.8	71.2	2.54	62.5	8.21	53.9		
		80	97.6	68.2	3.63	55.8	5.50	55.6	93.5	68.1	3.51	56.1	5.69	55.5	89.3	67.9	3.39	56.3	5.87	55.5		
		100	116.7	64.7	4.51	49.3	4.20	57.3	112.8	64.6	4.37	49.7	4.34	57.2	108.9	64.6	4.23	50.2	4.47	57.1		
		120	135.7	61.1	5.38	42.7	3.33	59.0	132.1	61.2	5.23	43.4	3.43	58.8	128.4	61.3	5.08	44.0	3.54	58.7		
	11.5	60	79.3	74.9	2.78	65.4	7.90	57.3	74.7	74.3	2.66	65.2	8.18	57.3	70.1	73.7	2.55	65.0	8.48	57.3		
		80	98.2	70.7	3.64	58.3	5.69	58.6	93.9	70.3	3.52	58.3	5.86	58.6	89.6	69.9	3.39	58.3	6.04	58.6		
		100	117.2	66.6	4.51	51.2	4.32	60.0	113.1	66.3	4.37	51.4	4.44	59.9	109.1	66.1	4.24	51.6	4.57	59.9		
		120	136.1	62.4	5.38	44.0	3.40	61.4	132.3	62.4	5.23	44.5	3.49	61.3	128.6	62.3	5.08	45.0	3.59	61.2		
	15	60	80.1	77.9	2.79	68.4	8.18	60.6	75.3	77.1	2.67	67.9	8.47	60.7	70.5	76.2	2.55	67.5	8.76	60.7		
		80	98.9	73.2	3.65	60.7	5.87	61.7	94.4	72.5	3.52	60.5	6.04	61.7	89.9	71.9	3.39	60.3	6.21	61.7		
		100	117.6	68.4	4.52	53.0	4.44	62.7	113.5	68.0	4.38	53.1	4.56	62.7	109.3	67.6	4.24	53.1	4.68	62.7		
		120	136.4	63.7	5.38	45.3	3.47	63.8	132.6	63.5	5.23	45.7	3.56	63.7	128.7	63.3	5.08	46.0	3.65	63.7		
90	8	60	81.9	84.9	2.85	75.2	8.73	70.6	76.5	82.8	3.51	70.8	7.21	71.7	71.1	80.7	4.16	66.5	5.68	72.9		
		80	100.6	80.1	3.71	67.4	6.32	72.6	95.6	78.7	4.09	64.8	5.70	73.3	90.6	77.4	4.47	62.2	5.08	74.0		
		100	119.4	75.2	4.58	59.6	4.82	74.6	114.8	74.7	4.68	58.7	4.68	74.9	110.2	74.1	4.77	57.8	4.55	75.1		
		120	Operation not recommended																			
	11.5	60	82.3	86.6	2.86	76.9	8.89	74.9	76.8	84.1	3.12	73.5	7.91	75.6	71.2	81.6	3.38	70.1	7.08	76.4		
		80	101.1	81.8	3.72	69.0	6.43	76.5	95.9	80.2	3.84	67.1	6.12	76.9	90.8	78.6	3.95	65.1	5.83	77.3		
		100	119.8	76.9	4.59	61.2	4.91	78.0	115.1	76.2	4.56	60.7	4.90	78.1	110.4	75.5	4.52	60.1	4.90	78.3		
		120	Operation not recommended																			
	15	60	82.8	88.3	2.86	78.5	9.05	79.2	77.0	85.4	2.73	76.1	9.19	79.5	71.3	82.5	2.59	73.7	9.33	79.9		
		80	101.5	83.4	3.73	70.7	6.55	80.3	96.2	81.6	3.58	69.3	6.68	80.5	91.0	79.7	3.43	68.0	6.81	80.7		
		100	120.2	78.6	4.61	62.8	5.00	81.4	115.4	77.7	4.44	62.6	5.14	81.4	110.6	76.9	4.26	62.3	5.28	81.4		
		120	Operation not recommended																			

060 - Performance Data

Cooling Capacity

Source		Load Flow-9 GPM							Load Flow-13.5 GPM							Load Flow-18 GPM						
EST °F	Flow GPM	ELT °F	LLT °F	TC MBTUH	Power kW	HR MBTUH	EER	LST °F	LLT °F	TC MBTUH	Power kW	HR MBTUH	EER	LST °F	LLT °F	TC MBTUH	Power kW	HR MBTUH	EER	LST °F		
30	9	50	36.0	61.1	2.23	68.7	27.4	45.7	39.1	64.5	2.25	72.1	28.7	46.5	42.2	67.8	2.26	75.5	30.0	47.3		
		70	54.4	68.1	2.26	75.9	30.1	47.4	58.0	70.6	2.28	78.4	31.0	48.0	61.6	73.1	2.29	80.9	32.0	48.5		
		90	72.8	75.2	2.30	83.0	32.7	49.0	76.9	76.8	2.31	84.7	33.3	49.4	81.0	78.5	2.31	86.4	33.9	49.8		
		110	91.2	82.2	2.33	90.2	35.3	50.7	95.8	83.0	2.34	91.0	35.5	50.8	100.4	83.8	2.34	91.8	35.8	51.0		
	13.5	50	36.1	60.5	2.14	67.8	28.3	41.7	39.2	64.0	2.15	71.3	29.7	42.3	42.3	67.5	2.17	74.8	31.2	42.9		
		70	54.8	66.1	2.16	73.5	30.6	42.8	58.4	68.6	2.17	76.0	31.7	43.2	61.9	71.1	2.18	78.5	32.7	43.6		
		90	73.6	71.8	2.18	79.2	33.0	43.8	77.5	73.3	2.18	80.7	33.6	44.1	81.4	74.8	2.19	82.2	34.2	44.4		
		110	92.3	77.4	2.20	84.9	35.3	44.9	96.6	77.9	2.20	85.4	35.4	45.0	101.0	78.4	2.20	85.9	35.6	45.1		
	18	50	36.3	59.9	2.05	66.9	29.2	37.7	39.3	63.5	2.06	70.5	30.8	38.1	42.3	67.1	2.07	74.2	32.4	38.5		
		70	55.3	64.1	2.05	71.1	31.2	38.1	58.7	66.6	2.06	73.6	32.3	38.4	62.1	69.1	2.07	76.1	33.4	38.7		
		90	74.3	68.4	2.06	75.4	33.2	38.6	78.1	69.7	2.06	76.7	33.8	38.8	81.9	71.0	2.06	78.1	34.4	38.9		
		110	93.4	72.6	2.06	79.6	35.2	39.1	97.5	72.8	2.06	79.8	35.3	39.1	101.6	73.0	2.06	80.0	35.4	39.2		
50	9	50	36.8	57.4	2.86	67.2	21.4	65.4	39.8	60.2	2.87	70.0	22.4	66.0	42.8	63.0	2.88	72.8	23.3	66.7		
		70	54.3	68.3	2.93	78.3	24.6	67.9	58.0	70.6	2.94	80.7	25.3	68.5	61.6	72.9	2.95	83.0	26.0	69.0		
		90	71.8	79.3	3.00	89.5	27.6	70.5	76.2	81.1	3.01	91.3	28.1	70.9	80.5	82.8	3.02	93.2	28.6	71.3		
		110	89.3	90.2	3.07	100.7	30.5	73.1	94.4	91.5	3.08	102.0	30.8	73.4	99.4	92.8	3.10	103.3	31.1	73.7		
	13.5	50	36.9	57.3	2.75	66.6	20.9	61.5	39.8	60.2	2.75	69.6	21.9	62.0	42.8	63.1	2.76	72.5	22.9	62.5		
		70	54.7	66.9	2.79	76.4	24.0	63.2	58.2	69.2	2.80	78.8	24.7	63.6	61.8	71.5	2.81	81.1	25.5	64.0		
		90	72.5	76.6	2.83	86.2	27.0	65.0	76.7	78.2	2.84	87.9	27.5	65.3	80.8	79.9	2.85	89.7	28.0	65.6		
		110	90.3	86.2	2.88	96.0	30.0	66.8	95.1	87.3	2.89	97.1	30.2	67.0	99.9	88.3	2.90	98.2	30.5	67.2		
	18	50	36.9	57.2	2.63	66.1	23.1	57.6	39.8	60.2	2.64	69.2	24.3	57.9	42.8	63.2	2.64	72.2	25.4	58.3		
		70	55.0	65.5	2.65	74.5	25.9	58.5	58.5	67.8	2.66	76.9	26.8	58.8	62.0	70.1	2.66	79.2	27.6	59.1		
		90	73.1	73.9	2.67	83.0	28.7	59.5	77.1	75.4	2.68	84.6	29.2	59.7	81.2	77.0	2.68	86.2	29.8	59.9		
		110	91.2	82.2	2.69	91.4	31.5	60.5	95.8	83.1	2.70	92.2	31.7	60.6	100.4	83.9	2.71	93.1	31.9	60.7		
70	9	50	37.7	53.7	3.49	65.6	15.4	85.0	40.5	56.0	3.50	67.9	16.0	85.6	43.3	58.2	3.50	70.1	16.6	86.1		
		70	54.3	68.5	3.60	80.8	19.1	88.5	58.0	70.6	3.61	82.9	19.6	89.0	61.7	72.7	3.62	85.0	20.1	89.5		
		90	70.9	83.4	3.70	96.0	22.5	92.0	75.5	85.3	3.72	98.0	22.9	92.4	80.0	87.2	3.73	99.9	23.4	92.9		
		110	Operation not recommended																			
	13.5	50	37.6	54.1	3.35	65.5	16.1	81.3	40.4	56.4	3.35	67.8	16.8	81.7	43.3	58.8	3.36	70.2	17.5	82.1		
		70	54.5	67.7	3.42	79.4	19.8	83.7	58.1	69.8	3.43	81.5	20.4	84.1	61.8	71.9	3.44	83.6	20.9	84.5		
		90	71.4	81.4	3.49	93.3	23.3	86.2	75.8	83.2	3.50	95.2	23.7	86.5	80.3	85.1	3.52	97.1	24.2	86.8		
		110	Operation not recommended																			
	18	50	37.5	54.4	3.21	65.4	16.9	77.5	40.4	56.9	3.21	67.8	17.7	77.8	43.2	59.3	3.21	70.3	18.5	78.0		
		70	54.7	66.9	3.24	77.9	20.6	78.9	58.3	69.0	3.25	80.1	21.2	79.2	61.9	71.1	3.26	82.2	21.8	79.4		
		90	71.8	79.3	3.28	90.5	24.2	80.4	76.2	81.2	3.29	92.4	24.7	80.6	80.5	83.0	3.30	94.2	25.1	80.8		
		110	89.0	91.8	3.31	103.1	27.7	81.8	94.1	93.3	3.33	104.7	28.0	82.0	99.1	94.8	3.35	106.2	28.3	82.2		
90	9	50	39.1	47.6	4.48	62.8	11.5	104.4	41.6	49.5	4.48	64.7	11.9	104.8	44.1	51.4	4.49	66.7	12.4	105.3		
		70	55.8	61.8	4.58	77.4	14.5	107.7	59.2	63.7	4.59	79.4	14.9	108.2	62.5	65.6	4.61	81.4	15.3	108.6		
		90	72.6	76.1	4.68	92.0	17.3	111.1	76.7	78.0	4.70	94.0	17.7	111.5	80.8	79.9	4.73	96.1	18.0	112.0		
		110	Operation not recommended																			
	13.5	50	39.0	48.0	4.32	62.7	11.1	100.8	41.5	49.9	4.32	64.6	11.5	101.1	44.1	51.9	4.33	66.6	12.0	101.4		
		70	55.9	61.6	4.38	76.5	14.1	103.2	59.2	63.6	4.40	78.6	14.5	103.5	62.5	65.5	4.41	80.6	14.9	103.9		
		90	72.8	75.2	4.45	90.4	16.9	105.6	76.8	77.2	4.47	92.5	17.3	106.0	80.9	79.2	4.49	94.6	17.6	106.3		
		110	Operation not recommended																			
	18	50	38.9	48.4	4.16	62.5	12.6	97.2	41.5	50.4	4.16	64.5	13.1	97.4	44.0	52.4	4.16	66.5	13.7	97.6		
		70	55.9	61.4	4.19	75.7	15.7	98.7	59.2	63.4	4.20	77.7	16.2	98.9	62.5	65.5	4.21	79.8	16.7	99.1		
		90	73.0	74.4	4.22	88.8	18.8	100.2	77.0	76.5	4.24	90.9	19.3	100.4	81.0	78.6	4.25	93.1	19.7	100.7		
		110	Operation not recommended																			
110	9	50	40.5	41.4	5.46	60.0	7.6	123.8	42.7	43.0	5.47	61.6	7.9	124.1	44.9	44.5	5.48	63.2	8.1	124.5		
		70	57.4	55.1	5.55	74.0	9.9	127.0	60.3	56.8	5.58	75.9	10.2	127.4	63.3	58.6	5.61	77.7	10.4	127.8		
		90	Operation not recommended																			
		110	Operation not recommended																			
	13.5	50	40.4	41.9	5.29	59.9	7.9	120.3	42.6	43.4	5.29	61.5	8.2	120.6	44.9	45.0	5.30	63.0	8.5	120.8		
		70	57.3	55.5	5.35	73.7	10.4	122.7	60.3	57.3	5.36	75.6	10.7	123.0	63.2	59.2	5.38	77.5	11.0	123.3		
		90	Operation not recommended																			
		110	Operation not recommended																			
	18	50	40.3	42.3	5.11	59.7	8.3	116.8	42.6	43.9	5.11	61.3	8.6	117.0	44.8	45.4	5.11	62.8	8.9	117.2		
		70	57.2	55.9	5.14	73.4	10.9	118.4	60.2	57.8	5.15	75.4	11.2	118.6	63.2	59.8	5.16	77.4	11.6	118.9		
		90	Operation not recommended																			
		110	Operation not recommended																			

060 - Performance Data cont.

Heating Capacity

Source		Load Flow-9 GPM							Load Flow-13.5 GPM							Load Flow-18 GPM																							
EST °F	Flow GPM	ELT °F	LLT °F	HC MBTUH	Power kW	HE MBTUH	COP	LST °F	LLT °F	HC MBTUH	Power kW	HE MBTUH	COP	LST °F	LLT °F	HC MBTUH	Power kW	HE MBTUH	COP	LST °F																			
25	13.5	60	Operation not recommended																																				
		80																																					
		100																																					
		120																																					
	18	60	71.1	48.3	2.93	38.3	4.83	20.6	67.4	48.6	2.86	38.8	4.98	20.6	65.6	48.9	2.79	39.4	5.14	20.5																			
		80	90.8	47.3	3.93	33.9	3.53	21.1	87.3	47.6	3.85	34.4	3.62	21.1	85.5	47.8	3.76	35.0	3.72	21.0																			
		100	110.6	46.3	4.93	29.5	2.75	21.6	107.1	46.5	4.83	30.0	2.82	21.6	105.4	46.8	4.74	30.6	2.89	21.5																			
		120	130.4	45.3	5.93	25.1	2.24	22.1	126.9	45.5	5.82	25.6	2.29	22.1	125.2	45.7	5.71	26.2	2.35	22.0																			
30	9	60	71.5	50.1	2.94	40.1	4.99	20.8	68.7	50.5	2.87	40.7	5.17	20.7	65.8	50.9	2.79	41.4	5.35	20.5																			
		80	91.3	49.3	3.95	35.9	3.66	21.8	88.5	49.7	3.86	36.5	3.77	21.6	85.7	50.0	3.77	37.1	3.89	21.5																			
		100	111.1	48.6	4.95	31.7	2.87	22.7	108.4	48.8	4.85	32.3	2.95	22.6	105.6	49.0	4.74	32.8	3.03	22.5																			
		120	131.0	47.8	5.96	27.5	2.35	23.7	128.2	48.0	5.84	28.0	2.41	23.6	125.5	48.1	5.72	28.6	2.46	23.5																			
	13.5	60	71.9	52.1	3.0	42.0	5.17	22.9	68.9	51.8	2.87	42.0	5.29	22.9	65.9	51.6	2.8	42.0	5.41	22.8																			
		80	91.7	50.9	4.0	37.4	3.77	23.7	88.7	50.8	3.86	37.6	3.86	23.6	85.8	50.7	3.8	37.8	3.95	23.5																			
		100	111.4	49.7	5.0	32.8	2.94	24.4	108.6	49.8	4.84	33.2	3.01	24.3	105.7	49.8	4.7	33.7	3.08	24.3																			
		120	131.1	48.6	6.0	28.2	2.39	25.2	128.4	48.8	5.83	28.9	2.45	25.1	125.6	49.0	5.7	29.5	2.51	25.0																			
	18	60	72.4	54.1	2.97	44.0	5.34	25.0	69.2	53.2	2.88	43.3	5.41	25.0	66.0	52.2	2.79	42.7	5.48	25.1																			
		80	92.0	52.5	3.96	39.0	3.88	25.5	89.0	52.0	3.86	38.8	3.95	25.6	85.9	51.4	3.76	38.6	4.01	25.6																			
		100	111.7	50.9	4.96	34.0	3.01	26.1	108.7	50.8	4.84	34.2	3.07	26.1	105.8	50.6	4.72	34.5	3.14	26.1																			
		120	131.3	49.3	5.95	29.0	2.43	26.7	128.5	49.6	5.82	29.7	2.50	26.6	125.7	49.8	5.69	30.4	2.56	26.5																			
	50	9	60	75.1	66.0	3.0	55.7	6.34	37.2	71.4	66.2	2.92	56.2	6.62	37.1	67.6	66.3	2.8	56.7	6.90	37.0																		
			80	94.6	63.9	4.0	50.2	4.66	38.5	91.0	64.1	3.89	50.8	4.83	38.4	87.4	64.3	3.8	51.4	4.99	38.2																		
			100	114.1	61.7	5.0	44.7	3.63	39.8	110.6	62.0	4.86	45.4	3.74	39.6	107.1	62.3	4.7	46.1	3.86	39.4																		
			120	133.7	59.6	6.0	39.3	2.93	41.0	130.3	60.0	5.83	40.1	3.02	40.8	126.9	60.3	5.7	40.9	3.11	40.6																		
13.5		60	75.8	68.8	3.1	58.4	6.61	40.1	71.8	68.5	2.93	58.5	6.84	40.1	67.8	68.2	2.8	58.5	7.09	40.0																			
		80	95.2	66.2	4.0	52.5	4.81	41.1	91.4	66.1	3.90	52.8	4.96	41.0	87.6	66.1	3.8	53.2	5.13	41.0																			
		100	114.6	63.7	5.0	46.6	3.72	42.1	111.0	63.8	4.87	47.2	3.84	42.0	107.3	64.0	4.7	47.8	3.96	41.9																			
		120	134.0	61.1	6.0	40.6	2.98	43.1	130.5	61.5	5.85	41.5	3.08	42.9	127.1	61.9	5.7	42.4	3.18	42.8																			
18		60	76.4	71.6	3.1	61.1	6.79	43.0	72.2	70.8	2.95	60.7	7.01	43.0	68.0	70.0	2.8	60.4	7.24	43.1																			
		80	95.7	68.6	4.1	54.7	4.93	43.7	91.7	68.2	3.92	54.8	5.09	43.7	87.8	67.8	3.8	54.9	5.25	43.7																			
		100	115.0	65.6	5.1	48.4	3.79	44.5	111.3	65.6	4.89	48.9	3.92	44.4	107.5	65.6	4.7	49.4	4.06	44.3																			
		120	134.3	62.6	6.0	42.0	3.03	45.2	130.8	63.0	5.87	43.0	3.15	45.1	127.3	63.4	5.7	44.0	3.26	45.0																			
70		9	60	78.8	81.9	3.12	71.3	7.69	53.7	74.1	81.8	2.98	71.6	8.07	53.6	69.4	81.7	2.83	72.0	8.46	53.5																		
			80	98.0	78.4	4.06	64.5	5.65	55.2	93.5	78.5	3.92	65.1	5.88	55.1	89.0	78.6	3.78	65.7	6.10	54.9																		
			100	117.2	74.9	5.01	57.8	4.38	56.8	112.9	75.2	4.87	58.6	4.54	56.6	108.7	75.6	4.72	59.4	4.69	56.4																		
			120	136.4	71.4	5.95	51.1	3.52	58.3	132.3	72.0	5.81	52.1	3.63	58.1	128.3	72.5	5.67	53.1	3.75	57.8																		
	13.5	60	79.6	85.5	3.1	74.8	7.97	57.4	74.6	85.1	3.00	74.9	8.33	57.3	69.7	84.8	2.8	75.0	8.73	57.3																			
		80	98.7	81.6	4.1	67.5	5.81	58.6	94.0	81.5	3.95	68.0	6.04	58.5	89.3	81.4	3.8	68.5	6.29	58.4																			
		100	117.8	77.6	5.1	60.3	4.48	59.8	113.4	77.8	4.91	61.1	4.65	59.6	108.9	78.1	4.7	61.9	4.83	59.5																			
		120	136.9	73.7	6.0	53.0	3.57	61.0	132.7	74.2	5.86	54.2	3.71	60.8	128.6	74.8	5.7	55.4	3.86	60.6																			
	18	60	80.4	89.1	3.17	78.3	8.24	61.0	75.2	88.5	3.02	78.2	8.62	61.0	70.1	87.8	2.86	78.0	8.99	61.1																			
		80	99.4	84.7	4.16	70.5	5.97	61.9	94.5	84.5	3.98	70.9	6.23	61.9	89.6	84.2	3.80	71.2	6.49	61.8																			
		100	118.4	80.3	5.14	62.7	4.57	62.8	113.8	80.5	4.95	63.6	4.77	62.7	109.2	80.6	4.75	64.4	4.98	62.6																			
		120	137.4	75.9	6.13	55.0	3.63	63.7	133.1	76.5	5.91	56.3	3.80	63.6	128.8	77.0	5.69	57.6	3.96	63.4																			
	90	9	60	82.4	97.7	3.26	86.6	8.78	70.2	76.5	95.2	3.09	84.7	9.04	70.6	70.6	92.7	2.92	82.7	9.30	71.0																		
			80	101.4	93.2	4.25	78.7	6.42	72.0	95.9	91.9	4.06	78.0	6.65	72.1	90.4	90.5	3.86	77.4	6.87	72.3																		
			100	Operation not recommended																																			
			120																																				
13.5		60	82.8																				99.7	3.3	88.4	8.89	74.9	76.8	96.7	3.11	86.1	9.12	75.3	70.7	93.7	2.9	83.7	9.37	75.7
		80	101.8																				95.3	4.3	80.6	6.52	76.3	96.2	93.5	4.08	79.6	6.72	76.4	90.5	91.8	3.9	78.6	6.94	76.6
		100	120.8	90.9	5.3	72.8	5.04	77.6	115.6	90.4	5.05	73.1	5.24	77.5	110.3	89.9	4.8	73.4	5.46	77.5																			
		120	Operation not recommended																																				
18		60																				83.3	101.6	3.31	90.3	8.99	79.7	77.1	98.2	3.13	87.5	9.22	80.0	70.8	94.7	2.94	84.7	9.44	80.3
		80																				102.3	97.3	4.31	82.6	6.61	80.5	96.5	95.2	4.10	81.2	6.81	80.7	90.7	93.1	3.89	79.8	7.00	80.9
		100																				121.3	93.0	5.31	74.9	5.13	81.4	115.9	92.2	5.08	74.9	5.33	81.4	110.5	91.4	4.85	74.9	5.53	81.4
		120	Operation not recommended																																				

075 - Performance Data

Cooling Capacity

Source		Load Flow-10 GPM							Load Flow-14.5 GPM							Load Flow-19 GPM						
EST °F	Flow GPM	ELT °F	LLT °F	TC MBTUH	Power kW	HR MBTUH	EER	LST °F	LLT °F	TC MBTUH	Power kW	HR MBTUH	EER	LST °F	LLT °F	TC MBTUH	Power kW	HR MBTUH	EER	LST °F		
30	10	50	34.7	74.0	3.14	84.7	23.6	47.5	37.9	77.8	3.19	88.7	24.4	48.3	41.1	81.6	3.24	92.7	25.2	49.1		
		70	52.4	85.1	3.29	96.4	25.9	49.9	56.3	88.0	3.34	99.3	26.3	50.5	60.2	90.8	3.38	102.3	26.8	51.1		
		90	70.2	96.3	3.45	108.0	27.9	52.3	74.7	98.1	3.49	110.0	28.1	52.7	79.2	99.9	3.53	112.0	28.3	53.1		
		110	87.9	107.4	3.60	119.7	29.8	54.7	93.0	108.3	3.64	120.7	29.8	54.9	98.2	109.1	3.67	121.6	29.7	55.1		
	14.5	50	34.7	74.1	3.01	84.4	24.6	43.3	37.9	77.8	3.05	88.2	25.5	43.9	41.2	81.4	3.09	91.9	26.3	44.5		
		70	52.9	83.1	3.12	93.8	26.6	44.9	56.6	85.8	3.16	96.6	27.2	45.3	60.4	88.5	3.20	99.4	27.7	45.8		
		90	71.0	92.2	3.24	103.2	28.5	46.5	75.3	93.8	3.27	105.0	28.7	46.8	79.6	95.5	3.30	106.8	28.9	47.1		
		110	89.1	101.2	3.35	112.6	30.2	48.1	94.0	101.9	3.38	113.4	30.2	48.2	98.9	102.6	3.41	114.2	30.1	48.3		
	19	50	34.7	74.2	2.88	84.0	25.8	39.1	37.9	77.7	2.91	87.6	26.7	39.5	41.2	81.2	2.94	91.2	27.6	39.9		
		70	53.3	81.1	2.95	91.2	27.5	39.9	57.0	83.6	2.98	93.8	28.1	40.2	60.7	86.1	3.01	96.4	28.6	40.5		
		90	71.8	88.1	3.03	98.4	29.1	40.7	76.0	89.6	3.05	100.0	29.4	40.8	80.1	91.1	3.07	101.6	29.6	41.0		
		110	90.4	95.0	3.10	105.6	30.6	41.5	95.0	95.5	3.12	106.1	30.6	41.5	99.6	96.0	3.14	106.7	30.6	41.6		
50	10	50	35.8	68.9	3.94	82.3	18.5	67.0	38.8	72.3	3.99	85.9	19.2	67.7	41.8	75.6	4.03	89.4	19.8	68.4		
		70	52.9	83.0	4.16	97.2	21.0	70.0	56.6	85.8	4.21	100.2	21.4	70.6	60.4	88.6	4.26	103.1	21.8	71.3		
		90	70.0	97.0	4.38	112.0	23.2	73.1	74.5	99.3	4.44	114.5	23.4	73.6	79.0	101.6	4.49	116.9	23.6	74.1		
		110	87.1	111.1	4.60	126.8	25.2	76.1	92.3	112.9	4.66	128.8	25.2	76.5	97.6	114.6	4.72	130.7	25.3	77.0		
	14.5	50	35.7	69.3	3.78	82.2	18.3	62.9	38.7	72.6	3.82	85.6	19.0	63.5	41.8	75.9	3.86	89.0	19.7	64.0		
		70	53.2	81.7	3.95	95.2	20.7	65.1	56.8	84.4	3.99	98.0	21.1	65.5	60.5	87.1	4.04	100.9	21.6	66.0		
		90	70.6	94.1	4.12	108.2	22.9	67.2	75.0	96.3	4.17	110.5	23.1	67.6	79.3	98.4	4.22	112.7	23.3	67.9		
		110	88.0	106.6	4.29	121.2	24.9	69.3	93.1	108.1	4.34	122.9	24.9	69.6	98.1	109.6	4.40	124.6	24.9	69.9		
	19	50	35.6	69.7	3.63	82.0	20.3	58.9	38.7	72.9	3.66	85.4	21.1	59.3	41.7	76.2	3.69	88.7	21.8	59.6		
		70	53.4	80.5	3.74	93.2	22.5	60.1	57.1	83.0	3.78	95.9	23.0	60.4	60.7	85.6	3.81	98.6	23.5	60.7		
		90	71.2	91.3	3.86	104.4	24.6	61.3	75.4	93.2	3.90	106.5	24.9	61.6	79.7	95.1	3.94	108.6	25.1	61.8		
		110	89.0	102.1	3.97	115.6	26.6	62.5	93.8	103.3	4.02	117.0	26.6	62.7	98.6	104.6	4.07	118.5	26.6	62.9		
70	10	50	36.8	63.8	4.74	80.0	13.5	86.5	39.6	66.7	4.78	83.0	13.9	87.1	42.4	69.6	4.82	86.1	14.4	87.7		
		70	53.3	80.8	5.03	98.0	16.1	90.2	57.0	83.6	5.08	101.0	16.5	90.8	60.6	86.4	5.14	104.0	16.8	91.4		
		90	69.8	97.8	5.31	115.9	18.4	93.9	74.3	100.5	5.38	118.9	18.7	94.5	78.8	103.3	5.45	121.9	18.9	95.1		
		110	Operation not recommended																			
	14.5	50	36.7	64.5	4.56	80.0	14.1	82.6	39.5	67.4	4.59	83.1	14.7	83.1	42.4	70.4	4.63	86.1	15.2	83.5		
		70	53.4	80.3	4.78	96.6	16.8	85.3	57.1	83.0	4.83	99.5	17.2	85.7	60.7	85.8	4.88	102.4	17.6	86.2		
		90	70.2	96.1	5.00	113.2	19.2	87.9	74.6	98.7	5.07	116.0	19.5	88.4	79.0	101.2	5.13	118.7	19.7	88.8		
		110	Operation not recommended																			
	19	50	36.6	65.1	4.37	80.0	14.9	78.7	39.4	68.1	4.40	83.1	15.5	79.0	42.3	71.1	4.43	86.2	16.0	79.4		
		70	53.6	79.8	4.53	95.2	17.6	80.3	57.2	82.5	4.57	98.1	18.0	80.6	60.8	85.1	4.62	100.9	18.4	80.9		
		90	70.5	94.4	4.68	110.4	20.2	82.0	74.9	96.8	4.75	113.0	20.4	82.3	79.2	99.2	4.81	115.6	20.6	82.5		
		110	87.5	109.1	4.84	125.6	22.5	83.6	92.6	111.2	4.92	127.9	22.6	83.9	97.7	113.2	5.00	130.3	22.6	84.1		
90	10	50	38.3	56.8	6.04	77.4	10.1	106.0	40.8	59.2	6.08	79.9	10.5	106.5	43.3	61.5	6.12	82.4	10.8	107.0		
		70	54.9	73.1	6.36	94.8	12.3	109.5	58.2	75.5	6.41	97.3	12.6	110.1	61.6	77.8	6.46	99.9	12.9	110.6		
		90	71.6	89.4	6.68	112.2	14.2	113.1	75.7	91.8	6.74	114.8	14.5	113.7	79.8	94.1	6.81	117.4	14.7	114.2		
		110	Operation not recommended																			
	14.5	50	38.1	57.5	5.82	77.4	9.9	102.2	40.7	59.9	5.85	79.9	10.2	102.6	43.2	62.4	5.88	82.4	10.6	103.0		
		70	54.9	73.2	6.07	93.9	12.1	104.8	58.2	75.5	6.11	96.4	12.4	105.2	61.6	77.9	6.16	98.9	12.6	105.6		
		90	71.7	88.8	6.32	110.4	14.0	107.5	75.8	91.1	6.38	112.9	14.3	107.9	79.9	93.4	6.43	115.3	14.5	108.2		
		110	Operation not recommended																			
	19	50	38.0	58.3	5.60	77.4	11.2	98.4	40.6	60.7	5.63	79.9	11.6	98.7	43.1	63.2	5.65	82.5	12.0	99.0		
		70	54.9	73.3	5.79	93.0	13.5	100.1	58.2	75.6	5.82	95.4	13.9	100.4	61.5	77.9	5.85	97.9	14.2	100.6		
		90	71.8	88.3	5.97	108.6	15.7	101.8	75.9	90.4	6.01	110.9	16.0	102.0	80.0	92.6	6.06	113.3	16.2	102.3		
		110	Operation not recommended																			
110	10	50	39.7	49.8	7.34	74.9	6.8	125.4	42.0	51.6	7.38	76.8	7.0	125.8	44.2	53.4	7.41	78.7	7.2	126.2		
		70	56.5	65.4	7.69	91.6	8.5	128.9	59.5	67.3	7.74	93.7	8.7	129.3	62.5	69.2	7.78	95.8	8.9	129.7		
		90	Operation not recommended																			
		110	Operation not recommended																			
	14.5	50	39.6	50.6	7.09	74.8	7.1	121.8	41.8	52.5	7.11	76.7	7.4	122.1	44.1	54.4	7.14	78.7	7.6	122.4		
		70	56.4	66.1	7.37	91.2	9.0	124.4	59.4	68.0	7.40	93.3	9.2	124.7	62.4	69.9	7.44	95.3	9.4	125.0		
		90	Operation not recommended																			
		110	Operation not recommended																			
	19	50	39.4	51.4	6.83	74.7	7.5	118.1	41.7	53.4	6.85	76.7	7.8	118.3	44.0	55.3	6.87	78.7	8.0	118.5		
		70	56.2	66.7	7.04	90.8	9.5	119.9	59.3	68.7	7.07	92.8	9.7	120.1	62.3	70.7	7.09	94.9	10.0	120.3		
		90	Operation not recommended																			
		110	Operation not recommended																			

075 - Performance Data cont.

Heating Capacity

Source		Load Flow-10 GPM							Load Flow-14.5 GPM							Load Flow-19 GPM						
EST °F	Flow GPM	ELT °F	LLT °F	HC MBTUH	Power kW	HE MBTUH	COP	LST °F	LLT °F	HC MBTUH	Power kW	HE MBTUH	COP	LST °F	LLT °F	HC MBTUH	Power kW	HE MBTUH	COP	LST °F		
25	14.5	60	Operation not recommended																			
		80	Operation not recommended																			
		100	Operation not recommended																			
		120	Operation not recommended																			
19	60	72.1	58.8	3.90	45.5	4.42	20.1	68.4	58.9	3.78	46.0	4.57	20.0	66.4	59.0	3.66	46.5	4.72	19.95			
	80	91.8	57.4	5.11	40.0	3.29	20.7	88.2	57.5	4.97	40.6	3.39	20.6	86.2	57.6	4.82	41.1	3.50	20.5			
	100	111.6	56.1	6.32	34.5	2.60	21.3	108.0	56.1	6.15	35.1	2.67	21.2	106.1	56.1	5.98	35.7	2.75	21.1			
	120	131.3	54.7	7.53	29.0	2.13	21.9	127.8	54.7	7.34	29.7	2.18	21.8	125.9	54.7	7.14	30.3	2.24	21.7			
30	10	60	72.6	61.1	3.90	47.8	4.59	20.1	69.6	61.2	3.79	48.3	4.74	20.0	66.7	61.3	3.68	48.7	4.88	20.0		
		80	92.3	59.7	5.12	42.3	3.42	21.3	89.4	59.8	4.99	42.8	3.52	21.2	86.5	59.9	4.85	43.3	3.61	21.1		
		100	112.0	58.4	6.35	36.7	2.69	22.4	109.2	58.4	6.19	37.3	2.77	22.3	106.3	58.4	6.03	37.9	2.84	22.2		
		120	131.8	57.0	7.57	31.2	2.21	23.6	129.0	57.0	7.39	31.8	2.26	23.4	126.2	57.0	7.20	32.4	2.32	23.3		
	14.5	60	73.1	63.5	3.9	50.1	4.74	22.2	70.0	63.6	3.82	50.5	4.88	22.2	66.9	63.7	3.7	51.0	5.03	22.1		
		80	92.7	61.7	5.2	44.1	3.51	23.2	89.7	61.8	5.02	44.6	3.60	23.1	86.7	61.9	4.9	45.2	3.71	23.0		
		100	112.4	59.9	6.4	38.1	2.75	24.1	109.4	60.0	6.23	38.7	2.82	24.0	106.5	60.1	6.1	39.4	2.90	23.9		
		120	132.0	58.2	7.6	32.1	2.24	25.0	129.2	58.2	7.43	32.8	2.29	24.9	126.3	58.3	7.2	33.5	2.36	24.8		
	19	60	73.6	65.8	3.95	52.3	4.88	24.3	70.4	65.9	3.84	52.8	5.03	24.3	67.2	66.0	3.73	53.3	5.18	24.2		
		80	93.1	63.6	5.19	45.9	3.59	25.0	90.0	63.7	5.05	46.5	3.70	25.0	86.9	63.8	4.92	47.1	3.80	24.9		
		100	112.7	61.5	6.43	39.5	2.80	25.7	109.7	61.6	6.27	40.2	2.88	25.6	106.7	61.7	6.10	40.8	2.96	25.6		
		120	132.2	59.3	7.67	33.1	2.27	26.4	129.3	59.4	7.48	33.9	2.33	26.3	126.5	59.5	7.29	34.6	2.39	26.2		
50	10	60	76.7	81.0	4.2	66.7	5.60	36.2	72.7	81.0	4.02	67.3	5.85	36.1	68.8	81.0	3.9	67.8	6.10	36.0		
		80	96.1	78.2	5.4	59.6	4.17	37.7	92.3	78.2	5.24	60.3	4.34	37.6	88.5	78.3	5.1	61.0	4.50	37.4		
		100	115.5	75.3	6.7	52.5	3.28	39.2	111.9	75.4	6.46	53.3	3.39	39.0	108.2	75.5	6.3	54.2	3.51	38.8		
		120	134.9	72.5	7.9	45.4	2.66	40.6	131.4	72.6	7.69	46.4	2.75	40.4	127.9	72.8	7.5	47.3	2.84	40.2		
	14.5	60	77.4	84.5	4.2	70.1	5.86	39.1	73.3	84.4	4.07	70.5	6.08	39.1	69.2	84.3	3.9	71.0	6.32	39.0		
		80	96.7	81.1	5.5	62.4	4.35	40.3	92.8	81.1	5.29	63.1	4.50	40.2	88.8	81.2	5.1	63.7	4.66	40.1		
		100	116.0	77.7	6.7	54.8	3.39	41.5	112.2	77.9	6.51	55.7	3.51	41.4	108.5	78.0	6.3	56.5	3.63	41.2		
		120	135.3	74.4	8.0	47.2	2.74	42.7	131.7	74.6	7.73	48.2	2.83	42.5	128.1	74.8	7.5	49.3	2.93	42.3		
	19	60	78.1	87.9	4.3	73.4	5.98	42.0	73.8	87.8	4.11	73.8	6.19	42.0	69.5	87.7	4.0	74.1	6.40	42.0		
		80	97.3	84.0	5.5	65.2	4.42	42.9	93.2	84.1	5.33	65.9	4.58	42.9	89.1	84.1	5.2	66.5	4.74	42.8		
		100	116.5	80.2	6.8	57.1	3.44	43.8	112.6	80.3	6.55	58.0	3.57	43.7	108.7	80.5	6.3	58.9	3.69	43.6		
		120	135.7	76.3	8.0	48.9	2.77	44.7	132.0	76.6	7.77	50.1	2.87	44.6	128.3	76.9	7.5	51.2	2.98	44.4		
70	10	60	80.8	100.9	4.48	85.6	6.60	52.3	75.9	100.8	4.26	86.3	6.96	52.2	70.9	100.7	4.03	86.9	7.32	52.1		
		80	99.9	96.6	5.74	77.0	4.93	54.1	95.2	96.6	5.50	77.8	5.16	54.0	90.5	96.6	5.26	78.7	5.39	53.8		
		100	119.0	92.2	7.00	68.3	3.86	55.9	114.5	92.4	6.74	69.4	4.02	55.7	110.0	92.6	6.48	70.4	4.18	55.5		
		120	138.1	87.9	8.26	59.7	3.12	57.7	133.9	88.2	7.99	60.9	3.24	57.4	129.6	88.5	7.71	62.2	3.36	57.2		
	14.5	60	81.7	105.5	4.5	90.0	6.84	56.0	76.6	105.2	4.32	90.5	7.14	56.0	71.4	105.0	4.1	91.0	7.48	55.9		
		80	100.7	100.5	5.8	80.8	5.09	57.5	95.8	100.5	5.55	81.5	5.30	57.4	90.9	100.5	5.3	82.3	5.53	57.2		
		100	119.7	95.6	7.0	71.5	3.97	58.9	115.1	95.7	6.79	72.6	4.13	58.7	110.4	95.9	6.5	73.7	4.31	58.6		
		120	138.7	90.6	8.3	62.2	3.19	60.3	134.3	91.0	8.02	63.6	3.32	60.1	129.9	91.4	7.7	65.0	3.46	59.9		
	19	60	82.7	110.0	4.55	94.5	7.08	59.7	77.3	109.7	4.38	94.7	7.35	59.7	71.9	109.3	4.20	95.0	7.62	59.7		
		80	101.5	104.4	5.82	84.6	5.26	60.8	96.4	104.4	5.60	85.2	5.47	60.7	91.3	104.3	5.39	85.9	5.67	60.7		
		100	120.4	98.9	7.09	74.7	4.09	61.9	115.6	99.1	6.83	75.8	4.26	61.8	110.8	99.3	6.57	76.9	4.43	61.7		
		120	139.2	93.3	8.36	64.8	3.27	63.0	134.7	93.8	8.06	66.3	3.42	62.8	130.2	94.3	7.76	67.8	3.56	62.6		
90	10	60	84.8	120.1	4.74	103.9	7.42	68.6	78.6	117.4	4.45	102.2	7.75	68.9	72.4	114.6	4.16	100.4	8.07	69.3		
		80	103.7	114.9	6.02	94.4	5.59	70.5	97.9	113.2	5.71	93.7	5.82	70.7	92.1	111.5	5.39	93.1	6.06	70.8		
		100	Operation not recommended																			
		120	Operation not recommended																			
	14.5	60	85.3	122.8	4.77	106.5	7.55	73.4	79.0	119.5	4.49	104.2	7.80	73.7	72.6	116.2	4.22	101.8	8.08	74.0		
		80	104.2	117.6	6.07	96.8	5.67	74.9	98.3	115.4	5.76	95.8	5.88	75.0	92.3	113.3	5.44	94.7	6.10	75.2		
		100	123.2	112.4	7.38	87.2	4.46	76.4	117.6	111.4	7.02	87.4	4.65	76.4	112.0	110.4	6.67	87.7	4.85	76.3		
		120	Operation not recommended																			
	19	60	85.9	125.4	4.79	109.1	7.67	78.2	79.3	121.6	4.53	106.1	7.88	78.5	72.8	117.8	4.27	103.2	8.08	78.8		
		80	104.8	120.2	6.13	99.3	5.75	79.2	98.6	117.7	5.81	97.9	5.95	79.4	92.5	115.2	5.49	96.4	6.15	79.5		
		100	123.7	115.0	7.46	89.5	4.51	80.3	118.0	113.8	7.08	89.6	4.72	80.3	112.2	112.5	6.70	89.7	4.92	80.3		
		120	Operation not recommended																			

Wiring Schematics

Aurora Control - 208-230/60/1

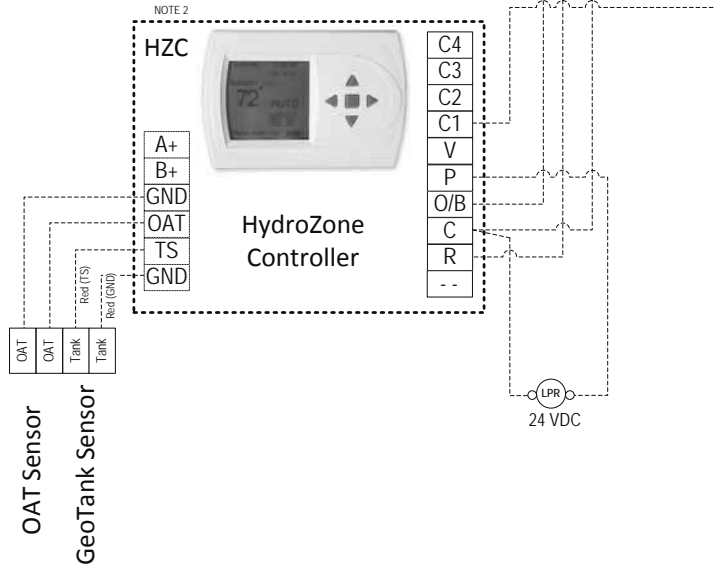
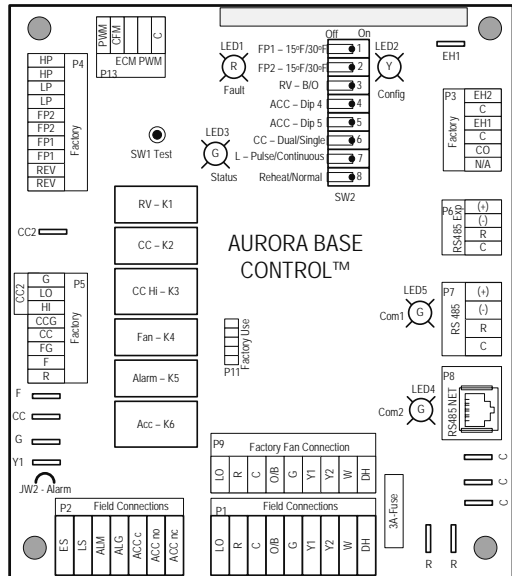
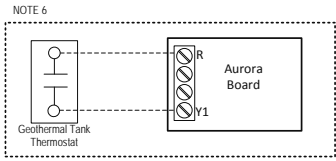
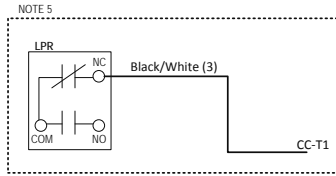
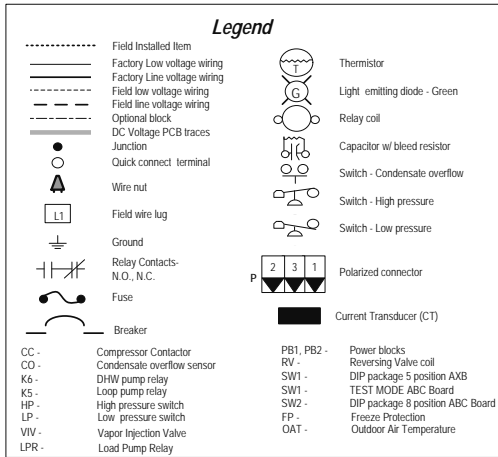
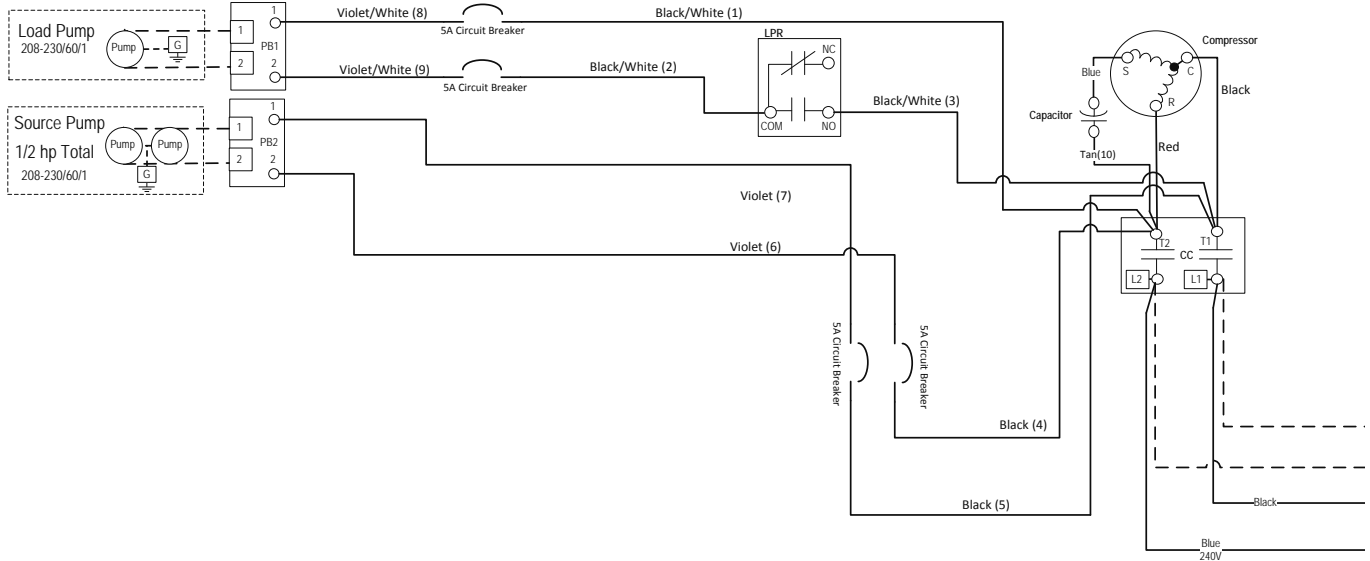

Wiring Schematics cont.

Aurora Control - 208-230/60/1

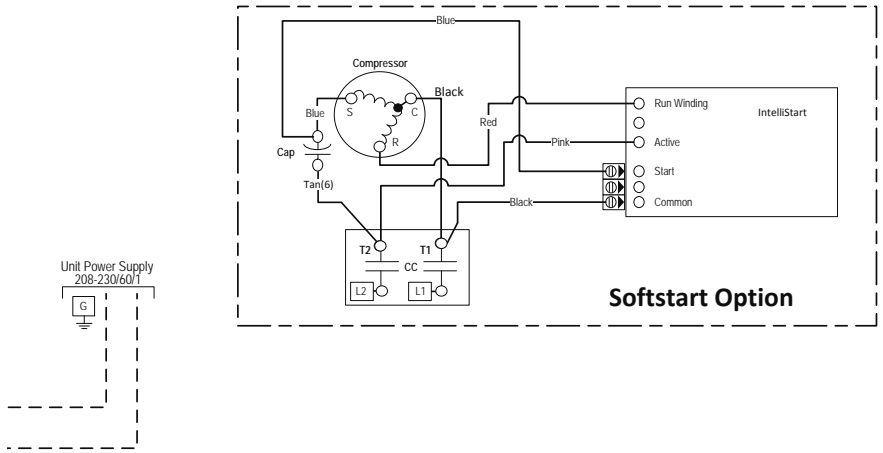

- ### Notes
- 1 - Switch blue and red wires for 208V operation.
 - 2 - HydroZone controller is an optional field installed accessory.
 - 3 - Reversing Valve wires not installed on heating only option
 - 4 - FP2 is replaced with a resistor on heating only option
 - 5 - Move black/white(3) wire when HydroZone or HydroStat not used for pump control connect wire to LPR-NC and CC-T1
 - 6 - When Geothermal Storage Tank is wired directly to the Aurora Board
 - 7 - HydroStat Communicating Controller is an optional field installed accessory.

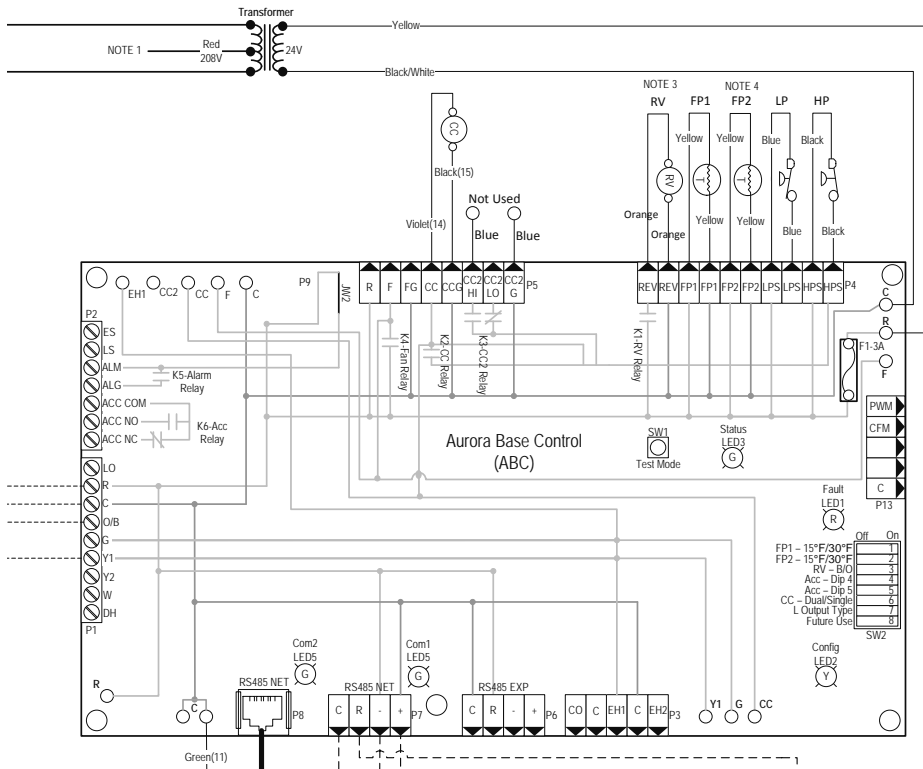

DESCRIPTION	SW2-4	SW2-5
Cycle with Blower	ON	ON
Cycle with Compressor	OFF	OFF
Water Valve Slow Opening	ON	OFF
Cycle with Comm. T-stat Hum Cmd	OFF	ON

Event	Normal Mode	Test Mode
Random Start Delay	5 to 80 seconds	1 second
Compressor On Delay	5 seconds	< 1 second
Compressor Minimum On Time	2 minutes	5 seconds
Compressor Short Cycle Delay	4 minutes	15 seconds
Fault Recognition Delay - High Pressure	Less than 1 second	Less than 1 second
Start-Up Bypass - Low Pressure	2 minutes	30 seconds
Fault Recognition Delay - Low Pressure	30 seconds	30 seconds
Start-Up Bypass - Low Water Coil Limit	2 minutes	30 seconds
Fault Recognition Delay - Low Water Coil Limit	30 seconds	30 seconds
Fault Recognition Delay - Condensate Overflow	30 seconds	30 seconds
HydroZone Call Recognition Time	2 seconds	2 seconds
Water Valve Slow Open Delay	90 seconds	90 seconds

Flash Code	Description	Configuration LED (LED2, Yellow)
Slow Flash	1 second on and 1 second off	
Fast Flash	100 milliseconds on and 100 milliseconds off	
Flash Code	100 milliseconds on and 400 milliseconds off with a 2 second pause before repeating	
Random Start Delay (Alternating Colors)		
Status LED (LED1, Green)	Fast Flash	No Software Override
Configuration LED (LED2, Yellow)	Fast Flash	DIP Switch Override
Fault LED (LED3, Red)	Fast Flash	
Fault LED (LED1, Red)		
Normal Mode	OFF	Normal Mode
Input Fault Lockout	Flash Code 1	Control is Non-Functional
High Pressure Lockout	Flash Code 2	Test Mode
Low Pressure Lockout	Flash Code 3	Lockout Active
Future Use	Flash Code 4	Dehumidification Mode
Freeze Detection - FP1	Flash Code 5	Future Use
Reserved	Flash Code 6	Future Use
Condensate Overflow Lockout	Flash Code 7	Load Shed
Over/Under Voltage Shutdown	Flash Code 8	ESD
Future Use	Flash Code 9	Future Use
Future Use	Flash Code 10	Future Use
FP1 and FP2 Sensor Error	Flash Code 11	

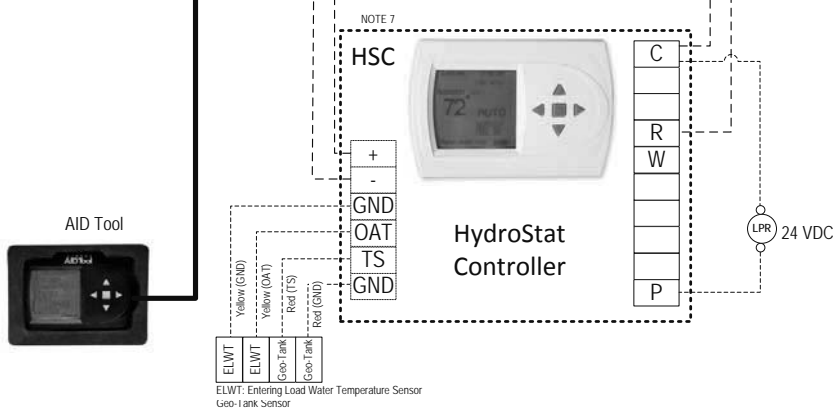

Wiring Schematics

Aurora Water-Water - 208-230/60/3

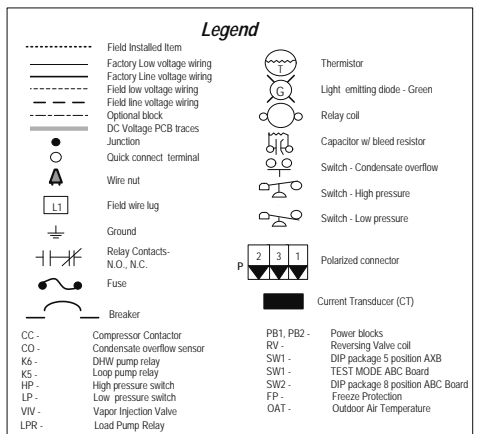
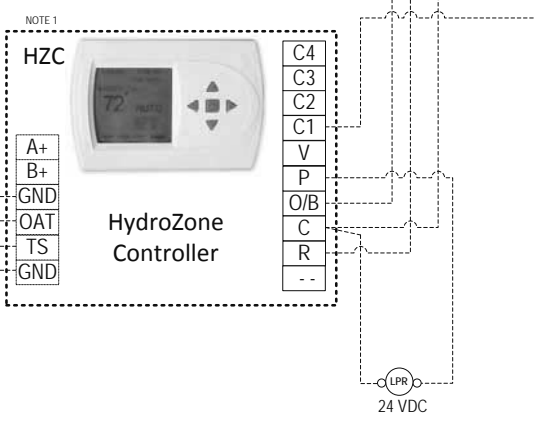
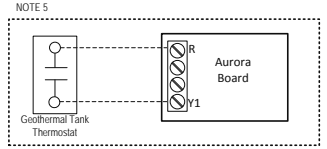
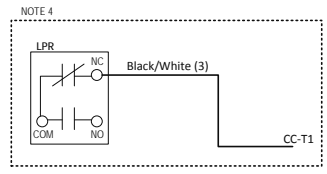
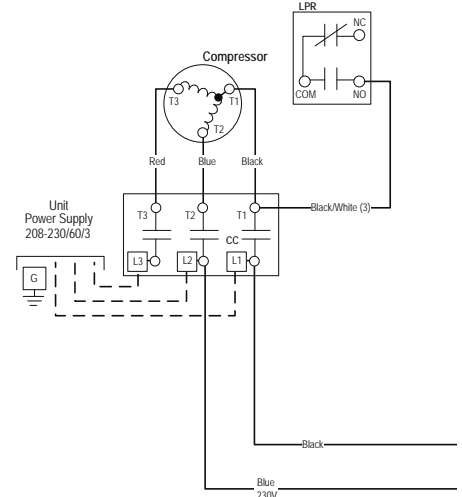
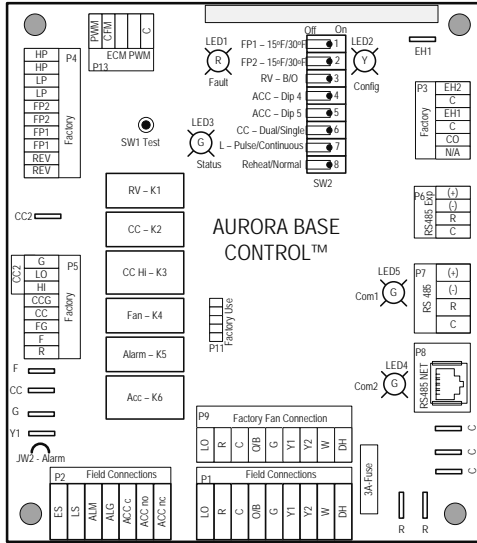

Wiring Schematics

Aurora Water-Water - 208-230/60/3

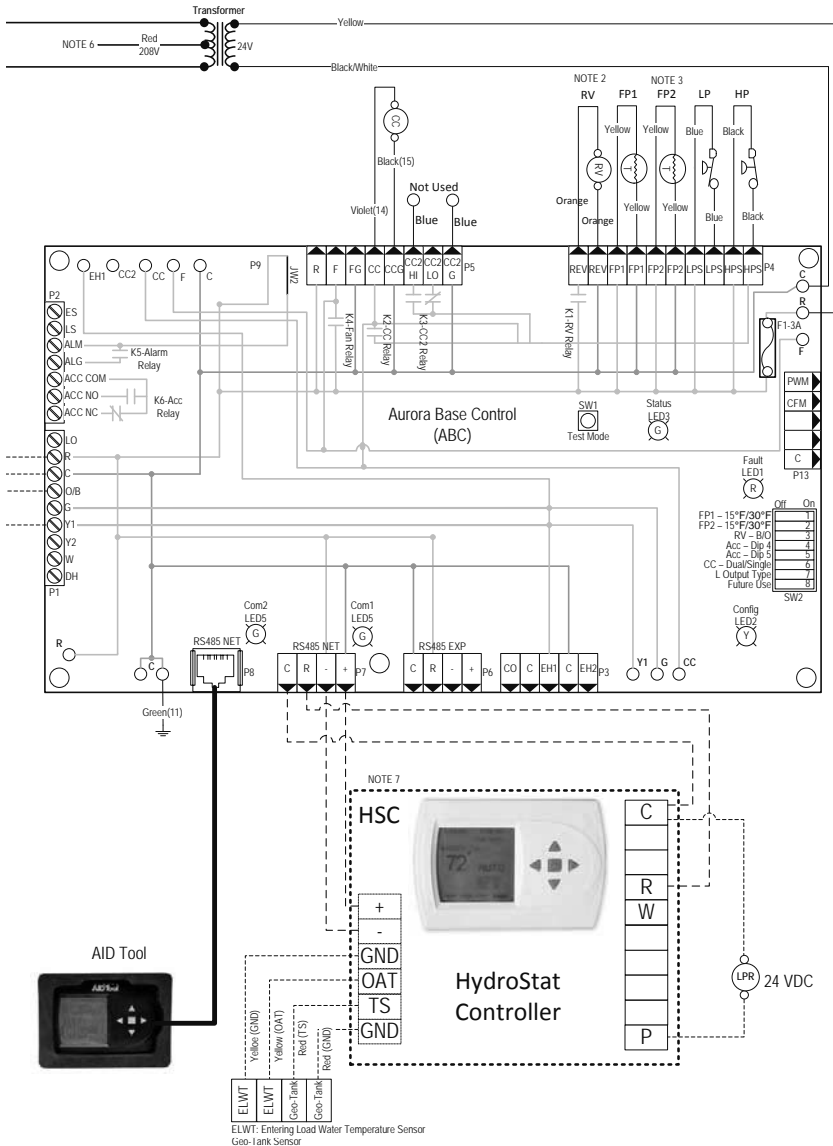
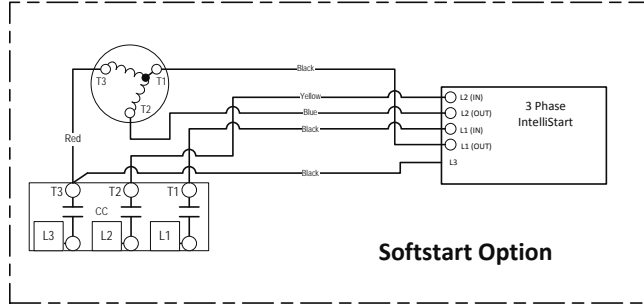

Aurora LED Flash Codes			
Slow Flash	1 second on and 1 second off		
Fast Flash	100 milliseconds on and 100 milliseconds off		
Flash Code	100 milliseconds on and 400 milliseconds off with a 2 second pause before repeating		
Random Start Delay (Alternating Colors)			
Status LED (LED1, Green)	Fast Flash	No Software Override	OFF
Configuration LED (LED2, Yellow)	Fast Flash	DIP Switch Override	Slow Flash
Fault LED (LED3, Red)	Fast Flash		
Fault LED (LED1, Red)		Status LED (LED3, Green)	
Normal Mode	OFF	Normal Mode	ON
Input Fault Lockout	Flash Code 1	Control is Non-Functional	OFF
High Pressure Lockout	Flash Code 2	Test Mode	Slow Flash
Low Pressure Lockout	Flash Code 3	Lockout Active	Fast Flash
Future Use	Flash Code 4	Dehumidification Mode	Flash Code 2
Freeze Detection - FP1	Flash Code 5	Future Use	Flash Code 3
Reserved	Flash Code 6	Future Use	Flash Code 4
Condensate Overflow Lockout	Flash Code 7	Load Shed	Flash Code 5
Over/Under Voltage Shutdown	Flash Code 8	ESD	Flash Code 6
Future Use	Flash Code 9	Future Use	Flash Code 7
Future Use	Flash Code 10		
FP1 and FP2 Sensor Error	Flash Code 11		

ABC SW2 Accessory Relay		
DESCRIPTION	SW2-4	SW2-5
Cycle with Blower	ON	ON
Cycle with Compressor	OFF	OFF
Water Valve Slow Opening	ON	OFF
Cycle with Comm. T-stat Hum Cmd	OFF	ON

Aurora Timing Events			
Event	Normal Mode	Test Mode	
Random Start Delay	5 to 80 seconds	1 second	
Compressor On Delay	5 seconds	< 1 second	
Compressor Minimum On Time	2 minutes	5 seconds	
Compressor Short Cycle Delay	4 minutes	15 seconds	
Fault Recognition Delay - High Pressure	Less than 1 second	Less than 1 second	
Start-Up Bypass - Low Pressure	2 minutes	30 seconds	
Fault Recognition Delay - Low Pressure	30 seconds	30 seconds	
Start-Up Bypass - Low Water Coil Limit	2 minutes	30 seconds	
Fault Recognition Delay - Low Water Coil Limit	30 seconds	30 seconds	
Fault Recognition Delay - Condensate Overflow	30 seconds	30 seconds	
HydroZone Call Recognition Time	2 seconds	2 seconds	
Water Valve Slow Open Delay	80 seconds	80 seconds	

Notes

- HydroZone controller is an optional field installed accessory.
- Reversing Valve wires not installed on heating only option.
- FP2 is replaced with a resistor on heating only option.
- Move black/white(3) wire when HydroZone or HydroStat is not used for pump control connect wire to LPR-NC and CC-T1.
- When Geothermal Storage Tank is wired directly to the Aurora Board.
- Switch blue and red wires for 208V operation.
- HydroStat Communicating controller is an optional field installed accessory.

Wiring Schematics - Commercial

Aurora Water-Water - 460/60/3

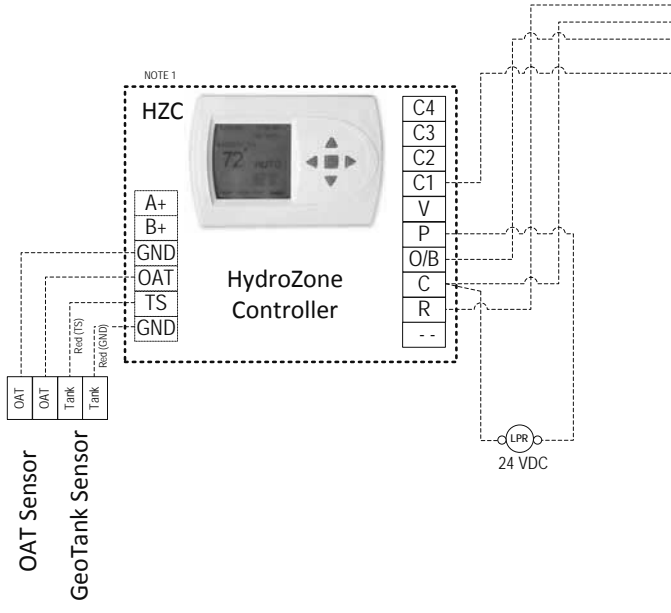
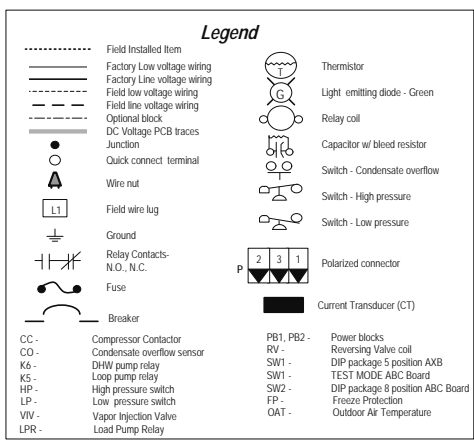
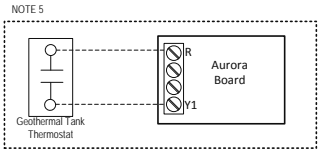
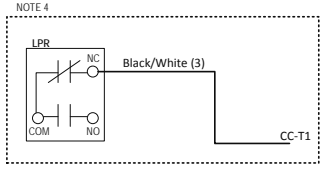
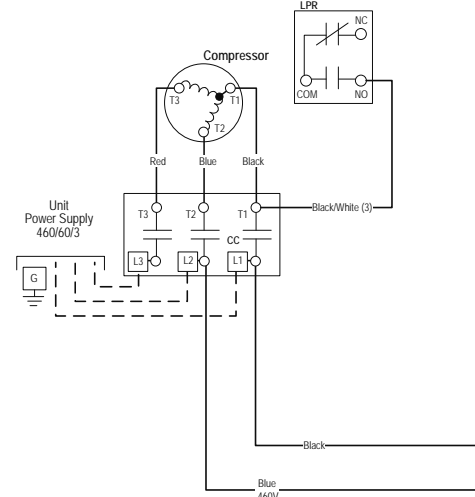
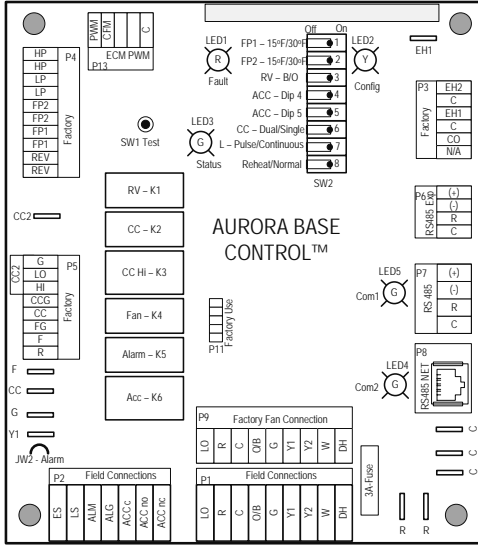

Wiring Schematics - Commercial cont.

Aurora Water-Water - 460/60/3

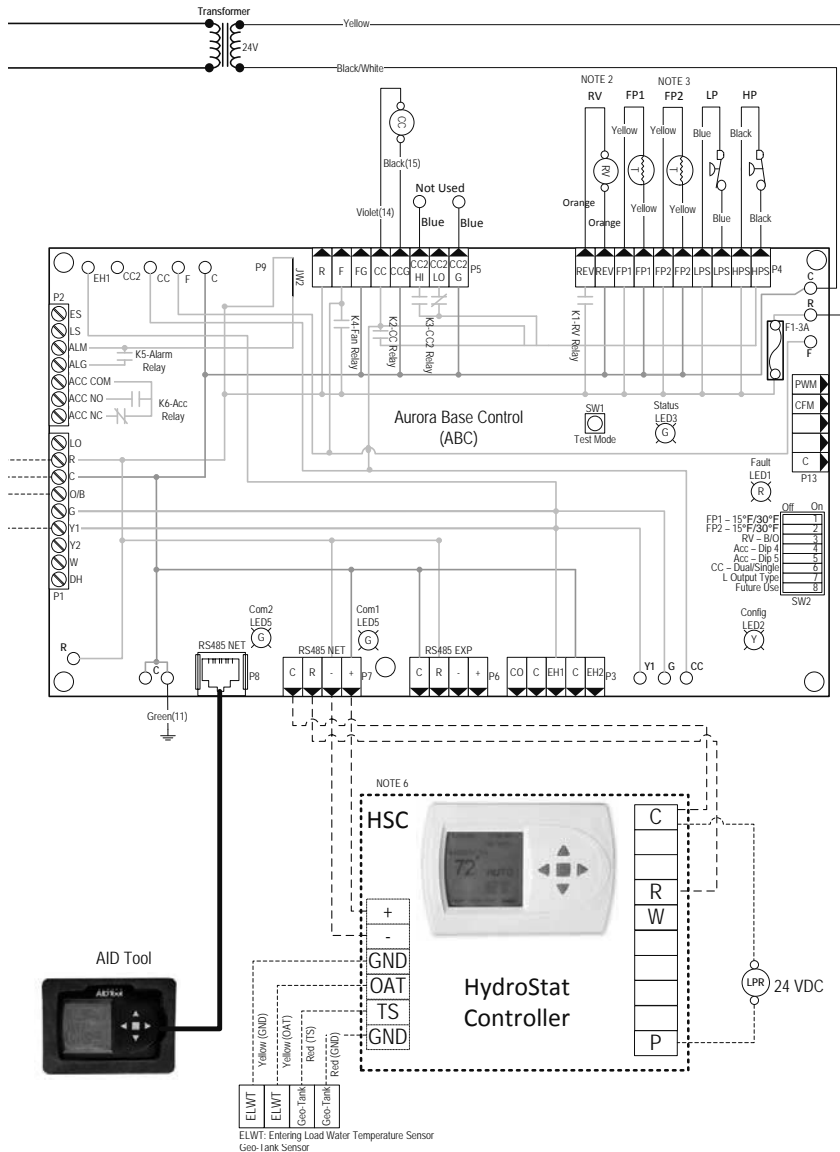
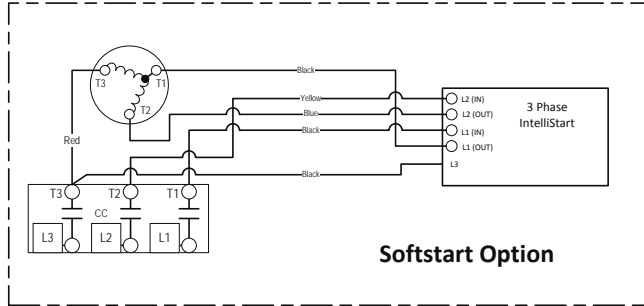

Aurora LED Flash Codes			
Slow Flash	1 second on and 1 second off		
Fast Flash	100 milliseconds on and 100 milliseconds off		
Flash Code	100 milliseconds on and 400 milliseconds off with a 2 second pause before repeating		
Random Start Delay (Alternating Colors)		Configuration LED (LED2, Yellow)	
Status LED (LED1, Green)	Fast Flash	No Software Override	OFF
Configuration LED (LED2, Yellow)	Fast Flash	DIP Switch Override	Slow Flash
Fault LED (LED3, Red)	Fast Flash		
Fault LED (LED1, Red)		Status LED (LED3, Green)	
Normal Mode	OFF	Normal Mode	ON
Input Fault Lockout	Flash Code 1	Control is Non-Functional	OFF
High Pressure Lockout	Flash Code 2	Test Mode	Slow Flash
Low Pressure Lockout	Flash Code 3	Lockout Active	Fast Flash
Future Use	Flash Code 4	Dehumidification Mode	Flash Code 2
Freeze Detection - FP1	Flash Code 5	Future Use	Flash Code 3
Reserved	Flash Code 6	Future Use	Flash Code 4
Condensate Overflow Lockout	Flash Code 7	Load Shed	Flash Code 5
Over/Under Voltage Shutdown	Flash Code 8	ESD	Flash Code 6
Future Use	Flash Code 9	Future Use	Flash Code 7
Future Use	Flash Code 10		
FP1 and FP2 Sensor Error	Flash Code 11		

ABC SW2 Accessory Relay		
DESCRIPTION	SW2-4	SW2-5
Cycle with Blower	ON	ON
Cycle with Compressor	OFF	OFF
Water Valve Slow Opening	ON	OFF
Cycle with Comm. T-stat Hum Cmd	OFF	ON

Aurora Timing Events		
Event	Normal Mode	Test Mode
Random Start Delay	5 to 80 seconds	1 second
Compressor On Delay	5 seconds	< 1 second
Compressor Minimum On Time	2 minutes	5 seconds
Compressor Short Cycle Delay	4 minutes	15 seconds
Fault Recognition Delay - High Pressure	Less than 1 second	Less than 1 second
Start-Up Bypass - Low Pressure	2 minutes	30 seconds
Fault Recognition Delay - Low Pressure	30 seconds	30 seconds
Start-Up Bypass - Low Water Call Limit	2 minutes	30 seconds
Fault Recognition Delay - Low Water Call Limit	30 seconds	30 seconds
Fault Recognition Delay - Condensate Overflow	30 seconds	30 seconds
HydroZone Call Recognition Time	2 seconds	2 seconds
Water Valve Slow Open Delay	90 seconds	90 seconds

- Notes**

 - 1 - HydroZone controller is an optional field installed accessory.
 - 2 - Reversing Valve wires not installed on heating only option
 - 3 - FP2 is replaced with a resistor on heating only option
 - 4 - Move black/white(3) wire when HydroZone or HydroStat is not used for pump control connect wire to LPR-NC and CC-T1
 - 5 - When Geothermal Storage Tank is wired directly to the Aurora Board
 - 6 - HydroStat communicating controller is an optional field installed accessory.

Accessories and Options

IntelliStart

IntelliStart is a single phase compressor soft starter which reduces the normal start current (LRA) by 60-70%. It should be used in applications that require low starting amps, reduced compressor start-up noise, off-grid, and improved start-up behavior. IntelliStart is available as a factory installed option or a field installed kit (**IS60RKL** or **IS60RKS**). IntelliStart is available on 208-230/60/1 voltage.

Water Connection Kits (Field Installed)

Water connection kits are available to facilitate loop side and load side water connections.

- **MA4FPT** - Forged brass 1" MPT x 1" FPT square street elbow with P/T plug for 018-040 water side connections
- **MA5FPT** - Forged brass 1.25" MPT x 1.25" FPT square street elbow with P/T plug for 050-075 water side connections
- **WFI-HKM-100-24-MO** - 1 inch x 24 inch stainless steel braided hose kit
- **WFI-HKM-125-24-MO** - 1 1/4 inch x 24 inch stainless steel braided hose kit

Earth Loop Pump Kit (Field Installed)

A specially designed one or two-pump module provides all liquid flow, fill and connection requirements for independent single unit systems (230/60/1 only). The one-pump module (FC1-FPT or FC1-GL) is capable of 25 feet of head at 16.0 GPM, while the two-pump module (FC2-FPT or FC2-GL) is capable of 50 feet of head at 16.0 GPM.

Hot Water Generator (Factory Installed, 040, 050, 060, and 075 Only)

An optional heat reclaiming hot water generator coil constructed of vented double-wall copper construction suitable for potable water is available. The coil is factory mounted inside the unit. A DPK5 pump kit (230/60/1) is required (field installed), which includes a DHW tank connection and a temperature limit pump shutoff.

Load-side Pump Kit (Field Installed)

Four (4) load pump kits are available to provide all liquid flow requirements for independent single unit systems (230/60/1 only). Our part number **24S516-10** (Grundfos UPS15-42RU) is a composite body pump. **EWPK2** (Grundfos UP26-64BF) is bronze body pump. Bronze or composite body pumps should be used when water conditions exist that are not compatible with cast iron or for applications such as domestic water heating. Our part numbers **EWPK1** and **EWPK3** come with a cast iron body pumps (Grundfos UP26-99F) that can be used for hydronic heating applications.

Calculate the system pressure drop then refer to the pump curves in figures 7 and 8 to select the proper pump. All

four (4) of the pump kits can be used for hydronic heating applications as long as they meet the flow requirements. If the flow requirements are outside the pump curve, an alternate pump will need to be obtained to maintain the necessary flow.

- **24S516-10** - UPS15-42RU composite PPS, 3/4 inch union sweat connection
- **EWPK1** - UP26-99F cast iron volute, 1 inch FPT flange connection
- **EWPK2** - UP26-64BF bronze volute, 1 inch FPT flange connection
- **EWPK3** - UP26-99F cast iron volute, 1-1/4 inch FPT flange connection

HydroStat Tank Controller

The **HydroStat** is a communicating tank controller that provides setpoint control and single stage operation.

HydroZone Tank Controller

The **HZC** tank controller provides outdoor reset with warm weather shutdown, setpoint control, process control, and single stage operation. If multiple stages of operation are required the HZO tank controller will allow up to four stages of operation.

HZAB

This is used in conjunction with the HydroStat and HydroZone tank controller to control the Geo-Storage tank electric heating element.

Figure 7: UPS15-42RU Three-Speed Pump Curve

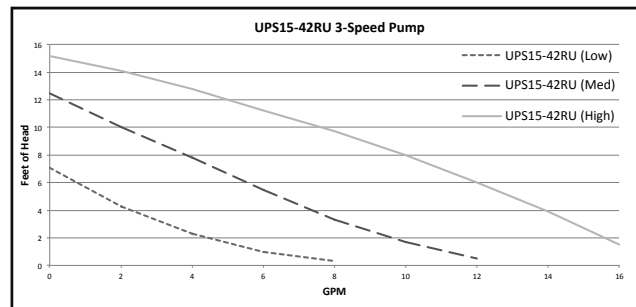
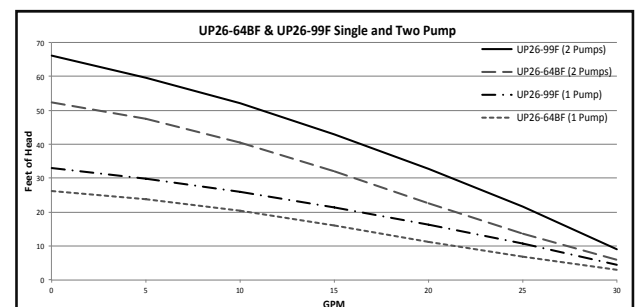
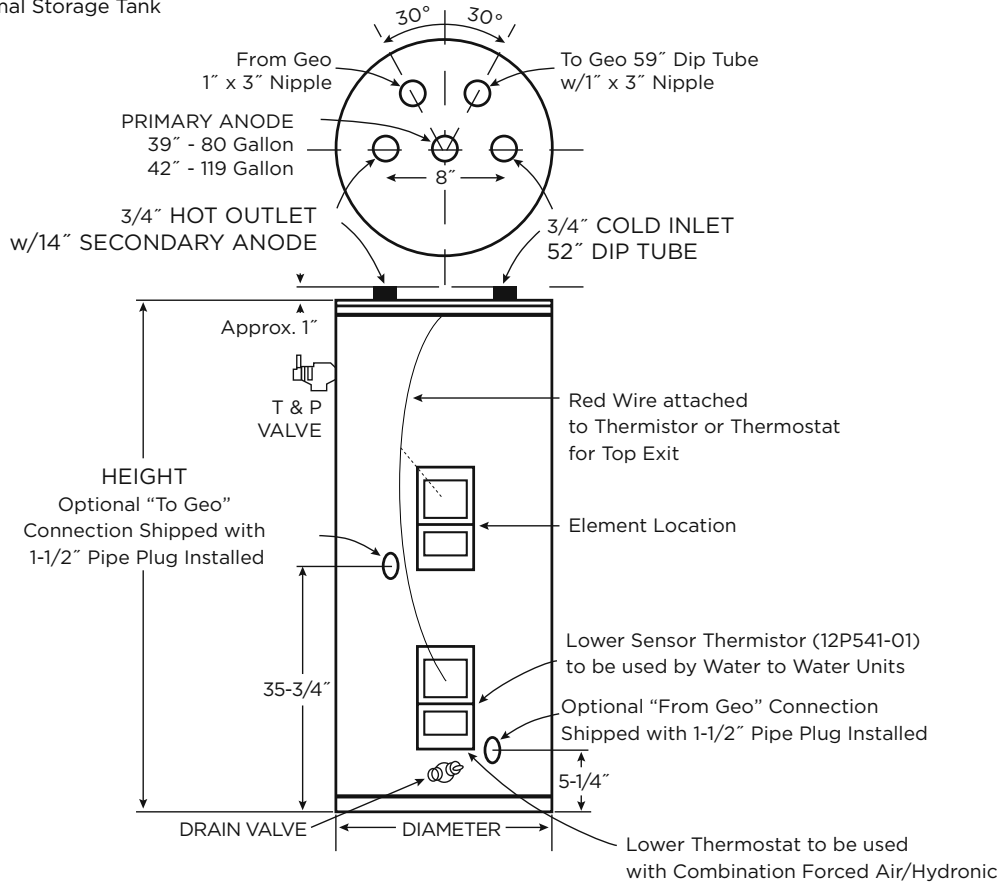

Figure 8: UP26-64BF and UP26-99F Single and Two Pump Curve



Accessories and Options cont.

Figure 9: Geothermal Storage Tank



MODEL NUMBER	GALLON CAPACITY	ELEMENT WATTAGE (240 VOLT)	NUMBER OF ELEMENTS	R VALUE	DIMENSIONS IN INCHES		APPROX. SHIPPING WEIGHT (lbs.)
					HEIGHT	DIAMETER	
GEO-STORAGE-80	80	4500	1	16	63-1/4	24	204
GEO-STORAGE-120	119	4500	1	16	63-1/4	28	311

Engineering Guide Specifications

General

The liquid source water-to-water heat pump shall be a single packaged heating only or reverse-cycle heating/cooling unit. Dedicated non-reversing heating only units shall be easily field convertible to cooling only units. The unit shall be listed by a nationally recognized safety-testing laboratory or agency, such as ETL Testing Laboratory, Underwriters Laboratory (UL), or Canadian Standards Association (CSA). The unit shall be rated in accordance with Air Conditioning, Heating, and Refrigeration Institute/International Standards Organization (AHRI/ISO) and Canadian Standards Association (CSA-US). The liquid source water-to-water heat pump unit shall be designed to operate with source liquid temperatures between 30°F [-1.1°C] and 110°F [43.3°C] in cooling, and between 25°F [-3.9°C] and 90°F [32.2°C] in heating.

Casing and Cabinet

The cabinet shall be fabricated from heavy-gauge galvanized steel and finished with corrosion-resistant powder coating. This corrosion protection system shall meet the stringent 1,000 hour salt spray test per ASTM B117. The interior shall be insulated with ½ in. thick, multi-density, coated glass fiber for noise suppression.

All units shall have separate holes and knockouts for entrance of line voltage and low voltage control wiring. All factory-installed wiring passing through factory knockouts and openings shall be protected from sheet metal edges at openings by plastic ferrules. The control box shall be field switchable from front to back for improved application flexibility with quick attach low voltage harnesses. The control box is shipped standard on the same end as the water connections.

Refrigerant Circuit

All units shall utilize the non-ozone depleting and low global warming potential refrigerant R-410A. All units shall contain a sealed refrigerant circuit including a hermetic motor-compressor, bidirectional thermostatic expansion valve, optional reversing valve, coaxial tube water-to-refrigerant heat exchanger, optional hot water generator coil, and service ports. An optional vented double wall load coaxial water-to-refrigerant heat exchanger is available on 018 and 025.

Compressors shall be high-efficiency scroll type designed for heat pump duty and mounted on vibration isolators. The compressor shall be double isolation mounted using selected durometer grommets to provide vibration free compressor mounting. All models will feature a compressor discharge muffler to help quiet compressor gas pulsations. A high density sound attenuating blanket shall be factory installed around the compressor to reduce sound. Compressor motors shall be single-phase PSC with overload protection.

The coaxial water-to-refrigerant heat exchangers shall be designed for low water pressure drop and constructed of a convoluted copper (cupronickel option) inner tube and a steel outer tube. Refrigerant-to-water heat exchangers shall be of copper inner water tube and steel refrigerant outer tube design, rated to withstand 600 PSIG (4135 kPa) working refrigerant pressure and 450 PSIG (3101 kPa) working water pressure. The thermostatic expansion valve shall provide proper superheat over the entire liquid temperature range with minimal "hunting." The valve shall operate bidirectionally without the use of check valves.

Option: Cupronickel refrigerant-to-water heat exchanger shall be of copper-nickel inner water tube and steel refrigerant outer tube design, rated to withstand 600 PSIG (4135 kPa) working refrigerant pressure and 450 PSIG (3101 kPa) working water pressure.

Option: Hot Water Generator (available on 040-075)

- Internal double wall vented hot water generator coil refrigerant to water heat exchangers suitable for potable water shall be of copper inner water tube and steel refrigerant outer tube design, rated to withstand 600 PSIG (4135 kPa) working refrigerant pressure and 450 PSIG (3101 kPa) working water pressure.

Option: Vented double wall water-to-refrigerant heat exchange (available on 018 and 025) - Internal vented double wall water-to-refrigerant coaxial heat exchangers suitable for potable water shall be of copper inner water tube and steel refrigerant outer tube design, rated to withstand 600 PSIG (4136 kPa) working refrigerant pressure and 450 PSIG (3101 kPa) water pressure.

Piping and Connections

Supply and return water connections shall be 1 in. [25.4 mm] for the 018-040, 1 ¼ in. [31.75 mm] for the 050-075, and all hot water generator water connections shall be ½ in. [12.7 mm] FPT copper fittings. The FPT fittings shall be fixed to the cabinet by use of a captive fitting, which eliminates the need for backup pipe wrenches.

Electrical

A control box shall be located within the unit compressor compartment and shall contain a 75VA transformer, 24 volt activated, 2 or 3 pole compressor contactor, circuit breakers for protecting pumps, terminal block for thermostat wiring, and solid-state controller for complete unit operation. Electromechanical operation WILL NOT be accepted. Units shall be name-plated for use with time delay fuses or HACR circuit breakers. Unit controls shall be 24 volt and provide heating or cooling as required by the remote thermostat/sensor.

Engineering Guide Specifications cont.

An Aurora, a microprocessor-based controller, interfaces with an external control to monitor and control unit operation shall be provided. The unit control shall provide operational sequencing, high and low pressure switch monitoring, freeze detection, lockout mode control, hot water, load and loop pump control, LED status and fault indicators, fault memory, field selectable options, and accessory output. The Lockout signal output shall have a pulsed option so that DDC systems can read specific lockout conditions from the control.

A detachable terminal block with screw terminals will be provided for field control wiring. All units shall have knockouts for entrance of low and line voltage wiring. The blower motor and control box shall be harness plug wired for easy removal.

An optional Aurora Interface Diagnostic (AID) Tool shall communicate with the Aurora control allowing quick and easy access to monitoring, and troubleshooting of any Aurora control. The device shall include the features fault description and history, manual operation capability, sensor readings, timings, and other diagnostic tools.

Optional IntelliStart® (compressor Soft Starter) shall be factory installed for use in applications that require low starting amps, reduced compressor start-up noise, off-grid, and improved start-up behavior. IntelliStart shall reduce normal starting current by up to 60%.

Accessories

Hose Kits - Automatic Balancing and Ball Valves with 'Y' strainer (field-installed)

WaterFurnace P/N - WFI-HKM-100-24-MO

(1 in. hose kit for 018-040)

WFI-HKM-125-24-MO

(1 1/4 in. hose kit for 050-075)

A flexible steel braid hose featuring Kevlar® reinforced EPDM core with ANSI 302/304 stainless steel outer braid and fire rated materials per ASTM E 84-00 (NFPA 255, ANSI/UL 723 & UBC 8-1). Ball valve at one end; swivel connector with adapter at the other end (swivel to adapter connection via fiber or EPDM gasket). Swivel connection provides union between heat pump and piping system. The hoses feature brass fittings, stainless steel ferrules. A "y" strainer is provided on one end for fluid straining and integral "blowdown" valve. A full port ball valve shall be provided with integral P/T (pressure/temperature) port on supply hose and automatic balancing valve with integral P/T ports and full port ball valve on return hose.

Specifications:

- Temperature range of 35°F [2°C] to 180°F [82°C].
- Max. working pressure of 400 psi [2756 kPa] for 1/2 in. and 3/4 in. hose kits; max. working pressure of 350 psi [2413 kPa] for 1 in. and 1 1/4 in. hose kits.
- Minimum burst pressure of four times working pressure.

Notes

Revision Guide

Pages:	Description:	Date:	By:
All	Commercial Guide Creation	08 June 2016	JM

