



Heating and Air Conditioning

**SPECIFICATION CATALOG**

**SAH AIR HANDLER & AIR COIL  
GEOTHERMAL HEAT PUMPS  
SINGLE AND DUAL CAPACITY**

**MODELS:**

**SAH022 - 060**

**SRAC026 - 060**

**(2 THRU 6 NOMINAL TONS)**



Due to continuous product improvement, specifications are subject to change without notice.

Visit us on the web at [www.york-geothermal.com](http://www.york-geothermal.com)

Additional rating information can found at [www.ahridirectory.org](http://www.ahridirectory.org)

FOR DISTRIBUTION USE ONLY - NOT TO BE USED AT POINT OF RETAIL SALE



## Table of Contents

---

Model Nomenclature . . . . .	4
Physical Data . . . . .	4
Air Handler Features and Benefits . . . . .	5-6
Dimensional Data - DX Air Handler . . . . .	7-8
Electrical Data . . . . .	9
Compatibility . . . . .	9
Wiring Schematics . . . . .	10-19
SAH 5 Speed ECM Blower Performance Data Option A . . . . .	20-21
Blower Performance Data Option C . . . . .	22-24
SR Encased/Uncased Coil Nomenclature . . . . .	25
Refrigerant Coil Compatibility . . . . .	25
Coil Physical Characteristics . . . . .	25
Dimensional Data . . . . .	26
SR Cased Coil Air Side Pressure Drop (Inches of WC) . . . . .	26
Dimensional Data - DX Cased Coils . . . . .	27
Engineering Guide Specifications . . . . .	28
Revision Guide . . . . .	29

# Nomenclature

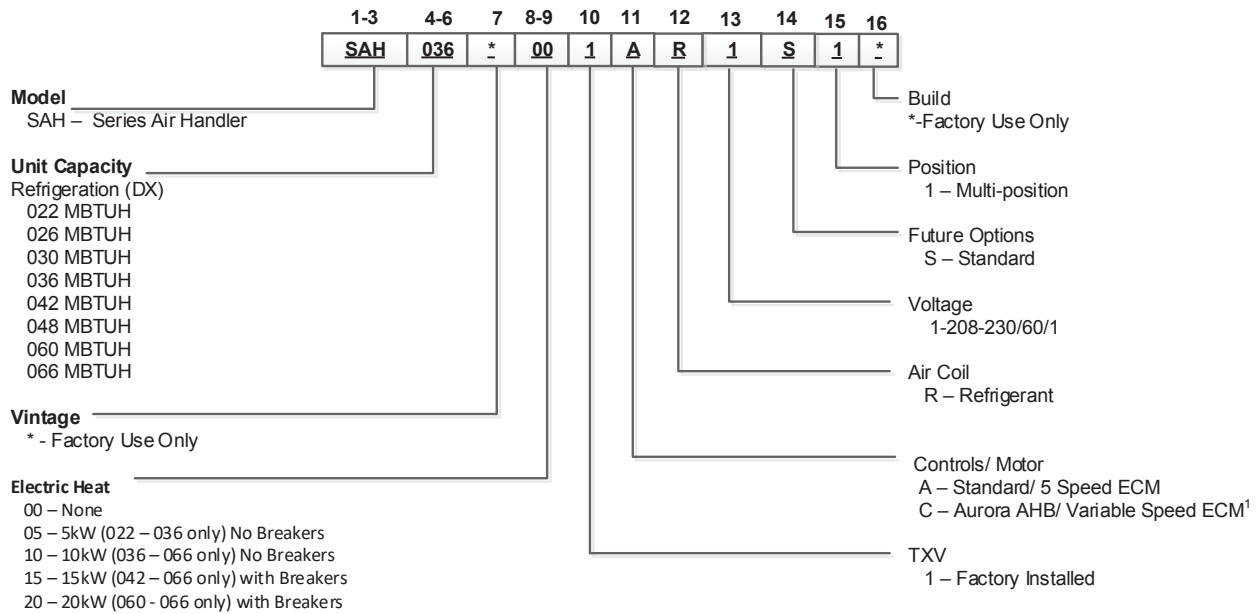

Note: To field convert the SAH to bottomflow air discharge, the SAHBCK kit must be ordered.

Rev.: 2/27/2017

Note: Air flow on the 060 and 066 units in the horizontal configurations should be limited to 1900 cfm in cooling mode, or condensate blow off may occur.

1. Only available with Aurora controls in the compressor section.

# Physical Data

Air Handler Model Number (Refrigerant)		022	026	030	036	042	048	060	066
<b>Evaporator Coil</b>	Air Coil Total Face Area, ft2 [m2]	3.89 [0.36]			4.86 [0.45]	5.83 [0.54]		6.81 [0.63]	
	Tube outside diameter - in. [mm]	3/8 [9.52]							
	Number of rows	3							
	Fins per inch	12							
	Suction line connection - in. [mm] sweat	5/8 [15.87]			3/4 [19.05]			7/8 [22.23]	
Liquid line connection - in. [mm] sweat				3/8 [9.52]			1/2 [12.7]		
Refrigerant	R-410a								
Nominal cooling capacity - tons [kW]	1.8 [6.44]	2.1 [7.59]	2.5 [8.79]	3 [10.55]	3.5 [12.30]	4 [14.06]	5 [17.58]	5.5 [19.33]	
Condensate drain connection - (FPT) in. [mm]	3/4 [19.05]								
Blower Wheel Size (Dia x W), in. [mm]	9 X 7 [229 x 178]			10 X 8 [254 x 203]		11 x 10 [279 x 254]			
Blower motor type/speeds	Variable Speed ECM/ 5 Speed ECM								
Blower motor output - hp [W]	1/2 [373]					1 [746]			
Filter Standard - 1" [51mm] Field Supplied.	16 X 20 [406 X 508]			20 X 20 [508 x 508]		22 X 20 [559 x 508]			
Electrical characteristics (60Hz)	208/230 - 1ph								
Shipping weight - lbs. [kg]	147 [66.7]			168 [76.2]		198 [89.6]		206 [93.4]	
Operating weight - lbs. [kg]	139 [63.0]			150 [68.0]		180 [81.6]		188 [85.3]	

1/31/2017

# Air Handler Features and Benefits

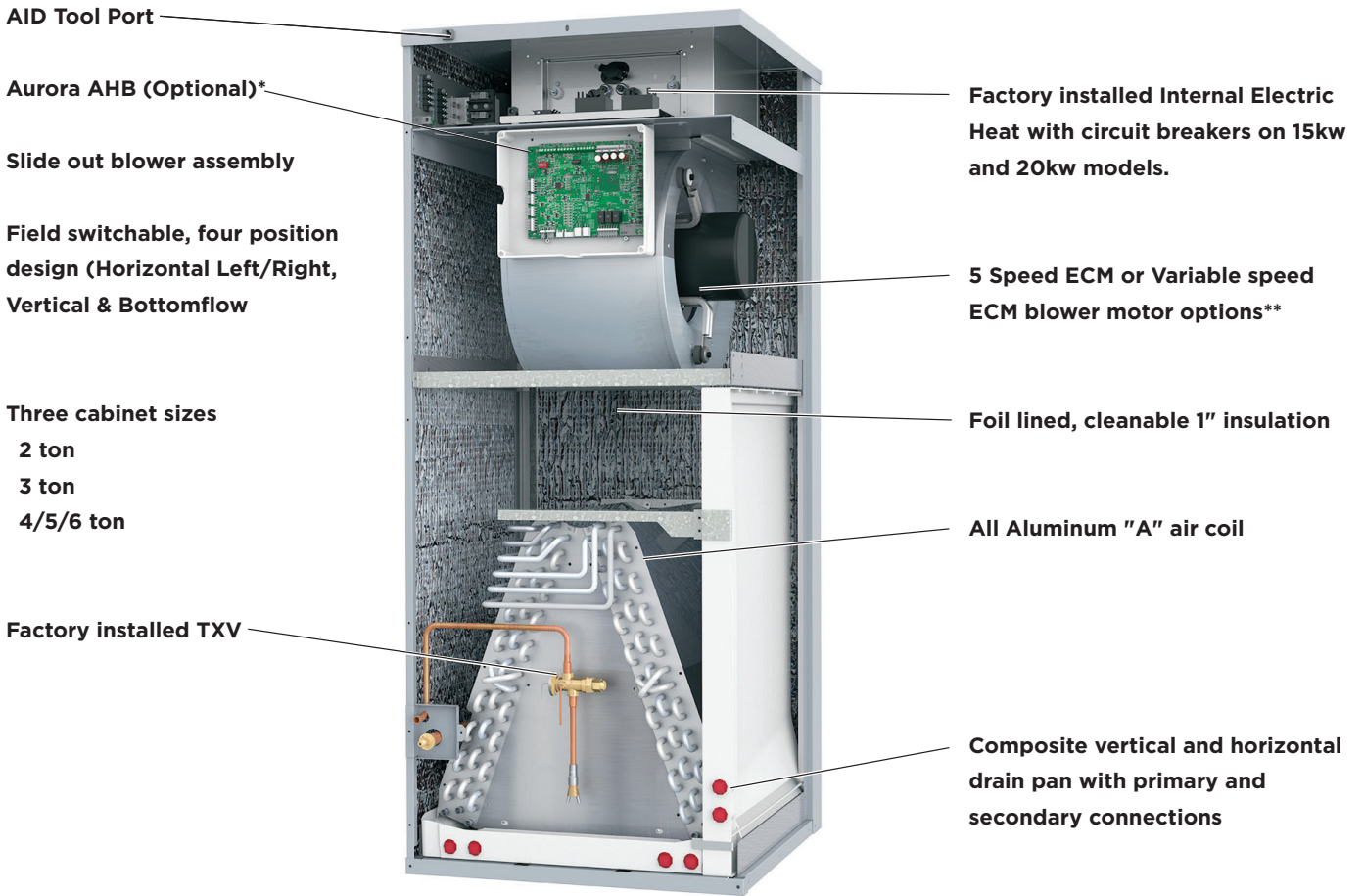

\* Compressor section must have Aurora Controls  
 \*\*Variable speed ECM requires AHB Controls

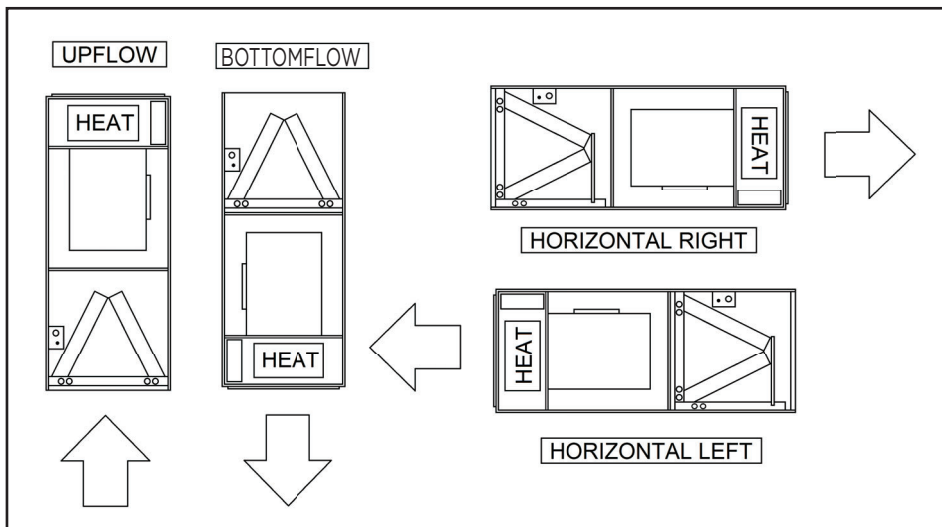

**FIGURE 3: Typical Installation**  
 Note: Air flow on the O60 and O66 units in the horizontal configuration should be limited to 1900 CFM in cooling mode, or condensate blow off may occur.

## Air Handler Features and Benefits cont.

### Air Coil

Designed for R-410A refrigerant. Configured as an 'A' coil, aluminum tubes and enhanced corrugated lanced aluminum fins to provide high efficiencies at low face velocities.

### Cabinet

Constructed of heavy gauge environmentally-responsible galvanized steel for maximum corrosion resistance. All units are painted with a powder coat finish. All interior surfaces are lined with 1" thick, foil lined acoustic type fiber insulation, applied in a manner that prevents the introduction of glass fibers into the air stream. Multiple knockouts in various sizes facilitate power and low voltage wiring. Multiple access panels for ease of service.

### Factory Sealed

Achieves 2% or less total airflow leakage rate.

### Installation Ease

Cabinets are shipped in one piece but can be separated for ease of installation in tight spaces.

### Auxiliary/ Emergency Electric Heat

Electric heat packages can be factory or field installed. For field installed electric heat the Auxiliary Heat Compatibility table below shows the available heater packages for the air handler.

### Configurations

Cabinets are factory configured for upflow and horizontal right hand air discharge installation but can be easily configured for horizontal left hand or bottomflow air discharge.

### Drain Pans

Two composite drain pans included. One for vertical and one for horizontal applications. The pans come equipped with primary and secondary drain connections.

### Electrical Disconnect

Factory installed circuit breaker on 15kW/20kW heaters.

### Expansion Device

Factory installed TXV with internal check valve inside of cabinet.

### Refrigerant Connections

Suction and liquid lines have sweat connections extended outside of cabinet for ease of connection.

### Controls

The SAH Air Handler has two control options.

Control option 'A' has a terminal strip board that uses the 24V input from the thermostat to control the 5 speed ECM motor.

Control option 'C' has the AHB board. The AHB is part of the Aurora controls platform and communicates via modbus to the ABC. The AHB board controls the air handlers variable speed motor, auxiliary heat staging, provides condensate overflow protection, air coil freeze protection FP2, auxiliary heat and blower energy monitoring, leaving air temperature, with Aurora controls in the compressor section..

### Auxiliary Heat Compatibility

Model	kW	Stages	Air Handler Compatibility				
			022 - 030	036	042 - 048	060	066
19P659-01	5	1	X	X			
19P659-02	10	2		X	X	X	X
19P659-03	15	2			X	X	X
19P659-04	20	2				X	X

1/10/2017

## Dimensional Data - DX Air Handler

### Top Flow/Horizontal Unit Configuration

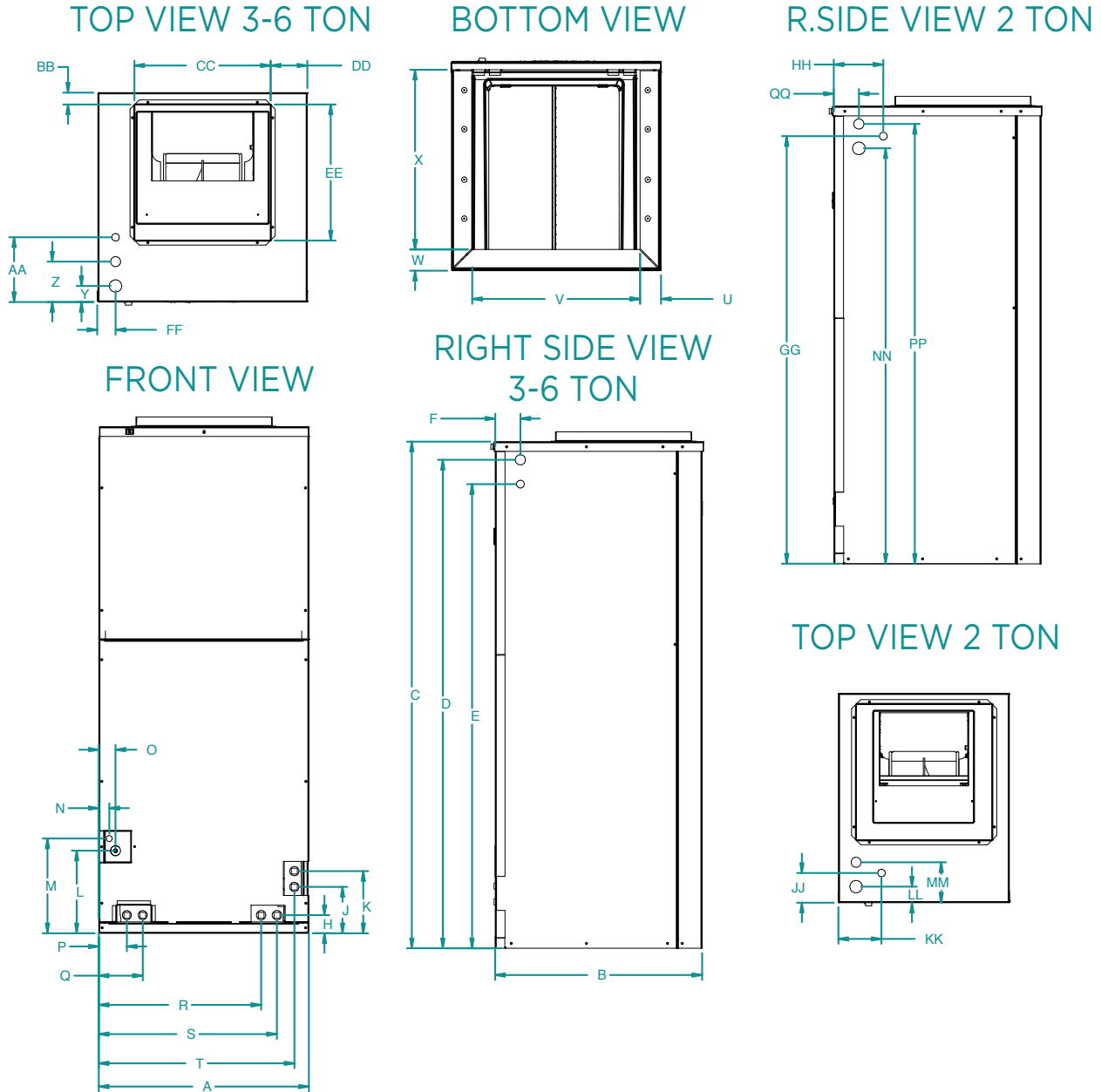

### SAH Air Handler - Topflow/Horizontal

Topflow/Horizontal Configuration	Overall Cabinet												Refrigerant Connections													024 CABINET DIMENSIONS ONLY																																			
	A	B	C	Condensate		F	H	J	K	Suction			Liquid			Gas			Oil			Y	Z	Low Voltage		AA	BB	CC	DD	EE	FF	GG	HH	JJ	KK	LL	MM	NN	PP	QQ																					
				3/4" cond	Power Supply					1/2" cond	Low Voltage	L	M	N	O	P	Q	R	S	T	U			V	W																X	Power Supply	Low Voltage																		
022-030	in.	17.5	21.2	47.0	42.6	45.1	2.5	1.9	4.8	6.4	8.8	10.1	1.1	1.7	2.9	4.5	13.0	14.6	16.2	2.1	13.3	2.1	18.4	1.7	3.1	4.1	1.1	14.0	1.8	14.0	1.8	43.9	5.1	3.0	4.4	1.7	4.2	42.6	45.1	2.5																					
	cm.	44.5	53.8	119.4	108.2	114.6	6.4	4.8	12.2	16.3	22.4	25.7	2.8	4.3	7.4	11.4	33.0	37.1	41.1	5.3	33.8	5.3	46.7	4.3	7.9	10.4	2.8	35.6	4.6	35.6	4.6	111.5	13.0	7.6	11.2	4.2	10.5	108.2	114.6	6.4																					
036	in.	21.6	21.2	52.0	50.1	47.6	2.6	1.9	4.8	6.4	8.5	9.7	1.1	1.7	2.9	4.5	16.7	18.3	20.1	2.2	17.2	2.2	18.5	1.6	4.2	6.7	1.2	14.0	3.8	14.0	1.9	54.9	53.8	132.1	127.3	120.9	6.6	4.7	12.1	16.3	21.6	24.6	2.8	4.4	7.3	11.4	42.4	46.5	51.1	5.5	43.8	5.6	46.9	4.1	10.5	16.9	3.0	35.5	9.6	35.5	4.8
	cm.	54.9	53.8	132.1	127.3	120.9	6.6	4.7	12.1	16.3	21.6	24.6	2.8	4.4	7.3	11.4	42.4	46.5	51.1	5.5	43.8	5.6	46.9	4.1	10.5	16.9	3.0	35.5	9.6	35.5	4.8	63.2	53.8	147.3	142.5	135.1	6.6	4.8	12.2	16.3	24.4	27.4	2.8	4.3	7.4	11.4	51.6	55.6	59.7	5.6	52.3	5.6	46.7	4.3	10.7	17.0	3.8	45.7	8.6	45.7	4.6
042-066	in.	24.9	21.2	58.0	56.1	53.2	2.6	1.9	4.8	6.4	9.6	10.8	1.1	1.7	2.9	4.5	20.3	21.9	23.5	2.2	20.6	2.2	18.4	1.7	4.2	6.7	1.5	18.0	3.4	18.0	1.8	63.2	53.8	147.3	142.5	135.1	6.6	4.8	12.2	16.3	24.4	27.4	2.8	4.3	7.4	11.4	51.6	55.6	59.7	5.6	52.3	5.6	46.7	4.3	10.7	17.0	3.8	45.7	8.6	45.7	4.6
	cm.	63.2	53.8	147.3	142.5	135.1	6.6	4.8	12.2	16.3	24.4	27.4	2.8	4.3	7.4	11.4	51.6	55.6	59.7	5.6	52.3	5.6	46.7	4.3	10.7	17.0	3.8	45.7	8.6	45.7	4.6																														

Condensate is plastic 3/4" FPT

Discharge flange is field installed and extends 1" (25.4 mm) from cabinet

\* "Y" IS 1 3/8 KNOCKOUT HIGH VOLTAGE  
 \* "Z" IS 1 1/8 KNOCKOUT HIGH VOLTAGE  
 \* "AA" IS 7/8 KNOCKOUT LOW VOLTAGE

# Dimensional Data - DX Air Handler

## Bottom Flow Unit Configuration

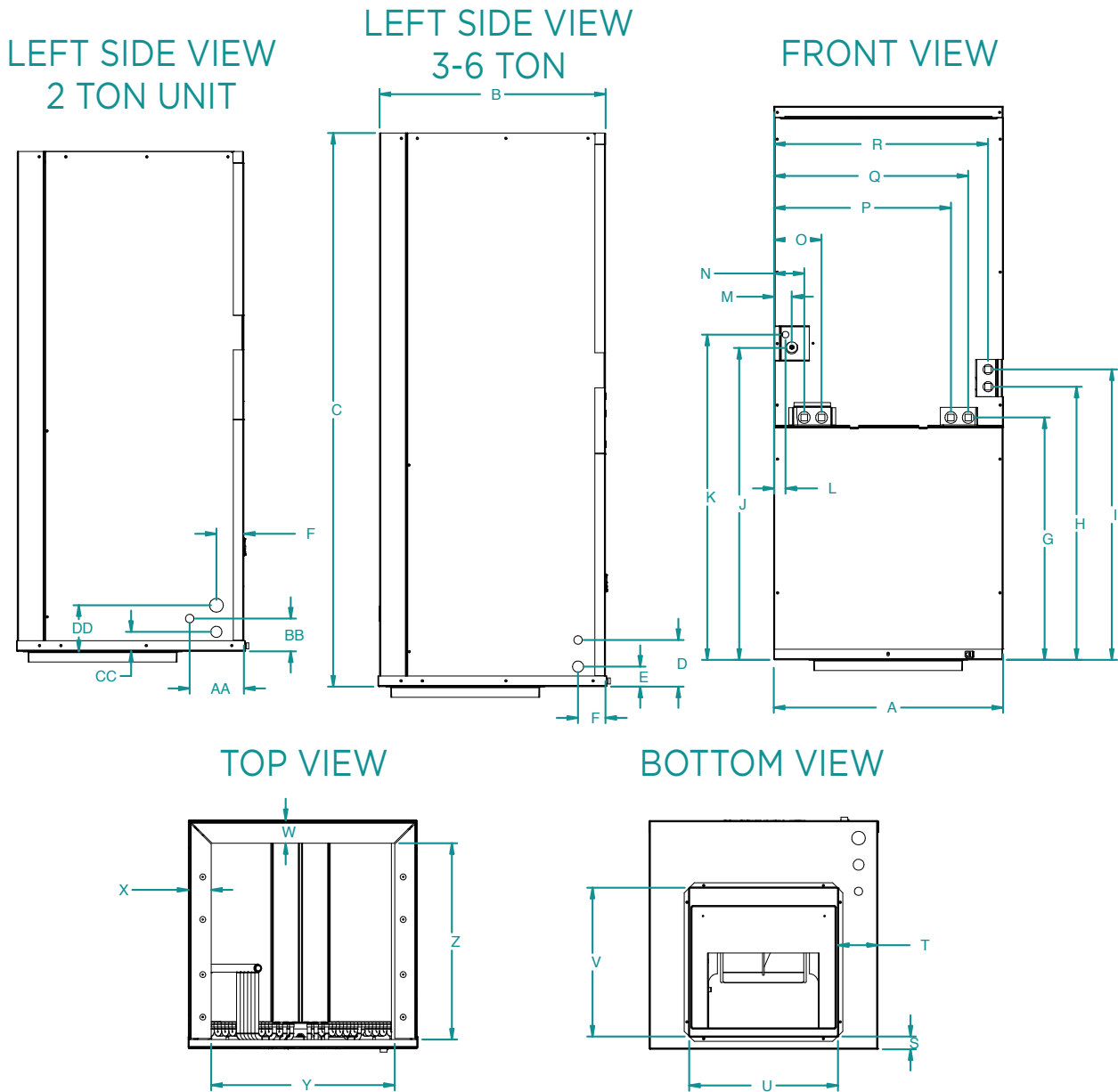

### SAH Air Handler - Bottom flow

Bottomflow Configuration	Overall Cabinet			Refrigerant Connections			POWER SUPPLY 024 ONLY																								
	A	B	C	D	E	F	G	H	I	J	K	L	M	N	O	P	Q	R	S	T	U	V	W	X	Y	Z	AA	BB	CC	DD	
				1/2" cond	3/4" cond	Low Voltage																									Power Supply
022-030	in.	17.5	21.2	47.0	4.4	1.9	2.5	22.8	25.7	27.3	29.5	30.8	1.1	1.7	2.8	4.5	13.0	14.5	16.2	1.1	1.8	14.0	18.0	2.2	2.2	13.7	18.5	5.0	3.1	1.8	4.3
	cm.	44.5	53.8	119.4	11.2	4.8	6.4	57.9	65.3	69.3	74.9	78.2	2.8	4.3	7.1	11.4	33.0	36.8	41.1	2.8	4.6	35.6	45.7	5.6	5.6	34.8	47.0	12.7	7.9	4.6	11.0
036	in.	21.5	21.2	52.0	4.4	1.9	2.6	22.8	25.7	27.3	29.3	30.6	1.1	1.7	2.8	4.5	16.6	18.2	20.1	1.2	3.8	14.0	14.0	2.2	2.2	17.3	18.5				
	cm.	54.6	53.8	132.1	11.2	4.8	6.6	57.9	65.3	69.3	74.5	77.7	2.7	4.3	7.2	11.4	42.2	46.3	51.1	3.0	9.7	35.6	35.6	5.6	5.6	43.8	46.9				
042-066	in.	24.9	21.2	58.0	4.4	1.9	2.6	24.0	27.0	28.5	31.3	32.8	1.1	1.7	2.8	4.5	20.2	21.9	23.5	1.2	3.4	18.0	18.0	2.1	2.2	20.5	18.5				
	cm.	63.2	53.8	147.3	11.2	4.8	6.6	61.0	68.6	72.4	79.5	83.3	2.8	4.3	7.1	11.4	51.3	55.6	59.7	3.0	8.6	45.7	45.7	5.3	5.6	52.1	47.0				

Condensate is plastic 3/4" FPT  
 Discharge flange is field installed and extends 1" (25.4 mm) from cabinet



## Electrical Data

Model	Electric Heat Capacity		Supply Circuit	Rated Voltage	Voltage Min/Max	Fan Motor FLA	Heater Ampacity		Total Unit FLA		Minimum Circuit Ampacity		Maximum Fuse/HACR			
	KW	BTUH					208v	240v	208v	240v	208v	240v	208v	240v	208v	240v
	240v	240v														
022	0	0	-	208-230/60/1	197/253	4.0	-	-	4.0	4.0	5.0	5.0	10	10		
	4.8	16,382	single			4.0	17.3	20.0	21.3	24.0	26.6	30.0	30	30		
026	0	0	-			4.0	-	-	4.0	4.0	5.0	5.0	10	10		
	4.8	16,382	single			4.0	17.3	20.0	21.3	24.0	26.6	30.0	30	30		
030	0	0	-			4.0	-	-	4.0	4.0	5.0	5.0	10	10		
	4.8	16,382	single			4.0	17.3	20.0	21.3	24.0	26.6	30.0	30	30		
036	0	0	-			4.0	-	-	4.0	4.0	5.0	5.0	10	10		
	4.8	16,382	single			4.0	17.3	20.0	21.3	24.0	26.6	30.0	30	30		
	9.6	32,765	single			4.0	34.7	40.0	38.7	44.0	48.4	55.0	50	60		
042	0	0	-			7.0	-	-	7.0	7.0	8.8	8.8	15	15		
	9.6	32,765	single			7.0	34.7	40.0	41.7	47.0	52.1	58.8	60	60		
	14.4	49,147	single			7.0	52.0	60.0	59.0	67.0	73.8	83.8	80	90		
	14.4	49,147	L1/L2 L3/L4			7.0	34.7	40.0	41.7	47.0	52.1	58.8	60	60		
048	0	0	-			-	17.3	20.0	17.3	20.0	21.6	25.0	25	25		
	9.6	32,765	single			7.0	-	-	7.0	7.0	8.8	8.8	15	15		
	14.4	49,147	single			7.0	34.7	40.0	41.7	47.0	52.1	58.8	60	60		
	14.4	49,147	L1/L2 L3/L4			7.0	52.0	60.0	59.0	67.0	73.8	83.8	80	90		
060	0	0	-			-	17.3	20.0	17.3	20.0	21.6	25.0	25	25		
	9.6	32,765	single			7.0	-	-	7.0	7.0	8.8	8.8	15	15		
	14.4	49,147	single			7.0	34.7	40.0	41.7	47.0	52.1	58.8	60	60		
	14.4	49,147	L1/L2 L3/L4			7.0	52.0	60.0	59.0	67.0	73.8	83.8	80	90		
	19.2	65,530	single			7.0	34.7	40.0	41.7	47.0	52.1	58.8	60	60		
	19.2	65,530	L1/L2 L3/L4			7.0	52.0	60.0	59.0	67.0	73.8	83.8	80	90		
	19.2	65,530	single			7.0	69.3	80.0	76.3	87.0	95.4	108.8	100	110		
066	0	0	-	7.0	34.7	40.0	41.7	47.0	52.1	58.8	60	60				
	9.6	32,765	single	7.0	34.7	40.0	41.7	47.0	52.1	58.8	60	60				
	14.4	49,147	single	7.0	52.0	60.0	59.0	67.0	73.8	83.8	80	90				
	14.4	49,147	L1/L2 L3/L4	7.0	34.7	40.0	41.7	47.0	52.1	58.8	60	60				
	19.2	65,530	single	-	17.3	20.0	17.3	20.0	21.6	25.0	25	25				
	19.2	65,530	L1/L2 L3/L4	7.0	69.3	80.0	76.3	87.0	95.4	108.8	100	110				
	19.2	65,530	single	7.0	34.7	40.0	41.7	47.0	52.1	58.8	60	60				
	19.2	65,530	L1/L2 L3/L4	-	34.7	40.0	34.7	40.0	43.4	50.0	50	50				

Rev.  
Rated Voltage of 208/230/60/1  
HACR circuit breaker in USA only

1/10/17

## Compatibility

### Air Handler Sizing Selection

The Air Handlers are designed for R-410A refrigerant and should be matched with split compressor section according to the table below.

Air Handler	Indoor Split Model (Single)	Indoor Split Model (Dual Capacity)	Outdoor Split Model (Dual Capacity)	Rated Airflow(CFM)	Electric Heat (kW)
SAH022***1*R1S1*	022	-	-	800	5
SAH026***1*R1S1*	-	026	026	850	5
SAH030***1*R1S1*	030	-	-	1000	5
SAH036***1*R1S1*	036	-	-	1200	5, 10
SAH036***1*R1S1*	-	038	038	1200	5, 10
SAH042***1*R1S1*	042	-	-	1300	10, 15
SAH048***1*R1S1*	048	-	-	1500	10, 15
SAH048***1*R1S1*	-	049	049	1500	10, 15
SAH060***1*R1S1*	060	-	-	1800	10, 15, 20
SAH060***1*R1S1*	-	064	064	1800	10, 15, 20
SAH066***1*R1S1*	070	-	-	2000	10, 15, 20
SAH066***1*R1S1*	-	072	072	2000	10, 15, 20

1/31/2017

# Wiring Schematics

## SAH Air Handler Control Option A Schematic

97P901-01

Air Handler No Electric Heat

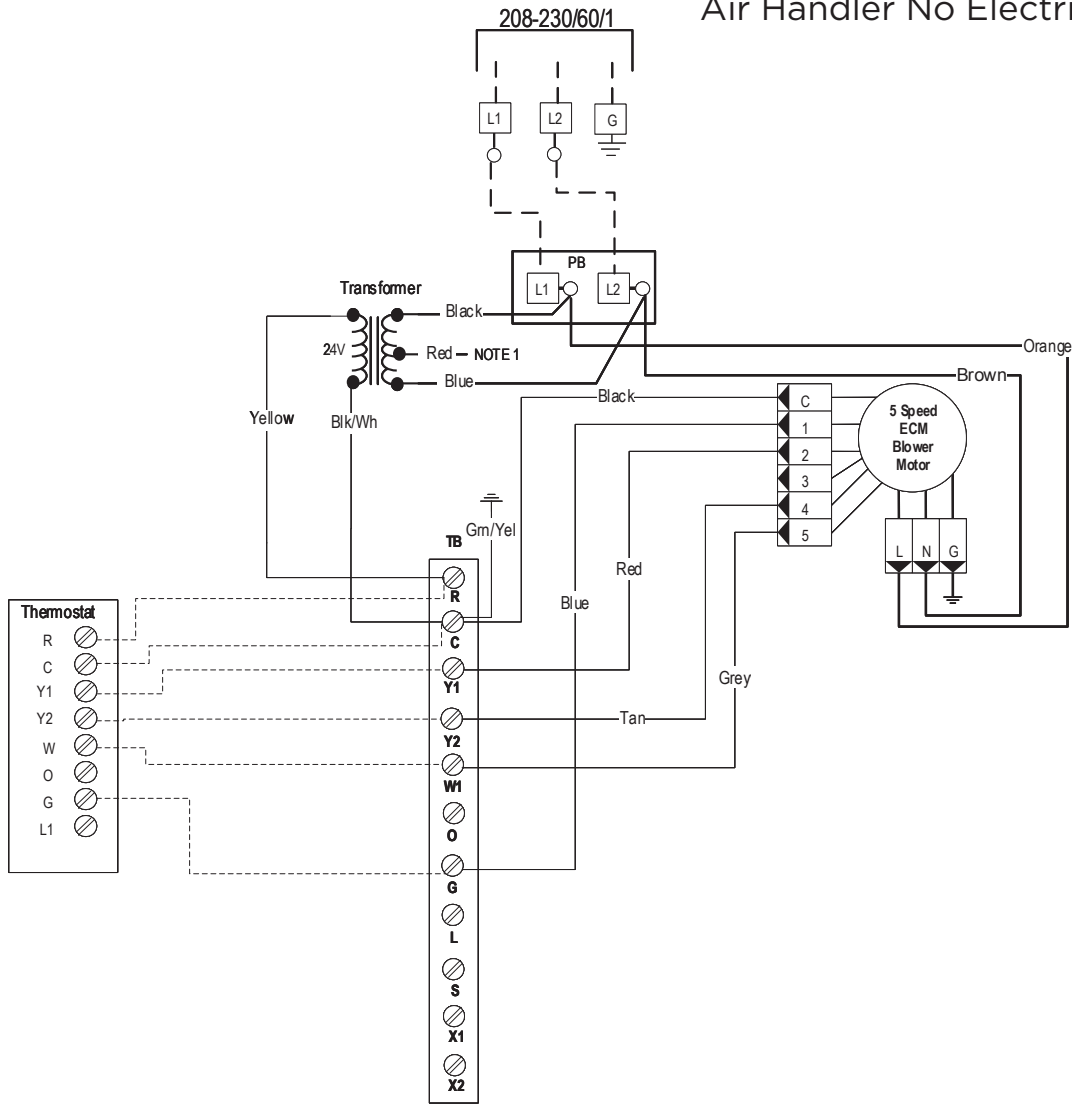

**Notes:**  
 1 – To operate in 208V mode replace the blue transformer wire connected to PB-L2 with red transformer wire.  
 2 – Low voltage wiring CLASS 2.

Legend	
	Factory Low voltage wiring
	Factory Line voltage wiring
	Field low voltage wiring
	Field line voltage wiring
	Optional block
	DC Voltage PCB traces
	Internal junction
	Quick connect terminal
	Thermal Limit Switch
	Field wire lug
	Ground
	N.O., N.C.
	Light emitting diode - Green
	Fused Limit
	Breaker
	Polarized connector
	Power block
	DIP package 4 position
	Heater element
	Current Transducer

# Wiring Schematics cont.

## SAH Air Handler Control Option A Schematic

97P901-02

### Air Handler 5kW Electric Heat

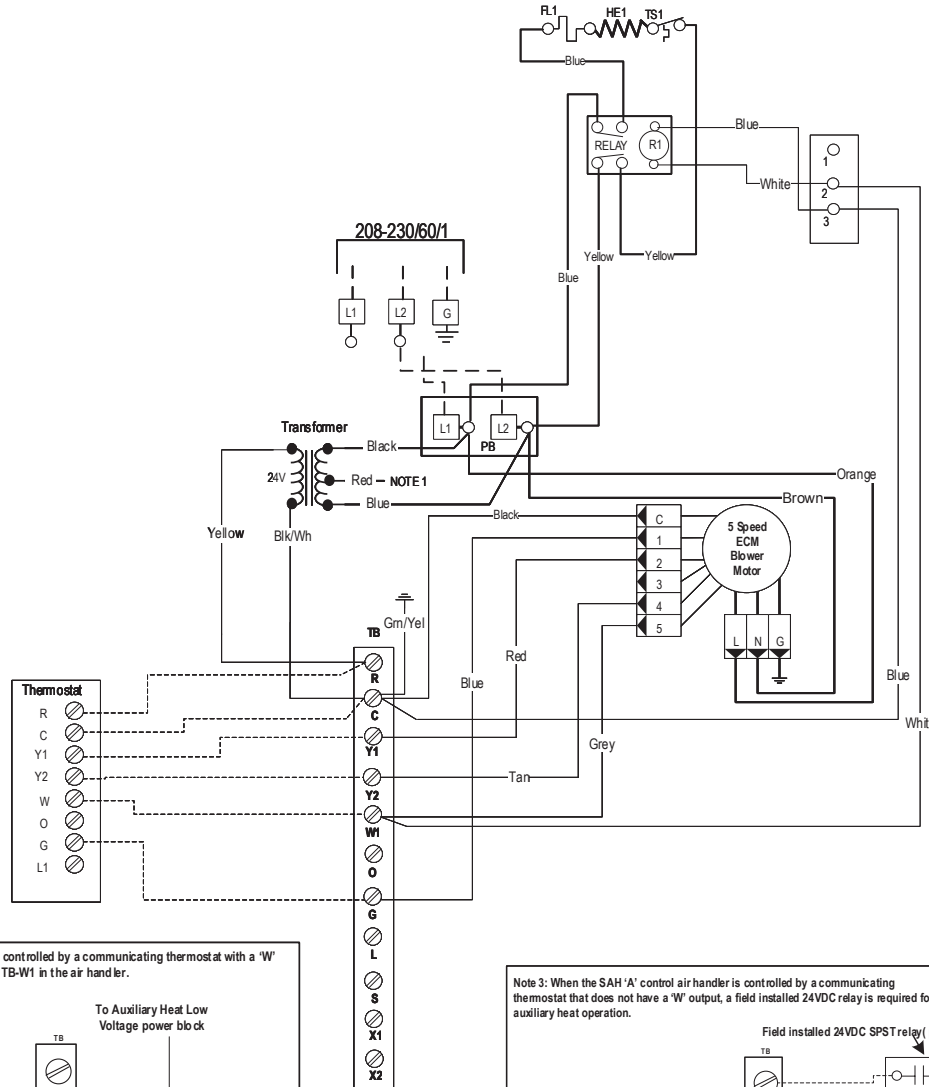

Note 4: When the SAH 'A' control air handler is controlled by a communicating thermostat with a 'W' output. The 'W' output should be connected to TB-W1 in the air handler.

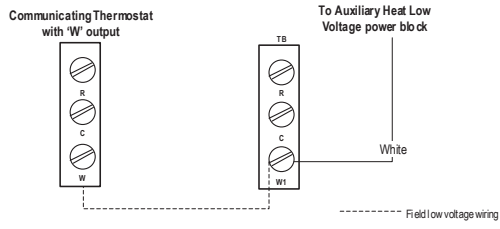

Note 3: When the SAH 'A' control air handler is controlled by a communicating thermostat that does not have a 'W' output, a field installed 24VDC relay is required for auxiliary heat operation.

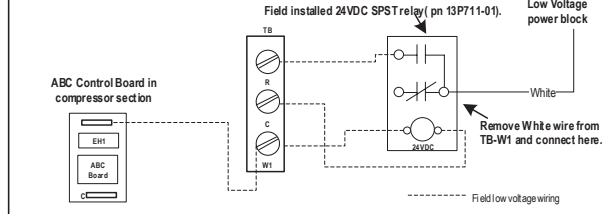

- Notes:**
- To operate in 208V mode replace the blue transformer wire connected to PB-L2 with red transformer wire.
  - Low voltage wiring CLASS 2.
  - When the SAH 'A' control air handler is controlled by a communicating thermostat a field installed 24VDC relay is required for auxiliary heat operation.
  - When the SAH 'A' control air handler is controlled by a communicating thermostat with a 'W' output. The 'W' output should be connected to TB-W1 in the air handler.

Legend	
	Factory Low voltage wiring
	Factory Line voltage wiring
	Field low voltage wiring
	Field line voltage wiring
	Optional block
	DC Voltage PCB traces
	Internal junction
	Quick connect terminal
	Thermal Limit Switch
	Field wire lug
	Ground
	N.O., N.C.
	Light emitting diode - Green
	Fused Limit
	Breaker
	Polarized connector
	Power block
	DIP package 4 position
	Heater element
	Current Transducer

# Wiring Schematics cont.

## SAH Air Handler Control Option A Schematic

97P901-03

### Air Handler 10kW Electric Heat

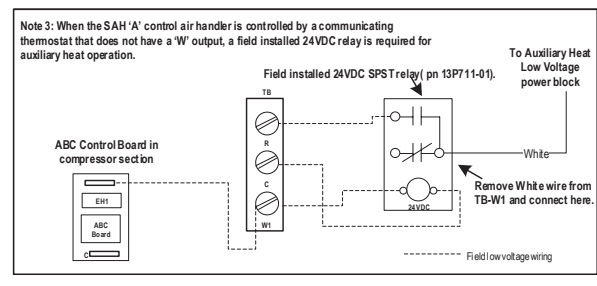
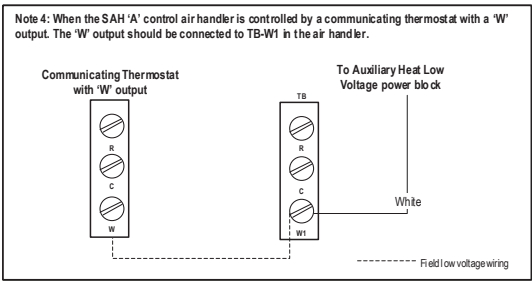
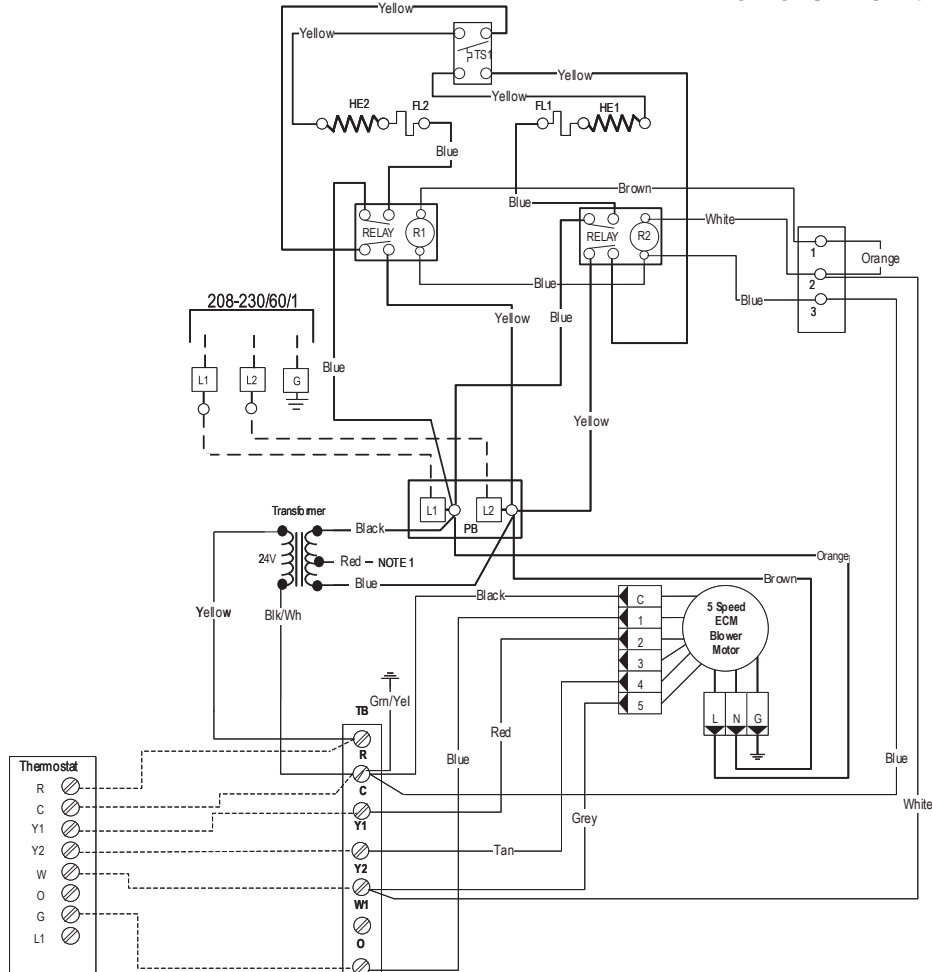

- Notes:**
- 1 - To operate in 208V mode replace the blue transformer wire connected to PB-L2 with red transformer wire.
  - 2 - Low voltage wiring CLASS 2.
  - 3 - When the SAH 'A' control air handler is controlled by a communicating thermostat a field installed 24VDC relay is required for auxiliary heat operation.
  - 4 - When the SAH 'A' control air handler is controlled by a communicating thermostat with a 'W' output. The 'W' output should be connected to TB-W1 in the air handler.

**Legend**

—	Factory Low voltage wiring	⊗	Light emitting diode - Green
—	Factory Line voltage wiring	FL	Fused Limit
---	Field low voltage wiring	⎓	Breaker
---	Field line voltage wiring	⏏	Polarized connector
---	Optional block	PB -	Power block
---	DC Voltage PCB traces	SW1 -	DIP package 4 position
●	Internal junction	HE -	Heater element
○	Quick connect terminal	■	Current Transducer
TS	Thermal Limit Switch		
L1	Field wire lug		
⏏	Ground		
⎓	N.O., N.C.		

# Wiring Schematics cont.

## SAH Air Handler Control Option A Schematic

97P901-04

### Air Handler 15kW Electric Heat

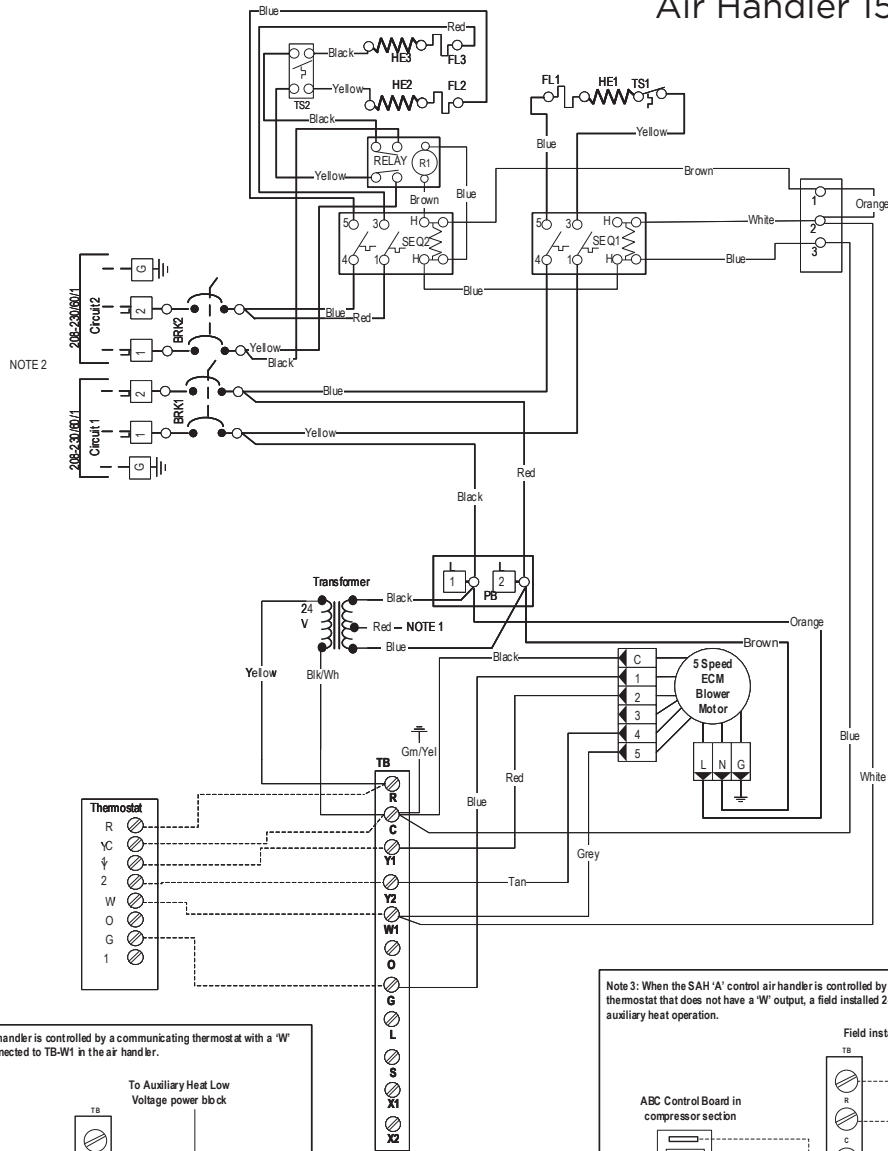

NOTE 2

Note 4: When the SAH 'A' control air handler is controlled by a communicating thermostat with a 'W' output. The 'W' output should be connected to TB-W1 in the air handler.

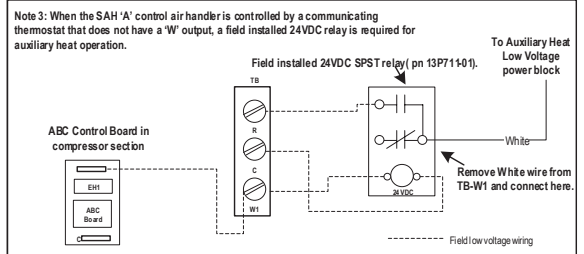
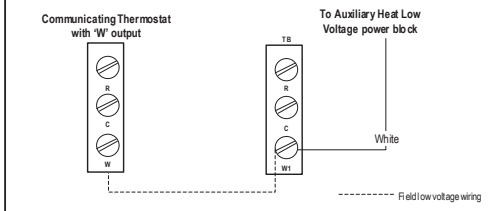

- Notes:**
- 1 - To operate in 208V mode replace the blue transformer wire connected to PB-L2 with red transformer wire.
  - 2 - Use manufacturer's part number 19P52-01 (jumper bar assembly) when single source power is required.
  - 3 - Low voltage wiring CLASS 2.
  - 4 - When the SAH 'A' control air handler is controlled by a communicating thermostat a field installed 24VDC relay is required for auxiliary heat operation.
  - 5 - When the SAH 'A' control air handler is controlled by a communicating thermostat with a 'W' output. The 'W' output should be connected to TB-W1 in the air handler.

Legend			
	Factory Low voltage wiring		Light emitting diode - Green
	Factory Line voltage wiring		Fused Limit
	Field low voltage wiring		Breaker
	Field line voltage wiring		Polarized connector
	Optional block		Power block
	DC Voltage PCB traces		DIP package 4 position
	Internal junction		Heater element
	Quick connect terminal		Current Transducer
	Thermal Limit Switch		
	Field wire lug		
	Ground		
	N.O., N.C.		

**Dual Power Supply Connections**

If two separate circuits are used to supply power to the auxiliary heat kit, the Installer will need to verify that each leg of the auxiliary heat circuit breakers are wired from the power supply correctly in order for the electric heat kit to operate properly. This can be done by measuring the supply side voltage of the auxiliary heat circuit breakers. Put a voltmeter on the L2 side of Circuit Breaker One and on the L2 side of Circuit Breaker Two. The voltmeter should read approximately 0 volts. If the meter reads high voltage, the auxiliary heat breakers need to be rewired so that breakers in the auxiliary heat kit match the wiring of the Disconnect Panel breakers. Meaning, L1 and L2 from one breaker in the disconnect panel must connect to L1 and L2 at one of the auxiliary heat circuit breakers and L1 and L2 from the other breaker in the disconnect panel must connect to L1 and L2 of the other auxiliary heat circuit breaker, making sure that the L1 and L2 from each disconnect breaker matches the L1 and L2 at each of the auxiliary heat breakers.

# Wiring Schematics cont.

## SAH Air Handler Control Option A Schematic

97P901-05

Air Handler 20kW Electric Heat

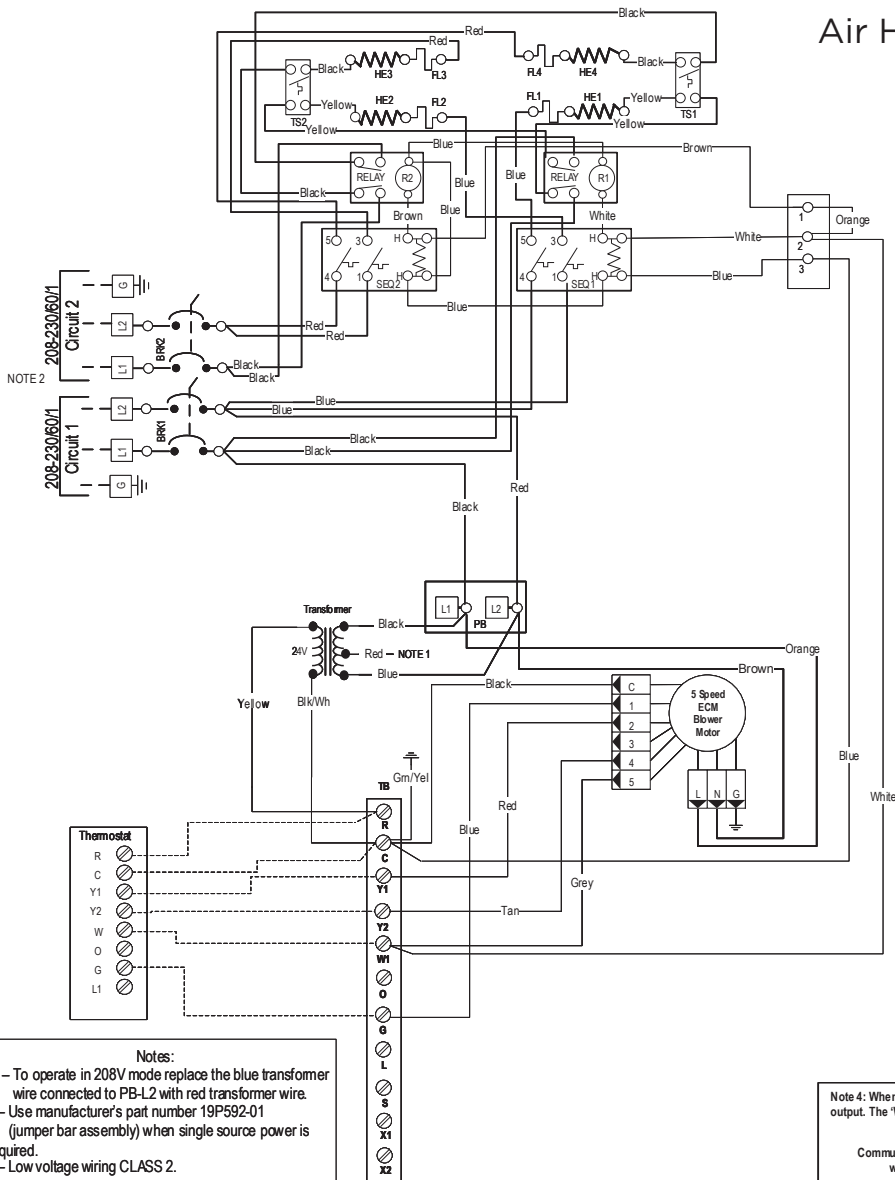

- Notes:**
- 1 - To operate in 208V mode replace the blue transformer wire connected to PB-L2 with red transformer wire.
  - 2 - Use manufacturer's part number 19P592-01 (jumper bar assembly) when single source power is required.
  - 3 - Low voltage wiring CLASS 2.
  - 4 - When the SAH 'A' control air handler is controlled by a communicating thermostat a field installed 24VDC relay is required for auxiliary heat operation.
  - 5 - When the SAH 'A' control air handler is controlled by a communicating thermostat with a 'W' output. The 'W' output should be connected to TB-W1 in the air handler.

**Legend**

	Factory Low voltage wiring		Light emitting diode - Green
	Factory Line voltage wiring		Fused Limit
	Field low voltage wiring		Breaker
	Field line voltage wiring		Polarized connector
	Optional block		Power block
	DC Voltage PCB traces		DIP package 4 position
	Internal junction		Heater element
	Quick connect terminal		Current Transducer
	Thermal Limit Switch		
	Field wire lug		
	Ground		
	N.O., N.C.		

**Dual Power Supply Connections**

If two separate circuits are used to supply power to the auxiliary heat kit, the Installer will need to verify that each leg of the auxiliary heat circuit breakers are wired from the power supply correctly in order for the electric heat kit to operate properly. This can be done by measuring the supply side voltage of the auxiliary heat circuit breakers. Put a voltmeter on the L2 side of Circuit Breaker One and on the L2 side of Circuit Breaker Two. The voltmeter should read approximately 0 volts. If the meter reads high voltage, the auxiliary heat breakers need to be rewired so that breakers in the auxiliary heat kit match the wiring of the Disconnect Panel breakers. Meaning, L1 and L2 from one breaker in the disconnect panel must connect to L1 and L2 at one of the auxiliary heat circuit breakers and L1 and L2 from the other breaker in the disconnect panel must connect to L1 and L2 of the other auxiliary heat circuit breaker, making sure that the L1 and L2 from each disconnect breaker matches the L1 and L2 at each of the auxiliary heat breakers.

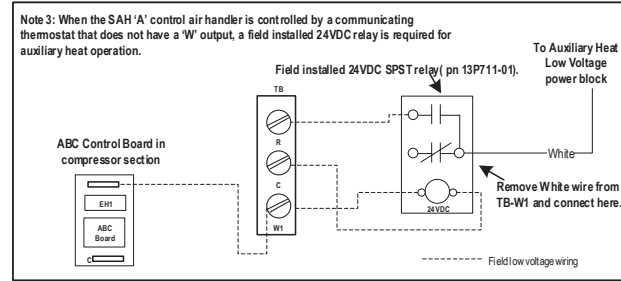
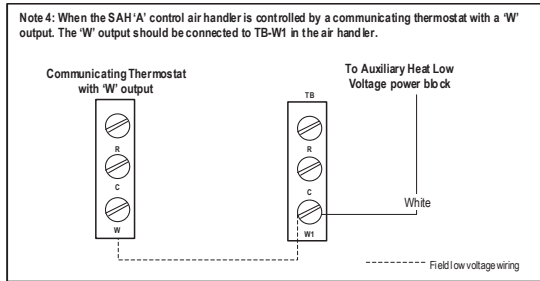

# Wiring Schematics cont.

## SAH Air Handler Control Option C Schematic

97P903-01

Air Handler No Electric Heat

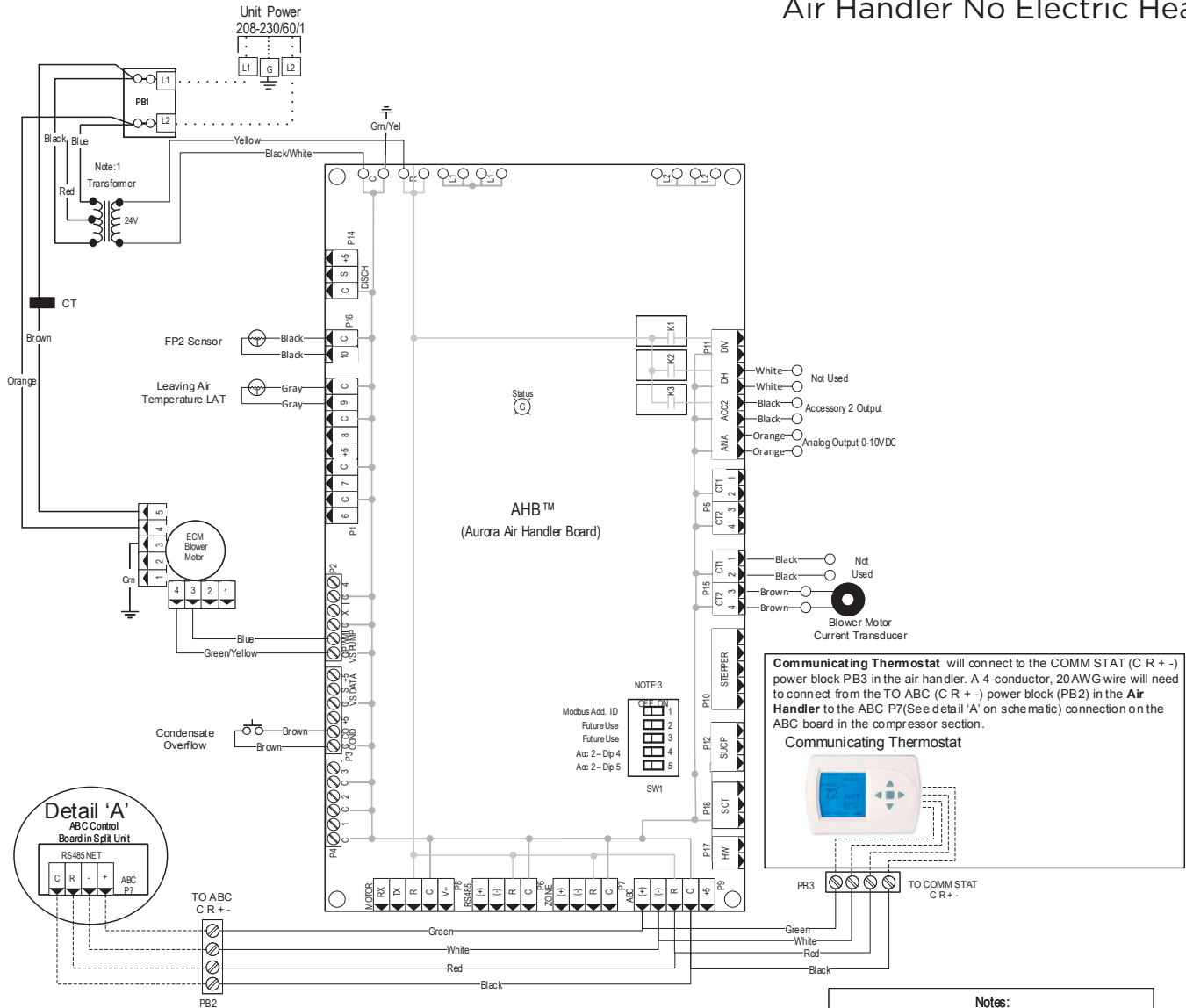

**Communicating Thermostat** will connect to the COMM STAT (C R +) power block PB3 in the air handler. A 4-conductor, 20AWG wire will need to connect from the TO ABC (C R +) power block (PB2) in the **Air Handler** to the ABC P7 (See detail 'A' on schematic) connection on the ABC board in the compressor section.

**Communicating Thermostat**

**Note: On the AID Tool Configure Aurora Screen, confirm the AHB is added and communicating.**

- Notes:**
- 1 - To operate in 208V mode replace the blue transformer wire connected to PB1-L2 with red transformer wire.
  - 2 - Low voltage wiring CLASS 2.
  - 3 - DIP switch 1 on SW1 must be set in the OFF position.

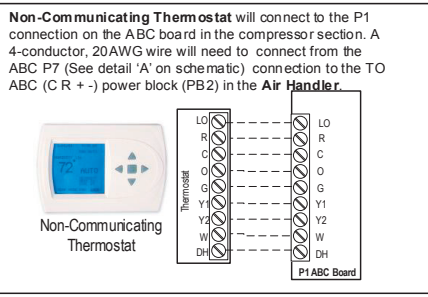

**Legend**

	Factory Low voltage wiring		Light emitting diode - Green
	Factory Line voltage wiring		Fused Limit
	Field low voltage wiring		Breaker
	Field line voltage wiring		Polarized connector
	Optional block		Power block
	DC Voltage PCB traces		DIP package 4 position
	Internal junction		Heater element
	Quick connect terminal		Current Transducer
	Thermal Limit Switch		
	Field wire lug		
	Ground		
	N.O., N.C.		

# Wiring Schematics cont.

## SAH Air Handler Control Option C Schematic

97P903-02

### Air Handler 5kW Electric Heat

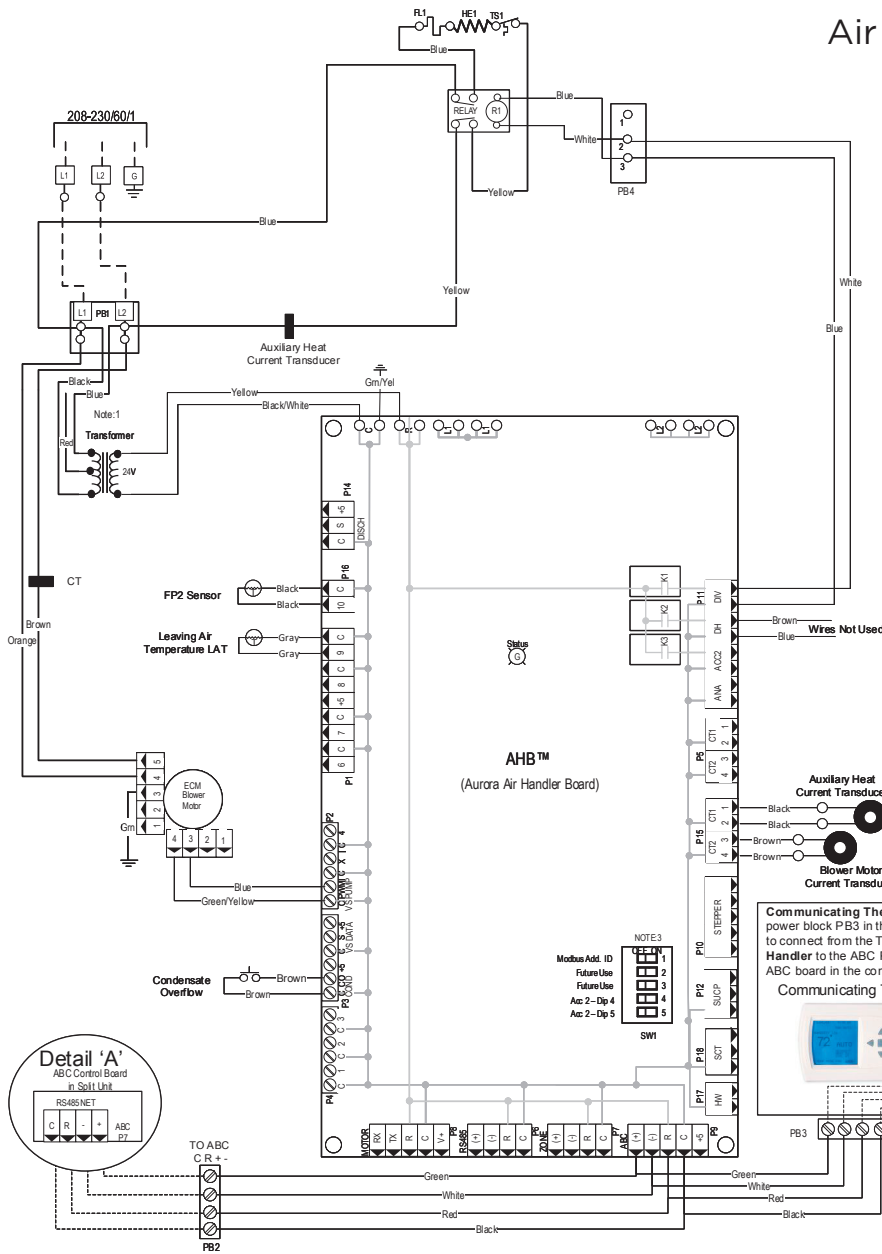

**Note: On the AID Tool Configure Aurora Screen, confirm the AHB is added and communicating.**

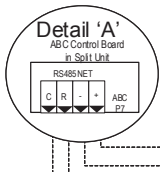
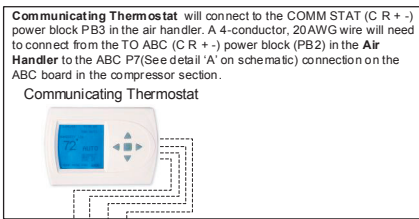

**Notes:**  
 1 – To operate in 208V mode replace the blue transformer wire connected to PB1-L2 with red transformer wire.  
 2 – Low voltage wiring CLASS 2.  
 3 – DIP switch 1 on SW1 must be set in the OFF position.

Legend	
	Factory Low voltage wiring
	Factory Line voltage wiring
	Field low voltage wiring
	Field line voltage wiring
	Optional block
	DC Voltage PCB traces
	Internal junction
	Quick connect terminal
	Thermal Limit Switch
	Field wire lug
	Ground
	N.O., N.C.
	Light emitting diode - Green
	Fused Limit
	Breaker
	Polarized connector
	Power block
	DIP package 4 position
	Heater element
	Current Transducer

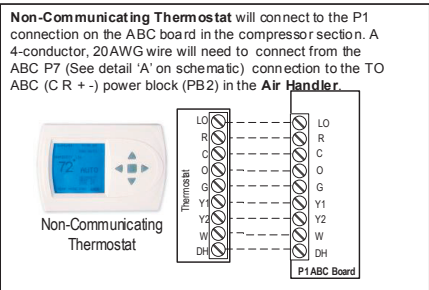



# Wiring Schematics cont.

## SAH Air Handler Control Option C Schematic

97P903-03

### Air Handler 10kW Electric Heat

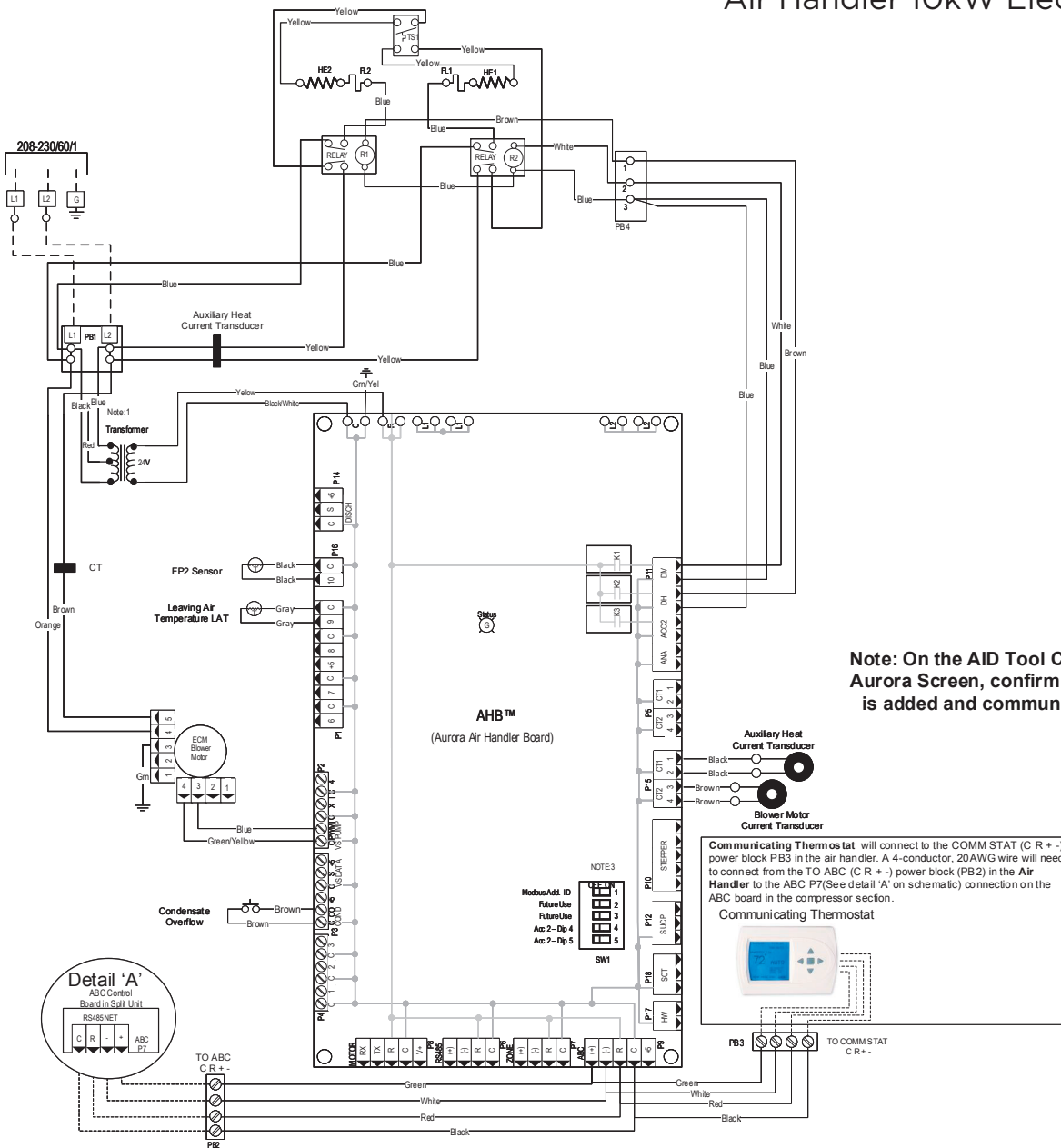

**Note: On the AID Tool Configure Aurora Screen, confirm the AHB is added and communicating.**

Communicating Thermostat will connect to the COMM STAT (C R + -) power block PB3 in the air handler. A 4-conductor, 20AWG wire will need to connect from the TO ABC (C R + -) power block (PB2) in the Air Handler to the ABC P7 (See detail 'A' on schematic) connection on the ABC board in the compressor section.

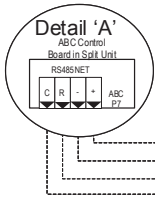

- Notes:**
- 1 - To operate in 208V mode replace the blue transformer wire connected to PB1-L2 with red transformer wire.
  - 2 - Low voltage wiring CLASS 2.
  - 3 - DIP switch 1 on SW1 must be set in the OFF position.

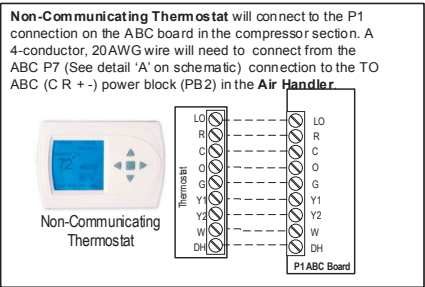

**Legend**

	Factory Low voltage wiring		Light emitting diode - Green
	Factory Line voltage wiring		Fused Limit
	Field low voltage wiring		Breaker
	Field line voltage wiring		Polarized connector
	Optional block		Power block
	DC Voltage PCB traces		DIP package 4 position
	Internal junction		Heater element
	Quick connect terminal		Current Transducer
	Thermal Limit Switch		
	Field wire lug		
	Ground		
	N.O., N.C.		

# Wiring Schematics cont.

## SAH Air Handler Control Option C Schematic

97P903-04

### Air Handler 15kW Electric Heat

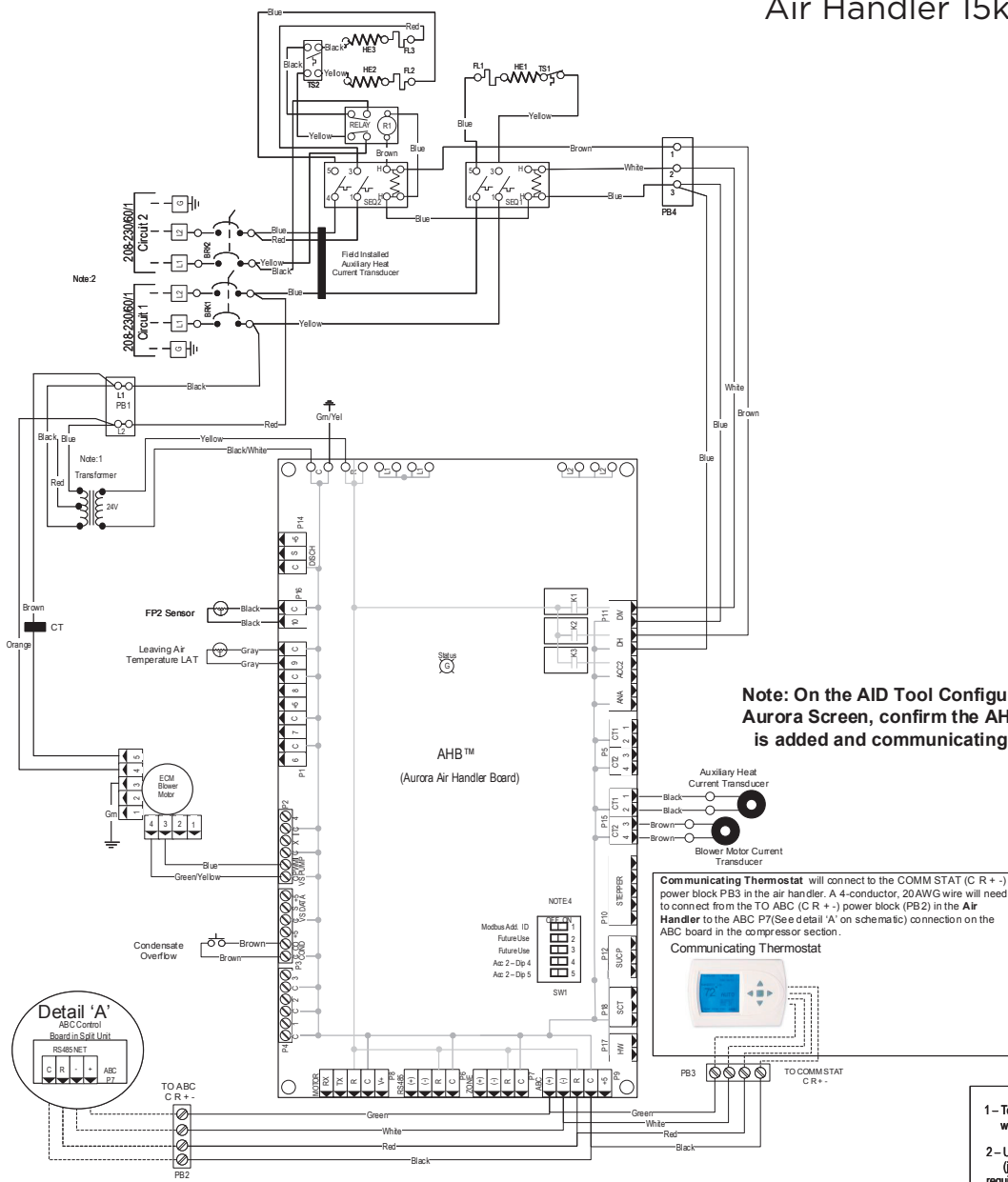

**Note: On the AID Tool Configure Aurora Screen, confirm the AHB is added and communicating.**

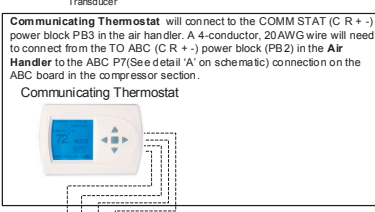

- Notes:**
- 1 - To operate in 208V mode replace the blue transformer wire connected to PB1-L2 with red transformer wire.
  - 2 - Use manufacturer's part number 19P592-01 (jumper bar assembly) when single source power is required.
  - 3 - Low voltage wiring CLASS 2.
  - 4 - DIP switch 1 on SW1 must be set in the OFF position.

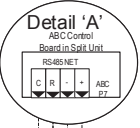

**Legend**

	Factory low voltage wiring		Light emitting diode - Green
	Factory line voltage wiring		Fused Limit
	Field line voltage wiring		Breaker
	Optional block		Polarized connector
	DC Voltage PCB traces		Power block
	Internal junction		DIP package 4 position
	Quick connect terminal		Heater element
	Thermal Limit Switch		Current Transducer
	Field wire lug		
	Ground		
	N.O., N.C.		

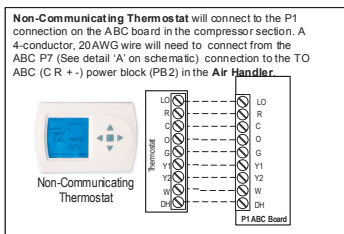

**Dual Power Supply Connections**

If two separate circuits are used to supply power to the auxiliary heat kit, the installer will need to verify that each leg of the auxiliary heat circuit breakers are wired from the power supply correctly in order for the electric heat kit to operate properly. This can be done by measuring the supply side voltage of the auxiliary heat circuit breakers. Put a voltmeter on the L2 side of Circuit Breaker One and on the L2 side of Circuit Breaker Two. The voltmeter should read approximately 0 volts. If the meter reads high voltage, the auxiliary heat breakers need to be rewired so that breakers in the auxiliary heat kit match the wiring of the Disconnect Panel breakers. Meaning, L1 and L2 from one breaker in the disconnect panel must connect to L1 and L2 at one of the auxiliary heat circuit breakers and L1 and L2 from the other breaker in the disconnect panel must connect to L1 and L2 of the other auxiliary heat circuit breaker, making sure that the L1 and L2 from each disconnect breaker matches the L1 and L2 at each of the auxiliary heat breakers.

# Wiring Schematics cont.

## SAH Air Handler Control Option C Schematic

97P903-05

### Air Handler 20kW Electric Heat

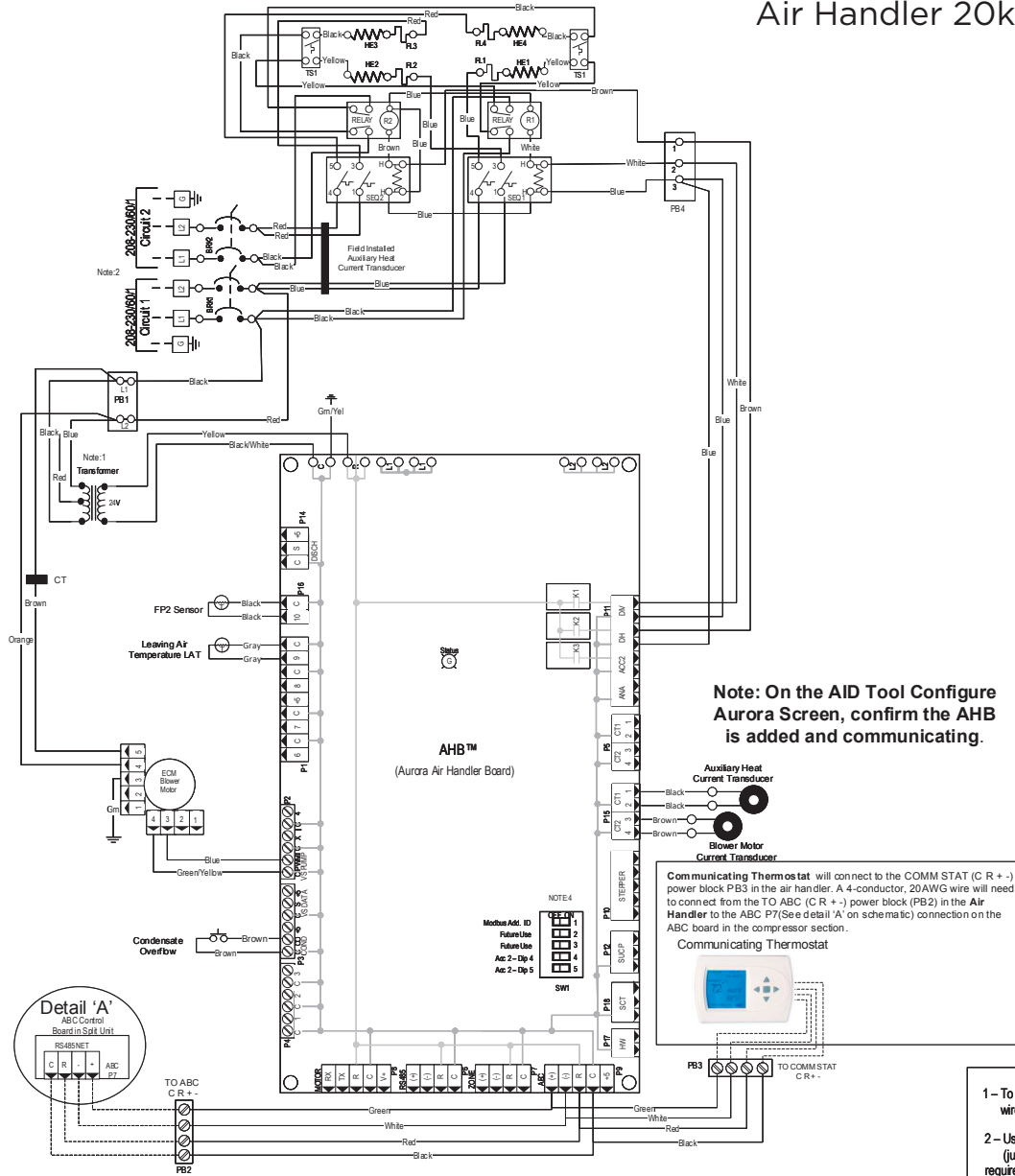

**Note: On the AID Tool Configure Aurora Screen, confirm the AHB is added and communicating.**

Communicating Thermostat will connect to the COMM STAT (C R + -) power block PB3 in the air handler. A 4-conductor, 20AWG wire will need to connect from the TO ABC (C R + -) power block (PB2) in the Air Handler to the ABC P7 (See detail 'A' on schematic) connection on the ABC board in the compressor section.

- Notes:**
- 1 - To operate in 208V mode replace the blue transformer wire connected to PB1-L2 with red transformer wire.
  - 2 - Use manufacturer's part number 19P592-01 (jumper bar assembly) when single source power is required.
  - 3 - Low voltage wiring CLASS 2.
  - 4 - DIP switch 1 on SW1 must be set in the OFF position.

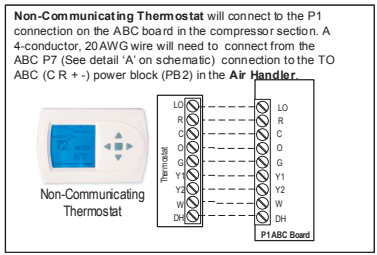
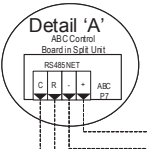

**Legend**

—	Factory Low voltage wiring	○	Light emitting diode - Green
—	Factory Line voltage wiring	FL	Fused Limit
---	Field low voltage wiring	□	Breaker
---	Field line voltage wiring	□	Polarized connector
---	Optional block	□	Power block
---	DC Voltage PCB traces	□	DIP package 4 position
●	Internal junction	HE -	Heater element
○	Quick connect terminal	■	Current Transducer
○	Thermal Limit Switch		
⊥	Field wire lug		
⊥	Ground		
⊥	N.O., N.C.		

**Dual Power Supply Connections**

If two separate circuits are used to supply power to the auxiliary heat kit, the Installer will need to verify that each leg of the auxiliary heat circuit breakers are wired from the power supply correctly in order for the electric heat kit to operate properly. This can be done by measuring the supply side voltage of the auxiliary heat circuit breakers. Put a voltmeter on the L2 side of Circuit Breaker One and on the L2 side of Circuit Breaker Two. The voltmeter should read approximately 0 volts. If the meter reads high voltage, the auxiliary heat breakers need to be rewired so that breakers in the auxiliary heat kit match the wiring of the Disconnect Panel breakers. Meaning, L1 and L2 from one breaker in the disconnect panel must connect to L1 and L2 at one of the auxiliary heat circuit breakers and L1 and L2 from the other breaker in the disconnect panel must connect to L1 and L2 of the other auxiliary heat circuit breaker, making sure that the L1 and L2 from each disconnect breaker matches the L1 and L2 at each of the auxiliary heat breakers.

# SAH 5 Speed ECM Blower Performance Data Option A

## Blower Performance 5 Speed ECM Control Option A

Model	Motor Speed	Motor Tap	T'stat Connection	Blower Size	Motor HP	Airflow (cfm) at External Static Pressure (in. wg)															
						0	0.05	0.10	0.15	0.20	0.25	0.30	0.35	0.40	0.45	0.50	0.60	0.70	0.80	0.90	1.00
022	High	5	W	9 x 7	1/2	1130	1115	1100	1090	1080	1065	1050	1040	1030	1015	1000	980	950	-	-	-
	Med High	4	Y2*			1040	1025	1010	1000	990	975	960	945	930	915	900	880	850	-	-	-
	Med	3				950	935	920	905	890	875	860	845	830	815	800	760	730	-	-	-
	Med Low	2	Y1			860	845	830	815	800	785	770	755	740	720	700	660	590	-	-	-
	Low	1	G			740	720	700	680	660	645	630	605	580	540	500	460	-	-	-	-
026	High	5	W	9 x 7	1/2	1130	1115	1100	1090	1080	1065	1050	1040	1030	1015	1000	980	950	-	-	-
	Med High	4	Y2*			1040	1025	1010	1000	990	975	960	945	930	915	900	880	850	-	-	-
	Med	3				950	935	920	905	890	875	860	845	830	815	800	760	730	-	-	-
	Med Low	2	Y1			860	845	830	815	800	785	770	755	740	720	700	660	590	-	-	-
	Low	1	G			740	720	700	680	660	645	630	605	580	540	500	460	-	-	-	-
030	High	5	W	9 x 7	1/2	1220	1205	1190	1180	1170	1160	1150	1140	1130	1115	1100	1050	930	-	-	-
	Med High	4	Y2*			1130	1115	1100	1090	1080	1070	1060	1045	1030	1015	1000	980	950	-	-	-
	Med	3				1040	1030	1020	1005	990	975	960	945	930	915	900	890	850	-	-	-
	Med Low	2	Y1			950	935	920	905	890	875	860	845	830	815	800	770	730	-	-	-
	Low	1	G			790	770	750	735	720	700	680	660	640	620	600	530	500	-	-	-
036	High	5	W	10 x 8	1/2	1450	1435	1420	1405	1390	1375	1360	1345	1330	1315	1300	1270	1250	1210	-	-
	Med High	4	Y2*			1350	1335	1320	1305	1290	1275	1260	1245	1230	1215	1200	1170	1140	1100	-	-
	Med	3	Y1			1170	1150	1130	1115	1100	1080	1060	1045	1030	1015	1000	960	920	880	-	-
	Med Low	2				1000	980	960	940	920	905	890	870	850	825	800	760	710	650	-	-
	Low	1	G			990	915	840	800	760	730	700	680	660	630	600	520	470	430	-	-
042	High	5	W	11 x 10	1	1960	1945	1930	1915	1900	1880	1860	1845	1830	1810	1790	1750	1700	1660	-	-
	Med High	4	Y2*			1790	1775	1760	1745	1730	1710	1690	1670	1650	1535	1420	1560	1500	1450	-	-
	Med	3				1700	1685	1670	1650	1630	1615	1600	1575	1550	1525	1500	1450	1400	1350	-	-
	Med Low	2	Y1			1630	1560	1600	1520	1560	1535	1510	1490	1470	1445	1420	1370	1300	1250	-	-
	Low	1	G			1490	1445	1400	1375	1350	1325	1300	1270	1240	1210	1180	1120	1000	930	-	-
048	High	5	W	11 x 10	1	1960	1945	1930	1915	1900	1880	1860	1845	1830	1810	1790	1750	1700	1660	1600	-
	Med High	4	Y2*			1790	1775	1760	1745	1730	1710	1690	1670	1650	1535	1420	1560	1500	1450	1450	-
	Med	3				1700	1685	1670	1650	1630	1615	1600	1575	1550	1525	1500	1450	1400	1350	1350	-
	Med Low	2	Y1			1630	1560	1600	1520	1560	1535	1510	1490	1470	1445	1420	1370	1300	1250	1250	-
	Low	1	G			1490	1445	1400	1375	1350	1325	1300	1270	1240	1210	1180	1120	1000	930	930	-
060	High	5	W	11 x 10	1	2210	2230	2190	2194	2170	2155	2130	2120	2100	2087	2060	2020	2000	1960	1920	1890
	Med High	4	Y2*			2030	2073	2000	2035	1970	1995	1940	1958	1910	1922	1870	1840	1800	1760	1720	1680
	Med	3				1850	1931	1820	1889	1790	1850	1760	1812	1730	1774	1680	1640	1600	1560	1510	1450
	Med Low	2	Y1			1770	1796	1740	1761	1710	1718	1680	1682	1630	1651	1590	1560	1500	1450	1400	1340
	Low	1	G			1570	1661	1540	1616	1510	1573	1460	1533	1420	1495	1370	1320	1250	1200	1100	1020
066	High	5	W	11 x 10	1	2390	2454	2370	2414	2340	2371	2320	2328	2290	2289	2270	2230	2200	2170	2140	2100
	Med High	4	Y2*			2210	2248	2180	2205	2160	2166	2140	2129	2100	2094	2070	2040	2000	1960	1940	1890
	Med	3	Y1			2030	2115	2010	2072	1980	2030	1950	1996	1900	1965	1880	1840	1800	1760	1720	1680
	Med Low	2				1860	1985	1830	1939	1800	1898	1770	1862	1730	1828	1690	1640	1600	1570	1510	1460
	Low	1	G			1780	1784	1750	1742	1720	1696	1680	1656	1640	1625	1600	1550	1500	1460	1400	1380

Factory speed settings are in Bold

Air flow values are with dry coil and standard filter

For wet coil performance first calculate the face velocity of the air coil (Face Velocity [fpm] = Airflow [cfm] / Face Area [sq ft]).

Then for velocities of 200 fpm reduce the static capability by 0.03 in. wg, 300 fpm by 0.08 in. wg, 400 fpm by 0.12in. wg., and 500 fpm by 0.16 in. wg.

Highest setting is for auxiliary heat (W) and lowest setting is for constant blower (G). The "Y1" and "Y2" settings must be between the "G" and "W" settings.

**\*Single speed compressor section units will need to remove the TAN wire on the 5 speed motor and replace it with the RED wire. Tape end and secure the TAN wire.**

**The SAH Air Handler blower is factory wired for dual speed compressor section operation.**

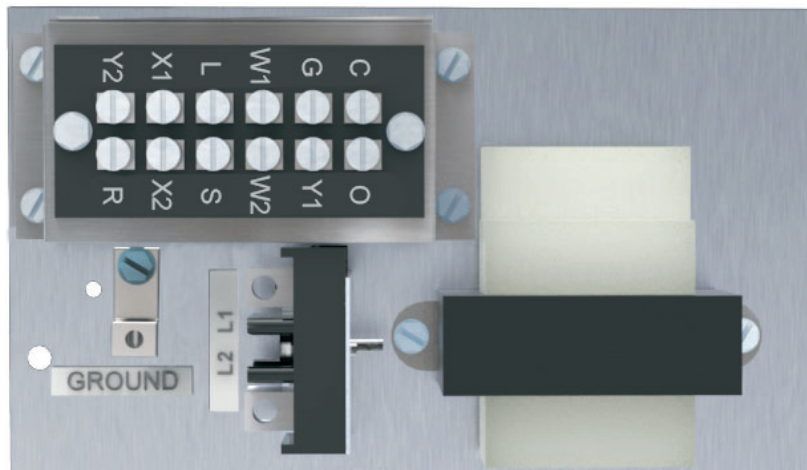

## SAH 5 Speed ECM Blower Performance Data Option A cont.

### 5-Speed ECM Constant Torque Motors

The 5-Speed ECM is a 'Constant Torque' ECM motor and delivers air flow similar to a PSC but operates as efficiently as an ECM Motor. Because it's an ECM Motor, the 5-Speed ECM can ramp slowly up to down like the ECM motor. There are 5 possible speed taps available on the 5-Speed ECM motor with #1 being the lowest airflow and #5 being the highest airflow. These speed selections are preset at the time of manufacture and are easily changed in the field if necessary.

If more than one tap are energized at the same time, built in logic gives precedence to the highest tap number and allows air flow to change with G, Y1, Y2 and W signals. Each of those 5 speeds has a specific 'Torque' value programmed into the motor for each speed selection. As static pressure increases, airflow decreases resulting in less torque on the rotor. The motor responds only to changes in torque and adjusts its speed accordingly.

The 5-Speed ECM motor is powered by line voltage but the motor speed is energized by 24 VAC.

#### 5-Speed ECM Benefits:

- High Efficiency
- Soft Start
- 5 speeds with up to 4 speeds on-line
- Built-in logic allows air flow to change with G, Y1, Y2 and W signals
- Super efficient low airflow continuous blower setting.

### Setting Blower Speed - 5-Speed ECM

5-Speed ECM blower motors have five (5) speeds of which three (3) are selectable on single speed and four (4) are selectable on dual capacity.



**Caution: Disconnect all power before performing this operation.**

#### 5-Speed ECM Motor Connections - Single Speed Splits

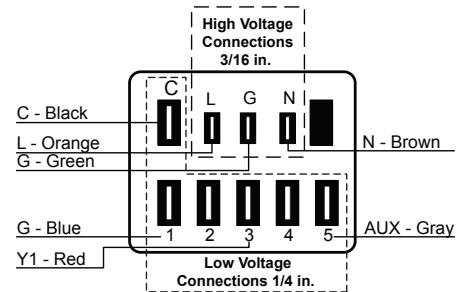

#### 5-Speed ECM Motor Connections - Dual Capacity Splits

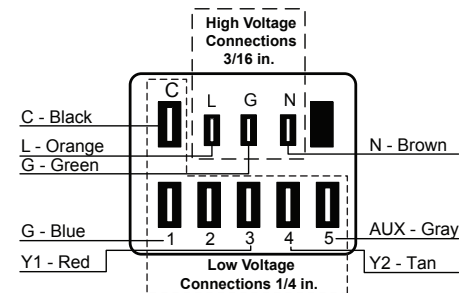

# Blower Performance Data Option C

## Blower Performance Variable Speed ECM Control Option C

MODEL	MAX ESP	AIR FLOW SPEED SETTINGS											
		1	2	3	4	5	6	7	8	9	10	11	12
022	0.50		400	500 G	<b>600 L</b>	700	800 H	900	1000 Aux	1100	1200		
026	0.50		400	500 G	600	700 L	800	900 H	<b>1000 Aux</b>	1100	1200		
030	0.50		400	500 G	600	700 L	800	900 H	1000 Aux	1100	1200		
036	0.50	550	650	700 G	<b>800</b>	850	900	950 L	1050	1100 H	1200	1300 Aux	
042	0.75	650	750	800	900 G	1000	1150	1200 L	1300	1400 H	1500	1600	1700 Aux
048	0.75	650	750	800	900 G	1000	1150	1200	1300 L	1400	1500 H	1600	1700 Aux
060	0.75	950	1100 G	1200	<b>1350</b>	1500	1650 L	1700	1800 H	2000 Aux	2100	2200	
066	0.75	950	1100 G	1200	<b>1350</b>	1500	1650 L	1700	1800	2000 H	2100 Aux	2200	

Factory settings are at recommended G-L-H-Aux speed settings

1/10/17

L-H settings MUST be located within boldface CFM range

"Aux" is factory setting for auxiliary/emergency heat and must be equal to or above the "H" setting as well as at least the minimum required for the auxiliary heat package

"G" may be located anywhere within the airflow table

CFM is controlled within 5% up to the maximum ESP

Max ESP includes allowance for wet coil.

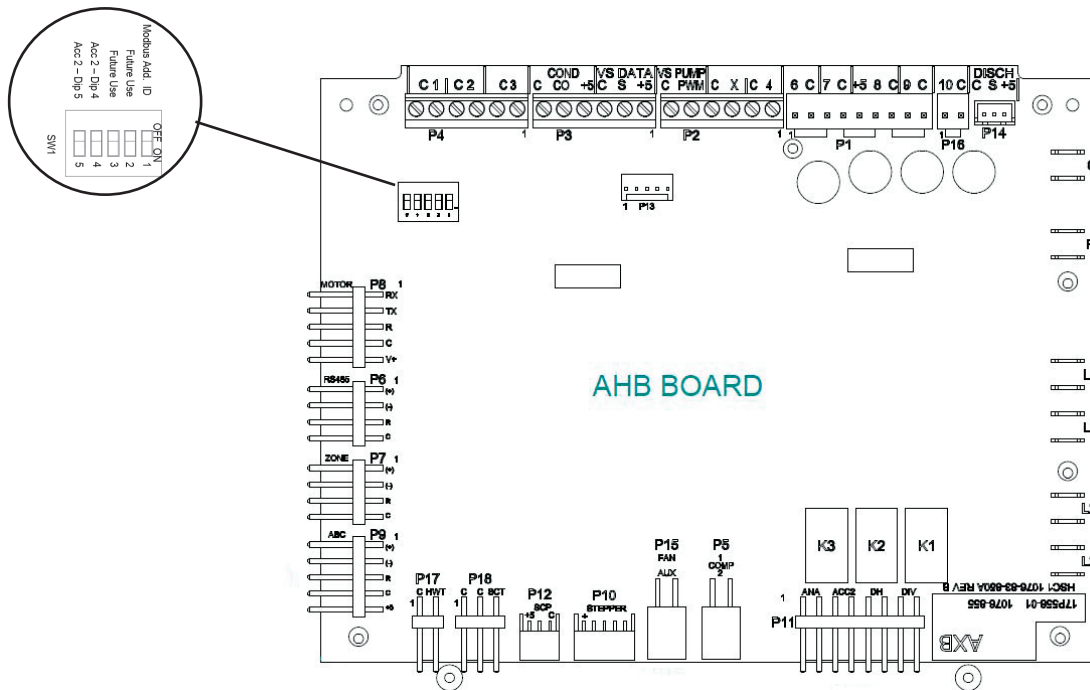

## Blower Performance Data Option C cont.

### SAH Control Option C AHB Board

The SAH Air Handler with the 'Advanced' control option expands on the capability of the Aurora 'Advanced' Control (ABC and AXB) in the compressor section, by adding the AHB board in the air handler.

**NOTE: The Energy Monitoring and Leaving Air Temperature features at the AHB board are dependent on the AXB board in the compressor section.**

It is highly recommended that the installing/servicing contractor use an Aurora Interface and Diagnostic Tool (AID) when installing and servicing an Aurora 'Advanced' control system.

The AHB board includes the following features:

#### AHB DIP Switch

**DIP 1 - ID:** This is the AHB ModBus ID and should always read Off.

#### DIP 2 & 3 - Future Use

**DIP 4 & 5 - Accessory Relay2:** A second, DIP configurable, accessory relay is provided that can be cycled with the compressor 1 or 2, blower, or the Dehumidifier (DH) input. This is to complement the Accessory 1 Relay on the ABC board.

Position	DIP 4	DIP 5	Description
1	ON	ON	Cycles with Fan or ECM (or G)
2	OFF	ON	Cycles with CC1 first stage of compressor or compressor spd 1-6
3	ON	OFF	Cycles with CC2 second stage of compressor or compressor spd 7-12
4	OFF	OFF	Cycles with DH input from ABC board

### IntelliZone2 Zoning Compatibility (Optional IntelliZone2 Communicating Zoning)

A dedicated input to connect and communicate with the IntelliZone2 (IZ2) zoning system is provided on P7 on the AHB and AXB. This is a dedicated communication port using a proprietary ModBus protocol. An AXB in the compressor section or an AHB in the air handler is required. Consult the IntelliZone2 literature for more information.

### Communicating Digital Thermostats

The Aurora controls system also features either mono-chromatic or color touch screen graphic display thermostats for user interface. These displays not only feature easy to use graphical interface but display alerts and faults in plain English. Many of the features discussed here may not be applicable without these thermostats.

### Energy Monitoring (AXB Board Required in Compressor Section) (Standard Sensor Kit on 'Advanced' models)

The Energy Monitoring Kit includes two current transducers (blower and electric heat) so that the complete power usage of the air handler can be measured. The AID Tool provides configuration detail for the type of blower motor, power adjustment and a line voltage calibration procedure to improve the accuracy. The information can be displayed on the AID Tool or selected communicating thermostats. The TPCM32U03A(\*)/04A(\*) will display instantaneous energy use while the color touchscreen TPCC32U01(\*) will in addition display a 13 month history in graph form. Refer to Compressor Section Start Up Energy Monitoring for configuration details.

**Freeze Detection (Air Coil)** – uses the FP2 input to protect against ice formation on the air coil. The FP2 input will operate exactly like FP1 except that the set point is 30 degrees and is not field adjustable.

**Condensate Overflow** – fault is recognized when the impedance between this line and 24 VAC common or chassis ground drops below 100K ohms for 30 seconds continuously.

### Leaving Air Temperature (AXB Board Required in Compressor Section)

A leaving air temperature (LAT) thermistor is located near the blower inlet and can be read via the AID tool.

### Electric Heat Staging

The AHB board provides two stages of auxiliary heat operation. During normal operation, the first stage of electric heat is energized 10 seconds after the W command is received. If the demand continues the second stage of electric heat will be energized after 5 minutes. In an Emergency heat operation the time delay between stage one and stage two will be 2 minutes.

## Blower Performance Data Option C cont.

### Setting Blower Speed - Variable Speed ECM

The ABC board's Yellow Config LED will flash the current ECM blower speed selections for "G", low, and high continuously with a short pause in between. The speeds can also be confirmed with the AID Tool under the Setup/ECM Setup screen. The Aux will not be flashed but can be viewed in the AID Tool. The ECM blower motor speeds can be field adjusted with or without using an AID Tool.

#### ECM Setup without an AID Tool

The blower speeds for "G", Low (Y1), High (Y2), and Aux can be adjusted directly at the Aurora ABC board which utilizes the push button (SW1) on the ABC board. This procedure is outlined in the ECM Configuration Mode portion of the Aurora 'Base' Control System section. The Aux cannot be set manually without an AID Tool.

#### ECM Setup with an AID Tool

A much easier method utilizes the AID Tool to change the airflow using the procedure below. First navigate to the Setup screen and then select ECM Setup. This screen displays the current ECM settings. It allows the technician to enter the setup screens to change the ECM settings. Change the highlighted item using the ◀ and ▶ buttons and then press the ⏏ button to select the item.

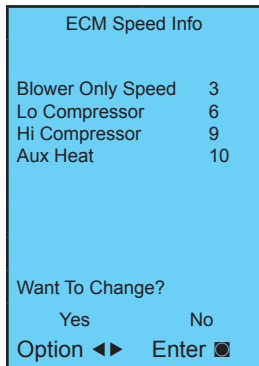

Selecting YES will enter ECM speed setup, while selecting NO will return to the previous screen.

**ECM Speed Setup** - These screens allow the technician to select the "G", low, high, and auxiliary heat blower speed for the ECM blower motor. Change the highlighted item using the ▲ and ▼ buttons. Press the ⏏ button to select the speed.

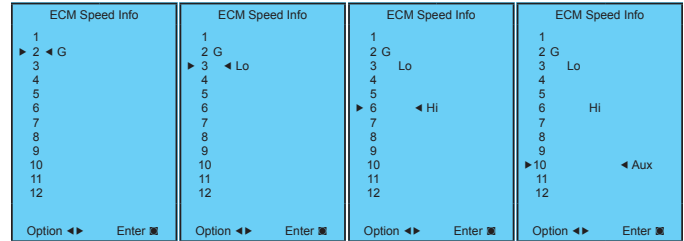

After the auxiliary heat speed setting is selected the AID Tool will automatically transfer back to the ECM Setup screen.

**Cooling Airflow Setup** - These screens allow the technician to select -15%, -10%, -5%, None or +5%. Change the adjustment percentage using the ▲ and ▼ buttons. Press the ⏏ button to save the change.

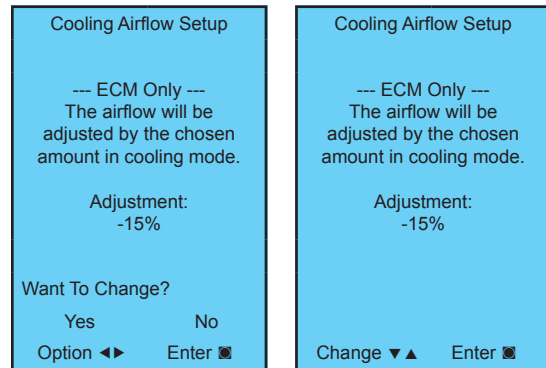



## SR Encased/Uncased Nomenclature

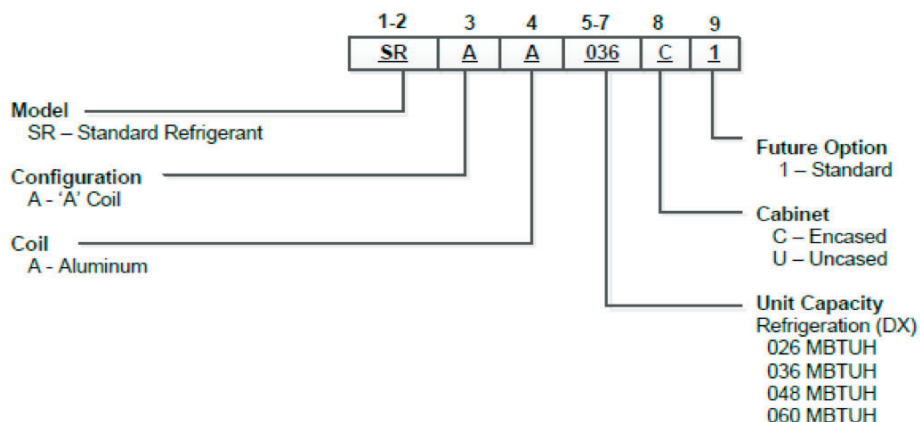

## Refrigerant Coil Compatibility

Encased/Uncased Coil	Indoor Split Model (Single)	Indoor Split Model (Dual Capacity)	Outdoor Split Model (Dual Capacity)	Recommended Airflow (CFM)
SR**026C*	022	-		800
SR**026C*	-	026	026	850
SR**026C*	030	-	-	1000
SR**036C*	036	-	-	1200
SR**036C*	-	038	038	1200
SR**048C*	042	-	-	1300
SR**048C*	048	-	-	1500
SR**048C*	-	049	049	1500
SR**060C*	060	-	-	1800
SR**060C*	-	064	064	1800
SR**060C*	070	-	-	2000
SR**060C*	-	072	072	2000

3/7/2017

## SR Coil Physical Characteristics

Air Handler Model Number (Refrigerant)		026			036		048		060	
<b>Evaporator Coil</b>	Air Coil Total Face Area, ft2 [m2]	3.89 [0.36]			4.86 [0.45]		5.83 [0.54]		6.81 [0.63]	
	Tube outside diameter - in. [mm]	3/8 [9.52]								
	Number of rows	3								
	Fins per inch	12								
	Suction line connection - in. [mm] sweat	5/8 [15.87]			3/4 [19.05]			7/8 [22.23]		
	Liquid line connection - in. [mm] sweat	3/8 [9.52]						1/2 [12.7]		
Refrigerant	R-410a									
Nominal cooling capacity - tons [kW]	1.8 [6.44]	2.1 [7.59]	2.5 [8.79]	3 [10.55]	3.5 [12.30]	4 [14.06]	5 [17.58]	5.5 [19.33]		
Condensate drain connection - (FPT) in. [mm]	3/4 [19.05]									
Filter Standard - 1" [51mm] Field Supplied.	16 X 20 [406 X 508]			20 X 20 [508 X 508]			22 X 20 [559 X 508]			

3/7/17

## Dimensional Data

### Refrigerant Coil

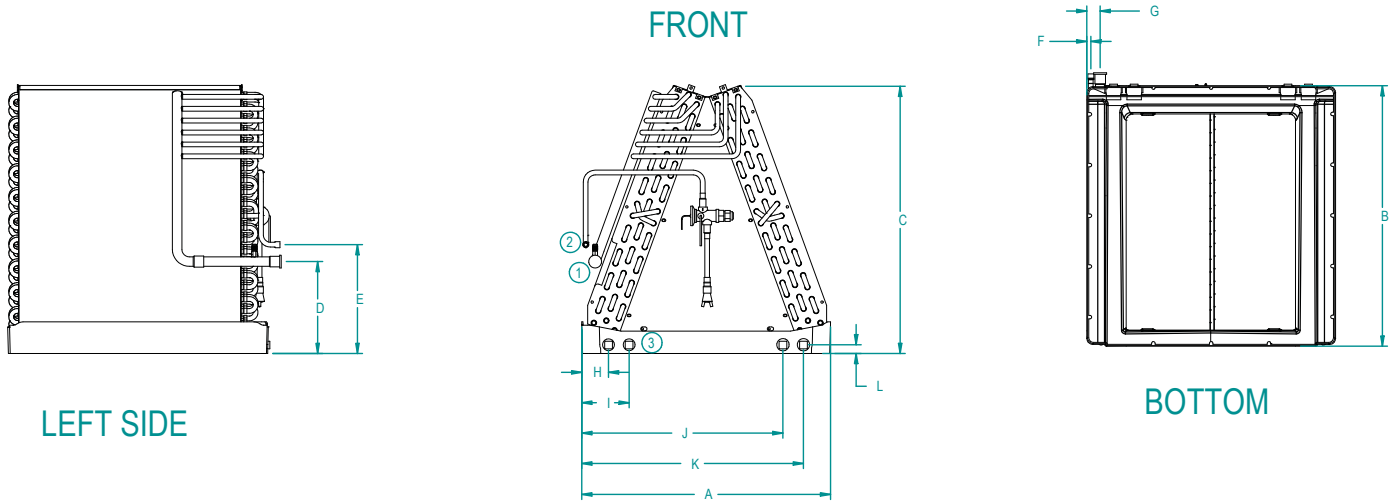

### SR UNCASSED AIR COIL

Uncased Models	Overall Dimensions			Connections			Refrigerant Connections				Condensate Connections					
	A	B	C	1	2	3	D	E	F	G	H	I	J	K	L	
	Width	Depth	Height*	Suction Sweat	Liquid Sweat	Condensate NPT										
SRAA026U*	in.	16.1	20.7	17.5	5/8	3/8	3/4	7.7	8.9	0.3	0.8	2.0	3.6	12.3	13.9	0.7
	cm.	40.8	52.6	44.5	1.6	1.0	1.9	19.4	22.5	0.8	1.9	5.1	9.1	31.2	35.3	1.8
SRAA036U*	in.	19.7	20.7	21.1	3/4	3/8	3/4	7.2	8.6	0.3	1.1	2.1	3.8	15.9	17.5	0.7
	cm.	50.0	52.6	53.6	1.9	1.0	1.9	18.2	21.8	0.8	2.7	5.4	9.5	40.4	44.5	1.8
SRAA048U*	in.	23.2	20.7	24.9	3/4	3/8	3/4	8.4	9.6	0.2	0.9	2.1	3.8	19.5	21.0	0.7
	cm.	58.9	52.6	63.2	1.9	1.0	1.9	21.3	24.4	0.4	2.3	5.3	9.7	49.5	53.3	1.8
SRAA060U*	in.	23.2	20.7	29.4	7/8	1/2	3/4	8.5	9.8	0.3	0.9	2.1	3.8	19.5	21.0	0.7
	cm.	58.9	52.6	74.6	2.2	1.3	1.9	21.6	24.9	0.8	2.2	5.3	9.7	49.5	53.3	1.8

\*NOTE: All refrigerant coils feature factory installed TXV.

### SR Cased Coil Air Side Pressure Drop (inches of WC)

Model	Airflow (CFM)	Dry Coil
SRAA026C1	600	0.08
	800	0.14
	1000	0.20
SRAA036C1	1000	0.11
	1200	0.14
	1400	0.18
SRAA048C1	1200	0.12
	1400	0.15
	1600	0.19
	1800	0.25
SRAA060C1	1600	0.21
	1800	0.27
	2000	0.33
	2200	0.38

3/7/2017

## Dimensional Data - DX Cased Coils

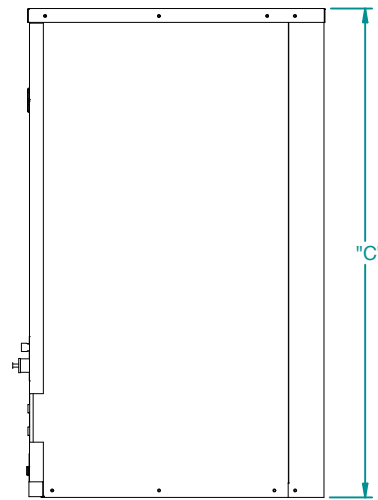
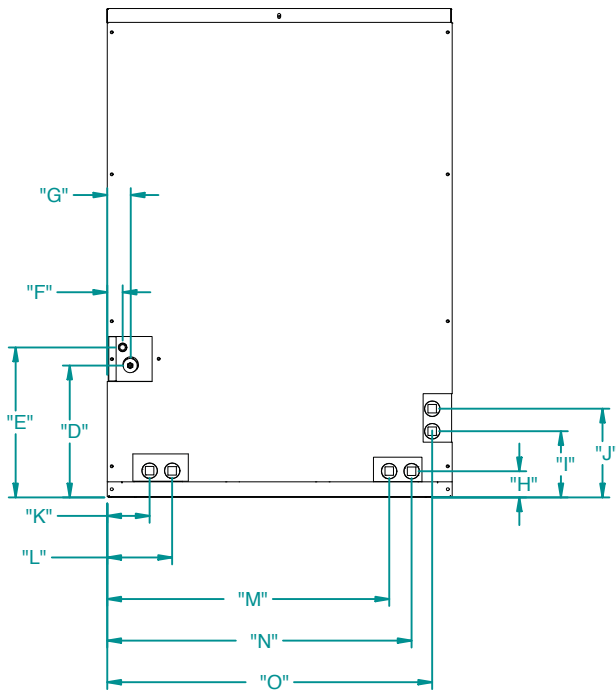
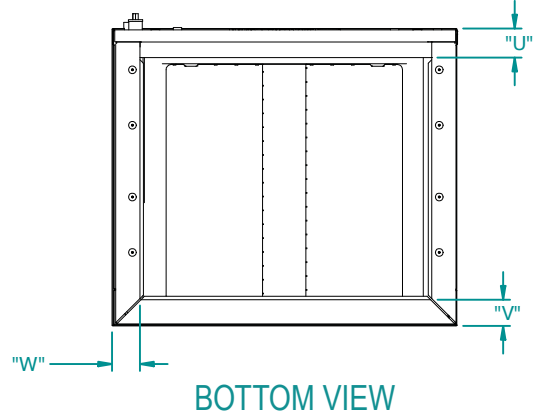
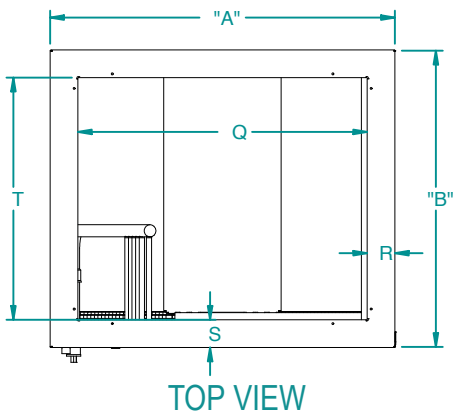

### SR CASED AIR COIL

Topflow & Horizontal Configuration	Overall Cabinet			Refrigerant Connections				Condensate Connections							Duct Connections								
	A	B	C	D	E	F	G	H	I	J	K	L	M	N	O	Q	R	S	T	U	V	W	
	Width	Depth	Height	Suction	Liquid	Suction	Liquid																
026	in.	17.8	21.5	26.3	8.8	10.1	1.0	1.6	1.9	4.8	6.4	2.7	4.4	13.0	14.6	16.2	13.9	2.0	2.0	17.6	2.0	2.0	2.0
	cm.	45.2	54.6	66.8	22.4	25.7	2.5	4.1	4.8	12.2	16.3	6.9	11.2	33.0	37.1	41.1	35.3	5.1	5.1	44.7	5.1	5.1	5.1
036	in.	21.5	21.5	31.1	8.5	9.8	1.1	1.7	1.7	4.6	6.3	3.0	4.6	16.8	18.4	20.2	17.6	2.0	2.0	17.6	2.0	2.0	2.0
	cm.	54.6	54.6	79.0	21.6	24.8	2.8	4.3	4.3	11.7	16.0	7.6	11.7	42.5	46.7	51.3	44.8	5.1	5.1	44.7	5.1	5.1	5.1
048-060	in.	24.9	21.4	35.3	9.5	10.8	1.1	1.7	1.9	4.8	6.4	3.0	4.7	20.3	22.0	23.5	21.0	2.0	2.0	17.6	2.0	2.0	2.0
	cm.	63.2	54.4	89.6	24.1	27.4	2.8	4.3	4.8	12.1	16.3	7.6	11.9	51.6	55.9	59.7	53.3	5.1	5.1	44.7	5.1	5.1	5.1

NOTE: Cased coils are shipped with a 1" Flange Kit.

## Engineering Guide Specifications

### General

The air handler shall provide vertical upflow, downflow, or horizontal configurations in one package. Units shall be listed by a nationally recognized safety-testing laboratory or agency, such as Underwriter's Laboratory (UL) or Environmental Testing Laboratories (Intertek-ETL). The air handler units shall be designed and AHRI performance listed to operate with the geothermal split condensing units as provided by the manufacturer. Each unit shall be pallet mounted and shipped using dense cardboard corners/top and stretch wrap for easy shipping damage inspection.

### Casing and Cabinet

The cabinet shall be fabricated from heavy-gauge galvanized steel and polyester powder coat paint to withstand 1000 hours of salt spray testing. The interior shall be insulated with 1 in. thick, multi-density, cleanable aluminum foil coated glass fiber with edges sealed or tucked under flanges to prevent the introduction of glass fibers into the discharge air. One large blower compartment access panel shall be provided and shall be removable with supply and return ductwork in place. The internal components layout shall provide for major service with the unit in-place for restricted access installations. The blower assembly access shall be slide-out serviceable via a 'works-in-a-drawer' design. The cabinet shall be convertible to horizontal or downflow applications by reconfiguring the cabinet using only a nut driver. The unit shall be 'zero clearance' approved on any of its external surfaces.

### Refrigeration Circuit

All units shall provide a fin tube air-to-refrigerant heat exchanger of the "A" coil design. The finned tube coil shall be sized for low-face velocity and constructed of lanced aluminum fins bonded to aluminum tubes in a staggered pattern. The coil shall include a composite drain pan.

The thermal expansion valve shall be factory installed and provide proper superheat over the entire liquid temperature range with minimal "hunting." The valve shall operate in the cooling mode through the use of an internal check valve.

### Blower Motor and Assembly

The blower shall be an oversized direct drive centrifugal type with a dynamically balanced wheel. The housing and wheel shall be designed for quiet low outlet velocity operation and of galvanized or galvalume steel construction. Tight blower housing geometry shall not be permitted. The blower housing shall be removable from the unit without disconnecting the supply air ductwork for servicing of the blower motor through a 'works-in-a-drawer' design. The high efficiency blower motor shall be either a 5 speed ECM or a variable speed ECM type. The blower motor shall be isolated from the housing by rubber grommets. The motor shall be permanently lubricated ball bearings and have thermal overload protection.

### Electrical

A control section shall be located within the air handler compartment and shall contain either a 75VA or 100VA transformer, 24 volt activated. Transformers shall be protected by internal circuit breakers. Units shall be name-plated for use with time delay fuses or HACR circuit breakers. Unit controls shall be either communicating or 24 volt type. An Aurora AHB (control option C), a microprocessor-based controller interfaces with the ABC located in the compressor section to control unit operation, shall be optional. The AHB control shall provide operational sequencing, blower speed control, air coil freeze detection, condensate overflow sensing, auxiliary heat staging, field selectable options, and accessory output.

An integral circuit breaker shall be provided on all units employing 15 kW or 20 kW electric heat. The control shall maintain the blower operation 30 seconds after the compressor or electric heat inputs have terminated.

A terminal block with screw terminals will be provided for field control wiring. All units shall have knockouts for entrance of low and line voltage wiring. The blower motor and control box shall be harness plug wired for easy removal.

An optional Aurora Interface Diagnostic (AID) Tool shall communicate with the Aurora control allowing quick and easy access to setup, monitoring, and troubleshooting of any Aurora control. The device shall include the features of fault description and history, manual operation capability, sensor readings, timings, and other diagnostic tools.

### Piping

Refrigerant connections shall be made using sweat copper joints. The condensate connections shall be a 3/4 in. NPT.

## Revision Guide

---

<b>Pages:</b>	<b>Description:</b>	<b>Date:</b>	<b>By:</b>
10-14	Updated Wiring Schematics	20 Jan 2021	JM
10-14	Updated Wiring Schematics	02 May 2017	MA
All	Document Creation	01 May. 2017	JM



Product: **SAH Air Handler & Air Coil Series**  
Type: Geothermal Heat Pumps  
Size: 2-6 Ton

Document Type: Specification Catalog  
Part Number: SC2518AK6  
Release Date: 03/21

©2021 The manufacturer has a policy of continual product research and development and reserves the right to change design and specifications without notice.

York is a registered trademark of Johnson Controls, Inc., and is used with permission.