



Heating and Air Conditioning

SPECIFICATION CATALOG

**LX SERIES
GEOTHERMAL HEAT PUMPS
DUAL CAPACITY**

**MODELS:
YLF 026 - 072
(2 THRU 6 NOMINAL TONS)**



Due to continuous product improvement, specifications are subject to change without notice.

Visit us on the web at www.york-geothermal.com

Additional rating information can be found at www.ahridirectory.org

FOR DISTRIBUTION USE ONLY - NOT TO BE USED AT POINT OF RETAIL SALE

Table of Contents

Model Nomenclature	5
AHRI/ISO 13256-1 Performance Ratings.....	6-7
LX Series Design Features	8-10
The Aurora™ Control System	11-16
Operation Logic Data Table	16
Water Quality	17
Dimensional Data	18-19
Physical Data	20
Auxiliary Heat Ratings	21
Auxiliary Heat Electrical Data	21
Electrical Data	21
Blower Performance Data	22-23
Reference Calculations	24
Legend and Notes	24
Operating Limits	24
Antifreeze Corrections	25
Correction Factor Tables	26
Pressure Drop	27
Performance Data	28-37
Wiring Schematics	38-41
Engineering Guide Specifications	42-44
Revision Guide	45

L X S E R I E S

Single & Dual Capacity Geothermal Heat Pump



The LX Series is our newest offering and was designed to complement our Affinity Series. The LX Series offers two-stage scroll compressors and 5-Speed ECM blowers for high efficiency and quiet operation. It's our first residential unit to come standard with durable all-aluminum air coils for formicary corrosion protection and our proprietary AlumiSeal™ coating option for extra peace of mind. All models utilize ozone-safe R410A refrigerant to meet the most stringent EPA requirements. The LX Series is available in five dual capacity sizes (2 to 6 ton) with Copeland Scroll UltraTech™ compressors.

5-Speed ECM blower motors bridge the gap of high efficiency ECM capability with great value. ECM blowers are used to increase comfort, efficiency, and airflow flexibility. The Aurora 'Base' Controls (ABC) features a microprocessor control system to sequence all components during operation for optimum performance. Plus, the ABC provides easy-to-use troubleshooting features with fault lights, on-board diagnostics, and a hand held Aurora Interface and Diagnostics (AID) Tool. Unit configurations include vertical top discharge (left and right return) and horizontal units with left or right return and side or end discharge. Heavy-gauge metal cabinets are fully insulated and coated with an attractive and durable powder coat paint for long lasting protection.

LX Series products are performance-certified to AHRI/ISO 13256-1 standards, ETL listed, ENERGY STAR® qualified, and tested in an ISO 17025 accredited testing lab.

As a leader in the industry, we are dedicated to innovation, quality, and customer satisfaction. In fact, every unit built is exposed to a wide range of quality control procedures throughout the assembly process in our ISO 9001:2008 certified manufacturing facility. At the end, it is subjected to a rigorous battery of computerized run tests to certify that it meets or exceeds performance standards for efficiency and safety, and will perform flawlessly at startup. As further affirmation of our quality standards, each unit carries our exclusive Quality Assurance emblem, signed by the final test technician.

Model Nomenclature

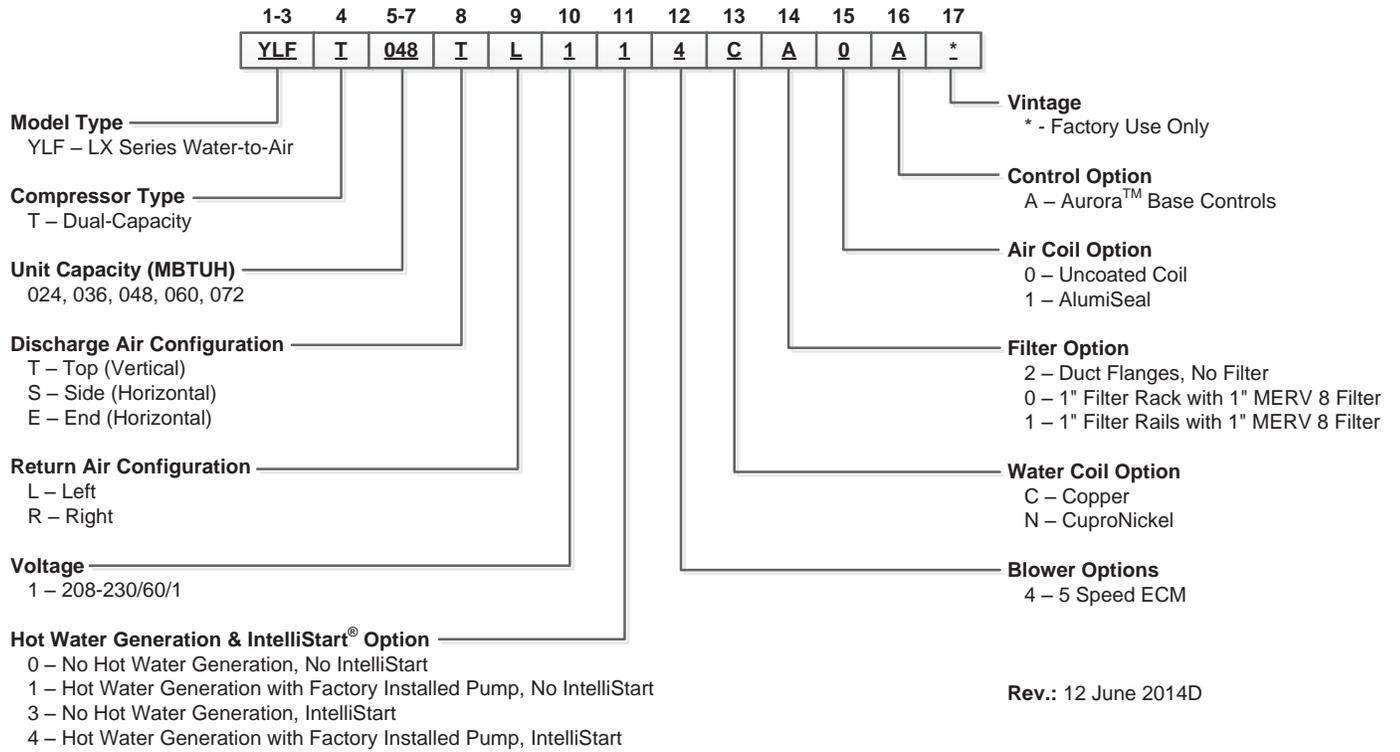

Rev.: 12 June 2014D

AHRI/ISO 13256-1 Performance Ratings

5 Speed ECM motor AHRI/ASHRAE/ISO 13256-1

English (IP) Units

Model	Capacity Modulation	Flow Rate		Water Loop Heat Pump				Ground Water Heat Pump				Ground Loop Heat Pump			
				Cooling EWT 86°F		Heating EWT 68°F		Cooling EWT 59°F		Heating EWT 50°F		Cooling Brine Full Load 77°F Part Load 68°F		Heating Brine Full Load 32°F Part Load 41°F	
		gpm	cfm	Capacity Btuh	EER Btuh/W	Capacity Btuh	COP	Capacity Btuh	EER Btuh/W	Capacity Btuh	COP	Capacity Btuh	EER Btuh/W	Capacity Btuh	COP
024	Full	8	800	22,000	13.9	28,300	4.9	25,100	20.6	23,500	4.4	23,100	15.6	18,900	3.8
	Part	7	600	16,300	14.7	20,800	5.3	18,800	24.4	17,000	4.5	18,200	20.6	14,900	4.1
036	Full	9	1200	33,700	13.5	42,500	4.7	38,000	19.7	35,500	4.2	35,100	15.5	26,000	3.6
	Part	8	1000	25,300	15.4	30,500	5.3	28,900	25.5	25,200	4.5	27,600	21.5	21,000	4.1
048	Full	12	1600	46,500	14.8	53,900	4.8	52,300	21.8	45,000	4.3	49,000	16.1	36,000	3.7
	Part	11	1400	34,800	16.5	39,700	5.4	39,800	27.3	32,800	4.5	38,200	22.1	28,500	4.1
060	Full	16	1800	57,200	14.3	69,000	4.5	64,100	20.7	56,500	4.0	59,900	16.5	45,300	3.4
	Part	14	1500	43,000	15.9	51,000	4.9	49,100	26.2	42,400	4.2	47,200	22.3	36,000	3.9
072	Full	18	1900	64,400	14.4	82,800	4.5	71,800	20.8	68,500	4.1	67,000	16.4	52,000	3.5
	Part	16	1550	50,400	15.7	63,600	4.8	56,800	25.3	52,800	4.1	54,200	21.9	42,500	3.7

Cooling capacities based upon 80.6°F DB, 66.2°F WB entering air temperature
 Heating capacities based upon 68°F DB, 59°F WB entering air temperature
 All ratings based upon 208V operation

3/24/17

5 Speed ECM motor ARI/ASHRAE/ISO 13256-1

Metric (SI) Units

Model	Capacity Modulation	Flow Rate		Water Loop Heat Pump				Ground Water Heat Pump				Ground Loop Heat Pump			
				Cooling EWT 30°C		Heating EWT 20°C		Cooling EWT 15°C		Heating EWT 10°C		Cooling Brine Full Load 25°C Part Load 20°C		Heating Brine Full Load 0°C Part Load 5°C	
		water L/S	air L/S	Capacity Watts	EER (W/W)	Capacity Watts	COP	Capacity Watts	EER (W/W)	Capacity Watts	COP	Capacity Watts	EER (W/W)	Capacity Watts	COP
024	Full	0.5	377.6	6,448	4.1	8,294	4.9	7,356	6.0	6,887	4.4	6,770	4.6	5,539	3.8
	Part	0.4	283.2	4,777	4.3	6,096	5.3	5,510	7.2	4,982	4.5	5,334	6.0	4,367	4.1
036	Full	0.6	566.4	9,877	4.0	12,456	4.7	11,137	5.8	10,404	4.2	10,287	4.5	7,620	3.6
	Part	0.5	472.0	7,415	4.5	8,939	5.3	8,470	7.5	7,386	4.5	8,089	6.3	6,155	4.1
048	Full	0.8	755.2	13,628	4.3	15,797	4.8	15,328	6.4	13,189	4.3	14,361	4.7	10,551	3.7
	Part	0.7	660.8	10,199	4.8	11,635	5.4	11,665	8.0	9,613	4.5	11,196	6.5	8,353	4.1
060	Full	1.0	849.6	16,764	4.2	20,223	4.5	18,787	6.1	16,559	4.0	17,556	4.8	13,277	3.4
	Part	0.9	708.0	12,603	4.7	14,947	4.9	14,390	7.7	12,427	4.2	13,834	6.5	10,551	3.9
072	Full	1.1	896.8	18,875	4.2	24,267	4.5	21,043	6.1	20,076	4.1	19,637	4.8	15,240	3.5
	Part	1.0	731.6	14,771	4.6	18,640	4.8	16,647	7.4	15,475	4.1	15,885	6.4	12,456	3.7

Cooling capacities based upon 27°C DB, 19°C WB entering air temperature
 Heating capacities based upon 20°C DB, 15°C WB entering air temperature
 All ratings based upon 208V operation

3/24/17

cfm*0.472 = l/s
 gpm*0.0631 = l/s
 in wg*249 = pascals
 ft of hd *2990 = pascals

Energy Star Compliance Table

Model	Tier 3	
	Ground Water	Ground Loop
024	Yes	Yes
036	Yes	Yes
048	Yes	Yes
060	Yes	Yes
072	Yes	Yes

12/14/2016

Energy Star Rating Criteria

In order for water-source heat pumps to be Energy Star rated they must meet or exceed the minimum efficiency requirements listed below. Tier 3 represents the current minimum efficiency water source heat pumps must have in order to be Energy Star rated.

Tier 3: 1/1/2012 – No Effective End Date Published

Water-to-Air	EER	COP
Ground Loop	17.1	3.6
Ground Water	21.1	4.1
Water-to-Water		
Ground Loop	16.1	3.1
Ground Water	20.1	3.5

AHRI/ISO 13256-1 Performance Ratings cont.

The performance standard AHRI/ASHRAE/ISO 13256-1 became effective January 1, 2000 and replaces ARI Standards 320, 325, and 330. This new standard has three major categories: Water Loop (comparable to ARI 320), Ground Water (ARI 325), and Ground Loop (ARI 330). Although these standards are similar there are some differences:

Unit of Measure: The Cooling COP

The cooling efficiency is measured in EER (US version measured in Btu/h per Watt. The Metric version is measured in a cooling COP (Watt per Watt) similar to the traditional COP measurement.

Water Conditions Differences

Entering water temperatures have changed to reflect the centigrade temperature scale. For instance the water loop heating test is performed with 68°F (20°C) water rounded down from the old 70°F (21.1°C).

Air Conditions Differences

Entering air temperatures have also changed (rounded down) to reflect the centigrade temperature scale. For instance the cooling tests are performed with 80.6°F (27°C) dry bulb and 66.2°F (19°C) wet bulb entering air instead of the traditional 80°F (26.7°C) DB and 67°F (19.4°C) WB entering air temperatures. 80.6/66.2 data may be converted to 80/67 using the entering air correction table. This represents a significantly lower relative humidity than the old 80/67 of 50% and will result in lower latent capacities.

Pump Power Correction Calculation

Within each model, only one water flow rate is specified for all three groups and pumping Watts are calculated using the following formula. This additional power is added onto the existing power consumption.

- Pump power correction = (gpm x 0.0631) x (Press Drop x 2990) / 300

Where 'gpm' is waterflow in gpm and 'Press Drop' is the pressure drop through the unit heat exchanger at rated water flow in feet of head.

Blower Power Correction Calculation

Blower power is corrected to zero external static pressure using the following equation. The nominal airflow is rated at a specific external static pressure. This effectively reduces the power consumption of the unit and increases cooling capacity but decreases heating capacity. These Watts are significant enough in most cases to increase EER and COPs fairly dramatically over ARI 320, 325, and 330 ratings.

- Blower Power Correction = (cfm x 0.472) x (esp x 249) / 300

Where 'cfm' is airflow in cfm and 'esp' is the external static pressure at rated airflow in inches of water gauge.

ISO Capacity and Efficiency Calculations

The following equations illustrate cooling calculations:

- ISO Cooling Capacity = Cooling Capacity (Btu/h) + (Blower Power Correction (Watts) x 3.412)
- ISO EER Efficiency (W/W) = ISO Cooling Capacity (Btu/h) x 3.412 / [Power Input (Watts) - Blower Power Correction (Watts) + Pump Power Correction (Watt)]

The following equations illustrate heating calculations:

- ISO Heating Capacity = Heating Capacity (Btu/h) - (Blower Power Correction (Watts) x 3.412)
- ISO COP Efficiency (W/W) = ISO Heating Capacity (Btu/h) x 3.412 / [Power Input (Watts) - Blower Power Correction (Watts) + Pump Power Correction (Watt)]

Comparison of Test Conditions

	ARI 320	ISO/AHRI 13256-1 WLHP	ARI 325	ISO/AHRI 13256-1 GWHP	ARI 330	ISO/AHRI 13256-1 GLHP
Cooling						
Entering Air - DB/WB °F	80/67	80.6/66.2	80/67	80.6/66.2	80/67	80.6/66.2
Entering Water - °F	85	86	50/70	59	77	77
Fluid Flow Rate	*	**	**	**	**	**
Heating						
Entering Air - DB/WB °F	70	68	70	68	70	68
Entering Water - °F	70	68	50/70	50	32	32
Fluid Flow Rate	*	**	**	**	**	**

NOTES: * Flow rate is set by 10°F rise in standard cooling test

** Flow rate is specified by the manufacturer

Part load entering water conditions not shown

WLHP = Water Loop Heat Pump; GWHP = Ground Water Heat Pump; GLHP = Ground Loop Heat Pump

Conversions:

Airflow (lps) = cfm x 0.472;

WaterFlow (lps) = gpm x 0.0631;

ESP (Pascals) = ESP (in wg) x 249;

Press Drop (Pascals) = Press Drop (ft hd) x 2990

LX SERIES Design Features



- ① **COMPRESSOR:** Copeland Scroll UltraTech™ (dual capacity) represent the latest technology (not shown)
- ② **DOUBLE ISOLATED COMPRESSOR:** Double isolated compressor mounting to reduce noise and vibration (not shown)
- ③ **AURORA CONTROLS & AID TOOL:** Aurora 'Base' Control and Aurora AID Tool
- ④ **OPTIONAL HOT WATER ASSIST:** Provides free hot water in cooling and very high efficiency hot water generation in heating mode. Internally mounted pump.
- ⑤ **COAXIAL HEAT EXCHANGER:** Standard large high efficiency copper (optional cupronickel) coax with our exclusive void-free and robotically applied ThermaShield insulation coating
- ⑥ **BALANCED PORT/BIDIRECTIONAL EXPANSION VALVE:** Balanced port bidirectional expansion valve for rock steady superheat control and reliable efficiency and operation at any condition
- ⑦ **AIR COIL:** All aluminum air coil to prevent formicary corrosion.
- ⑧ **DISCHARGE MUFFLER:** Helps quiet compressor gas pulsations
- ⑨ **5-SPEED ECM BLOWER MOTOR:** Standard high efficiency 5-Speed ECM motor.
- ⑩ **RETURN AIR CONNECTION:** Standard with return air duct flanges and no filter. Optional 1" filter rails or 1" filter rack with 1" MERV8 filter.
- ⑪ **FILTER:** High holding capacity 1 in. pleated MERV 8 filter is optional (not shown)
- ⑫ **SWIVEL LOOP CONNECTIONS:** Leak free swivel water connections provide a hand tight gasket connection that easily handles the temperature extremes of geothermal earth loops
- ⑬ **INTELLISTART®:** Optional single phase soft starter
- ⑭ **INSULATION:** Cleanable foil lined insulation to prevent mold growth; corrosion resistant composite drain pan
- ⑮ **CABINET FINISH:** Heavy gauge galvanized sheet metal cabinet has 1,000 hr. salt spray rated gray powder coat paint for long life
- ⑯ **ACCESS PANELS:** Lift out front bottom access panel, lift out panels for easier removal and servicing
- ⑰ **CONTROL BOX:** Unit controls feature quick connect wiring harnesses for easy servicing. Separate knockouts for LV and two for power on two sides allow easy access to the control box. 75VA transformer assures adequate controls power.
- ⑱ **HOT WATER GENERATOR SWITCH & AID TOOL PORT:** Hot water generator switch for easy enabling/disabling of the hot water generator pump; AID Tool port provides quick AID Tool connection

LX SERIES Design Features cont.

What's New?

- AHRI/ISO 13256-1 Ratings meet ENERGY STAR® requirements
- ENERGY STAR® Most Efficient recognized - 2 Way communicating controls and efficiency that meets or exceeds minimum requirement.
- All aluminum air coils prevent formicary corrosion
- Latest technology compressors
 - Copeland UltraTech™ K5 Compressors in dual capacity units (sizes 024, 036, 048, 060, 072)
- Discharge line mufflers on all models to help quiet compressor discharge gas pulsations.
- 5-Speed ECM blower motor for high efficiency
- Communicating Digital Thermostats: The Aurora controls system features either monochromatic or color touch screen graphic display thermostats for user interface. These displays not only feature easy to use graphical interface but display alerts and faults in plain English.
- Aurora™ Communicating Control Features
 - Traditional Safety Sensors: HP, LP, condensate overflow, freeze detection loop, freeze detection air coil
 - Electric Heat Powered Blower and Controls: Prevents the compressor from tripping out and disabling heat in the house
- Advanced Service Features
 - Aurora Controls with the AID Tool provide advanced service diagnostics. With this device setup and configurations as well as real-time sensors fault and lockout history can be monitored and much more.
 - Cabinet Design – Improved design of access panels for ease of access
- Cabinet Configurations – Vertical left or right return, horizontal left or right return with either end or side air discharge

Application Flexibility

- Safe, efficient operation in a wide range of liquid temperatures (20°F to 120°F) and flow rates (as low as 1.5 gpm/ton in open loop applications when EWT >50°F)
- Top air discharge for upflow in vertical units, side or end discharge for horizontal units
- True left or right return air locations—vertical units include duct collar/return air flanges
- 5-Speed ECM blower motors provide ECM efficiency at PSC capability
- Narrow cabinet for easy movement through doorways
- Internally trapped condensate piping on vertical units for neat, compact installation
- Optional field-installed auxiliary electric heater
- Corner-located electrical box for field wiring from two sides
- Circuit breaker protected loop pump power block for easy wiring
- Relay to control field-mounted accessories
- Field-selectable freeze detection setting for well or closed loop systems

- Simple to install and simple to service - Unlike some geothermal heat pumps, cabinet allows plenty of access and has spacious interior. The Aurora AID Tool makes set up and diagnostics a breeze.

Operating Efficiencies

- AHRI/ISO 13256-1 rating for heating COPs, cooling EERs, and low water flow requirements
- Optional hot water generator with internal pump generates hot water at considerable savings while improving overall system efficiency
- High-stability expansion valve delivers optimum refrigerant flow over a wide range of conditions and provides bidirectional operation without troublesome check valves
- Efficient scroll compressors operate quietly
- Coaxial tube water-to-refrigerant heat exchanger operates at low liquid pressure drops
- Convoluted copper water tube functions efficiently at low flow rates
- Large, low-RPM blowers with 5-Speed ECM motors provide quiet and efficient air movement with high static capability.
- Utilizes the ozone-friendly R-410A refrigerant which produces higher efficiencies and warmer discharge air temperatures

Service Advantages

- Removable panels: three for the compressor compartment and one (on horizontals) or two (on verticals) for the air handling compartment to provide quick access to all internal components with ductwork in place
- Easily accessible thermal expansion valve
- Brass, swivel-type water connections for quick connection union, and elimination of wrenches and sealants during installation; sweat type connections are on the hot water generator
- Insulated divider and separate air handling/compressor access panels permit service testing without air bypass
- Designed for front access in tight applications
- LED fault and status lights on the Aurora board with memory for easy diagnostics

LX SERIES Design Features cont.

- Aurora AID Tool provides enhanced service information via communication directly with the Aurora control including sensor inputs, fault history, and much more
- Detachable thermostat connection strip for wiring convenience
- Hot water pump shut-off switch for easy startup and service
- Control box and blower motors have quick-attach wiring plugs for easy removal
- Internal drop-out blower with permanently-lubricated ball bearing motor
- High- and low-pressure service ports in refrigerant circuit.
- Blower and transformer powered from auxiliary heat supply (when installed) to provide emergency heat with open compressor circuit breaker

Product Quality

- Heavy-gauge steel cabinets are painted with durable powder coat paint for long lasting beauty and service
- Coaxial heat exchanger, refrigerant suction lines, hot water generator coil, and all water pipes are fully insulated to reduce condensation problems in low temperature operation
- All aluminum air coils prevent formicary corrosion.
- Noise reduction features include double isolation mounted compressors and soft starting blower motors; insulated compressor compartment; interior cabinet insulation using 1/2 in. coated glass fiber; discharge muffler
- Safety features include high- and low-pressure refrigerant controls to protect the compressor, condensate overflow protection, freeze detection sensor to safeguard the coaxial heat exchanger, hot water high-limit, and fault lockout enables emergency heat and prevents compressor operation until thermostat or circuit breaker is reset

Microprocessor Benefits

- Communicating monochromatic or color digital auto-changeover thermostat with 3-stage heating/2-stage cooling holds precise temperature and provides varying blower speed control
- Component sequencing delays for quiet startup, shutdown, and timed staging of auxiliary electric heat
- Communication capability for future expansions

Options and Accessories

- Communicating Digital Thermostats
 - Monochromatic Graphic Display Thermostats: For user interface with the Aurora system; these displays not only feature easy to use graphical interface but display alerts and faults in plain English.

- Color Touch Screen Graphic Display Thermostats: For user interface with the Aurora system; these displays not only feature easy to use graphical interface but display alerts and faults in plain English. Other features include full color implementation, user loaded background photos, and USB port for easy configuration and software updates.

- IntelliZone2 24V Zone System: The IntelliZone2 24V zoning system provides 4 zones (Dual Capacity), or 2 zones (Single Speed) of individualized comfort via communication to the Aurora Control System.
- AID Tool: The Aurora Interface and Diagnostics (AID) Tool is a plug-in configuration and troubleshooting tool for the Aurora Control System.
- Optional cupronickel heat exchangers for open loop applications
- Optional hot water generator with internally mounted pump and water heater plumbing connector
- Electronic auto-changeover thermostat with 3-stage heating/2-stage cooling and indicator LEDs (non-communicating)
- Optional 1" MERV 8 Filter
- 24 Volt 1 in. electronic air cleaner
- 90% efficient, cleanable electrostatic filters
- Closed loop flow center in several sizes
- Auxiliary electric heater
- Hose kits
- Additional accessory relay
- IntelliStart soft starter

Manufacturing Quality

- All units are computer run-tested, with conditioned source water, in all modes to ensure efficiency and reliability
- All refrigerant brazing is performed in a nitrogen atmosphere
- All units are deep evacuated to less than 150 microns prior to refrigerant charging
- All joints are helium leak-tested to ensure an annual leak rate of less than 1/4 ounce
- All major components bar coded; eliminating possibility of mismatched parts built into unit
- All assembly technicians thoroughly trained in proper quality procedures
- All units have model number and serial number embedded in control for local or remote retrieval
- Manufacturing facility is ISO 9001:2008 certified
- Engineering labs are ISO 17025 accredited

The Aurora™ Control System

Aurora ‘Base’ Control

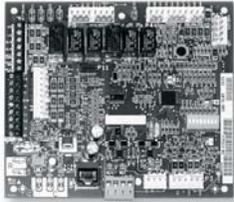

The Aurora ‘Base’ Control (ABC) System is a complete residential and commercial comfort system that brings all aspects of the HVAC system into one cohesive module network. The ABC features microprocessor control and HP, LP, condensate and freeze detection, over/under voltage faults, along with

communicating thermostat capability for complete fault detection text at the thermostat. Aurora uses the Modbus communication protocol to communicate between modules. Each module contains the logic to control all features that are connected to the module. The Aurora ‘Base’ Control (ABC) has two Modbus channels. The first channel is configured as a master for connecting to devices such as a communicating thermostat or other slave devices. The second channel is configured as a slave for connecting the Aurora Interface Diagnostics Tool (AID Tool).

Aurora Control Features	Description	Aurora ‘Base’
Microprocessor Compressor Control	Microprocessor control of compressor for timings with FP1, HP, LP, Condensate, assignable Acc relay	•
Base Hot Water Generator Operation	Compressor Contactor powers Hot Water Generator Pump with inline circuit breaker and thermostat limit.	•
Base Loop Pump Control	Compressor Contactor powers Loop Pump with inline circuit breaker and no loop pump linking capability.	•
Load Shed/Utility Input	Allows simple input to externally enable of occupied/unoccupied mode for basic utility time of use programs.	•

Service Device	Description	Aurora ‘Base’
 Aurora Interface and Diagnostics (AID) Tool	Allows setup, monitoring and troubleshooting of any Aurora Control. NOTE: Although the ABC has basic compatibility with all Aurora, new product features may not be available on older AID Tools.	For Service (Ver. 2.xx or greater)

Add On Thermostats and Zoning	Description	Aurora ‘Base’
 TP32U03/04 - MonoChrome Traditional Y1, Y2 Thermostat	Elite Stat with full English fault codes and alerts, traditional Y1, Y2 thermostat, 8 wire installation	Optional
 TP32S01/02 - Traditional Y1, Y2 Thermostat	Traditional Y1, Y2 thermostat, 8 wire installation	Optional
 TPCM32U03A*/04A* - MonoChrome Communicating Thermostat	Elite Stat with full English fault codes and alerts, communicating thermostat, 4 wire installation	Optional
 TPCC32U01 - Color Touchscreen Communicating Thermostat	4.3 in. color touchscreen communicating thermostat with full English fault codes and alerts, 4 wire installation	Optional
 IntelliZone2® • 24V Zoning	IntelliZone2® • 24V is a communicating zoning system that includes color main thermostat and up to 4 zones (with dual capacity). There are 3 thermostat options (MasterStat, SensorStat, ZoneStat). Includes daughter board to translate communication to 24VAC for heat pump	Optional

The Aurora 'Base' Control System cont.

Aurora 'Base' Control

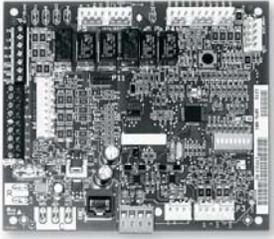

NOTE: Refer to the Aurora Base Control Application and Troubleshooting Guide and the Instruction Guide: Aurora Interface and Diagnostics (AID) Tool for additional information.

Control Features

Software ABC Standard Version 3.0

5-Speed ECM Blower Motor

A 5-Speed ECM blower motor will be driven directly using the thermostat connections. Any of the G, Y1, or Y2/W signals can drive any of the 5 available pre-programmed blower speeds on the motor.

Other Control Features

- Random start at power up
- Anti-short cycle protection
- High and low pressure cutouts
- Loss of charge
- Water coil freeze detection
- Over/under voltage protection
- Condensate overflow sensor
- Load shed
- Emergency shutdown
- Diagnostic LED
- Test mode push button switch
- Two auxiliary electric heat outputs
- Alarm output
- Accessory output with N.O. and N.C.
- Modbus communication (master)
- Modbus communication (slave)

Field Selectable Options via Hardware

DIP Switch (SW1) – Test/Configuration Button (See SW1 Operation Table)

Test Mode

The control is placed in the test mode by holding the push button switch SW1 for 2 - 5 seconds. In test mode most of the control timings will be shortened by a factor of sixteen (16). LED3 (green) will flash at 1 second on and 1 second off. Additionally, when entering test mode LED1 (red) will flash the last lockout one time. Test mode will automatically time out after 30 minutes.

Test mode can be exited by pressing and holding the SW1 button for 2 to 5 seconds or by cycling the power. **NOTE:** Test mode will automatically be exited after 30 minutes.

Reset Configuration Mode

The control is placed in reset configuration mode by holding the push button switch SW1 for 50 to 60 seconds. This will reset all configuration settings and the EEPROM back to the factory default settings. LED3 (green) will turn off when entering reset configuration mode. Once LED3 (green) turns off, release SW1 and the control will reset.

DIP Switch (SW2)

SW2-1 FP1 Selection – Low water coil temperature limit setting for freeze detection. On = 30°F; Off = 15°F.

SW2-2 Not Used

SW2-3 RV – O/B - thermostat type. Heat pump thermostats with "O" output in cooling or "B" output in Heating can be selected. On = O; Off = B.

SW2-4 and 2-5 Access Relay Operation (P2)

Access Relay Operation	SW2-4	SW2-5
Cycle with Blower	ON	ON
Cycle with Compressor	OFF	OFF
Water Valve Slow Opening	ON	OFF
Cycle with Comm. T-stat Hum Cmd	OFF	ON

Cycle with Blower - The accessory relay will cycle with the blower output.

Cycle with Compressor - The accessory relay will cycle with the compressor output.

Water Valve Slow Opening - The accessory relay will cycle and delay both the blower and compressor output for 90 seconds.

SW2-6 CC Operation – selection of single or dual capacity compressor. On = Single Stage; Off = Dual Capacity

SW2-7 Lockout and Alarm Outputs (P2) – selection of a continuous or pulsed output for both the LO and ALM Outputs. On = Continuous; Off = Pulsed

SW2-8 Future Use

Alarm Jumper Clip Selection

From the factory, ALM is connected to 24 VAC via JW2. By cutting JW2, ALM becomes a dry contact connected to ALG.

The Aurora 'Base' Control System cont.

Field Selectable Options via Software

(Selectable via the Aurora AID Tool)

Safety Features

The following safety features are provided to protect the compressor, heat exchangers, wiring and other components from damage caused by operation outside of design conditions.

Fuse – a 3 amp automotive type plug-in fuse provides protection against short circuit or overload conditions.

Anti-Short Cycle Protection – 4 minute anti-short cycle protection for the compressor.

Random Start – 5 to 80 second random start upon power up.

Fault Retry – in the fault condition, the control will stage off the outputs and then “try again” to satisfy the thermostat Y input call. Once the thermostat input calls are satisfied, the control will continue on as if no fault occurred. If 3 consecutive faults occur without satisfying the thermostat Y input call, then the control will go to Lockout mode.

Lockout – when locked out, the blower will operate continuously. The Alarm output (ALM) and Lockout output (L) will be turned on. The fault type identification display LED1 (Red) shall flash the fault code. To reset lockout conditions with SW2-8 On, thermostat inputs “Y1”, “Y2”, and “W” must be removed for at least 3 seconds. To reset lockout conditions with SW2-8 Off, thermostat inputs “Y1”, “Y2”, “W”, and “DH” must be removed for at least 3 seconds. Lockout may also be reset by turning power off for at least 30 seconds or by enabling the emergency shutdown input for at least 3 seconds.

Lockout With Emergency Heat - if the control is locked out in the heating mode and W input is received, the control will operate in the emergency heat mode while the compressor is locked out. The first emergency heat output will be energized 10 seconds after the W input is received, and the blower will shift to high speed. If the control remains locked out, and the W input is present, additional stage of emergency heat will stage on after 2 minutes. When the W input is removed, all of the emergency heat outputs and blower will turn off.

High Pressure – fault is recognized when the Normally Closed High Pressure Switch, P4-9/10 opens, no matter how momentarily. The High Pressure Switch is electrically in series with the Compressor Contactor and serves as a hard-wired limit switch if an overpressure condition should occur.

Low Pressure - fault is recognized when the Normally Closed Low Pressure Switch, P4-7/8 is continuously open for 30 seconds. Closure of the LPS any time during the 30 second recognition time restarts the 30 second continuous open requirement. A continuously open LPS shall not be recognized during the 2 minute startup bypass time.

Loss of Charge – fault is recognized when the Normally Closed Low Pressure Switch, P4-7/8 is open prior to the compressor starting.

Condensate Overflow - fault is recognized when the impedance between this line and 24 VAC common or chassis ground drops below 100K ohms for 30 seconds continuously.

Freeze Detection (Coax) - set points shall be either 30°F or 15°F. When the thermistor temperature drops below the selected set point, the control shall begin counting down the 30 seconds delay. If the thermistor value rises above the selected set point, then the count should reset. The resistance value must remain below the selected set point for the entire length of the appropriate delay to be recognized as a fault. This fault will be ignored for the initial 2 minutes of the compressor run time.

Over/Under Voltage Shutdown - An over/under voltage condition exists when the control voltage is outside the range of 18 VAC to 30 VAC. If the over/under voltage shutdown lasts for 15 minutes, the lockout and alarm relay will be energized. Over/under voltage shutdown is self-resetting in that if the voltage comes back within range of 18 VAC to 30 VAC for at least 0.5 seconds, then normal operation is restored.

Operation Description

Power Up - The unit will not operate until all the inputs and safety controls are checked for normal conditions. The unit has a 5 to 80 second random start delay at power up. Then the compressor has a 4 minute anti-short cycle delay after the random start delay.

Standby - In standby mode, Y1, Y2, W, DH, and G are not active. Input O may be active. The blower and compressor will be off.

Heating Operation

Heating, 1st Stage (Y1) - The blower is started on “Y1” speed immediately and the compressor is energized 10 seconds after the Y1 input is received.

Heating, 2nd Stage (Y1, Y2) - The compressor will be staged to full capacity 20 seconds after Y2 input is received. The 5 speed ECM blower will shift to Y2 speed immediately.

Heating, 3rd Stage (Y1, Y2, W) - The first stage of electric heat is energized 10 seconds after the W command is received. Blower will increase to "W" speed immediately. If the demand continues the second stage of electric heat will be energized after 5 minutes.

The Aurora 'Base' Control System cont.

Emergency Heat (W) - The blower will be started on "W" speed, 10 seconds later the first stage of electric heat will be turned on. If the emergency heat demand is not satisfied after 2 minutes the second electric heat stage will be energized.

Blower (G) - The blower will start immediately upon receiving a thermostat G command. If there are no other commands from the thermostat the ECM will run on "G" speed until the G command is removed. Regardless of blower input (G) from the thermostat, the blower will remain on for 30 seconds at the end of each heating cycle.

Cooling Operation

In all cooling operations, the reversing valve directly tracks the O input. Thus, anytime the O input is present, the reversing valve will be energized.

Cooling, 1st Stage (Y1, O) - The blower is started on "Y1" speed immediately and the compressor is energized 10 seconds after the Y1 input is received.

Cooling, 2nd Stage (Y1, Y2, O) - The compressor will be staged to full capacity 20 seconds after Y2 input is received. The 5 speed ECM blower will shift to Y2 speed immediately.

Emergency Shutdown - Four (4) seconds after a valid ES input, P2-7 is present, all control outputs will be turned off and remain off until the emergency shutdown input is no longer present. The first time that the compressor is started after the control exits the emergency shutdown mode, there will be an anti-short cycle delay followed by a random start delay. Input must be tied to common to activate.

Continuous Blower Operation - The blower output will be energized any time the control has a G input present, unless the control has an emergency shutdown input present. The blower output will be turned off when G input is removed.

Load Shed - The LS input disables all outputs with the exception of the blower output. When the LS input has been cleared, the anti-short cycle timer and random start timer will be initiated. Input must be tied to common to activate.

Aurora 'Base' Control LED Displays

These three LEDs display the status, configuration, and fault codes for the control. These can also be read in plain English via the Aurora AID Tool.

Status LED (LED3, Green)

Description of Operation	Fault LED, Green
Normal Mode	ON
Control is Non-functional	OFF
Test Mode	Slow Flash
Lockout Active	Fast Flash
Dehumidification Mode	Flash Code 2
(Future Use)	Flash Code 3
(Future Use)	Flash Code 4
Load Shed	Flash Code 5
Emergency Shutdown	Flash Code 6
Smart Grid	Flash Code 7

Configuration LED (LED2, Yellow)

Description of Operation	Configuration LED, Yellow
No Software Overwritten	Flashing ECM Setting
DIP Switch was Overwritten	Slow Flash
ECM Configuration Mode	Fast Flash

Fault LED (LED1, Red)

	Red Fault LED	LED Flash Code*	Lockout	Reset/Remove
ABC Basic Faults	Normal - No Faults	OFF	-	
	Fault - Input	1	No	Auto
	Fault - High Pressure	2	Yes	Hard or Soft
	Fault - Low Pressure	3	Yes	Hard or Soft
	Fault - Freeze Detection FP2	4	Yes	Hard or Soft
	Fault - Freeze Detection FP1	5	Yes	Hard or Soft
	Fault - Condensate Overflow	7	Yes	Hard or Soft
	Fault - Over/Under Voltage	8	No	Auto
	Fault - FP1 Sensor Error	11	Yes	Hard or Soft
	Fault - CritComErr	19	NO	Auto

NOTE: All codes >11 use long flash for tens digit and short flash for the ones digit. 20, 30, 40, 50, etc. are skipped.

The Aurora 'Base' Control System cont.

Aurora Interface and Diagnostics (AID) Tool



The Aurora Interface and Diagnostics (AID) Tool is a device that is a member of the Aurora network. The AID Tool is used to troubleshoot equipment which uses the Aurora control via Modbus RTU communication. The AID Tool provides diagnostics, fault management and system configuration capabilities to the Aurora family of controls. An AID Tool is recommended, although not required. The AID Tool simply plugs into the exterior of the cabinet in the AID Tool port

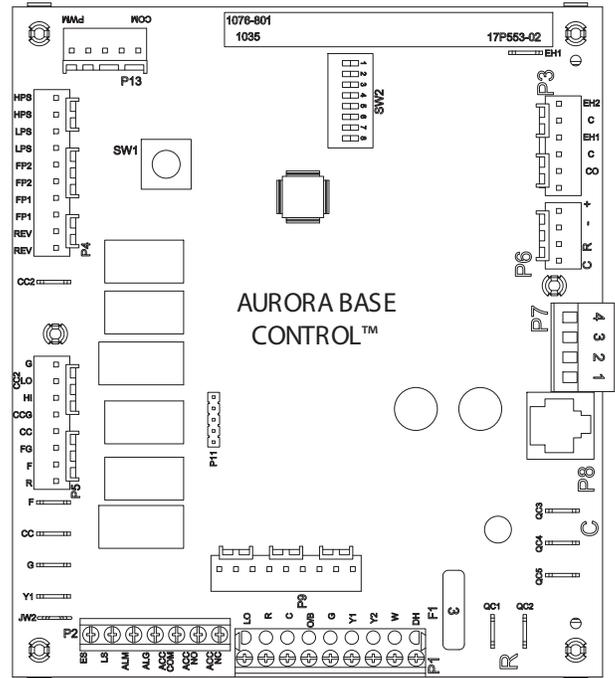

The Aurora 'Base' Control System cont.

Special Modes and Applications

5-Speed ECM Blower Motor

Normally the 5-Speed ECM motor can be driven off of thermostat signals and the ABC connector P9. Communicating thermostats, however present a special problem in this application since they operate without 24 VAC thermostat signals. The ABC board is wired to operate these systems from the alternate relay output signals CC1, CC2, Fan, and EH1 and should be wired for this.

Communicating Digital Thermostats

The Aurora controls system also features either mono-chromatic or color touch screen graphic display thermostats for user interface. These displays not only feature easy to use graphical interface but display alerts and faults in plain English.

Fault LED (LED1, Red)

Red Fault LED		LED Flash Code *	Lockout	Reset/ Remove	Fault Condition Summary
ABC Basic Faults	Normal - No Faults	Off	-		
	Fault-Input	1	No	Auto	Tstat input error. Autoreset upon condition removal.
	Fault-High Pressure	2	Yes	Hard or Soft	HP switch has tripped (>600 psi)
	Fault-Low Pressure	3	Yes	Hard or Soft	Low Pressure Switch has tripped (<40 psi for 30 continuous sec.)
	Fault-Freeze Detection FP2	4	Yes	Hard or Soft	Freeze protection sensor has tripped (<15 or 30 degF for 30 continuous sec.)
	Fault-Freeze Detection FP1	5	Yes	Hard or Soft	Freeze protection sensor has tripped (<15 or 30 degF for 30 continuous sec.)
	Fault-Condensate Overflow	7	Yes	Hard or Soft	Condensate switch has shown continuity for 30 continuous sec.
	Fault-Over/Under Voltage	8	No	Auto	Instantaneous voltage is out of range. **Controls shut down until resolved.
	Fault-FP1	11	Yes	Hard or Soft	FP1 Sensor Error (open or shorted)
	Fault-CritComErr	19	No	Auto	Any critical com error. Auto reset upon condition removal

NOTES:

*All codes >11 use long flash for tens digit and short flash for the ones digit.

Alert' is a noncritical sensor or function that has failed. Normal operation of the heat pump is maintained but service is desired at some point.

Operation Logic Data Table

Operation Logic Table	Heating					Cooling		
	STG1	STG2	STG3	EMERG	Fan Only	STG1	STG2	Fan Only
Compressor	On	On	On	Off	Off	On	On	Off
Reversing Valve	Off	Off	Off	Off	Off	On	On	On
Aux Heat	Off	Off	Staged	Staged	Off	Off	Off	Off
Acc Relay	On	On	On	Off	Off	On	On	Off
5 Speed ECM	Med Low	Med High	High	High	Low	Med Low	Med High	Low
T-Stat Signal	Y1	Y1,Y2	Y1,Y2,W	W	G	Y1,O	Y1,Y2,O	G

2/13/2012

Water Quality

In ground water situations where scaling could be heavy or where biological growth such as iron bacteria will be present, a closed loop system is recommended. The heat exchanger coils in ground water systems may, over a period of time, lose heat exchange capabilities due to a buildup of mineral deposits inside. These can be cleaned, but only by a qualified service mechanic, as special solutions and pumping equipment are required.

Hot water generator coils can likewise become scaled and possibly plugged. In areas with extremely hard water, the owner should be informed that the heat exchanger may require occasional flushing. Units with cupronickel heat exchangers are recommended for open loop applications due to the increased resistance to build-up and corrosion, along with reduced wear caused by acid cleaning. Failure to adhere to the guidelines in the water quality table could result in the loss of warranty.

Water Quality

It is the responsibility of the system designer and installing contractor to ensure that acceptable water quality is present and that all applicable codes have been met in these installations. Failure to adhere to the guidelines in the water quality table could result in loss of warranty. In ground water situations where scaling could be heavy or where biological growth such as iron bacteria will be present, a closed loop system is recommended. The heat exchanger coils in ground water systems may, over a period of time, lose heat exchange capabilities due to a buildup of mineral deposits inside. These can be cleaned, but only by a qualified service mechanic, as special solutions and pumping equipment are required. Hot water generator coils can likewise become scaled and possibly plugged. In areas with extremely hard water, the owner should be informed that the heat exchanger may require occasional flushing.

Units with cupronickel heat exchangers are recommended for open loop applications due to the increased resistance to build-up

and corrosion, along with reduced wear caused by acid cleaning. Failure to adhere to the guidelines in the water quality table could result in the loss of warranty.

Water Treatment

Do not use untreated or improperly treated water. Equipment damage may occur. The use of improperly treated or untreated water in this equipment may result in scaling, erosion, corrosion, algae or slime. Purchase of a pre-mix antifreeze could significantly improve system reliability if the water quality is controlled and there are additives in the mixture to inhibit corrosion. There are many examples of such fluids on the market today such as Environol™ 1000 (pre-mix ethanol), and others. The services of a qualified water treatment specialist should be engaged to determine what treatment, if any, is required. The product warranty specifically excludes liability for corrosion, erosion or deterioration of equipment.

The heat exchangers and water lines in the units are copper or cupronickel tube. There may be other materials in the buildings piping system that the designer may need to take into consideration when deciding the parameters of the water quality. If antifreeze or water treatment solution is to be used, the designer should confirm it does not have a detrimental effect on the materials in the system.

Contaminated Water

In applications where the water quality cannot be held to prescribed limits, the use of a secondary or intermediate heat exchanger is recommended to separate the unit from the contaminated water. The table on the next page outlines the water quality guidelines for unit heat exchangers. If these conditions are exceeded, a secondary heat exchanger is required. Failure to supply a secondary heat exchanger where needed will result in a warranty exclusion for primary heat exchanger corrosion or failure.

Material		Copper	90/10 Cupro-Nickel	316 Stainless Steel
pH	Acidity/Alkalinity	7 - 9	7 - 9	7 - 9
Scaling	Calcium and Magnesium Carbonate	(Total Hardness) less than 350 ppm	(Total Hardness) less than 350 ppm	(Total Hardness) less than 350 ppm
Corrosion	Hydrogen Sulfide	Less than .5 ppm (rotten egg smell appears at 0.5 PPM)	10 - 50 ppm	Less than 1 ppm
	Sulfates	Less than 125 ppm	Less than 125 ppm	Less than 200 ppm
	Chlorine	Less than .5 ppm	Less than .5 ppm	Less than .5 ppm
	Chlorides	Less than 20 ppm	Less than 125 ppm	Less than 300 ppm
	Carbon Dioxide	Less than 50 ppm	10 - 50 ppm	10- 50 ppm
	Ammonia	Less than 2 ppm	Less than 2 ppm	Less than 20 ppm
	Ammonia Chloride	Less than .5 ppm	Less than .5 ppm	Less than .5 ppm
	Ammonia Nitrate	Less than .5 ppm	Less than .5 ppm	Less than .5 ppm
	Ammonia Hydroxide	Less than .5 ppm	Less than .5 ppm	Less than .5 ppm
	Ammonia Sulfate	Less than .5 ppm	Less than .5 ppm	Less than .5 ppm
	Total Dissolved Solids (TDS)	Less than 1000 ppm	1000-1500 ppm	1000-1500 ppm
	LSI Index	+0.5 to -.05	+0.5 to -.05	+0.5 to -.05
Iron Fouling	Iron, Fe ²⁺ (Ferrous) Bacterial Iron Potential	< .2ppm	< .2 ppm	< .2 ppm
(Biological Growth)	Iron Oxide	Less than 1 ppm. Above this level deposition will occur.	Less than 1 ppm. Above this level deposition will occur.	Less than 1 ppm. Above this level deposition will occur.
Erosion	Suspended Solids	Less than 10 ppm and filtered for max of 600 micron size	Less than 10 ppm and filtered for max of 600 micron size	Less than 10 ppm and filtered for max of 600 micron size
	Threshold Velocity (Fresh Water)	< 6 ft/sec	< 6 ft/sec	<6 ft/sec

NOTE: Grains = PPM divided by 17 • mg/l is equivalent to PPM

7/17/14

Vertical Dimensional Data

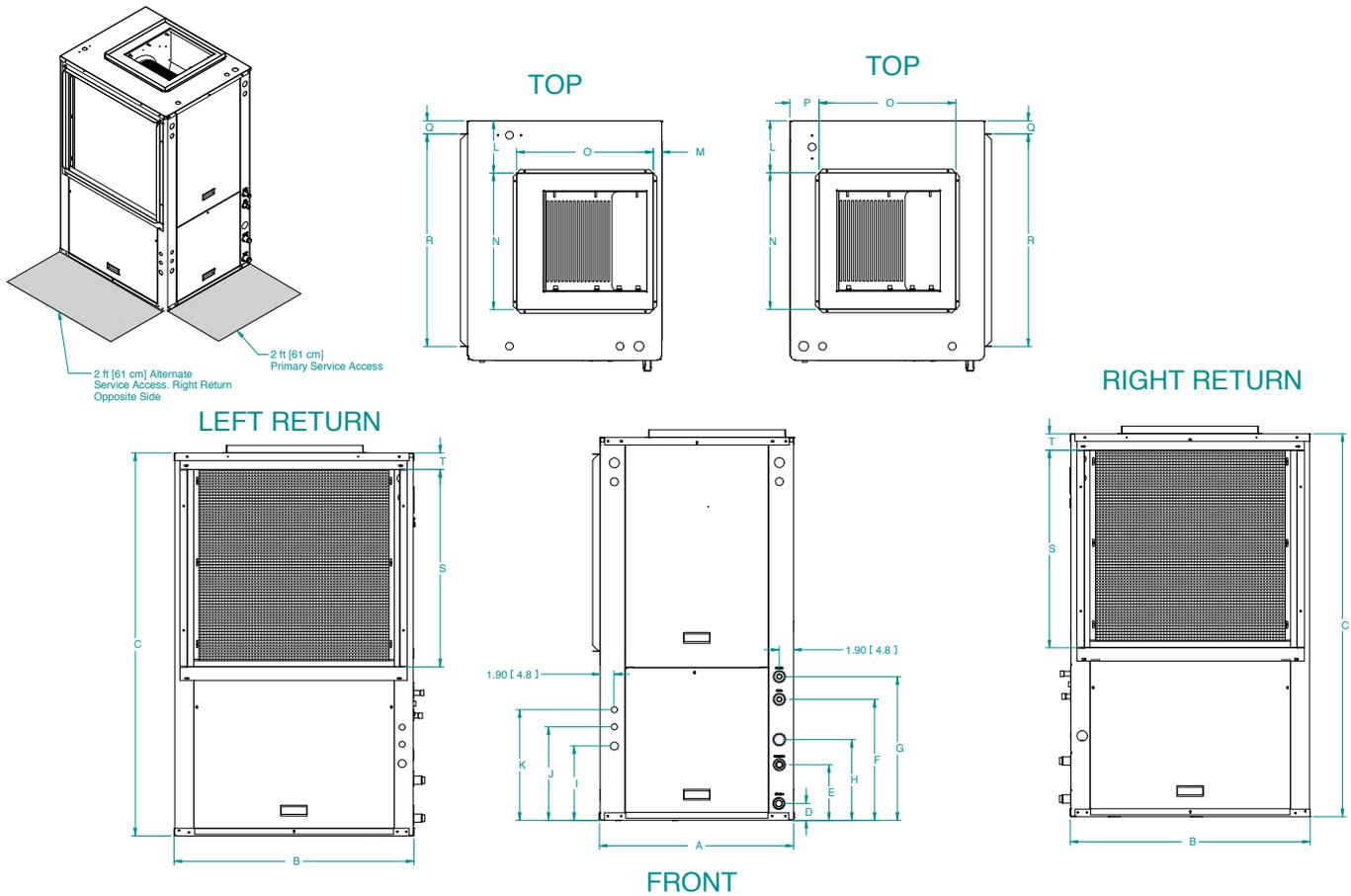

Vertical Top Flow Model	Overall Cabinet			Water Connections								Electrical Connections			Discharge Connection					Return Connection			
	A	B	C	D	E	F	G	H	Loop Water FPT	HWG Sweat (I.D.)	I 3/4" cond Power Supply	J 1/2" cond Ext Pump	K 1/2" cond Low Voltage	Duct Flange Installed					Return Duct Flanges				
														L	M	N	O	P	Q	R	S	T	
	Width	Depth	Height	Loop In	Loop Out	HWG In	HWG Out	Condensate	Supply Width	Supply Depth	Return Depth	Return Height											
024	in.	22.5	26.5	39.4	2.3	5.3	13.4	16.4	9.6	1"	1/2"	8.9	11.4	13.7	6.3	0.7	14.0	14.0	2.7	2.3	22.0	18.0	1.8
	cm.	57.2	67.3	100.1	5.8	13.5	34.0	41.7	24.4	Swivel	female	22.6	29.0	34.8	16.0	1.8	35.6	35.6	6.9	5.8	55.9	45.7	4.6
036	in.	22.5	26.5	44.5	2.0	7.0	13.5	16.5	10.2	1"	1/2"	9.5	12.1	14.3	6.1	0.8	14.0	14.0	4.4	2.4	22.0	22.0	2.0
	cm.	57.2	67.3	113.0	5.1	17.8	34.3	41.9	25.9	Swivel	female	24.1	30.7	36.3	15.5	2.0	35.6	35.6	11.2	6.1	55.9	55.9	5.1
048-060	in.	25.6	31.6	50.4	2.3	7.3	15.9	18.9	10.6	1"	1/2"	9.8	12.3	14.6	6.9	1.1	18.0	18.0	3.8	1.7	28.0	26.0	1.7
	cm.	65.0	80.3	128.0	5.8	18.5	40.4	48.0	26.9	Swivel	female	24.9	31.2	37.1	17.5	2.8	45.7	45.7	9.7	4.3	71.1	66.0	4.3
072	in.	25.6	31.6	54.4	2.3	7.3	15.9	18.9	10.6	1"	1/2"	9.8	12.3	14.6	6.9	1.1	18.0	18.0	3.8	1.7	28.1	30.0	2.2
	cm.	65.0	80.3	138.2	5.8	18.5	40.4	48.0	26.9	Swivel	female	24.9	31.2	37.1	17.5	2.8	45.7	45.7	9.7	4.3	71.4	76.2	5.6

Condensate is 3/4" PVC female glue socket and is switchable from side to front
 Unit shipped with 1" [25.4mm] return duct flanges and are suitable for duct connection.
 Discharge flange is field installed and extends 1" [25.4mm] from cabinet
 Water connections extend 1.2" [30.5mm] beyond front of cabinet.
 The optional 1" filter rack (not shown) has the same return opening connection size as the duct flanges shown in the drawing. The filter rack extends 2.25"(57.1 mm) from the unit.
 The optional 1" filter rack is suitable for duct connection.
 The optional filter rails (not shown) extend 1.25" (31.75 mm) from cabinet.

7/17/14

Horizontal Dimensional Data

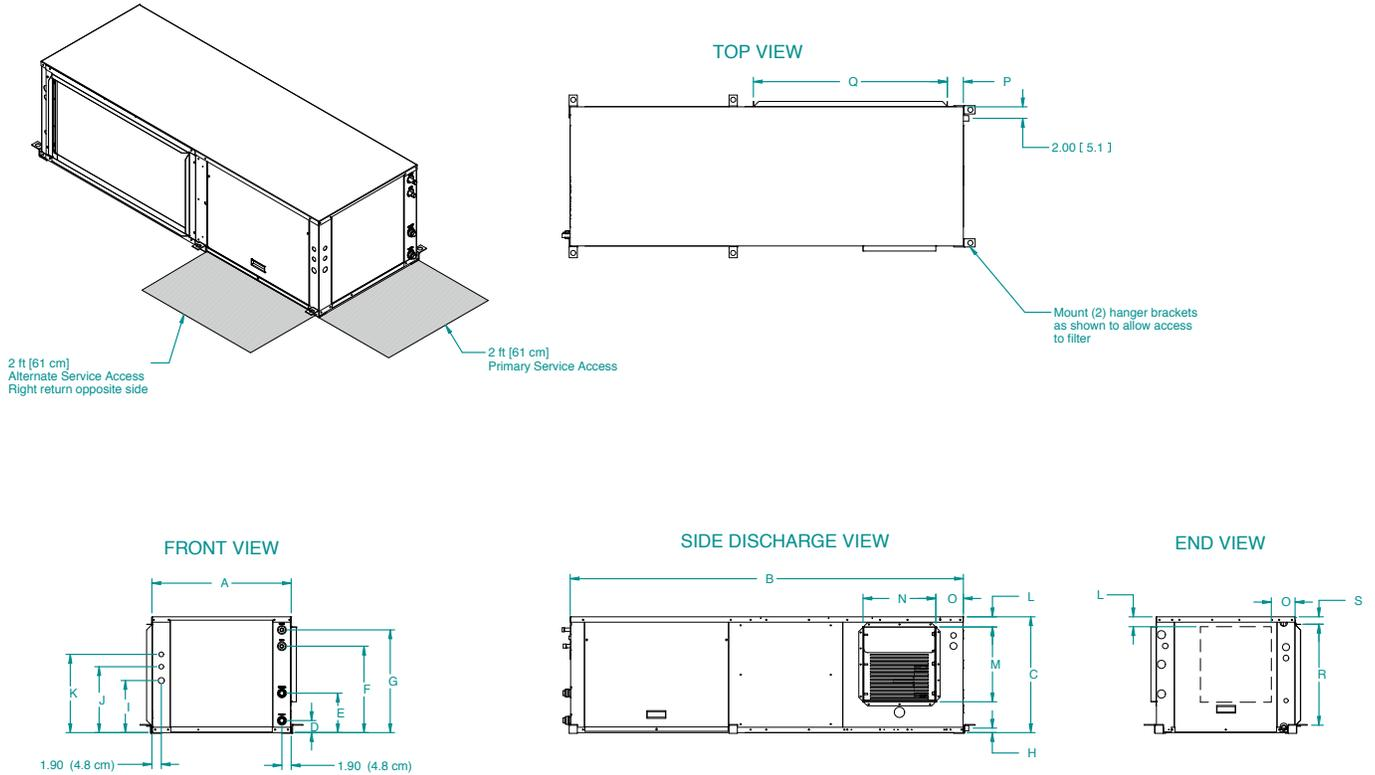

Horizontal Model	Overall Cabinet			Water Connections								Electrical Connections			Discharge Connection Duct Flange Installed				Return Connection Return Duct Flanges			
	A	B	C	D	E	F	G	H	Loop Water FPT	HWG Sweat (I.D.)	I	J	K	L*	M	N	O*	P	Q	R	S	
	Width	Depth	Height	In	Out	HWG In	HWG Out	Condensate			3/4" cond	1/2" cond	1/2" cond									Power Supply
	in.	cm.	in.	cm.	in.	cm.	in.	cm.	in.	cm.	in.	cm.	in.	cm.	in.	cm.	in.	cm.	in.	cm.	in.	cm.
024	in.	22.5	53.0	19.3	2.3	5.3	13.8	16.8	0.8	1"	1/2"	8.9	11.5	13.7	1.7	10.5	9.5	8.2	2.2	21.8	16.5	1.5
	cm.	57.2	134.6	49.0	5.8	13.5	35.1	42.7	2.0	Swivel	female	22.6	29.2	34.8	4.3	26.7	24.1	20.8	5.6	55.4	41.9	3.8
036	in.	22.5	63.0	19.3	2.3	7.3	13.5	16.5	0.8	1"	1/2"	9.5	12.1	14.3	2.3	10.5	9.5	5.7	2.8	30.5	16.7	1.3
	cm.	57.2	160.0	49.0	5.8	18.5	34.3	41.9	2.0	Swivel	female	24.1	30.7	36.3	5.8	26.7	24.1	14.5	7.1	77.5	42.4	3.3
048-060	in.	25.6	72.0	21.3	2.3	7.3	15.9	18.9	0.8	1"	1/2"	9.5	12.1	14.3	1.9	13.6	13.2	5.0	2.9	35.5	18.6	1.3
	cm.	65.0	182.9	54.1	5.8	18.5	40.4	48.0	2.0	Swivel	female	24.1	30.7	36.3	4.8	34.5	33.5	12.7	7.4	90.2	47.2	3.3
072	in.	25.6	77.0	21.3	2.3	7.3	15.9	18.9	0.8	1"	1/2"	9.5	12.1	14.3	1.9	13.6	13.2	5.0	2.8	40.4	18.7	1.5
	cm.	65.0	195.6	54.1	5.8	18.5	40.4	48.0	2.0	Swivel	female	24.1	30.7	36.3	4.8	34.5	33.5	12.7	7.1	102.6	47.5	3.8

* Dimensions shown are for left return side discharge other configurations shown in tables below

Condensate is 3/4" PVC female glue socket and is switchable from side to front

Unit shipped with 1" [25.4mm] return duct flanges suitable for duct connection.

Discharge flange is field installed and extends 1" [25.4mm] from cabinet

Water connections extend 1.2" [30.5mm] beyond front of cabinet.

The optional 1" filter rack (not shown) has the same return opening connection size as the duct flanges shown in the drawing. The filter rack extends 2.25" (57.1 mm) from the unit.

The optional 1" filter rack is suitable for duct connection.

The optional filter rails (not shown) extend 1.25" (31.75 mm) from cabinet.

The 024 model is not field convertible changing from end to side discharge. It requires an additional discharge panel (not supplied).

7/17/14

024 Model			L	O	036 Model			L	O	048-060 Models			L	O	072 Model			L	O
Right Return End Discharge	in	2.2	5.7	in	6.5	6.6	in	1.9	5.0	in	1.9	5.0	in	1.9	5.0				
	cm	5.6	14.5		cm	16.5		16.8	cm		4.8	12.7		cm	4.8	12.7			
Right Return Side Discharge	in	6.9	8.3	in	2.3	5.7	in	5.7	5.0	in	5.7	5.0	in	5.7	5.0				
	cm	17.5	21.1		cm	5.8		14.5	cm		14.5	12.7		cm	14.5	12.7			
Left Return End Discharge	in	6.5	7.3	in	6.5	6.6	in	5.7	4.9	in	5.7	4.9	in	5.7	5.0				
	cm	16.5	18.5		cm	16.5		16.8	cm		14.5	12.4		cm	14.5	12.4			

Physical Data

Model		Dual Capacity				
		024	036	048	060	072
Compressor (1 each)		Copeland Ultra Tech, Dual Capacity Scroll				
Factory Charge R410a, oz [kg]	Vertical	39 [1.05]	52 [1.47]	68 [1.93]	76 [2.15]	88 [2.49]
Factory Charge R410a, oz [kg]	Horizontal	38 [1.08]	52 [1.47]	68 [1.93]	72 [2.04]	85 [2.41]
ECM Blower Motor & Blower						
Blower Motor Type/Speeds	ECM	5 Speed ECM				
Blower Motor- hp [W]	ECM	1/2 [373]	1/2 [373]	1 [746]	1 [746]	1 [746]
Blower Wheel Size (Dia x W), in. [mm]	ECM	9 x 7 [229 x 178]	9 x 7 [229 x 178]	11 x 10 [279 x 254]	11 x 10 [279 x 254]	11 x 10 [279 x 254]
Coax and Water Piping						
Water Connections Size - Swivel - in [mm]		1" [25.4]	1" [25.4]	1" [25.4]	1" [25.4]	1" [25.4]
HWG Connection Size - Female Sweat I.D. - in [mm]		1/2" [12.7]	1/2" [12.7]	1/2" [12.7]	1/2" [12.7]	1/2" [12.7]
Coax & Piping Water Volume - gal [l]		.35 [1.3]	.7 [2.6]	.7 [2.6]	1.3 [4.9]	1.6 [6.1]
Vertical						
Air Coil Dimensions (H x W), in. [mm]		19 x 20 [483 x 508]	24 x 20 [610 x 508]	28 x 25 [711 x 635]	28 x 25 [711 x 635]	32 x 25 [813 x 635]
Air Coil Total Face Area, ft ² [m ²]		2.6 [0.245]	3.3 [0.310]	4.9 [0.452]	4.9 [0.452]	5.6 [0.516]
Air Coil Tube Size, in [mm]		3/8 [9.5]	3/8 [9.5]	3/8 [9.5]	3/8 [9.5]	3/8 [9.5]
Air Coil Number of rows		3	3	3	3	3
Optional Filter - 1" [25mm] Pleated MERV8 Throwaway, in [mm]		20 x 24 [508 x 610]	24 x 24 [610 x 610]	28 x 30 [711 x 762]	28 x 30 [711 x 762]	30 x 32 [762 x 813]
Weight - Operating, lb [kg]		198 [90]	221 [100]	303 [137]	329 [149]	350 [159]
Weight - Packaged, lb [kg]		218 [99]	241 [109]	323 [147]	349 [158]	370 [168]
Horizontal						
Air Coil Dimensions (H x W), in. [mm]		18 x 21 [457 x 533]	18 x 27 [457 x 686]	20 x 35 [508 x 889]	20 x 35 [508 x 889]	20 x 40 [508 x 1016]
Air Coil Total Face Area, ft ² [m ²]		2.6 [.244]	3.4 [0.314]	4.9 [0.452]	4.9 [0.452]	5.6 [0.516]
Air Coil Tube Size, in [mm]		3/8 [9.5]	3/8 [9.5]	3/8 [9.5]	3/8 [9.5]	3/8 [9.5]
Air Coil Number of rows		3	3	3	3	3
Optional Filter - 1" [25mm] Pleated MERV8 Throwaway, in [mm]		1 - 18 x 24 [457 x 610]	1 - 18 x 32 [457 x 813]	1 - 20 x 37 [508 x 940]	1 - 20 x 37 [508 x 940]	1 - 20 x 20 [508 x 508] 1 - 20 x 22 [508 x 559]
Weight - Operating, lb [kg]		228 [103]	250 [113]	325 [147]	358 [162]	369 [167]
Weight - Packaged, lb [kg]		248 [112]	270 [122]	345 [156]	378 [171]	389 [176]

12/14/2016

Auxiliary Heat Ratings

Model	KW		Stages	BTU/HR		Min CFM			
	208V	230V		208V	230V		024	036	048 - 072
EAM(H)5*	3.6	4.8	1	12,300	16,300	450	●	●	
EAM(H)8*	5.7	7.6	2	19,400	25,900	550	●	●	
EAM(H)10*	7.2	9.6	2	24,600	32,700	650	●	●	
EAL(H)10*	7.2	9.6	2	24,600	32,700	1100			●
EAL(H)15*	10.8	14.4	2	36,900	49,100	1250			●
EAL(H)20*	14.4	19.2	2	49,200	65,500	1500			●

Order the "H" part number when installed on horizontal units

6/9/2014

Air flow level for auxiliary heat (Aux) must be equal to or above the minimum CFM in this table

Auxiliary Heat Electrical Data

Model	Supply Circuit	Heater Amps		Min Circuit Amp		Fuse (USA)		Fuse (CAN)		CKT BRK	
		208 V	240 V	208 V	240 V	208 V	240 V	208 V	240 V	208 V	240 V
EAM(H)5*	Single	17.3	20.0	26.7	30.0	30	30	30	30	30	30
EAM(H)8*	Single	27.5	31.7	39.3	44.6	40	45	40	45	40	45
EAM(H)10*	Single	34.7	40.0	48.3	55.0	50	60	50	60	50	60
EAL(H)10*	Single	34.7	40.0	53.3	60.0	60	60	60	60	60	60
EAL(H)15*	Single	52.0	60.0	75.0	85.0	80	90	80	90	70	100
	L1/L2	34.7	40.0	53.3	60.0	60	60	60	60	60	60
	L3/L4	17.3	20.0	21.7	25.0	25	25	25	25	20	30
EAL(H)20*	Single	69.3	80.0	96.7	110.0	100	110	100	110	100	100
	L1/L2	34.7	40.0	53.3	60.0	60	60	60	60	60	60
	L3/L4	34.7	40.0	43.3	50.0	45	50	45	50	40	50

All heaters rated single phase 60 cycle and include unit fan load

3/10/14

All fuses type "D" time delay (or HACR circuit breaker in USA)

Supply wire size to be determined by local codes

Electrical Data

Dual Capacity Unit with 5 Speed ECM Motor

Model	Rated Voltage	Voltage Min/Max	Compressor				HWG Pump FLA	Ext Loop FLA	Blower Motor FLA	Total Unit FLA	Min Circ Amp	Max Fuse/HACR
			MCC	RLA	LRA	LRA**						
024	208-230/60/1	187/253	18.2	11.6	58.3	21.0	0.4	5.4	4.1	21.5	24.5	35
036	208-230/60/1	187/253	23.8	15.2	83.0	30.0	0.4	5.4	4.1	25.1	28.9	40
048	208-230/60/1	187/253	33.0	21.1	104.0	37.0	0.4	5.4	7.6	34.5	39.8	60
060	208-230/60/1	187/253	42.3	27.1	152.9	54.0	0.4	5.4	7.6	40.5	47.2	70
072	208-230/60/1	187/253	46.3	29.6	179.2	63.0	0.4	5.4	7.6	43.0	50.4	80

**With optional IntelliStart

Rated Voltage of 208/230/60/1

HACR circuit breaker in USA only

All fuses Class RK-5

6/9/14

Blower Performance Data

5-Speed ECM Constant Torque Motors

The 5-Speed ECM is a 'Constant Torque' ECM motor and delivers air flow similar to a PSC but operates as efficiently as an ECM Motor. Because it's an ECM Motor, the 5-Speed ECM can ramp slowly up or down like the ECM motor. There are 5 possible speed taps available on the 5-Speed ECM motor with #1 being the lowest airflow and #5 being the highest airflow. These speed selections are preset at the time of manufacture and are easily changed in the field if necessary.

If more than one tap are energized at the same time, built in logic gives precedence to the highest tap number and allows air flow to change with G, Y1, Y2 and W signals or with Fan, CC, CC2, and E1 output signals. Each of those 5 speeds has a specific 'Torque' value programmed into the motor for each speed selection.

As static pressure increases, airflow decreases resulting in less torque on the rotor. The motor responds only to changes in torque and adjusts its speed accordingly.

The 5-Speed ECM motor is powered by line voltage but the motor speed is energized by 24 VAC.

5-Speed ECM Benefits:

- High efficiency
- Soft start
- 5 speeds with up to 4 speeds on-line
- Built in logic allows air flow to change with G, Y1, Y2 and W signals
- Super efficient low airflow continuous blower setting (G)

Blower Performance Data cont.

Dual Capacity with 5-Speed ECM

Model	Motor Speed	Motor Tap	T'stat Cnct.	Blower Size	Motor HP	Airflow (cfm) at External Static Pressure (in. wg)															
						0	0.05	0.1	0.15	0.2	0.25	0.3	0.35	0.4	0.45	0.5	0.6	0.7	0.8	0.9	1.00
024	High	5	W	9 x 7	1/2	1024	1013	1002	988	974	963	951	940	929	901	872	785	691	-	-	-
	Med High	4	Y2			932	917	902	892	882	867	851	842	832	817	802	756	661	-	-	-
	Med	3				835	826	816	801	785	772	759	749	738	719	700	677	636	-	-	-
	Med Low	2	Y1			765	747	729	720	710	696	681	662	643	627	611	581	515	-	-	-
	Low	1	G			665	656	647	626	605	593	580	561	541	519	496	443	392	-	-	-
036	High	5	W	9 x 7	1/2	1325	1319	1313	1293	1272	1242	1212	1158	1103	1058	1013	930	839	-	-	-
	Med High	4	Y2			1279	1267	1254	1238	1222	1203	1184	1137	1089	1049	1008	926	836	-	-	-
	Med	3				1229	1218	1206	1187	1167	1154	1140	1110	1079	1044	1008	929	829	-	-	-
	Med Low	2	Y1			1201	1184	1167	1156	1145	1129	1113	1086	1058	1028	997	914	808	-	-	-
	Low	1	G			1007	989	971	958	945	925	904	889	873	862	850	818	778	-	-	-
048	High	5	W	11 x 10	1	1890	1874	1857	1845	1833	1809	1784	1769	1754	1736	1718	1672	1629	1601	1562	1522
	Med High	4	Y2			1769	1754	1739	1721	1703	1685	1666	1645	1623	1604	1585	1539	1499	1463	1432	1376
	Med	3				1671	1652	1632	1614	1595	1576	1557	1536	1514	1494	1474	1430	1387	1351	1313	1173
	Med Low	2	Y1			1574	1555	1535	1514	1492	1472	1452	1431	1410	1387	1363	1330	1284	1236	1108	1014
	Low	1	G			1388	1370	1352	1322	1292	1264	1236	1216	1195	1178	1161	1095	984	916	842	787
060	High	5	W	11 x 10	1	2077	2066	2055	2044	2033	2017	2000	1966	1931	1904	1877	1841	1810	1791	1740	1653
	Med High	4	Y2			1948	1937	1925	1910	1895	1880	1865	1831	1797	1778	1759	1720	1707	1680	1660	1612
	Med	3				1810	1794	1778	1739	1700	1684	1667	1657	1646	1629	1612	1576	1583	1547	1510	1480
	Med Low	2	Y1			1680	1667	1653	1618	1583	1562	1540	1522	1503	1488	1473	1465	1449	1410	1369	1319
	Low	1	G			1594	1572	1550	1512	1474	1450	1426	1410	1393	1385	1376	1351	1325	1290	1168	1085
072	High	5	W	11 x 10	1	2402	2388	2373	2358	2343	2334	2325	2307	2289	2274	2258	2215	2177	2125	2052	1933
	Med High	4	Y2			2209	2193	2177	2164	2151	2135	2118	2105	2092	2072	2052	2017	1982	1954	1925	1844
	Med	3				2085	2072	2058	2045	2031	2010	1989	1972	1954	1936	1918	1881	1852	1821	1790	1751
	Med Low	2	Y1			1961	1951	1940	1926	1911	1885	1859	1844	1829	1814	1798	1759	1727	1703	1670	1636
	Low	1	G			1767	1751	1735	1715	1694	1678	1661	1640	1619	1602	1584	1548	1512	1475	1426	1397

Factory speed settings are in Bold

Air flow values are with dry coil and standard filter

For wet coil performance first calculate the face velocity of the air coil (Face Velocity [fpm] = Airflow [cfm] / Face Area [sq ft]).

Then for velocities of 200 fpm reduce the static capability by 0.03 in. wg, 300 fpm by 0.08 in. wg, 400 fpm by 0.12 in. wg., and 500 fpm by 0.16 in. wg.

Highest setting is for auxiliary heat (W) and lowest setting is for constant blower (G). The "Y1" and "Y2" settings must be between the "G" and "W" settings.

7/30/14

Setting Blower Speed - 5-Speed ECM

5-Speed ECM blower motors have five (5) speeds of which four (4) are selectable on dual capacity.

 **CAUTION: Disconnect all power before performing this operation.**

5-Speed ECM Motor Connections - Dual Capacity

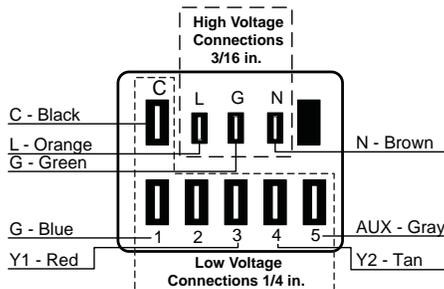

Reference Calculations

Heating Calculations:	Cooling Calculations:
$LWT = EWT - \frac{HE}{gpm \times 500}$	$LWT = EWT + \frac{HR}{gpm \times 500}$
$LAT = EAT + \frac{HC}{cfm \times 1.08}$	$LAT (DB) = EAT (DB) - \frac{SC}{cfm \times 1.08}$
$TH = HC + HW$	$LC = TC - SC$
	$S/T = \frac{SC}{TC}$

Legend and Notes

Abbreviations and Definitions

cfm = airflow, cubic feet/minute
 EWT = entering water temperature, Fahrenheit
 gpm = water flow in gallons/minute
 WPD = water pressure drop, psi and feet of water
 EAT = entering air temperature, Fahrenheit (dry bulb/wet bulb)
 HC = air heating capacity, MBtu/h
 TC = total cooling capacity, MBtu/h
 SC = sensible cooling capacity, MBtu/h
 kW = total power unit input, kilowatts
 HR = total heat of rejection, MBtu/h
 HE = total heat of extraction, MBtu/h

HWC = hot water generator capacity, MBtu/h
 EER = Energy Efficient Ratio
 = Btu output/Watt input
 COP = Coefficient of Performance
 = Btu output/Btu input
 LWT = leaving water temperature, °F
 LAT = leaving air temperature, °F
 TH = total heating capacity, MBtu/h
 LC = latent cooling capacity, MBtu/h
 S/T = sensible to total cooling ratio

Notes to Performance Data Tables

The following notes apply to all performance data tables:

- Performance ratings are based on 80°F DB/67°F WB EAT for cooling and 70°F DB EAT for heating.
- Three flow rates are shown for each unit. The lowest flow rate shown is used for geothermal open loop/well water systems with a minimum of 50°F EWT. The middle flow rate shown is the minimum geothermal closed loop flow rate. The highest flow rate shown is optimum for geothermal closed loop systems and the suggested flow rate for boiler/tower applications.
- The hot water generator numbers are based on a flow rate of 0.4 gpm/ton of rated capacity with an EWT of 90°F.
- Entering water temperatures below 40°F assumes 15% antifreeze solution.
- For non-standard EAT conditions, apply the appropriate Correction Factor tables.
- Interpolation between EWT, gpm, and cfm data is permissible, extrapolation is not.

Operating Limits

Operating Limits	Cooling		Heating	
	(°F)	(°C)	(°F)	(°C)
Air Limits				
Min. Ambient Air	45	7.2	45	7.2
Rated Ambient Air	80	26.7	70	21.1
Max. Ambient Air	100	37.8	85	29.4
Min. Entering Air	50	10.0	40	4.4
Rated Entering Air db/wb	80.6/66.2	27/19	68	20.0
Max. Entering Air db/wb	110/83	43/28.3	80	26.7
Water Limits				
Min. Entering Water	30	-1.1	20	-6.7
Normal Entering Water	50-110	10-43.3	30-70	-1.1
Max. Entering Water	120	48.9	90	32.2

Notes: Minimum/maximum limits are only for start-up conditions, and are meant for bringing the space up to occupancy temperature. Units are not designed to operate at the minimum/maximum conditions on a regular basis. The operating limits are dependent upon three primary factors: 1) water temperature, 2) return air temperature, and 3) ambient temperature. When any of the factors are at the minimum or maximum levels, the other two factors must be at the normal level for proper and reliable unit operation.

Antifreeze Corrections

Catalog performance can be corrected for antifreeze use. Please use the following table and note the example given.

Antifreeze Type EWT - °F [°C]	Antifreeze % by wt	Heating 30 [-1.1]	Cooling 90 [32.2]	Pressure Drop 30 [-1.1]
Water	0	1.000	1.000	1.000
Ethylene Glycol	10	0.973	0.991	1.075
	20	0.943	0.979	1.163
	30	0.917	0.965	1.225
	40	0.890	0.955	1.324
	50	0.865	0.943	1.419
Propylene Glycol	10	0.958	0.981	1.130
	20	0.913	0.969	1.270
	30	0.854	0.950	1.433
	40	0.813	0.937	1.614
	50	0.770	0.922	1.816
Ethanol	10	0.927	0.991	1.242
	20	0.887	0.972	1.343
	30	0.856	0.947	1.383
	40	0.815	0.930	1.523
	50	0.779	0.911	1.639
Methanol	10	0.957	0.986	1.127
	20	0.924	0.970	1.197
	30	0.895	0.951	1.235
	40	0.863	0.936	1.323
	50	0.833	0.920	1.399



WARNING: Gray area represents antifreeze concentrations greater than 35% by weight and should be avoided due to the extreme performance penalty they represent.

Antifreeze Correction Example

Antifreeze solution is Propylene Glycol 20% by weight. Determine the corrected heating and cooling performance at 30°F and 90°F respectively as well as pressure drop at 30°F for a 036.

The corrected cooling capacity at 90°F would be: 34,800 Btu/h x 0.969 = 33,721 Btu/h

The corrected heating capacity at 30°F would be: 29,300 Btu/h x 0.913 = 26,750 Btu/h

The corrected pressure drop at 30°F and 9 gpm would be: 13.4 feet of head x 1.270 = 17.02 feet of head

Correction Factor Tables

Air Flow Corrections (Dual Capacity Part Load)

Airflow		Cooling				Heating		
cfm Per Ton of Clg	% of Nominal	Total Cap	Sens Cap	Power	Heat of Rej	Htg Cap	Power	Heat of Ext
240	60	0.922	0.778	0.956	0.924	0.943	1.239	0.879
275	69	0.944	0.830	0.962	0.944	0.958	1.161	0.914
300	75	0.957	0.866	0.968	0.958	0.968	1.115	0.937
325	81	0.970	0.900	0.974	0.970	0.977	1.075	0.956
350	88	0.982	0.933	0.981	0.980	0.985	1.042	0.972
375	94	0.991	0.968	0.991	0.991	0.993	1.018	0.988
400	100	1.000	1.000	1.000	1.000	1.000	1.000	1.000
425	106	1.007	1.033	1.011	1.008	1.007	0.990	1.010
450	113	1.013	1.065	1.023	1.015	1.012	0.987	1.018
475	119	1.017	1.099	1.037	1.022	1.018	0.984	1.025
500	125	1.020	1.132	1.052	1.027	1.022	0.982	1.031
520	130	1.022	1.159	1.064	1.030	1.025	0.979	1.034

5/30/06

Air Flow Corrections (Dual Capacity Full Load and Single Speed)

Airflow		Cooling				Heating		
cfm Per Ton of Clg	% of Nominal	Total Cap	Sens Cap	Power	Heat of Rej	Htg Cap	Power	Heat of Ext
240	60	0.922	0.786	0.910	0.920	0.943	1.150	0.893
275	69	0.944	0.827	0.924	0.940	0.958	1.105	0.922
300	75	0.959	0.860	0.937	0.955	0.968	1.078	0.942
325	81	0.971	0.894	0.950	0.967	0.977	1.053	0.959
350	88	0.982	0.929	0.964	0.978	0.985	1.031	0.973
375	94	0.992	0.965	0.982	0.990	0.993	1.014	0.988
400	100	1.000	1.000	1.000	1.000	1.000	1.000	1.000
425	106	1.007	1.034	1.020	1.010	1.007	0.990	1.011
450	113	1.012	1.065	1.042	1.018	1.013	0.983	1.020
475	119	1.017	1.093	1.066	1.026	1.018	0.980	1.028
500	125	1.019	1.117	1.092	1.033	1.023	0.978	1.034
520	130	1.020	1.132	1.113	1.038	1.026	0.975	1.038

Cooling Capacity Corrections

Entering Air WB °F	Total Clg Cap	Sensible Cooling Capacity Multipliers - Entering DB °F										Power Input	Heat of Rejection
		60	65	70	75	80	80.6	85	90	95	100		
55	0.898	0.723	0.866	1.048	1.185	*	*	*	*	*	*	0.985	0.913
60	0.912		0.632	0.880	1.078	1.244	1.260	*	*	*	*	0.994	0.927
63	0.945			0.768	0.960	1.150	1.175	*	*	*	*	0.996	0.954
65	0.976			0.694	0.881	1.079	1.085	1.270	*	*	*	0.997	0.972
66.2	0.983			0.655	0.842	1.040	1.060	1.232	*	*	*	0.999	0.986
67	1.000			0.616	0.806	1.000	1.023	1.193	1.330	1.480	*	1.000	1.000
70	1.053				0.693	0.879	0.900	1.075	1.205	1.404	*	1.003	1.044
75	1.168					0.687	0.715	0.875	1.040	1.261	1.476	1.007	1.141

NOTE: * Sensible capacity equals total capacity at conditions shown.

3/28/12

Heating Capacity Corrections

Ent Air DB °F	Heating Corrections		
	Htg Cap	Power	Heat of Ext
45	1.062	0.739	1.158
50	1.050	0.790	1.130
55	1.037	0.842	1.096
60	1.025	0.893	1.064
65	1.012	0.945	1.030
68	1.005	0.976	1.012
70	1.000	1.000	1.000
75	0.987	1.048	0.970
80	0.975	1.099	0.930

11/10/09

Pressure Drop

Model	GPM	Pressure Drop (psi)				
		30°F	50°F	70°F	90°F	110°F
024 Full Load	4	2.3	2.1	2.0	1.9	1.7
	6	4.5	4.3	4.0	3.7	3.5
	8	7.5	7.0	6.6	6.1	5.7
	10	10.5	9.7	9.9	8.5	7.9
024 Part Load	3	1.5	1.4	1.3	1.2	1.1
	5	3.3	3.1	2.9	2.7	2.5
	7	5.9	5.6	5.2	4.8	4.5
	9	8.5	8.1	8.2	6.9	6.5
036 Full Load	5	1.9	1.8	1.7	1.6	1.5
	7	3.6	3.4	3.2	3.0	2.9
	9	5.8	5.4	5.1	4.8	4.6
	11	8.0	7.4	7.4	6.6	6.3
036 Part Load	4	1.4	1.3	1.2	1.2	1.0
	6	2.7	2.6	2.4	2.3	2.1
	8	4.7	4.4	4.1	4.0	3.5
	10	6.7	6.2	6.2	5.7	4.9
048 Full Load	6	1.7	1.6	1.5	1.4	1.3
	9	3.9	3.6	3.4	3.2	3.1
	12	7.0	6.6	6.2	5.8	5.6
	15	10.1	9.6	9.8	8.4	8.1
048 Part Load	5	1.1	1.1	1.0	0.9	0.9
	8	3.1	2.9	2.7	2.5	2.3
	11	5.9	5.6	5.2	4.8	4.5
	14	8.7	8.3	8.5	7.1	6.7
060 Full Load	8	2.8	2.7	2.5	2.3	2.2
	12	5.8	5.4	5.1	4.8	4.4
	16	9.8	9.2	8.6	8.0	7.4
	20	13.8	13.0	13.0	11.2	10.4
060 Part Load	6	1.7	1.6	1.5	1.4	1.3
	10	4.2	4.0	3.7	3.4	3.2
	14	7.6	7.2	6.7	6.2	5.8
	18	11.0	10.4	10.7	9.0	8.4
072 Full Load	12	3.8	3.6	3.4	3.1	2.9
	15	5.7	5.3	5.0	4.7	4.3
	18	7.8	7.4	6.9	6.4	6.0
	21	9.9	9.5	9.1	8.1	7.7
072 Part Load	10	2.8	2.7	2.5	2.3	2.2
	13	4.4	4.2	3.9	3.6	3.4
	16	6.4	6.0	5.6	5.2	4.8
	19	8.4	7.8	7.6	6.8	6.2

7/18/14

Performance Data cont.

024 - Full Load Dual Capacity with 5-Speed ECM (800 cfm)

EWT °F	Flow gpm	WPD		HEATING - EAT 70°F							COOLING - EAT 80/67 °F										
		PSI	FT	Airflow cfm	HC Mbtu/h	Power kW	HE Mbtu/h	LAT °F	COP	HWC Mbtu/h	Airflow cfm	TC Mbtu/h	SC Mbtu/h	S/T Ratio	Power kW	HR Mbtu/h	EER	HWC Mbtu/h			
20	4.0	2.3	5.4	Operation not recommended							Operation not recommended										
	6.0	4.7	10.8	Operation not recommended							Operation not recommended										
	8.0	7.7	17.8	600	16.0	1.47	10.9	94.6	3.19	2.1	800	16.5	1.51	11.3	89.1	3.19	2.0				
30	4.0	2.3	5.3	Operation not recommended							Operation not recommended										
	6.0	4.5	10.5	600	18.3	1.51	13.2	98.3	3.56	2.3	600	24.7	17.0	0.69	1.00	28.1	24.7	-			
				800	18.9	1.56	13.5	91.8	3.55	2.1	800	25.1	18.6	0.74	1.05	28.7	23.8	-			
	8.0	7.5	17.3	600	18.6	1.52	13.4	98.8	3.58	2.3	600	24.8	17.0	0.69	0.97	28.1	25.6	-			
800				19.2	1.57	13.9	92.3	3.59	2.2	800	25.4	18.6	0.73	1.02	28.9	25.0	-				
40	4.0	2.2	5.1	Operation not recommended							Operation not recommended										
	6.0	4.4	10.2	600	20.9	1.58	15.5	102.2	3.86	2.5	600	25.0	17.2	0.69	1.10	28.7	22.7	-			
				800	21.5	1.62	16.0	94.9	3.90	2.3	800	25.4	18.8	0.74	1.15	29.4	22.1	-			
	8.0	7.3	16.8	600	21.3	1.60	15.8	102.9	3.90	2.6	600	25.2	17.2	0.68	1.07	28.8	23.6	-			
				800	22.0	1.63	16.4	95.4	3.94	2.4	800	25.7	18.8	0.73	1.12	29.5	23.1	-			
600				22.6	1.62	17.1	104.9	4.09	2.7	600	24.0	15.8	0.66	1.26	28.3	19.1	1.1				
50	4.0	2.1	4.9	800	23.3	1.64	17.7	96.9	4.15	2.5	800	25.2	17.6	0.70	1.32	29.8	19.1	1.2			
				600	23.4	1.66	17.8	106.2	4.14	2.8	600	24.5	16.0	0.65	1.19	28.5	20.7	1.0			
	6.0	4.3	9.9	800	24.2	1.68	18.4	98.0	4.22	2.6	800	25.8	17.8	0.69	1.24	30.0	20.7	1.2			
				600	24.0	1.67	18.2	107.0	4.20	2.9	600	24.7	17.1	0.69	1.16	28.7	21.4	1.0			
	8.0	7.0	16.3	800	24.7	1.69	18.9	98.6	4.27	2.6	800	26.0	19.0	0.73	1.22	30.2	21.4	1.1			
60	4.0	2.1	4.8	600	24.7	1.68	19.0	108.2	4.32	3.0	600	23.4	15.7	0.67	1.37	28.1	17.1	1.3			
				800	25.5	1.69	19.8	99.5	4.43	2.8	800	24.6	17.5	0.71	1.43	29.5	17.1	1.4			
	6.0	4.1	9.6	600	25.8	1.73	20.0	109.9	4.39	3.0	600	24.0	15.9	0.66	1.30	28.4	18.4	1.2			
				800	26.7	1.74	20.8	100.9	4.50	2.8	800	25.1	17.7	0.70	1.36	29.8	18.5	1.4			
	8.0	6.8	15.8	600	26.5	1.74	20.5	110.8	4.45	3.2	600	24.2	16.8	0.69	1.27	28.6	19.0	1.1			
				800	27.3	1.75	21.4	101.6	4.58	2.9	800	25.4	18.6	0.73	1.33	30.0	19.1	1.3			
70	4.0	2.0	4.6	600	26.9	1.74	21.0	111.5	4.54	3.2	600	22.9	15.6	0.68	1.49	28.0	15.4	1.6			
				800	27.8	1.74	21.9	102.2	4.69	3.0	800	23.9	17.4	0.73	1.54	29.2	15.5	1.7			
	6.0	4.0	9.2	600	28.3	1.79	22.1	113.6	4.62	3.4	600	23.5	15.8	0.67	1.42	28.4	16.5	1.5			
				800	29.2	1.79	23.1	103.8	4.77	3.1	800	24.5	17.5	0.72	1.47	29.5	16.6	1.7			
	8.0	6.6	15.3	600	29.0	1.82	22.8	114.7	4.68	3.5	600	23.7	16.5	0.69	1.39	28.5	17.1	1.4			
800				30.0	1.81	23.8	104.7	4.86	3.2	800	24.8	18.2	0.74	1.45	29.7	17.2	1.6				
80	4.0	1.9	4.5	600	28.9	1.80	22.8	114.6	4.71	3.6	600	21.9	15.5	0.71	1.63	27.5	13.4	2.0			
				800	29.9	1.78	23.8	104.6	4.91	3.3	800	22.8	17.2	0.75	1.68	28.5	13.5	2.1			
	6.0	3.9	8.9	600	30.6	1.87	24.2	117.1	4.79	3.7	600	22.5	15.7	0.70	1.58	27.9	14.3	1.9			
				800	31.6	1.85	25.3	106.6	5.00	3.5	800	23.4	17.4	0.74	1.62	29.0	14.4	2.1			
	8.0	6.4	14.7	600	31.4	1.89	25.0	118.5	4.87	3.9	600	22.8	16.1	0.70	1.54	28.0	14.8	1.8			
800				32.5	1.87	26.1	107.6	5.11	3.6	800	23.7	17.8	0.75	1.59	29.1	14.9	2.0				
90	4.0	1.9	4.3	600	30.9	1.86	24.6	117.7	4.87	3.9	600	21.0	15.3	0.73	1.78	27.0	11.8	2.5			
				800	32.0	1.83	25.8	107.0	5.12	3.7	800	21.7	17.0	0.78	1.82	27.9	11.9	2.7			
	6.0	3.7	8.6	600	32.8	1.94	26.2	120.7	4.95	4.1	600	21.6	15.5	0.72	1.73	27.5	12.5	2.4			
				800	34.0	1.91	27.5	109.4	5.22	3.8	800	22.4	17.2	0.77	1.77	28.4	12.6	2.6			
	8.0	6.1	14.2	600	33.9	1.97	27.2	122.3	5.04	4.3	600	21.8	15.6	0.72	1.70	27.6	12.8	2.2			
800				35.0	1.92	28.5	110.6	5.34	4.0	800	22.6	17.3	0.77	1.74	28.5	13.0	2.5				
100	4.0	1.8	4.2	Operation not recommended							Operation not recommended										
	6.0	3.6	8.3	600	20.4	15.2	0.75	1.92	26.9	10.6	2.9	800	21.1	16.9	0.80	1.95	27.7	10.8	3.2		
				600	20.6	15.2	0.74	1.88	27.0	10.9	2.7	800	21.3	16.8	0.79	1.91	27.8	11.1	3.0		
	8.0	5.9	13.7	Operation not recommended							Operation not recommended										
110	4.0	1.7	4.0	Operation not recommended							Operation not recommended										
	6.0	3.5	8.0	600	19.2	15.0	0.78	2.11	26.4	9.1	3.7	800	19.8	16.6	0.84	2.12	27.0	9.3	4.0		
				600	19.4	14.8	0.76	2.07	26.5	9.4	3.4	800	20.0	16.3	0.82	2.09	27.1	9.5	3.8		
	8.0	5.7	13.2	Operation not recommended							Operation not recommended										
Operation not recommended							Operation not recommended														
120	4.0	1.7	3.8	Operation not recommended							Operation not recommended										
	6.0	3.3	7.7	600	17.4	14.4	0.83	2.31	25.3	7.5	4.3	800	17.7	15.7	0.88	2.37	25.8	7.5	4.7		
				600	17.5	14.4	0.82	2.23	25.2	7.9	4.0	800	17.9	15.7	0.87	2.31	25.8	7.8	4.4		
	8.0	5.5	12.7	Operation not recommended							Operation not recommended										
Operation not recommended							Operation not recommended														

Performance capacities shown in thousands of Mbtu/h.

7/18/14

Performance Data cont.

024 - Part Load Dual Capacity with 5-Speed ECM (600 cfm)

EWT °F	Flow gpm	WPD		HEATING - EAT 70°F							COOLING - EAT 80/67 °F							
		PSI	FT	Airflow cfm	HC Mbtu/h	Power kW	HE Mbtu/h	LAT °F	COP	HWC Mbtu/h	Airflow cfm	TC Mbtu/h	SC Mbtu/h	S/T Ratio	Power kW	HR Mbtu/h	EER	HWC Mbtu/h
20	3.0	1.5	3.5	Operation not recommended							Operation not recommended							
	5.0	3.4	7.8	Operation not recommended							Operation not recommended							
	7.0	6.1	14.1	500	11.6	1.17	7.6	91.4	2.89	1.8	Operation not recommended							
				600	12.0	1.20	7.9	88.6	2.93	1.7	Operation not recommended							
30	3.0	1.5	3.4	Operation not recommended							Operation not recommended							
	5.0	3.3	7.6	500	12.7	1.16	8.8	93.6	3.22	1.7	500	17.7	12.6	0.71	0.64	19.9	27.7	-
				600	13.3	1.19	9.2	90.5	3.27	1.6	600	18.0	13.7	0.76	0.67	20.3	26.7	-
	7.0	5.9	13.7	500	13.6	1.19	9.5	95.1	3.35	1.8	500	17.8	12.6	0.71	0.62	19.9	28.7	-
				600	14.1	1.22	10.0	91.8	3.40	1.7	600	18.2	13.7	0.75	0.65	20.5	28.0	-
	40	3.0	1.4	3.3	Operation not recommended							Operation not recommended						
5.0		3.2	7.4	500	14.8	1.18	10.8	97.4	3.68	1.7	500	18.0	12.7	0.71	0.71	20.4	25.3	-
				600	15.3	1.20	11.2	93.7	3.73	1.6	600	18.3	13.9	0.76	0.75	20.9	24.5	-
7.0		5.7	13.2	500	15.6	1.21	11.5	98.9	3.78	1.8	500	18.1	12.7	0.70	0.69	20.5	26.2	-
				600	16.1	1.23	11.9	94.9	3.84	1.7	600	18.5	13.9	0.75	0.72	21.0	25.7	-
50		3.0	1.4	3.2	500	16.3	1.20	12.2	100.2	3.97	1.8	500	17.8	12.3	0.69	0.80	20.6	22.2
	600				16.8	1.22	12.6	95.9	4.04	1.7	600	18.3	13.6	0.74	0.82	21.1	22.4	0.6
	5.0	3.1	7.2	500	16.9	1.20	12.8	101.2	4.11	1.8	500	18.0	12.4	0.69	0.78	20.7	23.0	0.5
				600	17.4	1.22	13.2	96.8	4.18	1.7	600	18.5	13.7	0.74	0.80	21.2	23.2	0.6
	7.0	5.6	12.8	500	17.7	1.23	13.5	102.7	4.20	2.0	500	18.3	12.7	0.69	0.78	21.0	23.6	0.5
				600	18.2	1.25	13.9	98.1	4.28	1.8	600	18.8	14.1	0.75	0.79	21.5	23.7	0.5
60	3.0	1.3	3.1	500	18.3	1.23	14.1	104.0	4.37	2.0	500	17.3	12.0	0.69	0.90	20.4	19.2	0.7
				600	18.8	1.24	14.6	99.0	4.45	1.8	600	17.8	13.3	0.74	0.92	21.0	19.3	0.8
	5.0	3.0	6.9	500	19.1	1.23	14.9	105.3	4.55	2.0	500	17.5	12.1	0.69	0.88	20.5	19.9	0.7
				600	19.5	1.23	15.3	100.1	4.63	1.9	600	18.0	13.3	0.74	0.90	21.0	20.0	0.8
	7.0	5.4	12.4	500	19.7	1.26	15.5	106.5	4.61	2.1	500	17.8	12.4	0.70	0.87	20.8	20.4	0.6
				600	20.2	1.26	15.9	101.1	4.69	1.9	600	18.3	13.7	0.75	0.89	21.3	20.6	0.7
70	3.0	1.3	3.0	500	20.4	1.26	16.1	107.7	4.75	2.2	500	16.8	11.7	0.69	1.00	20.3	16.8	1.0
				600	20.8	1.26	16.5	102.0	4.84	2.0	600	17.3	12.9	0.75	1.02	20.8	16.9	1.1
	5.0	2.9	6.7	500	21.2	1.25	17.0	109.3	4.97	2.2	500	17.0	11.7	0.69	0.98	20.3	17.4	0.9
				600	21.6	1.25	17.4	103.4	5.07	2.0	600	17.5	13.0	0.74	1.00	20.9	17.5	1.0
	7.0	5.2	12.0	500	21.8	1.28	17.4	110.4	4.99	2.3	500	17.3	12.0	0.70	0.97	20.6	17.8	0.9
				600	22.2	1.28	17.8	104.2	5.09	2.1	600	17.8	13.3	0.75	0.99	21.1	18.0	1.0
80	3.0	1.3	2.9	500	22.4	1.28	18.0	111.4	5.11	2.5	500	16.0	11.4	0.71	1.13	19.9	14.2	1.4
				600	22.7	1.28	18.3	105.0	5.21	2.2	600	16.5	12.6	0.76	1.16	20.4	14.3	1.5
	5.0	2.8	6.5	500	23.4	1.28	19.1	113.4	5.39	2.5	500	16.2	11.4	0.71	1.10	20.0	14.7	1.3
				600	23.7	1.27	19.4	106.6	5.49	2.3	600	16.6	12.6	0.76	1.13	20.5	14.8	1.4
	7.0	5.0	11.6	500	23.8	1.30	19.3	114.0	5.35	2.6	500	16.5	11.7	0.71	1.09	20.2	15.0	1.2
				600	24.0	1.29	19.6	107.1	5.46	2.4	600	16.9	13.0	0.77	1.12	20.7	15.2	1.3
90	3.0	1.2	2.8	500	24.4	1.31	19.9	115.1	5.45	2.8	500	15.3	11.0	0.72	1.26	19.6	12.1	1.9
				600	24.6	1.29	20.1	107.9	5.56	2.5	600	15.7	12.2	0.78	1.29	20.1	12.2	2.0
	5.0	2.7	6.2	500	25.6	1.30	21.2	117.4	5.78	2.9	500	15.4	11.1	0.72	1.23	19.6	12.5	1.8
				600	25.8	1.28	21.4	109.8	5.90	2.6	600	15.8	12.3	0.78	1.26	20.1	12.6	1.9
	7.0	4.8	11.2	500	25.7	1.32	21.2	117.6	5.70	2.9	500	15.6	11.4	0.73	1.22	19.8	12.8	1.7
				600	25.8	1.30	21.4	109.9	5.81	2.6	600	16.1	12.6	0.78	1.25	20.3	12.9	1.9
100	3.0	1.2	2.7	Operation not recommended							Operation not recommended							
	5.0	2.6	6.0	500	14.5	10.8	0.75	1.40	19.2	10.3	2.3	Operation not recommended						
				600	14.9	12.0	0.81	1.43	19.7	10.4	2.5	Operation not recommended						
	7.0	4.7	10.8	500	14.7	11.1	0.75	1.39	19.4	10.6	2.1	Operation not recommended						
600				15.1	12.3	0.81	1.41	19.9	10.7	2.4	Operation not recommended							
110	3.0	1.1	2.6	Operation not recommended							Operation not recommended							
	5.0	2.5	5.8	500	13.5	10.5	0.78	1.57	18.9	8.7	3.1	Operation not recommended						
				600	13.9	11.7	0.84	1.60	19.4	8.7	3.3	Operation not recommended						
	7.0	4.5	10.4	500	13.8	10.8	0.78	1.55	19.1	8.9	2.9	Operation not recommended						
600				14.2	12.0	0.85	1.58	19.5	8.9	3.2	Operation not recommended							
120	3.0	1.1	2.5	Operation not recommended							Operation not recommended							
	5.0	2.4	5.6	500	12.6	10.5	0.83	1.77	18.7	7.1	3.7	Operation not recommended						
				600	12.8	11.4	0.89	1.82	19.0	7.0	4.0	Operation not recommended						
	7.0	4.3	10.0	500	12.7	10.5	0.82	1.72	18.6	7.4	3.4	Operation not recommended						
600				13.0	11.4	0.88	1.77	19.0	7.3	3.8	Operation not recommended							

Performance capacities shown in thousands of Mbtu/h.

7/18/14

Performance Data cont.

036 - Full Load Dual Capacity with 5-Speed ECM (1200 cfm)

EWT °F	Flow gpm	WPD		HEATING - EAT 70°F							COOLING - EAT 80/67 °F								
		PSI	FT	Airflow cfm	HC MBtu/h	Power kW	HE MBtu/h	LAT °F	COP	HWC MBtu/h	Airflow cfm	TC MBtu/h	SC MBtu/h	S/T Ratio	Power kW	HR MBtu/h	EER	HWC MBtu/h	
20	5.0	2.0	4.6	Operation not recommended															
	7.0	3.7	8.7	Operation not recommended															
	9.0	6.0	13.8	1000	24.4	2.27	16.6	92.6	3.15	3.3	Operation not recommended								
1200				25.2	2.34	17.2	89.4	3.16	3.0										
30	5.0	1.9	4.5	Operation not recommended															
	7.0	3.6	8.4	1000	27.9	2.32	20.0	95.8	3.53	3.5	1000	34.1	21.8	0.64	1.58	39.5	21.7	-	
				1200	28.7	2.39	20.5	92.1	3.52	3.2	1200	34.7	23.9	0.69	1.66	40.3	20.9	-	
	9.0	5.8	13.4	1000	28.3	2.34	20.3	96.2	3.55	3.6	1000	34.3	21.8	0.64	1.53	39.5	22.4	-	
				1200	29.3	2.41	21.0	92.6	3.55	3.3	1200	35.1	23.9	0.68	1.61	40.6	21.9	-	
40	5.0	1.9	4.3	Operation not recommended															
	7.0	3.5	8.2	1000	31.6	2.43	23.3	99.3	3.81	3.8	1000	36.2	24.0	0.66	1.73	42.1	20.9	-	
				1200	32.6	2.48	24.1	95.2	3.85	3.5	1200	36.9	26.1	0.71	1.81	43.1	20.3	-	
	9.0	5.6	13.0	1000	32.3	2.46	23.9	99.9	3.85	3.9	1000	36.5	24.0	0.66	1.68	42.2	21.7	-	
				1200	33.3	2.51	24.7	95.7	3.89	3.6	1200	37.3	26.1	0.70	1.75	43.3	21.3	-	
50	5.0	1.8	4.2	1000	34.1	2.49	25.7	101.6	4.02	4.1	1000	36.3	23.7	0.65	1.97	43.1	18.4	1.8	
				1200	35.2	2.52	26.6	97.1	4.08	3.8	1200	38.2	26.3	0.69	2.08	45.3	18.4	1.9	
	7.0	3.4	7.9	1000	35.4	2.55	26.7	102.8	4.07	4.2	1000	37.1	24.0	0.65	1.86	43.5	20.0	1.7	
				1200	36.5	2.58	27.7	98.2	4.15	3.9	1200	39.0	26.6	0.68	1.95	45.7	20.0	1.8	
	9.0	5.4	12.6	1000	36.2	2.57	27.4	103.5	4.13	4.4	1000	37.5	25.6	0.68	1.81	43.7	20.7	1.6	
1200				37.3	2.60	28.4	98.8	4.20	4.0	1200	39.5	28.4	0.72	1.90	46.0	20.7	1.7		
60	5.0	1.8	4.1	1000	37.5	2.59	28.6	104.7	4.24	4.6	1000	35.8	24.1	0.67	2.14	43.1	16.7	2.1	
				1200	38.7	2.61	29.8	99.9	4.35	4.2	1200	37.5	26.8	0.71	2.24	45.2	16.8	2.3	
	7.0	3.3	7.6	1000	39.2	2.67	30.1	106.3	4.31	4.7	1000	36.6	24.4	0.67	2.04	43.6	18.0	2.0	
				1200	40.4	2.68	31.3	101.2	4.42	4.4	1200	38.4	27.0	0.70	2.12	45.6	18.1	2.2	
	9.0	5.3	12.2	1000	40.1	2.69	30.9	107.2	4.36	4.9	1000	37.0	25.7	0.69	1.99	43.8	18.6	1.9	
1200				41.4	2.71	32.2	102.0	4.49	4.5	1200	38.8	28.5	0.73	2.08	45.9	18.7	2.1		
70	5.0	1.7	3.9	1000	40.9	2.70	31.7	107.8	4.44	5.1	1000	35.2	24.5	0.69	2.32	43.1	15.2	2.6	
				1200	42.3	2.70	33.1	102.6	4.60	4.7	1200	36.8	27.2	0.74	2.40	45.0	15.3	2.8	
	7.0	3.2	7.4	1000	43.0	2.78	33.5	109.8	4.52	5.3	1000	36.1	24.8	0.69	2.22	43.7	16.3	2.4	
				1200	44.4	2.78	34.9	104.2	4.67	4.9	1200	37.7	27.4	0.73	2.29	45.5	16.4	2.7	
	9.0	5.1	11.8	1000	44.1	2.82	34.5	110.8	4.58	5.4	1000	36.5	25.7	0.71	2.16	43.9	16.9	2.3	
1200				45.6	2.81	36.0	105.2	4.76	5.0	1200	38.1	28.5	0.75	2.25	45.8	17.0	2.5		
80	5.0	1.6	3.8	1000	44.1	2.82	34.5	110.8	4.59	5.8	1000	33.7	24.3	0.72	2.53	42.3	13.3	3.2	
				1200	45.7	2.80	36.1	105.2	4.79	5.4	1200	35.1	27.1	0.77	2.60	43.9	13.5	3.4	
	7.0	3.1	7.1	1000	46.7	2.93	36.7	113.2	4.67	6.0	1000	34.6	24.6	0.71	2.44	43.0	14.2	3.0	
				1200	48.2	2.90	38.3	107.2	4.87	5.6	1200	36.0	27.3	0.76	2.51	44.6	14.4	3.3	
	9.0	4.9	11.4	1000	48.0	2.97	37.9	114.4	4.74	6.2	1000	35.0	25.3	0.72	2.39	43.2	14.7	2.8	
1200				49.6	2.92	39.7	108.3	4.98	5.7	1200	36.5	28.0	0.77	2.46	44.8	14.8	3.1		
90	5.0	1.6	3.7	1000	47.4	2.94	37.3	113.9	4.72	6.6	1000	32.2	24.2	0.75	2.74	41.5	11.8	4.1	
				1200	49.0	2.90	39.2	107.8	4.96	6.1	1200	33.3	26.9	0.81	2.81	42.9	11.9	4.3	
	7.0	3.0	6.9	1000	50.3	3.07	39.9	116.6	4.80	6.8	1000	33.2	24.6	0.74	2.66	42.2	12.5	3.8	
				1200	52.1	3.02	41.8	110.2	5.06	6.3	1200	34.4	27.2	0.79	2.73	43.7	12.6	4.1	
	9.0	4.8	11.0	1000	51.9	3.12	41.3	118.1	4.88	7.0	1000	33.5	24.8	0.74	2.62	42.5	12.8	3.5	
1200				53.7	3.04	43.3	111.4	5.18	6.5	1200	34.8	27.4	0.79	2.67	43.9	13.0	3.9		
100	5.0	1.5	3.5	Operation not recommended															
	7.0	2.9	6.6	1000	31.2	2.40	24.0	97.7	2.95	41.3	10.6	4.6	Operation not recommended						
				1200	32.3	2.67	26.7	98.3	3.00	42.5	10.8	5.0							
	9.0	4.6	10.6	1000	31.6	2.40	24.0	97.6	2.90	41.5	10.9	4.3	Operation not recommended						
1200				32.6	2.65	26.5	98.5	2.95	42.7	11.1	4.7								
110	5.0	1.5	3.4	Operation not recommended															
	7.0	2.8	6.4	1000	29.4	2.35	23.5	98.0	3.25	40.4	9.0	5.8	Operation not recommended						
				1200	30.2	2.61	26.1	98.7	3.27	41.3	9.2	6.2							
	9.0	4.4	10.2	1000	29.7	2.32	23.2	97.8	3.19	40.5	9.3	5.4	Operation not recommended						
1200				30.5	2.56	25.6	98.4	3.22	41.5	9.4	5.9								
120	5.0	1.4	3.3	Operation not recommended															
	7.0	2.7	6.1	1000	27.3	2.26	22.6	98.3	3.57	39.5	7.6	6.9	Operation not recommended						
				1200	27.8	2.45	24.5	98.8	3.67	40.3	7.6	7.4							
	9.0	4.2	9.8	1000	27.5	2.26	22.6	98.2	3.46	39.3	8.0	6.4	Operation not recommended						
1200				28.1	2.45	24.5	98.7	3.57	40.3	7.9	7.1								

Performance capacities shown in thousands of Mbtu/h.

7/18/14

Performance Data cont.

036 - Part Load Dual Capacity with 5-Speed ECM (1000 cfm)

EWT °F	Flow gpm	WPD		HEATING - EAT 70°F							COOLING - EAT 80/67 °F										
		PSI	FT	Airflow cfm	HC Mbtu/h	Power kW	HE Mbtu/h	LAT °F	COP	HWC Mbtu/h	Airflow cfm	TC Mbtu/h	SC Mbtu/h	S/T Ratio	Power kW	HR Mbtu/h	EER	HWC Mbtu/h			
20	4.0	1.4	3.2	Operation not recommended										Operation not recommended							
	6.0	2.8	6.5	Operation not recommended										Operation not recommended							
	8.0	4.8	11.1	850	17.1	1.74	11.1	88.6	2.87	2.9	Operation not recommended										
				1000	17.8	1.79	11.7	86.5	2.91	2.6	Operation not recommended										
30	4.0	1.4	3.2	Operation not recommended										Operation not recommended							
	6.0	2.7	6.3	850	18.6	1.72	12.8	90.3	3.17	2.8	850	25.8	16.5	0.64	0.96	29.1	26.8	-			
				1000	19.4	1.77	13.4	88.0	3.22	2.5	1000	26.2	18.1	0.69	1.01	29.7	25.8	-			
	8.0	4.7	10.8	850	19.8	1.76	13.8	91.6	3.29	2.9	850	25.9	16.5	0.64	0.93	29.1	27.7	-			
				1000	20.7	1.81	14.5	89.1	3.34	2.6	1000	26.6	18.1	0.68	0.98	29.9	27.1	-			
	40	4.0	1.3	3.1	Operation not recommended										Operation not recommended						
6.0		2.6	6.1	850	21.8	1.75	15.8	93.7	3.64	2.8	850	27.7	18.9	0.68	1.06	31.4	26.1	-			
				1000	22.6	1.79	16.5	90.9	3.70	2.6	1000	28.3	20.6	0.73	1.11	32.1	25.4	-			
8.0		4.5	10.4	850	23.0	1.80	16.8	95.0	3.75	2.9	850	28.0	18.9	0.68	1.03	31.5	27.1	-			
				1000	23.8	1.83	17.5	92.0	3.80	2.7	1000	28.6	20.6	0.72	1.08	32.3	26.5	-			
50		4.0	1.3	3.0	850	24.1	1.79	18.0	96.2	3.95	3.0	850	29.0	20.3	0.70	1.19	33.1	24.3	0.9		
	1000				24.8	1.81	18.7	93.0	4.02	2.7	1000	29.8	22.4	0.75	1.22	34.0	24.5	1.0			
	6.0	2.6	5.9	850	24.9	1.79	18.8	97.2	4.09	3.0	850	29.3	20.4	0.70	1.16	33.3	25.2	0.9			
				1000	25.7	1.81	19.5	93.8	4.16	2.8	1000	30.1	22.6	0.75	1.19	34.2	25.4	0.9			
	8.0	4.4	10.1	850	26.1	1.83	19.9	98.4	4.18	3.1	850	29.8	20.9	0.70	1.15	33.7	25.8	0.8			
				1000	26.9	1.85	20.6	94.9	4.26	2.9	1000	30.6	23.1	0.76	1.18	34.6	26.0	0.9			
60	4.0	1.2	2.9	850	27.3	1.83	21.1	99.7	4.38	3.2	850	28.0	19.8	0.71	1.34	32.6	20.9	1.3			
				1000	28.0	1.84	21.7	95.9	4.46	3.0	1000	28.8	21.9	0.76	1.37	33.4	21.0	1.4			
	6.0	2.5	5.7	850	28.4	1.82	22.2	100.9	4.57	3.3	850	28.2	19.9	0.71	1.31	32.7	21.6	1.2			
				1000	29.1	1.83	22.8	96.9	4.65	3.1	1000	29.0	22.0	0.76	1.33	33.6	21.8	1.3			
	8.0	4.2	9.8	850	29.4	1.86	23.0	102.0	4.62	3.4	850	28.7	20.4	0.71	1.30	33.1	22.2	1.1			
				1000	30.0	1.87	23.7	97.8	4.70	3.2	1000	29.5	22.6	0.77	1.32	34.0	22.3	1.2			
70	4.0	1.2	2.8	850	30.5	1.87	24.1	103.2	4.79	3.6	850	26.9	19.3	0.72	1.49	32.0	18.1	1.7			
				1000	31.1	1.87	24.7	98.8	4.88	3.3	1000	27.7	21.4	0.77	1.52	32.9	18.2	1.8			
	6.0	2.4	5.5	850	31.8	1.86	25.5	104.7	5.02	3.7	850	27.2	19.4	0.72	1.45	32.1	18.7	1.6			
				1000	32.4	1.86	26.1	100.0	5.11	3.4	1000	27.9	21.5	0.77	1.48	33.0	18.9	1.7			
	8.0	4.1	9.5	850	32.7	1.90	26.2	105.6	5.04	3.8	850	27.6	19.9	0.72	1.44	32.5	19.2	1.5			
				1000	33.2	1.90	26.8	100.8	5.14	3.5	1000	28.4	22.1	0.78	1.47	33.4	19.4	1.7			
80	4.0	1.2	2.7	850	34.0	1.91	27.4	107.0	5.21	4.1	850	25.7	19.1	0.74	1.69	31.5	15.2	2.3			
				1000	34.4	1.90	27.9	101.9	5.31	3.8	1000	26.4	21.1	0.80	1.72	32.3	15.4	2.5			
	6.0	2.3	5.4	850	35.6	1.90	29.1	108.8	5.49	4.3	850	25.9	19.2	0.74	1.64	31.5	15.8	2.2			
				1000	36.0	1.89	29.6	103.3	5.60	3.9	1000	26.7	21.3	0.80	1.68	32.4	15.9	2.4			
	8.0	4.0	9.2	850	36.1	1.94	29.5	109.3	5.46	4.4	850	26.4	19.7	0.75	1.63	31.9	16.2	2.0			
				1000	36.5	1.92	29.9	103.8	5.56	4.1	1000	27.1	21.8	0.80	1.66	32.8	16.3	2.2			
90	4.0	1.1	2.6	850	37.4	1.96	30.8	110.8	5.60	4.7	850	24.5	18.9	0.77	1.89	30.9	13.0	3.2			
				1000	37.7	1.93	31.1	104.9	5.72	4.4	1000	25.2	20.9	0.83	1.92	31.7	13.1	3.4			
	6.0	2.2	5.2	850	39.4	1.94	32.7	112.9	5.94	4.9	850	24.7	19.0	0.77	1.84	31.0	13.4	3.0			
				1000	39.6	1.91	33.1	106.7	6.07	4.5	1000	25.4	21.0	0.83	1.87	31.8	13.6	3.2			
	8.0	3.8	8.8	850	39.5	1.98	32.8	113.1	5.85	5.0	850	25.1	19.5	0.78	1.82	31.3	13.8	2.8			
				1000	39.7	1.95	33.1	106.8	5.98	4.7	1000	25.8	21.5	0.83	1.86	32.1	13.9	3.1			
100	4.0	1.1	2.5	Operation not recommended										Operation not recommended							
	6.0	2.2	5.0	850	23.0	18.4	0.80	2.08	30.1	11.1	3.8	Operation not recommended									
				1000	23.7	20.3	0.86	2.12	30.9	11.2	4.1	Operation not recommended									
	8.0	3.7	8.5	850	23.4	18.8	0.80	2.06	30.5	11.4	3.5	Operation not recommended									
1000				24.1	20.9	0.87	2.10	31.2	11.5	3.9	Operation not recommended										
110	4.0	1.0	2.4	Operation not recommended										Operation not recommended							
	6.0	2.1	4.8	850	21.4	17.8	0.83	2.32	29.3	9.2	4.9	Operation not recommended									
				1000	22.0	19.7	0.89	2.37	30.1	9.3	5.3	Operation not recommended									
	8.0	3.5	8.2	850	21.7	18.2	0.84	2.30	29.6	9.4	4.6	Operation not recommended									
1000				22.3	20.2	0.90	2.35	30.4	9.5	5.1	Operation not recommended										
120	4.0	1.0	2.3	Operation not recommended										Operation not recommended							
	6.0	2.0	4.6	850	19.8	17.9	0.90	2.63	28.8	7.5	6.0	Operation not recommended									
				1000	20.1	19.4	0.96	2.70	29.4	7.5	6.4	Operation not recommended									
	8.0	3.4	7.9	850	20.0	17.9	0.90	2.55	28.7	7.8	5.5	Operation not recommended									
1000				20.4	19.4	0.95	2.63	29.3	7.8	6.1	Operation not recommended										

Performance capacities shown in thousands of Mbtu/h.

7/18/14

Performance Data cont.

048 - Full Load Dual Capacity with 5-Speed ECM High Speed (1700 cfm)

EWT °F	Flow gpm	WPD		HEATING - EAT 70°F							COOLING - EAT 80/67 °F							
		PSI	FT	Airflow cfm	HC kBtuh	Power kW	HE kBtuh	LAT °F	COP	HWC kBtuh	Airflow cfm	TC kBtuh	SC kBtuh	S/T Ratio	Power kW	HR kBtuh	EER	HWC kBtuh
20	6.0	1.8	4.1	Operation not recommended							Operation not recommended							
	9.0	4.0	9.2	Operation not recommended							Operation not recommended							
	12.0	7.3	16.8	1400	31.6	2.98	21.4	90.9	3.10	5.6	Operation not recommended							
				1700	32.7	3.03	22.4	87.8	3.17	5.1	Operation not recommended							
30	6.0	1.7	3.9	Operation not recommended							Operation not recommended							
	9.0	3.9	8.9	1400	35.0	3.02	24.7	93.1	3.39	5.7	1400	47.5	30.0	0.63	2.08	54.6	22.8	-
				1700	36.1	3.04	25.7	89.6	3.47	5.3	1700	48.3	32.7	0.68	2.19	55.8	22.0	-
	12.0	7.0	16.3	1400	35.8	3.04	25.5	93.7	3.45	6.0	1400	47.7	30.0	0.63	2.02	54.6	23.6	-
				1700	37.1	3.08	26.6	90.2	3.53	5.4	1700	48.9	32.7	0.67	2.12	56.1	23.1	-
40	6.0	1.7	3.8	Operation not recommended							Operation not recommended							
	9.0	3.7	8.7	1400	39.5	3.13	28.9	96.1	3.71	6.3	1400	50.0	32.6	0.65	2.28	57.8	22.0	-
				1700	40.9	3.13	30.3	92.3	3.84	5.8	1700	51.0	35.6	0.70	2.39	59.1	21.3	-
	12.0	6.8	15.8	1400	40.8	3.15	30.1	97.0	3.80	6.6	1400	50.4	32.6	0.65	2.21	58.0	22.8	-
				1700	42.2	3.17	31.4	93.0	3.91	6.0	1700	51.6	35.6	0.69	2.31	59.4	22.3	-
50	6.0	1.6	3.7	1400	40.9	3.13	30.3	97.1	3.83	6.6	1400	51.2	32.5	0.64	2.92	61.1	17.5	3.0
				1700	42.2	3.13	31.6	93.0	3.96	6.1	1700	52.8	38.4	0.73	3.04	63.2	17.3	3.1
	9.0	3.6	8.4	1400	44.1	3.23	33.1	99.2	4.00	7.0	1400	52.3	32.7	0.63	2.53	60.9	20.7	2.8
				1700	45.8	3.21	34.9	95.0	4.18	6.5	1700	53.9	38.5	0.72	2.65	62.9	20.3	3.0
	12.0	6.6	15.3	1400	45.8	3.25	34.7	100.3	4.13	7.4	1400	52.6	32.7	0.62	2.38	60.7	22.1	2.6
			1700	47.3	3.25	36.2	95.8	4.26	6.7	1700	54.2	38.5	0.71	2.50	62.7	21.7	2.9	
60	6.0	1.6	3.6	1400	44.9	3.27	33.7	99.7	4.02	7.4	1400	50.5	32.6	0.64	3.10	61.1	16.3	3.7
				1700	46.5	3.25	35.4	95.3	4.19	6.9	1700	52.1	38.4	0.74	3.24	63.1	16.1	3.8
	9.0	3.5	8.1	1400	48.5	3.35	37.1	102.1	4.25	7.9	1400	51.4	32.8	0.64	2.75	60.7	18.7	3.4
				1700	50.4	3.31	39.1	97.5	4.47	7.3	1700	52.9	38.6	0.73	2.88	62.8	18.4	3.6
	12.0	6.4	14.8	1400	50.6	3.38	39.1	103.5	4.39	8.3	1400	51.9	32.9	0.63	2.61	60.8	19.9	3.2
			1700	52.4	3.34	41.0	98.5	4.60	7.6	1700	53.5	38.7	0.72	2.73	62.8	19.6	3.5	
70	6.0	1.5	3.5	1400	48.8	3.41	37.2	102.3	4.20	8.4	1400	49.9	32.6	0.65	3.28	61.1	15.2	4.6
				1700	50.7	3.37	39.2	97.6	4.41	7.8	1700	51.4	38.3	0.75	3.44	63.2	15.0	4.8
	9.0	3.4	7.9	1400	53.0	3.47	41.1	105.0	4.48	8.9	1400	50.4	32.9	0.65	2.97	60.5	16.9	4.2
				1700	55.1	3.41	43.4	100.0	4.73	8.3	1700	52.0	38.7	0.74	3.11	62.6	16.7	4.5
	12.0	6.2	14.3	1400	55.4	3.51	43.4	106.6	4.63	9.4	1400	51.3	33.1	0.65	2.84	61.0	18.0	3.9
			1700	57.5	3.43	45.8	101.3	4.91	8.7	1700	52.8	38.9	0.74	2.95	62.9	17.9	4.3	
80	6.0	1.4	3.3	1400	52.7	3.56	40.5	104.8	4.33	9.6	1400	47.9	32.0	0.67	3.50	59.8	13.7	5.8
				1700	54.7	3.50	42.8	99.8	4.58	8.9	1700	49.4	37.6	0.76	3.65	61.9	13.5	6.1
	9.0	3.3	7.6	1400	57.2	3.60	44.9	107.8	4.65	10.2	1400	48.2	32.4	0.67	3.25	59.3	14.8	5.3
				1700	59.5	3.51	47.5	102.4	4.97	9.5	1700	49.6	38.1	0.77	3.38	61.1	14.7	5.7
	12.0	6.0	13.8	1400	60.1	3.64	47.7	109.8	4.84	10.7	1400	49.2	32.6	0.66	3.11	59.9	15.8	5.0
			1700	62.5	3.54	50.4	104.1	5.17	9.9	1700	50.8	38.3	0.76	3.24	61.8	15.7	5.5	
90	6.0	1.4	3.2	1400	56.5	3.72	43.9	107.4	4.46	10.9	1400	45.9	31.4	0.68	3.72	58.6	12.3	7.4
				1700	58.7	3.64	46.3	102.0	4.73	10.2	1700	47.4	36.9	0.78	3.87	60.6	12.2	7.8
	9.0	3.2	7.3	1400	61.5	3.74	48.7	110.7	4.82	11.6	1400	45.9	31.8	0.69	3.53	58.0	13.0	6.7
				1700	64.0	3.62	51.7	104.9	5.19	10.8	1700	47.2	37.5	0.79	3.66	59.7	12.9	7.2
	12.0	5.8	13.3	1400	64.9	3.78	52.0	112.9	5.03	12.2	1400	47.2	32.2	0.68	3.38	58.8	14.0	6.3
			1700	67.6	3.66	55.1	106.8	5.41	11.4	1700	48.7	37.8	0.78	3.53	60.7	13.8	7.0	
100	6.0	1.3	3.1	Operation not recommended							Operation not recommended							
	9.0	3.1	7.1	Operation not recommended							Operation not recommended							
	12.0	5.6	12.9	Operation not recommended							1400	43.0	31.3	0.73	3.88	56.2	11.1	8.2
				Operation not recommended							1700	44.3	36.9	0.83	4.03	58.1	11.0	8.8
110	6.0	1.3	3.0	Operation not recommended							Operation not recommended							
	9.0	2.9	6.8	Operation not recommended							Operation not recommended							
	12.0	5.4	12.4	Operation not recommended							1400	40.1	30.8	0.77	4.22	54.5	9.5	10.3
				Operation not recommended							1700	41.4	36.3	0.88	4.40	56.4	9.4	11.3
				Operation not recommended							1400	42.0	31.4	0.75	4.09	56.0	10.3	9.9
			Operation not recommended							1700	43.2	36.8	0.85	4.27	57.7	10.1	11.0	
120	6.0	1.2	2.9	Operation not recommended							Operation not recommended							
	9.0	2.8	6.5	Operation not recommended							Operation not recommended							
	12.0	5.1	11.9	Operation not recommended							1400	38.9	31.9	0.82	4.74	55.1	8.2	13.1
				Operation not recommended							1700	39.6	34.7	0.88	4.87	56.2	8.1	14.1
			Operation not recommended							1400	39.3	31.9	0.81	4.59	54.9	8.6	12.1	
			Operation not recommended							1700	40.1	34.7	0.86	4.74	56.3	8.5	13.4	

Performance capacities shown in thousands of Mbtu/h.

9/25/14

Performance Data cont.

048 - Part Load Dual Capacity with 5-Speed ECM (1250 cfm)

EWT °F	Flow gpm	WPD		HEATING - EAT 70°F							COOLING - EAT 80/67 °F							
		PSI	FT	Airflow cfm	HC Mbtu/h	Power kW	HE Mbtu/h	LAT °F	COP	HWC Mbtu/h	Airflow cfm	TC Mbtu/h	SC Mbtu/h	S/T Ratio	Power kW	HR Mbtu/h	EER	HWC Mbtu/h
20	5.0	1.2	2.7	Operation not recommended							Operation not recommended							
	8.0	3.2	7.3	Operation not recommended							Operation not recommended							
	11.0	6.1	14.1	1000	22.6	2.20	15.1	91.0	3.01	4.4	Operation not recommended							
1250				23.5	2.24	15.8	87.4	3.08	4.0	Operation not recommended								
30	5.0	1.1	2.6	Operation not recommended							Operation not recommended							
	8.0	3.1	7.1	1000	25.6	2.20	18.1	93.7	3.41	4.4	1000	34.9	23.2	0.67	1.07	38.5	32.6	-
				1250	26.4	2.22	18.9	89.6	3.49	4.0	1250	35.4	25.4	0.72	1.13	39.3	31.5	-
	11.0	5.9	13.7	1000	26.3	2.22	18.7	94.3	3.47	4.5	1000	35.1	23.2	0.66	1.04	38.6	33.8	-
				1250	27.2	2.25	19.5	90.2	3.55	4.1	1250	35.9	25.4	0.71	1.09	39.6	33.0	-
40	5.0	1.1	2.5	Operation not recommended							Operation not recommended							
	8.0	3.0	6.9	1000	29.0	2.23	21.4	96.8	3.80	4.6	1000	37.1	25.4	0.68	1.20	41.2	30.9	-
				1250	30.0	2.23	22.4	92.2	3.94	4.2	1250	37.8	27.7	0.73	1.26	42.1	30.0	-
	11.0	5.7	13.2	1000	29.9	2.25	22.3	97.7	3.90	4.7	1000	37.4	25.4	0.68	1.17	41.3	32.1	-
				1250	31.0	2.26	23.2	92.9	4.01	4.3	1250	38.2	27.7	0.73	1.22	42.4	31.3	-
50	5.0	1.1	2.5	1000	30.0	2.19	22.5	97.8	4.01	4.8	1000	38.2	25.4	0.66	1.57	43.6	24.3	1.5
				1250	31.0	2.19	23.5	92.9	4.14	4.5	1250	39.4	29.9	0.76	1.64	45.0	24.0	1.6
	8.0	2.9	6.7	1000	32.3	2.26	24.6	100.0	4.19	5.0	1000	39.1	25.5	0.65	1.36	43.7	28.7	1.4
				1250	33.6	2.25	25.9	94.9	4.37	4.6	1250	40.3	30.1	0.75	1.43	45.1	28.2	1.6
	11.0	5.6	12.8	1000	33.6	2.28	25.8	101.1	4.32	5.1	1000	39.3	25.5	0.65	1.28	43.7	30.6	1.3
				1250	34.7	2.28	26.9	95.7	4.46	4.7	1250	40.5	30.1	0.74	1.35	45.1	30.0	1.5
	60	5.0	1.0	2.4	1000	32.7	2.23	25.0	100.2	4.29	5.3	1000	37.5	25.2	0.67	1.76	43.5	21.3
1250					33.8	2.22	26.3	95.1	4.47	4.9	1250	38.7	29.6	0.77	1.84	45.0	21.0	2.3
8.0		2.8	6.5	1000	35.3	2.29	27.5	102.7	4.53	5.4	1000	38.1	25.3	0.66	1.56	43.5	24.4	2.0
				1250	36.7	2.26	29.0	97.2	4.76	5.0	1250	39.3	29.8	0.76	1.64	44.9	24.0	2.2
11.0		5.4	12.4	1000	36.8	2.31	29.0	104.1	4.68	5.6	1000	38.6	25.4	0.66	1.49	43.6	26.0	1.9
1250	38.2	2.28	30.4	98.3	4.90	5.1	1250	39.8	29.9	0.75	1.55	45.0	25.6	2.1				
70	5.0	1.0	2.3	1000	35.3	2.27	27.6	102.7	4.57	5.8	1000	36.8	24.9	0.68	1.95	43.5	18.9	3.0
				1250	36.7	2.24	29.1	97.2	4.80	5.4	1250	38.0	29.3	0.77	2.04	44.9	18.6	3.1
	8.0	2.7	6.2	1000	38.4	2.31	30.5	105.5	4.87	6.0	1000	37.2	25.2	0.68	1.77	43.2	21.1	2.8
				1250	39.9	2.27	32.1	99.5	5.15	5.6	1250	38.4	29.6	0.77	1.85	44.7	20.8	3.0
	11.0	5.2	12.0	1000	40.1	2.33	32.1	107.1	5.04	6.2	1000	37.8	25.3	0.67	1.69	43.6	22.4	2.6
1250	41.6	2.28	33.8	100.8	5.35	5.7	1250	39.0	29.7	0.76	1.75	45.0	22.2	2.8				
80	5.0	1.0	2.2	1000	38.1	2.31	30.2	105.3	4.84	6.6	1000	35.1	24.4	0.69	2.19	42.6	16.0	4.0
				1250	39.6	2.27	31.9	99.3	5.12	6.1	1250	36.2	28.6	0.79	2.28	44.0	15.9	4.3
	8.0	2.6	6.0	1000	41.4	2.33	33.4	108.3	5.20	6.8	1000	35.3	24.6	0.70	2.03	42.2	17.4	3.7
				1250	43.1	2.27	35.3	101.9	5.55	6.3	1250	36.3	29.0	0.80	2.11	43.6	17.2	4.1
	11.0	5.0	11.6	1000	43.5	2.36	35.4	110.3	5.40	7.0	1000	36.1	24.8	0.69	1.94	42.7	18.6	3.5
1250	45.2	2.29	37.4	103.5	5.78	6.5	1250	37.2	29.2	0.78	2.03	44.1	18.4	3.9				
90	5.0	0.9	2.2	1000	40.9	2.35	32.9	107.8	5.11	7.5	1000	33.4	23.8	0.71	2.42	41.7	13.8	5.4
				1250	42.5	2.30	34.6	101.5	5.42	7.0	1250	34.5	27.9	0.81	2.52	43.1	13.7	5.7
	8.0	2.5	5.8	1000	44.4	2.36	36.4	111.1	5.52	7.8	1000	33.4	24.1	0.72	2.30	41.2	14.5	5.0
				1250	46.3	2.28	38.5	104.3	5.94	7.2	1250	34.3	28.3	0.83	2.38	42.5	14.4	5.5
	11.0	4.8	11.2	1000	46.9	2.38	38.8	113.4	5.76	8.0	1000	34.3	24.3	0.71	2.20	41.8	15.6	4.7
1250	48.9	2.31	41.0	106.2	6.20	7.4	1250	35.4	28.6	0.81	2.30	43.2	15.4	5.2				
100	5.0	0.9	2.1	Operation not recommended							Operation not recommended							
	8.0	2.4	5.6	Operation not recommended							1000	31.3	23.3	0.74	2.64	40.3	11.8	6.4
				1250	32.2	27.4	0.85	2.74	41.6	11.8	7.0							
	11.0	4.7	10.8	Operation not recommended							1000	32.4	23.6	0.73	2.54	41.1	12.8	6.0
1250				33.4	27.7	0.83	2.65	42.4	12.6	6.6								
110	5.0	0.9	2.0	Operation not recommended							Operation not recommended							
	8.0	2.3	5.4	Operation not recommended							1000	29.1	22.4	0.77	2.98	39.3	9.8	8.5
				1250	30.1	26.4	0.88	3.10	40.7	9.7	9.2							
	11.0	4.5	10.4	Operation not recommended							1000	30.5	22.9	0.75	2.89	40.4	10.6	7.9
1250				31.4	26.8	0.85	3.01	41.7	10.4	8.7								
120	5.0	0.8	1.9	Operation not recommended							Operation not recommended							
	8.0	2.2	5.2	Operation not recommended							1000	28.2	24.0	0.85	3.40	39.7	8.3	11.0
				1250	28.7	26.1	0.91	3.49	40.6	8.2	11.7							
	11.0	4.3	10.0	Operation not recommended							1000	28.4	24.0	0.85	3.29	39.6	8.6	9.7
1250				29.0	26.1	0.90	3.39	40.6	8.6	10.8								

Performance capacities shown in thousands of Mbtu/h.

7/18/14

Performance Data cont.

060 - Full Load Dual Capacity with 5-Speed ECM (1800 cfm)

EWT °F	Flow gpm	WPD		HEATING - EAT 70°F							COOLING - EAT 80/67 °F							
		PSI	FT	Airflow cfm	HC Mbtu/h	Power kW	HE Mbtu/h	LAT °F	COP	HWC Mbtu/h	Airflow cfm	TC Mbtu/h	SC Mbtu/h	S/T Ratio	Power kW	HR Mbtu/h	EER	HWC Mbtu/h
20	8.0	2.9	6.8	Operation not recommended							Operation not recommended							
	12.0	6.0	13.8	Operation not recommended							Operation not recommended							
	16.0	10.1	23.3	1500	38.6	3.93	25.2	93.8	2.88	6.1	1800	39.6	4.11	25.5	90.3	2.82	5.5	
30	8.0	2.8	6.6	Operation not recommended							Operation not recommended							
	12.0	5.8	13.4	1500	43.9	3.97	30.3	97.1	3.24	6.4	1500	52.9	32.2	0.61	2.69	62.1	19.6	-
				1800	45.1	4.23	30.7	93.2	3.13	5.8	1800	53.7	35.2	0.65	2.84	63.4	18.9	-
	16.0	9.8	22.6	1500	44.5	4.07	30.6	97.5	3.20	6.5	1500	53.2	32.2	0.61	2.61	62.1	20.3	-
1800				45.6	4.27	31.0	93.5	3.13	5.9	1800	54.4	35.2	0.65	2.74	63.8	19.9	-	
40	8.0	2.8	6.4	Operation not recommended							Operation not recommended							
	12.0	5.6	13.0	1500	50.3	4.17	36.1	101.1	3.53	7.0	1500	56.9	35.4	0.62	2.95	67.0	19.3	-
				1800	51.5	4.35	36.6	96.5	3.47	6.4	1800	58.0	38.6	0.67	3.09	68.5	18.8	-
	16.0	9.5	21.9	1500	51.1	4.25	36.6	101.5	3.53	7.2	1500	57.4	35.4	0.62	2.86	67.1	20.1	-
1800				52.3	4.39	37.3	96.9	3.48	6.6	1800	58.7	38.6	0.66	2.99	68.9	19.6	-	
50	8.0	2.7	6.2	1500	53.6	4.28	39.0	103.1	3.67	7.5	1500	60.4	38.0	0.63	3.16	71.2	19.1	3.6
				1800	54.8	4.42	39.7	98.2	3.63	7.0	1800	61.6	41.3	0.67	3.37	73.1	18.3	3.8
	12.0	5.4	12.6	1500	56.7	4.37	41.8	105.0	3.81	7.8	1500	61.0	38.3	0.63	3.10	71.6	19.7	3.3
				1800	57.9	4.48	42.6	99.8	3.79	7.2	1800	62.3	41.7	0.67	3.29	73.5	18.9	3.6
	16.0	9.2	21.2	1500	57.7	4.42	42.6	105.6	3.83	8.0	1500	61.6	38.7	0.63	3.05	72.0	20.2	3.1
				1800	58.9	4.52	43.5	100.3	3.82	7.3	1800	62.9	42.1	0.67	3.24	73.9	19.4	3.4
60	8.0	2.6	6.0	1500	60.1	4.51	44.7	107.1	3.91	8.5	1500	59.7	38.5	0.65	3.44	71.4	17.4	4.4
				1800	61.4	4.58	45.8	101.6	3.93	7.8	1800	61.2	41.9	0.68	3.66	73.7	16.7	4.6
	12.0	5.3	12.2	1500	62.9	4.58	47.2	108.8	4.02	8.7	1500	60.3	38.9	0.64	3.37	71.8	17.9	4.1
				1800	64.2	4.64	48.4	103.0	4.06	8.0	1800	61.9	42.3	0.68	3.58	74.1	17.3	4.4
	16.0	8.9	20.6	1500	64.2	4.63	48.4	109.6	4.06	9.0	1500	60.9	39.3	0.65	3.31	72.2	18.4	3.8
				1800	65.7	4.69	49.7	103.8	4.11	8.2	1800	62.5	42.7	0.68	3.52	74.5	17.7	4.2
70	8.0	2.5	5.8	1500	66.6	4.72	50.4	111.1	4.13	9.5	1500	59.0	39.1	0.66	3.71	71.6	15.9	5.4
				1800	68.0	4.74	51.8	105.0	4.20	8.8	1800	60.8	42.5	0.70	3.95	74.3	15.4	5.7
	12.0	5.1	11.8	1500	69.0	4.79	52.6	112.6	4.22	9.8	1500	59.5	39.5	0.66	3.64	72.0	16.4	5.0
				1800	70.6	4.80	54.2	106.3	4.31	9.0	1800	61.5	42.9	0.70	3.87	74.7	15.9	5.4
	16.0	8.6	19.9	1500	70.7	4.85	54.2	113.7	4.28	10.1	1500	60.1	39.8	0.66	3.58	72.3	16.8	4.7
				1800	72.4	4.85	55.9	107.2	4.38	9.3	1800	62.0	43.3	0.70	3.81	75.0	16.3	5.2
80	8.0	2.4	5.6	1500	72.9	4.97	55.9	115.0	4.30	10.6	1500	56.9	38.8	0.68	4.03	70.6	14.1	7.0
				1800	74.6	4.94	57.7	108.4	4.42	9.8	1800	59.0	42.1	0.71	4.29	73.6	13.7	7.4
	12.0	4.9	11.4	1500	74.6	5.03	57.5	116.1	4.35	11.0	1500	57.5	39.1	0.68	3.95	70.9	14.5	6.5
				1800	76.4	4.98	59.4	109.3	4.50	10.1	1800	59.6	42.5	0.71	4.20	73.9	14.2	7.0
	16.0	8.3	19.2	1500	76.9	5.09	59.5	117.5	4.43	11.3	1500	58.0	39.5	0.68	3.88	71.3	14.9	6.0
				1800	78.8	5.03	61.6	110.5	4.59	10.4	1800	60.2	42.9	0.71	4.13	74.3	14.6	6.7
90	8.0	2.3	5.4	1500	79.2	5.21	61.4	118.9	4.46	11.9	1500	54.7	38.4	0.70	4.35	69.5	12.6	9.1
				1800	81.1	5.13	63.6	111.7	4.63	11.0	1800	57.1	41.7	0.73	4.63	72.9	12.3	9.7
	12.0	4.8	11.0	1500	80.3	5.27	62.3	119.5	4.47	12.3	1500	55.3	38.7	0.70	4.26	69.9	13.0	8.5
				1800	82.3	5.16	64.7	112.3	4.68	11.4	1800	57.7	42.1	0.73	4.54	73.1	12.7	9.2
	16.0	8.0	18.5	1500	83.0	5.33	64.8	121.2	4.56	12.6	1500	55.9	39.2	0.70	4.19	70.2	13.3	7.9
				1800	85.2	5.21	67.4	113.8	4.79	11.7	1800	58.3	42.5	0.73	4.46	73.5	13.1	8.8
100	8.0	2.2	5.2	Operation not recommended							Operation not recommended							
	12.0	4.6	10.6	1500	51.7	37.3	0.72	4.70	67.8	11.0	10.2							
				1800	54.2	40.5	0.75	5.00	71.3	10.8	11.0							
	16.0	7.7	17.8	1500	52.2	37.7	0.72	4.61	68.0	11.3	9.5							
1800				54.7	40.9	0.75	4.92	71.5	11.1	10.5								
110	8.0	2.2	5.0	Operation not recommended							Operation not recommended							
	12.0	4.4	10.2	1500	48.1	35.8	0.74	5.13	65.6	9.4	13.1							
				1800	50.7	38.9	0.77	5.47	69.4	9.3	14.2							
	16.0	7.4	17.2	1500	48.6	36.2	0.75	5.04	65.8	9.6	12.2							
1800				51.2	39.3	0.77	5.38	69.5	9.5	13.5								
120	8.0	2.1	4.8	Operation not recommended							Operation not recommended							
	12.0	4.2	9.8	1500	46.1	35.1	0.76	5.96	66.4	7.7	15.6							
				1800	47.0	38.2	0.81	6.11	67.8	7.7	16.3							
	16.0	7.1	16.5	1500	46.5	35.1	0.76	5.76	66.2	8.1	14.5							
1800				47.5	38.2	0.80	5.94	67.8	8.0	15.6								

Performance capacities shown in thousands of Mbtu/h.

7/18/14

Performance Data cont.

060 - Part Load Dual Capacity with 5-Speed ECM (1500 cfm)

EWT °F	Flow gpm	WPD		HEATING - EAT 70°F							COOLING - EAT 80/67 °F							
		PSI	FT	Airflow cfm	HC Mbtu/h	Power kW	HE Mbtu/h	LAT °F	COP	HWC Mbtu/h	Airflow cfm	TC Mbtu/h	SC Mbtu/h	S/T Ratio	Power kW	HR Mbtu/h	EER	HWC Mbtu/h
20	6.0	1.8	4.1	Operation not recommended							Operation not recommended							
	10.0	4.3	10.0	Operation not recommended							Operation not recommended							
	14.0	7.8	18.1	1250	27.7	3.01	17.5	90.5	2.70	5.3	Operation not recommended							
				1500	28.7	3.05	18.3	87.7	2.76	4.8	Operation not recommended							
30	6.0	1.7	3.9	Operation not recommended							Operation not recommended							
	10.0	4.2	9.7	1250	30.9	3.05	20.5	92.9	2.97	5.1	1250	39.9	23.5	0.59	1.57	45.2	25.4	-
				1500	32.0	3.09	21.5	89.8	3.04	4.7	1500	40.5	25.7	0.63	1.65	46.2	24.5	-
	14.0	7.6	17.6	1250	32.0	3.05	21.6	93.7	3.08	5.3	1250	40.1	23.5	0.59	1.52	45.3	26.3	-
				1500	33.1	3.09	22.6	90.4	3.14	4.8	1500	41.1	25.7	0.63	1.60	46.5	25.7	-
	40	6.0	1.7	3.8	Operation not recommended							Operation not recommended						
10.0		4.1	9.4	1250	36.2	3.11	25.6	96.8	3.41	5.4	1250	44.0	27.8	0.63	1.73	49.9	25.5	-
				1500	37.2	3.12	26.6	93.0	3.49	5.0	1500	44.8	30.3	0.68	1.81	51.0	24.8	-
14.0		7.4	17.1	1250	37.4	3.12	26.7	97.7	3.51	5.6	1250	44.4	27.8	0.63	1.67	50.1	26.5	-
	1500			38.4	3.13	27.7	93.7	3.59	5.1	1500	45.4	30.3	0.67	1.75	51.3	25.9	-	
50	6.0	1.6	3.7	1250	40.8	3.12	30.2	100.2	3.84	5.7	1250	48.0	30.5	0.64	1.92	54.5	25.0	1.9
				1500	41.9	3.12	31.3	95.9	3.94	5.3	1500	49.4	34.7	0.70	2.03	56.3	24.4	2.0
	10.0	4.0	9.1	1250	41.5	3.18	30.6	100.7	3.83	5.9	1250	48.1	30.8	0.64	1.85	54.4	26.0	1.7
				1500	42.4	3.16	31.6	96.2	3.94	5.4	1500	49.5	34.9	0.71	1.94	56.1	25.5	1.9
	14.0	7.2	16.5	1250	42.7	3.20	31.8	101.6	3.92	6.0	1250	48.2	30.8	0.64	1.82	54.4	26.6	1.6
				1500	43.7	3.18	32.8	97.0	4.03	5.5	1500	49.6	34.9	0.70	1.90	56.1	26.1	1.8
60	6.0	1.6	3.6	1250	45.2	3.18	34.3	103.5	4.16	6.2	1250	46.4	30.4	0.66	2.16	53.8	21.5	2.6
				1500	46.2	3.16	35.4	98.5	4.29	5.7	1500	47.8	34.4	0.72	2.26	55.6	21.2	2.8
	10.0	3.8	8.8	1250	46.6	3.24	35.6	104.5	4.22	6.4	1250	46.6	30.7	0.66	2.09	53.8	22.3	2.5
				1500	47.3	3.19	36.5	99.2	4.35	5.9	1500	48.0	34.7	0.72	2.18	55.5	22.0	2.7
	14.0	6.9	16.0	1250	47.7	3.27	36.6	105.3	4.28	6.6	1250	46.8	30.8	0.66	2.05	53.8	22.9	2.3
				1500	48.5	3.22	37.5	99.9	4.41	6.1	1500	48.2	34.8	0.72	2.14	55.5	22.5	2.5
70	6.0	1.5	3.5	1250	49.6	3.25	38.5	106.7	4.48	6.9	1250	44.9	30.4	0.68	2.40	53.1	18.7	3.7
				1500	50.4	3.19	39.5	101.1	4.63	6.4	1500	46.3	34.0	0.74	2.50	54.8	18.5	3.9
	10.0	3.7	8.6	1250	51.7	3.30	40.4	108.3	4.59	7.1	1250	45.2	30.6	0.68	2.33	53.1	19.4	3.4
				1500	52.3	3.23	41.2	102.3	4.74	6.5	1500	46.6	34.4	0.74	2.43	54.8	19.2	3.7
	14.0	6.7	15.5	1250	52.7	3.34	41.3	109.0	4.63	7.3	1250	45.4	30.8	0.68	2.28	53.2	19.9	3.2
				1500	53.2	3.27	42.1	102.9	4.78	6.7	1500	46.8	34.6	0.74	2.38	55.0	19.7	3.5
80	6.0	1.4	3.3	1250	53.8	3.29	42.6	109.8	4.79	7.7	1250	42.8	30.0	0.70	2.72	52.0	15.7	5.0
				1500	54.3	3.22	43.3	103.5	4.94	7.1	1500	44.1	33.5	0.76	2.81	53.7	15.7	5.3
	10.0	3.6	8.3	1250	56.8	3.34	45.4	112.1	4.98	7.9	1250	43.1	30.3	0.70	2.65	52.2	16.3	4.7
				1500	57.1	3.25	46.0	105.2	5.16	7.3	1500	44.4	34.0	0.76	2.75	53.8	16.1	5.1
	14.0	6.5	15.0	1250	57.5	3.39	45.9	112.6	4.97	8.1	1250	43.4	30.5	0.70	2.61	52.3	16.6	4.4
				1500	57.7	3.29	46.5	105.6	5.14	7.5	1500	44.8	34.2	0.76	2.70	54.0	16.6	4.8
90	6.0	1.4	3.2	1250	58.0	3.33	46.6	113.0	5.10	8.6	1250	40.6	29.7	0.73	3.04	51.0	13.3	6.9
				1500	58.1	3.25	47.1	105.9	5.25	8.0	1500	41.8	33.0	0.79	3.13	52.5	13.4	7.3
	10.0	3.4	8.0	1250	61.9	3.39	50.4	115.9	5.36	8.9	1250	41.1	30.0	0.73	2.98	51.2	13.8	6.4
				1500	61.9	3.26	50.8	108.2	5.56	8.2	1500	42.3	33.5	0.79	3.08	52.8	13.7	7.0
	14.0	6.2	14.4	1250	62.3	3.44	50.6	116.2	5.31	9.1	1250	41.4	30.3	0.73	2.94	51.4	14.1	6.0
				1500	62.2	3.32	50.9	108.4	5.50	8.5	1500	42.7	33.7	0.79	3.03	53.1	14.1	6.6
100	6.0	1.3	3.1	Operation not recommended							Operation not recommended							
	10.0	3.3	7.7	1250	37.9	29.2	0.77	3.39	49.4	11.2	8.0	Operation not recommended						
				1500	39.0	32.3	0.83	3.48	50.9	11.2	8.7	Operation not recommended						
	14.0	6.0	13.9	1250	38.3	29.6	0.77	3.35	49.7	11.4	7.5	Operation not recommended						
1500				39.5	32.7	0.83	3.43	51.2	11.5	8.3	Operation not recommended							
110	6.0	1.3	3.0	Operation not recommended							Operation not recommended							
	10.0	3.2	7.4	1250	34.7	28.4	0.82	3.81	47.7	9.1	10.4	Operation not recommended						
				1500	35.8	31.2	0.87	3.89	49.0	9.2	11.2	Operation not recommended						
	14.0	5.8	13.4	1250	35.1	28.9	0.82	3.75	47.9	9.4	9.6	Operation not recommended						
1500				36.2	31.7	0.87	3.83	49.3	9.5	10.7	Operation not recommended							
120	6.0	1.2	2.9	Operation not recommended							Operation not recommended							
	10.0	3.1	7.1	1250	34.2	28.0	0.82	4.31	48.9	7.9	13.6	Operation not recommended						
				1500	34.8	30.4	0.87	4.43	49.9	7.9	14.5	Operation not recommended						
	14.0	5.6	12.9	1250	34.5	28.0	0.81	4.17	48.7	8.3	12.5	Operation not recommended						
1500				35.2	30.4	0.86	4.31	49.9	8.2	13.8	Operation not recommended							

Performance capacities shown in thousands of Mbtu/h.

7/18/14

Performance Data cont.

072 - Full Load Dual Capacity with 5-Speed ECM High Speed (2300 cfm)

EWT °F	Flow gpm	WPD		HEATING - EAT 70°F							COOLING - EAT 80/67 °F							
		PSI	FT	Airflow cfm	HC kBtuh	Power kW	HE kBtuh	LAT °F	COP	HWC kBtuh	Airflow cfm	TC kBtuh	SC kBtuh	S/T Ratio	Power kW	HR kBtuh	EER	HWC kBtuh
20	12.0	4.0	9.1	Operation not recommended							Operation not recommended							
	15.0	5.9	13.5	Operation not recommended							Operation not recommended							
	18.0	8.1	18.7	1850	49.3	4.60	33.6	94.7	3.14	8.7	Operation not recommended							
2300				51.1	4.90	34.4	90.6	3.06	7.9	Operation not recommended								
30	12.0	3.8	8.9	Operation not recommended							Operation not recommended							
	15.0	5.7	13.1	1850	55.5	4.74	39.3	97.8	3.43	9.0	1850	57.3	35.2	0.61	3.14	68.0	18.2	-
				2300	57.5	5.04	40.2	93.1	3.34	8.2	2300	58.2	38.5	0.66	3.31	69.5	17.6	-
	18.0	7.8	18.1	1850	56.0	4.78	39.6	98.0	3.43	9.2	1850	57.6	35.2	0.61	3.05	68.0	18.9	-
				2300	58.0	5.09	40.7	93.4	3.34	8.4	2300	59.0	38.5	0.65	3.20	69.9	18.4	-
40	12.0	3.7	8.6	Operation not recommended							Operation not recommended							
	15.0	5.5	12.7	1850	63.0	4.97	46.0	101.5	3.71	9.7	1850	63.0	39.9	0.63	3.47	74.8	18.2	-
				2300	65.1	5.21	47.4	96.2	3.67	8.9	2300	64.2	43.6	0.68	3.64	76.6	17.7	-
	18.0	7.6	17.6	1850	63.9	5.03	46.7	102.0	3.72	10.0	1850	63.5	39.9	0.63	3.36	75.0	18.9	-
				2300	66.1	5.26	48.1	96.6	3.68	9.1	2300	64.9	43.6	0.67	3.52	76.9	18.5	-
50	12.0	3.6	8.3	1850	66.8	5.10	49.3	103.4	3.83	10.4	1850	68.1	43.8	0.64	3.74	80.8	18.2	4.0
				2300	69.0	5.28	51.0	97.8	3.83	9.6	2300	69.5	47.6	0.69	3.98	83.1	17.5	4.3
	15.0	5.3	12.3	1850	70.5	5.20	52.8	105.3	3.97	10.7	1850	68.8	44.3	0.64	3.66	81.3	18.8	3.8
				2300	72.8	5.37	54.5	99.3	3.98	9.9	2300	70.1	48.2	0.69	3.90	83.4	18.0	4.1
	18.0	7.4	17.0	1850	71.8	5.26	53.8	105.9	4.00	11.1	1850	69.5	45.2	0.65	3.60	81.8	19.3	3.5
				2300	74.1	5.42	55.6	99.8	4.01	10.1	2300	70.9	48.6	0.69	3.84	83.9	18.5	3.9
60	12.0	3.5	8.1	1850	74.9	5.40	56.5	107.5	4.07	11.7	1850	69.2	46.3	0.67	4.08	83.1	16.9	5.1
				2300	77.3	5.50	58.5	101.1	4.12	10.8	2300	70.6	50.1	0.71	4.34	85.4	16.3	5.4
	15.0	5.2	11.9	1850	78.2	5.49	59.4	109.1	4.17	12.0	1850	69.9	46.8	0.67	4.00	83.5	17.5	4.7
				2300	80.7	5.58	61.7	102.5	4.24	11.1	2300	71.3	50.6	0.71	4.25	85.8	16.8	5.1
	18.0	7.1	16.5	1850	79.9	5.56	61.0	110.0	4.22	12.4	1850	70.6	47.5	0.67	3.93	84.0	18.0	4.4
				2300	82.6	5.63	63.3	103.2	4.29	11.4	2300	72.0	51.1	0.71	4.19	86.3	17.2	4.9
70	12.0	3.4	7.8	1850	82.9	5.68	63.5	111.5	4.28	13.1	1850	70.3	48.8	0.69	4.43	85.4	15.9	6.5
				2300	85.6	5.72	66.0	104.4	4.38	12.1	2300	71.7	52.5	0.73	4.70	87.8	15.2	6.9
	15.0	5.0	11.6	1850	85.9	5.77	66.2	113.0	4.36	13.5	1850	71.0	49.3	0.69	4.34	85.8	16.4	6.0
				2300	88.6	5.78	68.8	105.7	4.49	12.4	2300	72.4	53.0	0.73	4.60	88.1	15.7	6.5
	18.0	6.9	15.9	1850	88.1	5.85	68.1	114.1	4.42	13.9	1850	71.7	49.8	0.69	4.26	86.3	16.9	5.6
				2300	91.0	5.85	71.0	106.6	4.56	12.8	2300	73.2	53.6	0.73	4.54	88.7	16.1	6.2
80	12.0	3.3	7.5	1850	90.8	6.03	70.3	115.5	4.42	14.8	1850	67.2	47.7	0.71	4.85	83.7	13.8	8.2
				2300	93.8	5.98	73.4	107.8	4.59	13.7	2300	68.5	51.6	0.75	5.16	86.2	13.3	8.7
	15.0	4.8	11.2	1850	93.0	6.11	72.1	116.5	4.46	15.2	1850	67.8	48.2	0.71	4.75	84.0	14.3	7.6
				2300	96.0	6.03	75.4	108.6	4.66	14.1	2300	69.2	52.0	0.75	5.06	86.4	13.7	8.3
	18.0	6.7	15.4	1850	95.8	6.19	74.7	118.0	4.54	15.7	1850	68.5	48.9	0.71	4.67	84.5	14.7	7.1
				2300	99.0	6.09	78.2	109.9	4.76	14.5	2300	69.9	52.6	0.75	4.97	86.9	14.1	7.8
90	12.0	3.1	7.3	1850	98.7	6.37	77.0	119.4	4.54	16.7	1850	64.0	46.6	0.73	5.28	82.0	12.1	10.5
				2300	102.0	6.24	80.7	111.1	4.79	15.4	2300	65.4	50.6	0.77	5.62	84.5	11.6	11.1
	15.0	4.7	10.8	1850	100.1	6.44	78.1	120.1	4.55	17.2	1850	64.6	47.0	0.73	5.17	82.3	12.5	9.8
				2300	103.4	6.27	81.9	111.6	4.83	15.9	2300	66.0	51.0	0.77	5.51	84.8	12.0	10.6
	18.0	6.4	14.9	1850	103.5	6.53	81.3	121.8	4.65	17.7	1850	65.4	48.0	0.73	5.08	82.7	12.9	9.1
				2300	107.0	6.34	85.3	113.1	4.94	16.4	2300	66.7	51.6	0.77	5.41	85.2	12.3	10.1
100	12.0	3.0	7.0	Operation not recommended							Operation not recommended							
	15.0	4.5	10.4	1850	61.3	45.4	0.74	5.73	80.9	10.7	12.0	Operation not recommended						
				2300	62.6	49.1	0.78	6.10	83.4	10.3	13.0	Operation not recommended						
	18.0	6.2	14.3	1850	62.0	46.1	0.74	5.63	81.2	11.0	11.1	Operation not recommended						
2300				63.3	49.5	0.78	5.99	83.7	10.6	12.4	Operation not recommended							
110	12.0	2.9	6.7	Operation not recommended							Operation not recommended							
	15.0	4.3	10.0	1850	58.0	43.8	0.75	6.29	79.5	9.2	15.6	Operation not recommended						
				2300	59.2	47.1	0.79	6.69	82.1	8.9	16.9	Operation not recommended						
	18.0	6.0	13.8	1850	58.7	44.2	0.75	6.18	79.8	9.5	14.4	Operation not recommended						
2300				59.9	47.5	0.79	6.57	82.3	9.1	16.0	Operation not recommended							
120	12.0	2.8	6.5	Operation not recommended							Operation not recommended							
	15.0	4.2	9.6	1850	54.0	42.2	0.78	7.25	78.7	7.4	18.5	Operation not recommended						
				2300	55.0	45.8	0.83	7.44	80.3	7.4	20.0	Operation not recommended						
	18.0	5.7	13.2	1850	54.5	42.2	0.78	7.01	78.4	7.8	17.1	Operation not recommended						
2300				55.6	45.8	0.82	7.24	80.3	7.7	19.0	Operation not recommended							

Performance capacities shown in thousands of Btuh.

7/18/14

Performance Data cont.

072 - Part Load Dual Capacity with 5-Speed ECM (1850 cfm)

EWT °F	Flow gpm	WPD		HEATING - EAT 70°F							COOLING - EAT 80/67 °F							
		PSI	FT	Airflow cfm	HC Mbtu/h	Power kW	HE Mbtu/h	LAT °F	COP	HWC Mbtu/h	Airflow cfm	TC Mbtu/h	SC Mbtu/h	S/T Ratio	Power kW	HR Mbtu/h	EER	HWC Mbtu/h
20	10.0	2.9	6.8	Operation not recommended							Operation not recommended							
	13.0	4.6	10.5	Operation not recommended							Operation not recommended							
	16.0	6.6	15.1	1650	36.0	3.74	23.3	90.2	2.82	7.0	Operation not recommended							
				1850	37.8	3.79	24.8	88.9	2.92	6.3	Operation not recommended							
30	10.0	2.8	6.6	Operation not recommended							Operation not recommended							
	13.0	4.4	10.2	1650	39.7	3.81	26.7	92.3	3.05	6.9	1650	47.9	29.6	0.62	1.96	54.6	24.5	-
				1850	41.6	3.86	28.5	90.8	3.16	6.4	1850	48.7	32.4	0.66	2.06	55.8	23.6	-
	16.0	6.4	14.7	1650	41.4	3.81	28.4	93.2	3.19	7.1	1650	48.2	29.6	0.61	1.90	54.7	25.3	-
				1850	43.4	3.86	30.2	91.7	3.30	6.5	1850	49.4	32.4	0.66	2.00	56.2	24.7	-
	40	10.0	2.8	6.4	Operation not recommended							Operation not recommended						
13.0		4.3	9.9	1650	46.1	3.92	32.8	95.9	3.45	7.3	1650	52.8	34.3	0.65	2.17	60.2	24.3	-
				1850	48.2	3.93	34.8	94.1	3.59	6.7	1850	53.8	37.4	0.70	2.28	61.5	23.6	-
16.0		6.2	14.3	1650	47.8	3.93	34.4	96.8	3.56	7.5	1650	53.2	34.3	0.64	2.11	60.4	25.2	-
				1850	49.9	3.94	36.4	95.0	3.71	6.8	1850	54.4	37.4	0.69	2.21	61.9	24.6	-
50		10.0	2.7	6.2	1650	51.8	3.98	38.2	99.1	3.81	7.7	1650	57.3	37.1	0.65	2.44	65.7	23.5
	1850				54.1	3.94	40.7	97.1	4.03	7.1	1850	59.1	42.1	0.71	2.56	67.9	23.1	2.4
	13.0	4.2	9.6	1650	52.5	4.02	38.8	99.5	3.83	7.9	1650	57.5	37.4	0.65	2.35	65.5	24.4	2.1
				1850	54.7	4.00	41.0	97.4	4.00	7.3	1850	59.3	42.5	0.72	2.48	67.7	23.9	2.3
	16.0	6.0	13.8	1650	54.1	4.04	40.3	100.3	3.92	8.2	1650	57.6	37.4	0.65	2.29	65.5	25.1	2.0
				1850	56.4	4.02	42.7	98.2	4.11	7.5	1850	59.4	42.5	0.72	2.42	67.6	24.6	2.2
60	10.0	2.6	6.0	1650	57.7	4.11	43.7	102.4	4.12	8.5	1650	56.4	37.6	0.67	2.75	65.8	20.5	3.2
				1850	60.1	4.02	46.4	100.1	4.38	7.8	1850	58.1	42.5	0.73	2.88	67.9	20.2	3.4
	13.0	4.0	9.3	1650	59.3	4.15	45.2	103.3	4.19	8.7	1650	56.6	38.0	0.67	2.66	65.7	21.3	3.0
				1850	61.7	4.07	47.8	100.9	4.44	8.0	1850	58.3	43.0	0.74	2.79	67.8	20.9	3.3
	16.0	5.8	13.4	1650	60.7	4.19	46.4	104.1	4.24	9.0	1650	56.9	38.1	0.67	2.61	65.8	21.8	2.8
				1850	63.1	4.12	49.1	101.6	4.49	8.3	1850	58.6	43.1	0.73	2.72	67.9	21.5	3.1
70	10.0	2.5	5.8	1650	63.7	4.23	49.2	105.7	4.41	9.4	1650	55.5	38.2	0.69	3.07	65.9	18.1	4.5
				1850	66.3	4.11	52.2	103.2	4.73	8.7	1850	57.1	43.0	0.75	3.19	68.0	17.9	4.8
	13.0	3.9	9.0	1650	66.1	4.27	51.5	107.1	4.53	9.7	1650	55.8	38.6	0.69	2.97	65.9	18.8	4.2
				1850	68.7	4.15	54.5	104.4	4.85	8.9	1850	57.4	43.5	0.76	3.09	67.9	18.6	4.6
	16.0	5.6	12.9	1650	67.3	4.34	52.5	107.8	4.55	10.0	1650	56.1	38.8	0.69	2.93	66.1	19.1	3.9
				1850	69.9	4.21	55.5	105.0	4.86	9.2	1850	57.9	43.6	0.75	3.03	68.2	19.1	4.3
80	10.0	2.4	5.6	1650	69.3	4.32	54.6	108.9	4.70	10.6	1650	51.8	37.1	0.72	3.49	63.7	14.8	6.1
				1850	71.9	4.17	57.7	106.0	5.06	9.8	1850	48.5	41.5	0.86	3.59	60.8	13.5	5.9
	13.0	3.8	8.7	1650	73.0	4.37	58.1	111.0	4.89	10.9	1650	47.5	37.5	0.79	3.40	59.1	14.0	5.2
				1850	75.6	4.20	61.3	107.8	5.28	10.1	1850	48.9	42.0	0.86	3.50	60.9	14.0	5.6
	16.0	5.4	12.5	1650	73.8	4.43	58.7	111.4	4.88	11.3	1650	47.9	37.8	0.79	3.35	59.3	14.3	4.8
				1850	76.4	4.27	61.8	108.2	5.24	10.4	1850	54.3	42.3	0.78	3.44	66.0	15.8	5.8
90	10.0	2.3	5.4	1650	75.0	4.41	60.0	112.1	4.99	11.9	1650	48.1	36.1	0.75	3.91	61.5	12.3	8.2
				1850	77.5	4.23	63.1	108.8	5.38	11.0	1850	49.6	40.1	0.81	3.99	63.3	12.4	8.7
	13.0	3.6	8.4	1650	79.9	4.47	64.6	114.8	5.24	12.3	1650	48.6	36.5	0.75	3.83	61.7	12.7	7.6
				1850	82.5	4.25	68.1	111.3	5.70	11.4	1850	50.1	40.6	0.81	3.91	63.5	12.8	8.3
	16.0	5.2	12.1	1650	80.4	4.53	64.9	115.1	5.20	12.7	1650	49.1	36.8	0.75	3.77	62.0	13.0	7.1
				1850	82.9	4.33	68.1	111.5	5.61	11.7	1850	50.7	40.9	0.81	3.85	63.8	13.2	7.9
100	10.0	2.2	5.2	Operation not recommended							Operation not recommended							
	13.0	3.5	8.1	1650	45.5	35.7	0.79	4.36	60.4	10.4	9.7	Operation not recommended						
				1850	47.0	39.6	0.84	4.41	62.1	10.6	10.5	Operation not recommended						
	16.0	5.0	11.6	1650	46.1	36.2	0.78	4.30	60.8	10.7	9.0	Operation not recommended						
1850				47.5	40.0	0.84	4.35	62.4	10.9	10.0	Operation not recommended							
110	10.0	2.2	5.0	Operation not recommended							Operation not recommended							
	13.0	3.4	7.8	1650	42.4	35.0	0.83	4.90	59.1	8.7	12.9	Operation not recommended						
				1850	43.9	38.6	0.88	4.92	60.6	8.9	13.9	Operation not recommended						
	16.0	4.8	11.2	1650	43.1	35.6	0.82	4.83	59.6	8.9	11.9	Operation not recommended						
1850				44.4	39.2	0.88	4.85	61.0	9.1	13.3	Operation not recommended							
120	10.0	2.1	4.8	Operation not recommended							Operation not recommended							
	13.0	3.2	7.5	1650	39.1	34.2	0.87	5.49	57.9	7.1	15.7	Operation not recommended						
				1850	39.9	37.1	0.93	5.63	59.1	7.1	16.7	Operation not recommended						
	16.0	4.6	10.7	1650	39.5	34.2	0.87	5.31	57.6	7.4	14.4	Operation not recommended						
1850				40.3	37.1	0.92	5.48	59.0	7.4	15.9	Operation not recommended							

Performance capacities shown in thousands of Mbtu/h.

7/18/14

Wiring Schematics cont.

Aurora BASE with 5-Speed ECM cont.

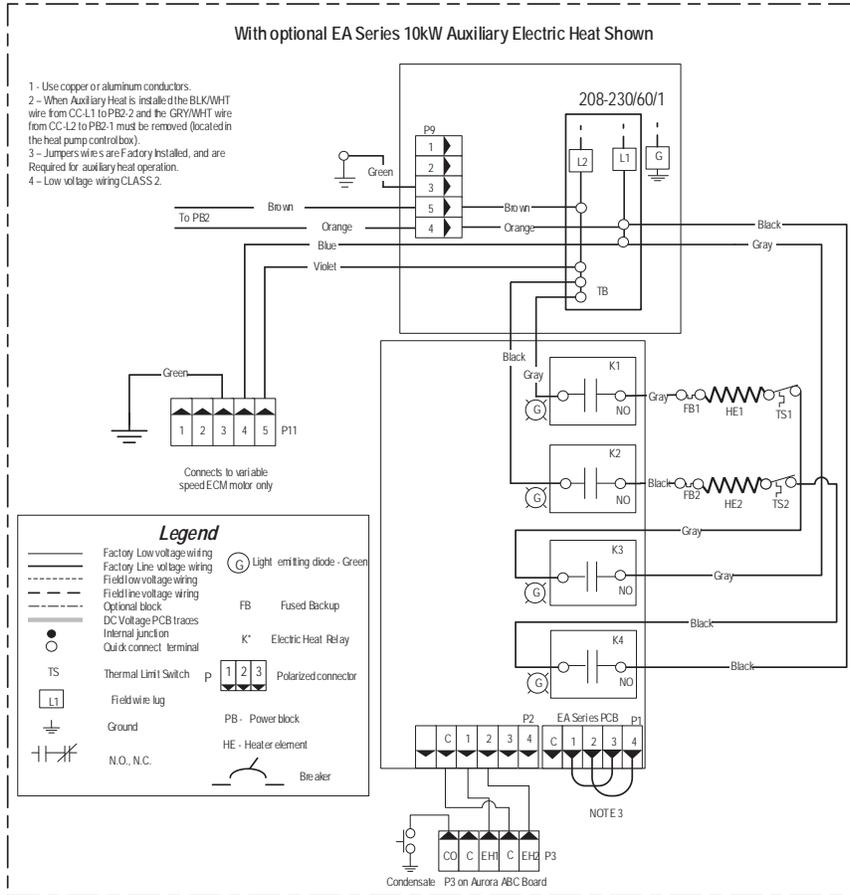

Aurora LED Flash Codes			
Slow Flash	1 second on and 1 second off		
Fast Flash	100 milliseconds on and 100 milliseconds off		
Flash Code	100 milliseconds on and 400 milliseconds off with a 2 second pause before repeating		
Random Start Delay (Alternating Colors)		Configuration LED (LED2, Yellow)	
Status LED (LED1, Green)	Fast Flash	No Software Override	OFF
Configuration LED (LED2, Yellow)	Fast Flash	DIP Switch Override	Slow Flash
Fault LED (LED3, Red)	Fast Flash		
Fault LED (LED1, Red)		Status LED (LED3, Green)	
Normal Mode	OFF	Normal Mode	ON
Input Fault Lockout	Flash Code 1	Control is Non-Functional	OFF
High Pressure Lockout	Flash Code 2	Test Mode	Slow Flash
Low Pressure Lockout	Flash Code 3	Lockout Active	Fast Flash
Future Use	Flash Code 4	Dehumidification Mode	Flash Code 2
Freeze Detection - FP1	Flash Code 5	Future Use	Flash Code 3
Reserved	Flash Code 6	Future Use	Flash Code 4
Condensate Overflow Lockout	Flash Code 7	Load Shed	Flash Code 5
Over/Under Voltage Shutdown	Flash Code 8	ESD	Flash Code 6
Future Use	Flash Code 9	Future Use	Flash Code 7
Future Use	Flash Code 10		
FP1 Sensor Error	Flash Code 11		

ABC SW2 Accessory Relay		
DESCRIPTION	SW2-4	SW2-5
Cycle with Blower	ON	ON
Cycle with Compressor	OFF	OFF
Water Valve Slow Opening	ON	OFF
Cycle with Comm. T-stat Hum Cmd	OFF	ON

Aurora Timing Events			
Event	Normal Mode	Test Mode	
Random Start Delay	5 to 80 seconds	1 second	
Compressor On Delay	5 seconds	< 1 second	
Compressor Minimum On Time	2 minutes	5 seconds	
Compressor Short Cycle Delay	4 minutes	15 seconds	
Blower Off Delay	30 seconds	2 seconds	
Fault Recognition Delay - High Pressure	Less than 1 second	Less than 1 second	
Start-Up Bypass - Low Pressure	2 minutes	30 seconds	
Fault Recognition Delay - Low Pressure	30 seconds	30 seconds	
Start-Up Bypass - Low Water Coil Limit	2 minutes	30 seconds	
Fault Recognition Delay - Low Water Coil Limit	30 seconds	30 seconds	
Fault Recognition Delay - Condensate Overflow	30 seconds	30 seconds	
Thermostat Call Recognition Time	2 seconds	2 seconds	
Comfort Alert Recognition Time	90 seconds	90 seconds	
Auxiliary Heat Staging Delay	5 minutes	20 seconds	
Emergency Heat Staging Delay	2 minutes	7.5 seconds	
Water Valve Slow Open Delay	90 seconds	90 seconds	

5 SPEED ECM MOTOR LOW VOLTAGE CONNECTIONS					
Model	TAP-1	TAP-2	TAP-3	TAP-4	TAP-5
024	BLUE	RED		TAN	GRAY
036	BLUE	RED		TAN	GRAY
048	BLUE	RED		TAN	GRAY
060	BLUE	RED		TAN	GRAY
072	BLUE	RED		TAN	GRAY

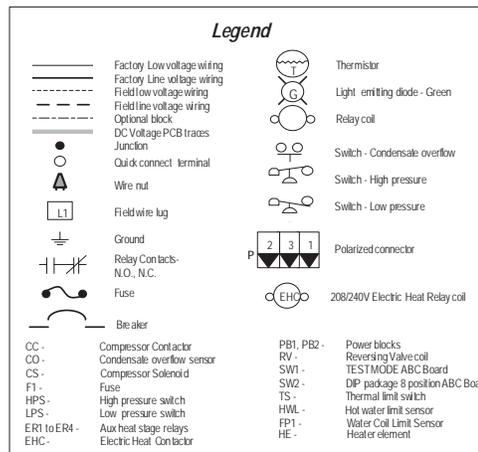
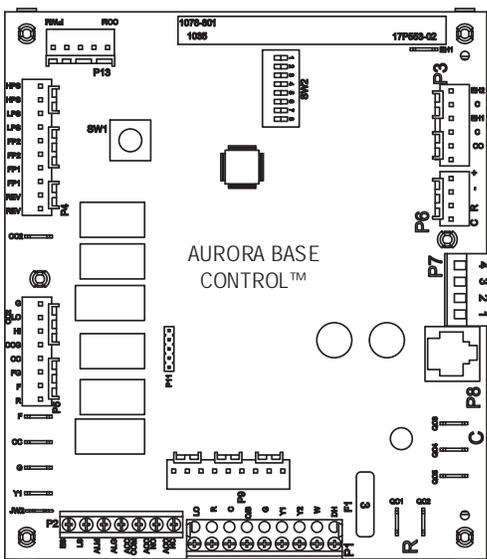

Wiring Schematics cont.

Aurora BASE with 5 Speed ECM and IntelliStart

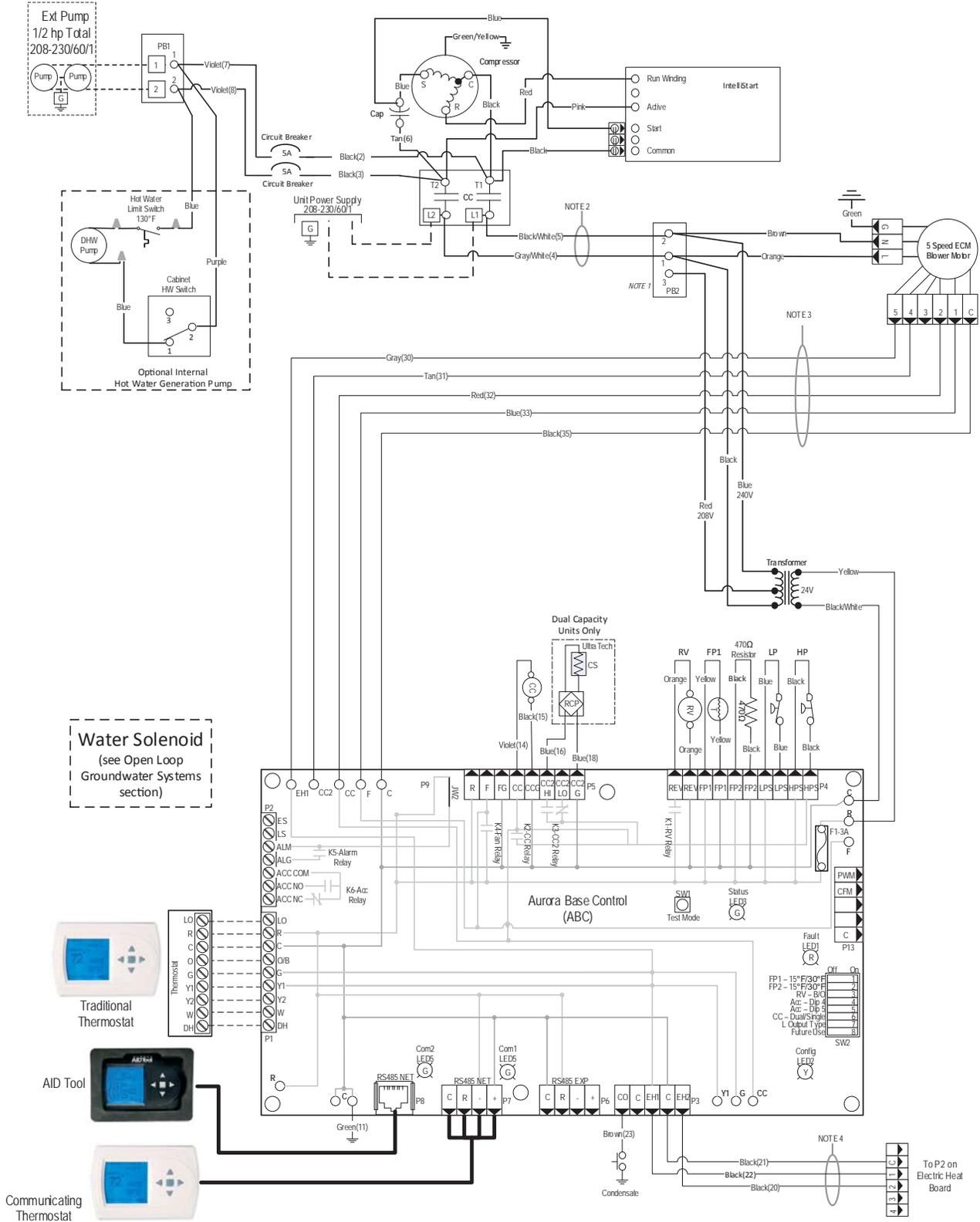

Wiring Schematics cont.

Aurora BASE with 5 Speed ECM and IntelliStart

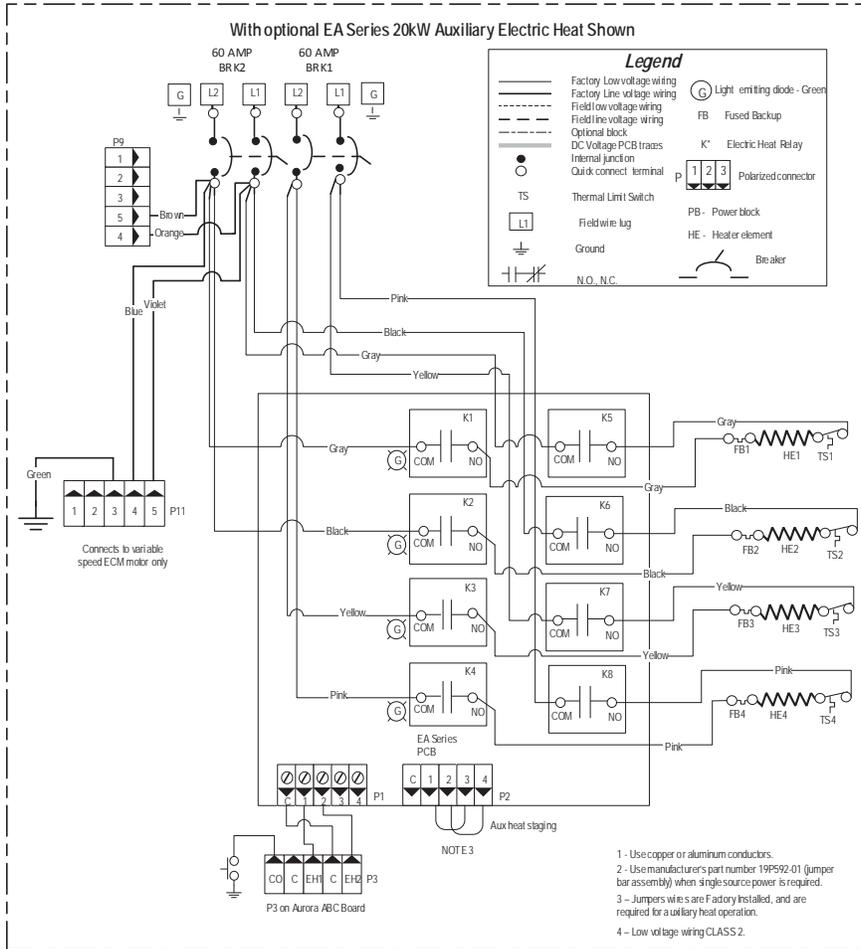

Aurora LED Flash Codes

Slow Flash	1 second on and 1 second off
Fast Flash	100 milliseconds on and 100 milliseconds off
Flash Code	100 milliseconds on and 400 milliseconds off with a 2 second pause before repeating
Status LED (LED1, Green)	Fast Flash No Software Override OFF
Configuration LED (LED2, Yellow)	Fast Flash DIP Switch Override Slow Flash
Fault LED (LED3, Red)	Fast Flash
Fault LED (LED1, Red)	
Normal Mode	OFF Normal Mode ON
Input Fault Lockout	Flash Code 1 Control is Non-Functional OFF
High Pressure Lockout	Flash Code 2 Test Mode Slow Flash
Low Pressure Lockout	Flash Code 3 Lockout Active Fast Flash
Future Use	Flash Code 4 Dehumidification Mode Flash Code 2
Freeze Detection - FP1	Flash Code 5 Future Use Flash Code 3
Reserved	Flash Code 6 Future Use Flash Code 4
Condensate Overflow Lockout	Flash Code 7 Load Shed Flash Code 5
Over/Under Voltage Shutdown	Flash Code 8 ESD Flash Code 6
Future Use	Flash Code 9 Future Use Flash Code 7
Future Use	Flash Code 10
FP1 Sensor Error	Flash Code 11

ABC SW2 Accessory Relay

DESCRIPTION	SW2-4	SW2-5
Cycle with Blower	ON	ON
Cycle with Compressor	OFF	OFF
Water Valve Slow Opening	ON	OFF
Cycle with Comm. T-stat Hum Cmd	OFF	ON

Aurora Timing Events

Event	Normal Mode	Test Mode
Random Start Delay	5 to 80 seconds	1 second
Compressor On Delay	5 seconds	< 1 second
Compressor Minimum On Time	2 minutes	5 seconds
Compressor Short Cycle Delay	4 minutes	15 seconds
Blower Off Delay	30 seconds	2 seconds
Fault Recogn Delay - High Pressure	Less than 1 second	Less than 1 second
Start-Up Bypass - Low Pressure	2 minutes	30 seconds
Fault Recogn Delay - Low Pressure	30 seconds	30 seconds
Start-Up Bypass - Low Water Coil Limit	2 minutes	30 seconds
Fault Recogn Delay - Low Water Coil Limit	30 seconds	30 seconds
Fault Recogn Delay - Condensate Overflow	30 seconds	30 seconds
Thermostat Call Recognition Time	2 seconds	2 seconds
Comfort Alert Recognition Time	90 seconds	90 seconds
Auxiliary Heat Staging Delay	5 minutes	20 seconds
Emergency Heat Staging Delay	2 minutes	7.5 seconds
Water Valve Slow Open Delay	90 seconds	90 seconds

5 SPEED ECM MOTOR LOW VOLTAGE CONNECTIONS

Model	TAP-1	TAP-2	TAP-3	TAP-4	TAP-5
024	BLUE	RED		TAN	GRAY
036	BLUE	RED		TAN	GRAY
048	BLUE	RED		TAN	GRAY
060	BLUE	RED		TAN	GRAY
072	BLUE	RED		TAN	GRAY

Notes

- 1 - Switch blue and red wires for 208V operation.
- 2 - The black and gray wires are removed when Aux Heat is installed.
- 3 - Refer to units X13 MOTOR LOW VOLTAGE CONNECTION table for factory settings.
- 4 - Wires provided for Auxiliary Heat low voltage control. When connected the Auxiliary Heat powers blower and controls. Wires are secured at blower.
- 5 - Field installed SPST relay required for dual fuel installation.
- 6 - All low voltage wiring CLASS 2
- 7 - Use copper or aluminum conductors

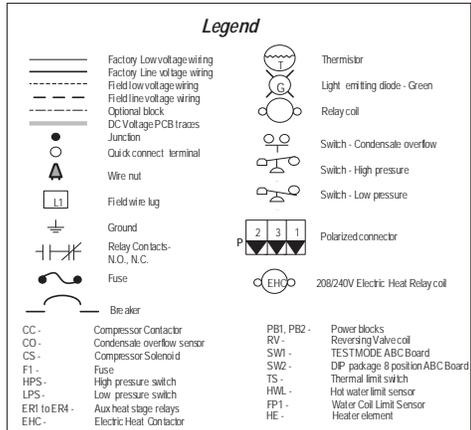
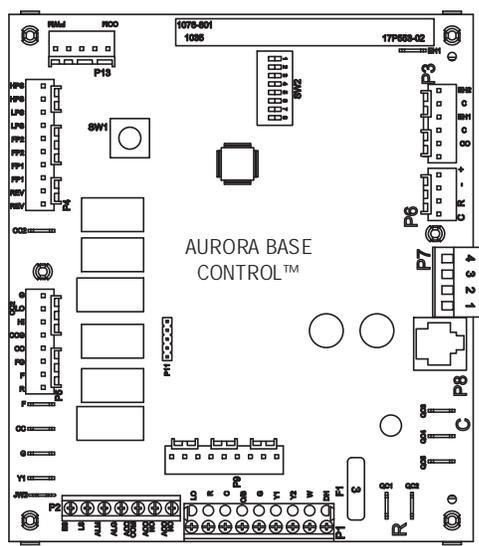

Engineering Guide Specifications

General

Furnish and install Water Source Heat Pumps, as indicated on the plans. Equipment shall be completely assembled, piped and internally wired. Capacities and characteristics as listed in the schedule and the specifications that follow. The reverse cycle heating/cooling units shall be either suspended type with horizontal air inlet and discharge or floor mounted type with horizontal air inlet and vertical upflow air discharge. Units shall be AHRI/ISO 13256-1 certified and listed by a nationally recognized safety-testing laboratory or agency, such as ETL Testing Laboratory. Each unit shall be computer run-tested at the factory with conditioned water and operation verified to catalog data. Each unit shall be mounted on a pallet and shipped in a corrugated box or stretch-wrapped. The units shall be designed to operate with entering liquid temperature between 20°F and 120°F [-6.7°C and 48.9°C].

Casing and Cabinet

The cabinet shall be fabricated from heavy-gauge galvanized steel and finished with corrosion-resistant powder coating. This corrosion protection system shall meet the stringent 1000 hour salt spray test per ASTM B117. The interior shall be insulated with 1/2-inch thick, multi-density, cleanable aluminum foil coated glass fiber with edges sealed or tucked under flanges to prevent the introduction of glass fibers into the discharge air. Standard cabinet panel insulation must meet NFPA 90A requirements, air erosion and mold growth limits of UL-181, stringent fungal resistance test per ASTM-C1071 and ASTM G21, and shall meet zero level bacteria growth per ASTM G22. Unit insulation must meet these stringent requirements or unit(s) will not be accepted.

One (horizontal) to two (vertical) blower and three compressor compartment access panels shall be 'lift-out' removable with supply and return ductwork in place. The front access panel shall be lift-out to provide easy access to the electrical/compressor section. The internal component layout shall provide for service access from the front side for restricted installations.

A duct collar shall be provided on the supply air opening. A duct flange shall be provided for the return air opening. Standard size 1 in. [2.5 cm] MERV 8 pleated filters shall be optional with filter rack or filter rails. The upflow vertical units shall have a removable insulated divider panel between the air handling section and the compressor section to minimize the transmission of compressor noise and to permit operational service testing without air bypass. Vertical units shall be supplied with left or right horizontal air inlet and top air discharge. Horizontal units shall be supplied with left or right air inlet and side or end air discharge. The compressor shall be double isolation mounted using selected durometer grommets to provide vibration free compressor mounting.

The drain pan shall be of plastic construction to inhibit corrosion and bacterial growth. Drain outlet shall be located on pan as to allow complete and unobstructed drainage of condensate. The unit as standard will be supplied with solid-state electronic condensate overflow protection. Mechanical float switches WILL NOT be accepted. Vertical units shall be furnished with a PVC slip condensate drain connection and an internal factory installed condensate trap.

Refrigerant Circuit

All units shall contain a sealed refrigerant circuit including a hermetic motor-compressor, discharge line muffler, bidirectional thermostatic expansion valve, all aluminum finned tube air-to-refrigerant heat exchanger, reversing valve, coaxial tube water-to-refrigerant heat exchanger, optional hot water generator coil, and service ports.

Compressors shall be high-efficiency dual capacity scroll type designed for heat pump duty and mounted on vibration isolators. Compressor motors shall be single-phase PSC with overload protection. The coil shall be sized for low-face velocity and constructed of lanced aluminum fins bonded to aluminum tubes in a staggered pattern not less than three rows deep for enhanced performance. Models shall include discharge mufflers to help quiet compressor discharge gas pulsations. Refrigerant to air heat exchangers shall utilize aluminum tube construction rated to withstand 600 psig (4135 kPa) refrigerant working pressure.

The coaxial water-to-refrigerant heat exchanger shall be designed for low water pressure drop and constructed of a convoluted copper (cupronickel option) inner tube and a steel outer tube. Refrigerant to water heat exchangers shall be of copper inner water tube and steel refrigerant outer tube design, rated to withstand 600 psig (4135 kPa) working refrigerant pressure and 450 psig (3101 kPa) working water pressure. The thermostatic expansion valve shall provide proper superheat over the entire liquid temperature range with minimal "hunting." The valve shall operate bidirectionally without the use of check valves.

All units shall have the source coaxial tube refrigerant-to-water heat exchanger and the optional hot water generator coil shall be coated with ThermaShield. Refrigerant suction lines shall be insulated to prevent condensation at low liquid temperatures.

Blower Motor and Assembly

The blower shall be a direct drive centrifugal type with a dynamically balanced wheel. The housing and wheel shall be designed for quiet low outlet velocity operation. The blower housing shall be removable from the unit without disconnecting the supply air ductwork for servicing of the blower motor. The blower motor shall be a 5-speed ECM.

The ECM blower motor shall be soft starting, and shall provide 5 TAP settings. The blower motor shall be isolated from the housing by rubber grommets. The motor shall be permanently lubricated and have thermostatic overload protection. 5-speed ECM motors shall be long-life ball bearing type.

Engineering Guide Specifications cont.

Electrical

A control box shall be located within the unit compressor compartment and shall contain a 75VA transformer, 24 volt activated, 2 pole compressor contactor, circuit breakers for protecting loop pumps, terminal block for thermostat wiring, and solid-state controller for complete unit operation. Electromechanical operation WILL NOT be accepted. Units shall be name-plated for use with time delay fuses or HACR circuit breakers. Unit controls shall be 24 volt and provide heating or cooling as required by the remote thermostat/sensor. An Aurora, a microprocessor-based controller, interfaces with a multi-stage electronic thermostat to monitor and control unit operation shall be provided. The control shall provide operational sequencing, blower speed control, high and low pressure switch monitoring, freeze detection, condensate overflow sensing, auxiliary heat staging, lockout mode control, and loop pump control, LED status and fault indicators, fault memory, field selectable options, and accessory output. The Lockout signal output shall have a pulsed option so that DDC systems can read specific lockout conditions from the control.

A detachable terminal block with screw terminals will be provided for field control wiring. All units shall have knockouts for entrance of low and line voltage wiring. The blower motor and control box shall be harness plug wired for easy removal.

An optional Aurora Interface Diagnostic (AID) Tool shall communicate with the Aurora control allowing quick and easy access to setup, monitoring, and troubleshooting of any Aurora control. The device shall include the features of fault description and history, manual operation capability, sensor readings, timings, and other diagnostic tools.

Optional IntelliStart® (compressor Soft Starter) shall be factory installed for use in applications that require low starting amps, reduced compressor start-up noise, off-grid, and improved start-up behavior. IntelliStart shall reduce normal starting current by up to 60%.

Piping

Supply and return water connections shall be 1 in. [25.4 mm] FPT brass swivel fittings, which provide a union and eliminate the need for pipe wrenches and sealants when making field connections. The optional hot water generator shall have sweat type connections. All water piping shall be insulated to prevent condensation at low liquid temperatures, on the vertical units, the condensate connection shall be a 3/4 in. [19.1 mm] PVC socket with internally-trapped hose that can be routed to front or side locations.

Hanger Kit

(field-installed horizontal units only)

The hanger kit shall consist of galvanized steel brackets, bolts, lock washers, and isolators and shall be designed to fasten to the unit bottom panel for suspension from 3/8-inch threaded rods. Unit sizes 024-036 shall include four brackets. Unit sizes 048-072 shall include six brackets.

Options and Accessories

Cupronickel Heat Exchanger

An optional cupronickel water-to-refrigerant heat exchanger shall be provided.

Hot Water Generator

An optional ThermaShield coated heat reclaiming hot water generator coil of vented double-wall copper construction suitable for potable water shall be provided. The coil and hot water circulating pump shall be factory mounted inside the unit with integral electronic high limit temperature monitoring and external on/off switch.

Thermostat (field-installed)

A multi-stage auto-changeover electronic digital thermostat shall be provided. The thermostat shall offer three heating and two cooling stages with precise temperature control. An OFF-HEAT-AUTO-COOL-EMERG system switch, OFF-AUTO blower switch, and indicating LEDs shall be provided. The thermostat shall display in °F or °C. The thermostat shall be either a communicating type or a traditional 24 VAC type.

Communicating Thermostat (field-installed)

A communicating auto-changeover electronic digital thermostat shall be provided. The thermostat shall offer variable speed heating and cooling staging with precise temperature control. An OFF-HEAT-AUTO-COOL-EMERG system switch, OFF-AUTO blower switch, and indicating display shall be provided. The thermostat shall display in °F or °C.

Communicating Color Touchscreen Thermostat (field-installed)

A color touchscreen communicating auto-changeover electronic digital thermostat shall be provided. The thermostat shall offer variable speed heating and cooling staging with precise temperature control. An OFF-HEAT-AUTO-COOL-EMERG system switch, OFF-AUTO blower switch, and indicating display shall be provided. The thermostat shall display in °F or °C.

Electronic Air Cleaner (field-installed)

A 1 in. [25 mm] electronic air cleaner, cleanable 97% efficiency at 0.3 microns and larger, shall be provided in lieu of the standard throwaway filter. The initial pressure drop across the filter shall not exceed 0.2 in. w.g. at 300 fpm force velocity.

Engineering Guide Specifications cont.

Electrostatic Air Cleaner (field-installed)

A 1 in. [25 mm] electrostatic air cleaner, cleanable 90% efficiency, shall be provided in lieu of the standard throwaway filter. The initial pressure drop across the filter shall not exceed 0.15 in. w.g. at 300 fpm force velocity.

AlpinePure Drain Pan Treatment (field-installed)

Provides dependable, sustained time-release protection from slime build-up and foul smelling odors in the drain pan. Also adds a light, pleasant scent to the air.

Earth Loop Flow Center (field-installed)

A self-contained module shall provide all liquid flow, fill and connection requirements for ground source closed loop systems up to 20 gpm. The pumps shall be wired to a power block located in the nearest unit. The heat pump units shall contain low voltage pump linking control so that two units may share one flow center.

Auxiliary Heater (field-installed)

An electric resistance heater shall provide supplemental and/or emergency heating capability. Vertical units shall have the control panel and resistance heater coil assembly mounted internally. For horizontal units, the control panel shall be mounted internally while the resistance heater coil assembly shall be mounted externally. A low voltage plug shall be provided in each unit for quick auxiliary heat connection. The heater shall operate in sequenced stages as controlled by the unit's microprocessor. The heater shall feed line voltage power to the unit blower and transformer to provide emergency heat capability in the event of an open compressor circuit breaker.

Revision Guide

Pages:	Description:	Date:	By:
Misc.	Updated AHRI Data, Misc. Updates	01 Feb 2018	JM
Misc.	Updated Wiring Schematics, Physical Data, Added Aurora WebLink Info	14 Dec 2016	MA
All	Literature Creation	18 Sept 2014	MA



Product: **LX Series**
Type: Geothermal Heat Pumps
Size: 2-6 Ton Dual Capacity

Document Type: Specification Catalog
Part Number: SC2300AK6
Release Date: 03/18