



Heating and Air Conditioning

SPECIFICATION CATALOG

LX ULTRA

**COMMERCIAL GEOTHERMAL/
WATER SOURCE HEAT PUMPS
SINGLE CAPACITY**

MODELS:

YGS009 - 070

(.75 THRU 6 NOMINAL TONS)



Due to continuous product improvement, specifications are subject to change without notice.

Visit us on the web at www.yorkgeothermal.com

Additional rating information can found at www.ahridirectory.org

FOR DISTRIBUTION USE ONLY - NOT TO BE USED AT POINT OF RETAIL SALE

Table of Contents

Model Nomenclature 4

AHRI Data 5-7

The LX Ultra Series 7-12

Inside the LX Ultra Series..... 12-14

Controls 15-18

Hot Gas Reheat Dehumidification Overview 19-21

Hot Gas Reheat 22

Application Notes 23-25

Water Quality 25

Installation Notes 23-28

Vertical Dimensional Data 29-30

Horizontal Dimensional Data 31-32

Hanger Bracket Locations 33

Physical Data 34

Electrical Availability 35

Electrical Data 36-38

Blower Performance Data 39-42

Selection Example 43-44

Reference Calculations 45

Legend and Notes 45

Operating Limits 46

Correction Factor Tables 46

Pressure Drop 47

Performance Data 48-71

Wiring Schematics 72-73

Engineering Guide Specifications..... 74-76

Revision Guide..... 77

Model Nomenclature

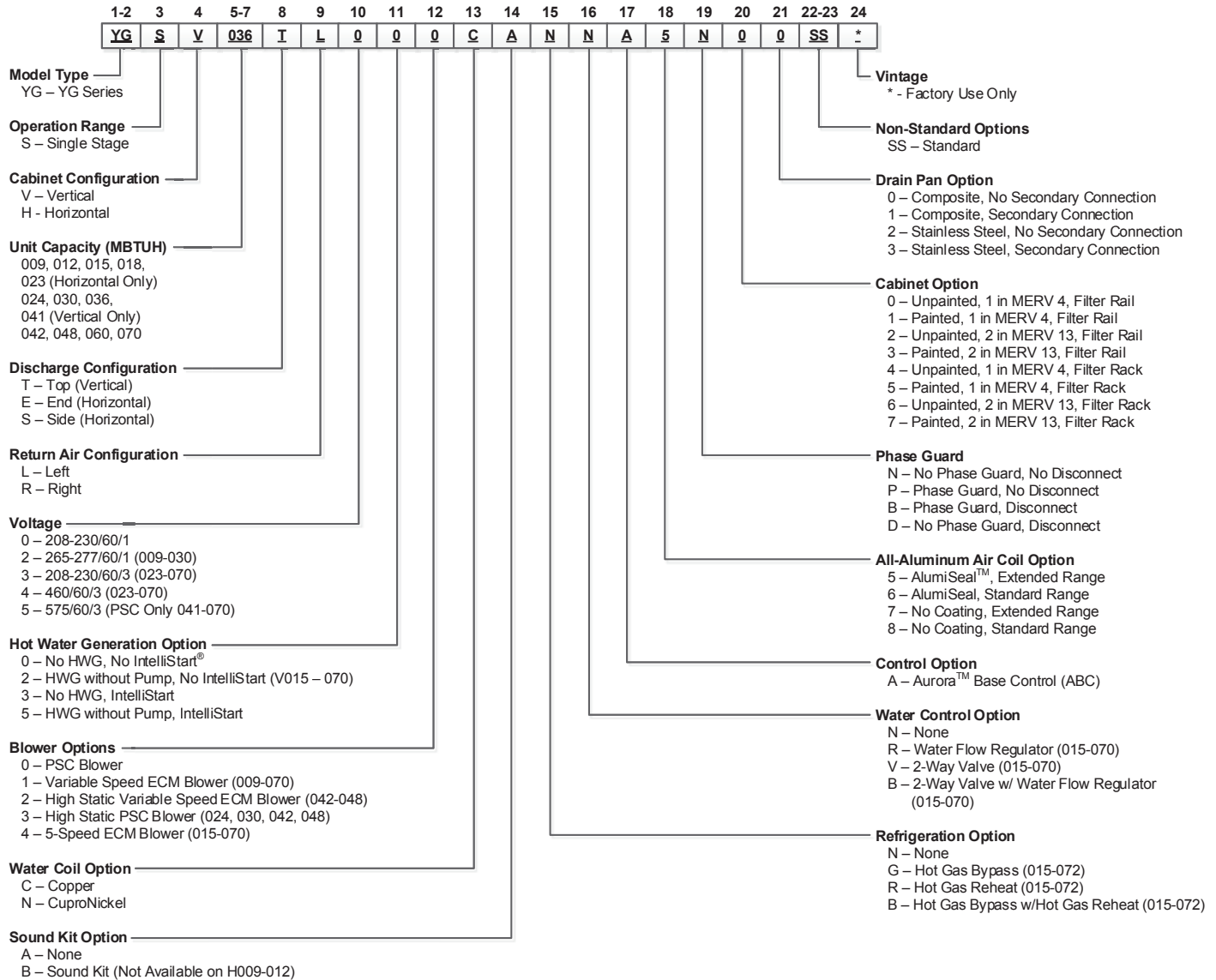

Note: Phase Guard Only Available on 208-230/60/3 and 460/60/3 50VA Transformer with Aurora

AHRI Data

PSC Motors
 AHRI/ASHRAE/ISO 13256-1
 English (IP) Units

Model	Flow Rate		Water Loop Heat Pump				Ground Water Heat Pump				Ground Loop Heat Pump			
			Cooling EWT 86°F		Heating EWT 68°F		Cooling EWT 59°F		Heating EWT 50°F		Cooling EWT 77°F		Heating EWT 32°F	
	gpm	cfm	Capacity Btuh	EER Btuh/W	Capacity Btuh	COP	Capacity Btuh	EER Btuh/W	Capacity Btuh	COP	Capacity Btuh	EER Btuh/W	Capacity Btuh	COP
009	3.0	350	8,500	12.2	11,500	4.4	10,500	18.2	9,600	3.7	9,100	13.5	7,600	3.0
012	3.5	400	10,900	12.7	14,700	4.4	12,500	18.2	12,000	3.8	11,500	14.7	9,600	3.2
015	4.0	500	14,000	15.0	16,500	4.8	16,000	24.0	15,000	4.1	14,700	17.2	11,500	3.5
018	5.0	600	17,600	14.6	21,000	4.7	20,600	23.5	17,500	4.0	18,500	17.0	13,700	3.5
023	6.0	800	23,000	14.5	26,000	4.5	25,400	22.5	21,900	3.9	23,900	16.8	17,000	3.4
024	6.0	800	23,900	14.6	27,000	4.7	26,400	22.8	22,300	4.0	24,400	17.0	17,500	3.5
030	8.0	1000	29,500	14.9	34,600	4.8	32,900	23.0	28,300	4.0	29,000	17.0	22,800	3.5
036	9.0	1150	33,300	14.4	40,600	4.5	37,700	21.2	33,000	3.9	34,500	16.6	26,000	3.3
041	11.0	1300	40,000	13.8	45,000	4.3	44,500	20.6	36,000	3.8	41,000	15.8	29,000	3.3
042	11.0	1400	40,800	14.5	45,400	4.5	45,800	22.0	37,000	3.8	42,300	16.8	29,900	3.3
048	12.0	1600	47,700	14.7	56,000	4.4	52,000	21.0	45,900	3.8	49,500	16.8	36,900	3.3
060	15.0	1900	58,400	14.7	72,500	4.4	65,500	20.8	58,400	3.8	60,900	16.6	47,100	3.3
070	18.0	2100	63,000	14.2	79,000	4.4	70,000	20.3	64,100	3.8	68,500	15.2	51,600	3.3

5/25/16

Cooling capacities based upon 80.6°F DB, 66.2°F WB entering air temperature
 Heating capacities based upon 68°F DB, 59°F WB entering air temperature
 All ratings based upon 208V operation

Variable Speed ECM, or 5-Speed ECM Motor
 AHRI/ASHRAE/ISO 13256-1
 English (IP) Units

Model	Flow Rate		Water Loop Heat Pump				Ground Water Heat Pump				Ground Loop Heat Pump			
			Cooling EWT 86°F		Heating EWT 68°F		Cooling EWT 59°F		Heating EWT 50°F		Cooling EWT 77°F		Heating EWT 32°F	
	gpm	cfm	Capacity Btu/h	EER Btu/h/W	Capacity Btu/h	COP	Capacity Btu/h	EER Btu/h/W	Capacity Btu/h	COP	Capacity Btu/h	EER Btu/h/W	Capacity Btu/h	COP
015	4.0	500	14,000	15.3	16,500	4.9	16,000	24.3	15,000	4.4	14,700	17.5	11,500	3.7
018	5.0	600	17,600	15.2	21,000	4.8	20,600	24.0	17,500	4.4	18,500	17.5	13,700	3.7
023	6.0	800	23,000	15.0	26,000	4.7	25,400	23.0	21,900	4.3	23,900	17.0	17,000	3.6
024	6.0	800	23,900	15.1	27,000	5.0	26,400	23.4	22,300	4.5	24,400	17.5	17,500	3.8
030	8.0	900	29,500	15.7	34,600	5.1	32,900	23.9	28,300	4.4	29,000	18.3	22,800	3.8
036	9.0	1150	33,300	15.0	40,600	4.8	37,700	23.0	33,000	4.3	34,500	17.3	26,000	3.5
041	11.0	1300	40,000	14.5	45,000	4.5	44,500	22.0	36,000	4.0	41,000	16.5	29,000	3.4
042	11.0	1400	40,800	15.6	45,400	5.0	45,800	23.5	37,000	4.3	42,300	18.5	29,900	3.7
048	12.0	1600	47,700	15.5	56,000	4.8	52,000	23.4	45,900	4.2	49,500	18.1	36,900	3.6
060	15.0	1900	58,400	15.3	72,500	4.7	65,500	23.0	58,400	4.0	60,900	17.9	47,100	3.6
070	18.0	2100	63,000	14.3	79,000	4.7	70,000	21.0	64,100	4.0	68,500	16.1	51,600	3.5

12/6/10

Cooling capacities based upon 80.6°F DB, 66.2°F WB entering air temperature
 Heating capacities based upon 68°F DB, 59°F WB entering air temperature
 All ratings based upon 208V operation



All LX Ultra Series product is safety listed under UL1995 thru ETL and performance listed with AHRI in accordance with standard 13256-1.

AHRI Data cont.

The performance standard AHRI/ASHRAE/ISO 13256-1 became effective January 1, 2000 and replaces AHRI Standards 320, 325, and 330. This new standard has three major categories: Water Loop (comparable to ARI 320), Ground Water (ARI 325), and Ground Loop (ARI 330). Although these standards are similar there are some differences:

Unit of Measure: The Cooling COP

The cooling efficiency is measured in EER (US version measured in Btuh per Watt. The Metric version is measured in a cooling COP (Watt per Watt) similar to the traditional COP measurement.

Water Conditions Differences

Entering water temperatures have changed to reflect the centigrade temperature scale. For instance the water loop heating test is performed with 68°F (20°C) water rounded down from the old 70°F (21.1°C).

Air Conditions Differences

Entering air temperatures have also changed (rounded down) to reflect the centigrade temperature scale. For instance the cooling tests are performed with 80.6°F (27°C) dry bulb and 66.2°F (19°C) wet bulb entering air instead of the traditional 80°F (26.7°C) DB and 67°F (19.4°C) WB entering air temperatures. 80.6/66.2 data may be converted to 80/67 using the entering air correction table. This represents a significantly lower relative humidity than the old 80/67 of 50% and will result in lower latent capacities.

Pump Power Correction Calculation

Within each model, only one water flow rate is specified for all three groups and pumping Watts are calculated using the following formula. This additional power is added onto the existing power consumption.

- Pump power correction = (gpm x 0.0631) x (Press Drop x 2990) / 300

Where 'gpm' is waterflow in gpm and 'Press Drop' is the pressure drop through the unit heat exchanger at rated water flow in feet of head.

Fan Power Correction Calculation

Fan power is corrected to zero external static pressure using the following equation. The nominal airflow is rated at a specific external static pressure. This effectively reduces the power consumption of the unit and increases cooling capacity but decreases heating capacity. These Watts are significant enough in most cases to increase EER and COPs fairly dramatically over ARI 320, 325, and 330 ratings.

- Fan Power Correction = (cfm x 0.472) x (esp x 249) / 300

Where 'cfm' is airflow in cfm and 'esp' is the external static pressure at rated airflow in inches of water gauge.

ISO Capacity and Efficiency Calculations

The following equations illustrate cooling calculations:

- ISO Cooling Capacity = Cooling Capacity (Btuh) + (Fan Power Correction (Watts) x 3.412)
- ISO EER Efficiency (W/W) = ISO Cooling Capacity (Btuh) x 3.412 / [Power Input (Watts) - Fan Power Correction (Watts) + Pump Power Correction (Watt)]

The following equations illustrate heating calculations:

- ISO Heating Capacity = Heating Capacity (Btuh) - (Fan Power Correction (Watts) x 3.412)
- ISO COP Efficiency (W/W) = ISO Heating Capacity (Btuh) x 3.412 / [Power Input (Watts) - Fan Power Correction (Watts) + Pump Power Correction (Watt)]

Comparison of Test Conditions

	ARI 320	ISO/AHRI 13256-1 WLHP	ARI 325	ISO/AHRI 13256-1 GWHP	ARI 330	ISO/AHRI 13256-1 GLHP
Cooling						
Entering Air - DB/WB °F	80/67	80.6/66.2	80/67	80.6/66.2	80/67	80.6/66.2
Entering Water - °F	85	86	50/70	59	77	77
Fluid Flow Rate	*	**	**	**	**	**
Heating						
Entering Air - DB/WB °F	70	68	70	68	70	68
Entering Water - °F	70	68	50/70	50	32	32
Fluid Flow Rate	*	**	**	**	**	**

Note *: Flow rate is set by 10°F rise in standard cooling test
Part load entering water conditions not shown.

Note **: Flow rate is specified by the manufacturer

WLHP = Water Loop Heat Pump; GWHP = Ground Water Heat Pump; GLHP = Ground Loop Heat Pump

Conversions:

Airflow (lps) = CFM x 0.472;

ESP (Pascals) = ESP (in wg) x 249;

Water Flow (lps) = GPM x 0.0631;

Press Drop (Pascals) = Press Drop (ft hd) x 2990

The LX Ultra Series

The LX Ultra Series represents a significant improvement in the commercial water source heat pump (wshp). The R-410A product features high efficiency with industry leading standard options in a compact cabinet suitable for both retrofit and new construction applications. The product is also targeted to provide optimum performance and flexibility in both water loop and geothermal applications. The new product features the following options (see nomenclature for more details):

- Wide selection of capacities from 009-070 MBtu/h output
- Complete commercial voltage selection of 208-230 V/60 Hz/1ph, 265/60/1, 208-230/60/3, 460/60/3, and 575/60/3
- All-Aluminum rifled tube-and-fin air coils are not susceptible to formicary corrosion.
- Industry leading quality through engineering and manufacturing using quality components
 - High Efficiency and reliable rotary compressors 009-018
 - High Efficiency and reliable scroll compressors 023-070
 - High Efficiency 3 speed PSC blower motor, 5-speed ECM blower motor, or optional variable speed ECM
- High efficiency performance for maximizing LEED points
 - With PSC Blower Motor Up to 15.0 EER and 4.8 COP (ISO/AHRI 13256-1-WLHP)
 - With Variable ECM Blower Motor Up to 15.7 EER and 5.1 COP (ISO/AHRI 13256-1-WLHP)
 - With 5-Speed ECM Blower Motor Up to 15.7 EER and 5.1 COP (ISO/AHRI 13256-1-WLHP)
- Small cabinet footprint for easy retrofit of much lower efficiency legacy product
 - Compact height and length horizontal cabinet matches legacy product - 11.9 in. high 009-0012, 17 in. high 015-018, 19 in. high 024-036, and 21 in. high 042-070
 - Short vertical cabinet
 - Special models for specific replacement sizes
 - Horizontal 023 model is 22.5 in. wide x 17.2 in. high x 42.0 in. long
 - Vertical 041 model is 22.5 in. wide x 26.2 in. deep x 44.2 in. high
- Wide array of standard factory installed options including:
 - Configurations – horizontal left and right return, end or side discharge (field switchable); vertical left and right return
 - 3 speed PSC, 5-speed ECM, or variable speed ECM blower motor with high static options
 - Internal hot water generator coil (vertical only)
 - Copper or cupronickel heat exchanger and optional low temperature insulation
 - Hot Gas reheat and/or bypass
 - Corrosion-proof composite or stainless steel drain pan; including internally mounted secondary drain connection option
 - Filter options: standard 1 in. MERV 4 or optional 2 in. MERV 13 factory installed with either filter rails or optional deluxe filter rack both field switchable between 1 in. and 2 in.
 - Aurora Base Control
 - Factory mounted internal water valve and/or flow regulator for variable speed pumping systems saving on installation costs
 - Other Options: Sound Kit, coated air coil, phase guard, factory mounted power disconnect, IntelliStart soft starter, painted cabinet



Vertical LX Ultra Series

Models YGSV009-070 (3/4-6 tons) Single Speed

Horizontal LX Ultra Series

Models YGSH009-070 (3/4-6 tons) Single Speed

The LX Ultra Series cont.

Product Features: Vertical Cabinet

LX Ultra Series vertical units are designed for high efficiency, maximum flexibility, and primary servicing from the front.

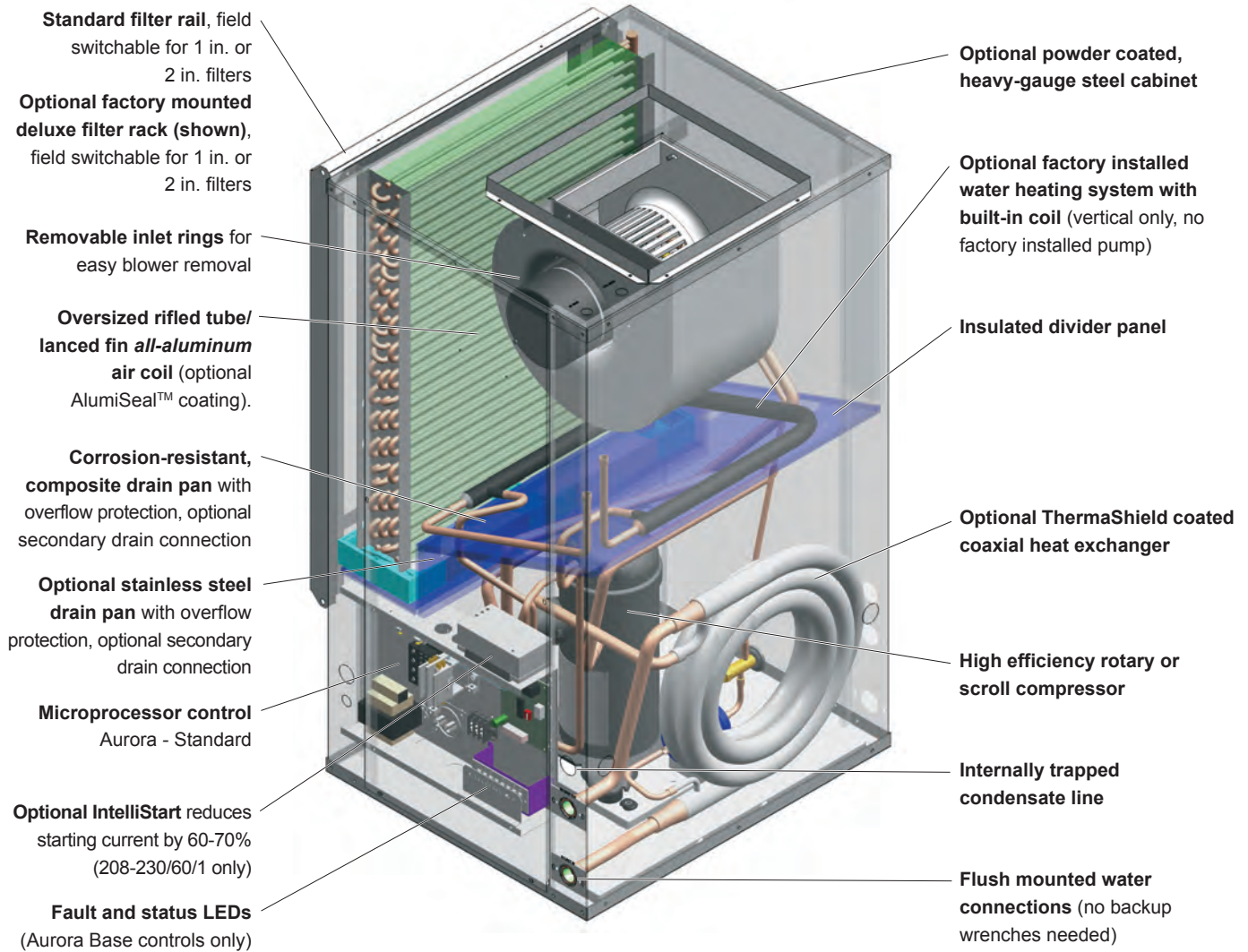

A true left and right return option is available.

The LX Ultra Series cont.

Product Features: Horizontal Cabinet

LX Ultra Series Horizontal units are available in seven cabinet sizes. The cabinets are designed for high efficiency, maximum flexibility, and primary servicing from the front.

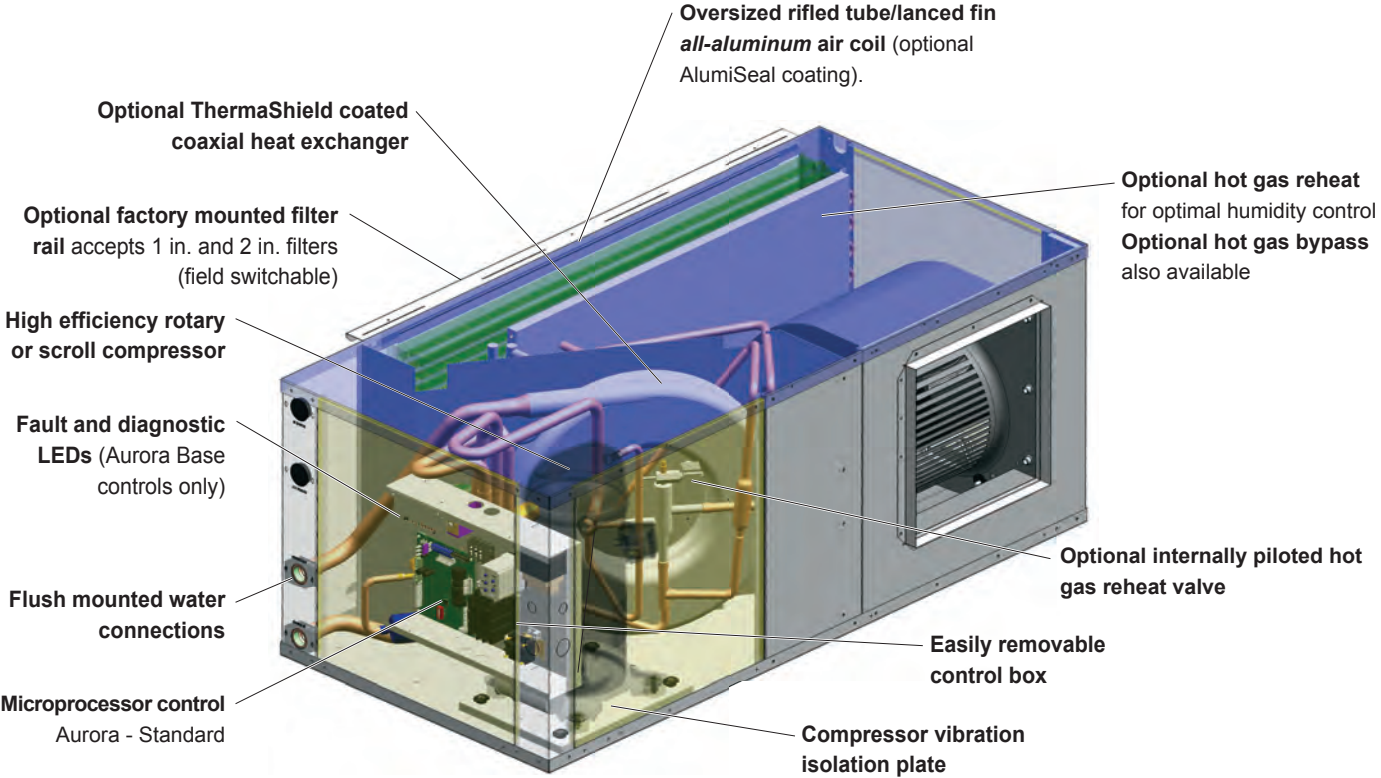

Four blower deck options are available. Factory or field conversion option of end or side discharge using switchable access panels and a factory only option of true left or right return air coil.

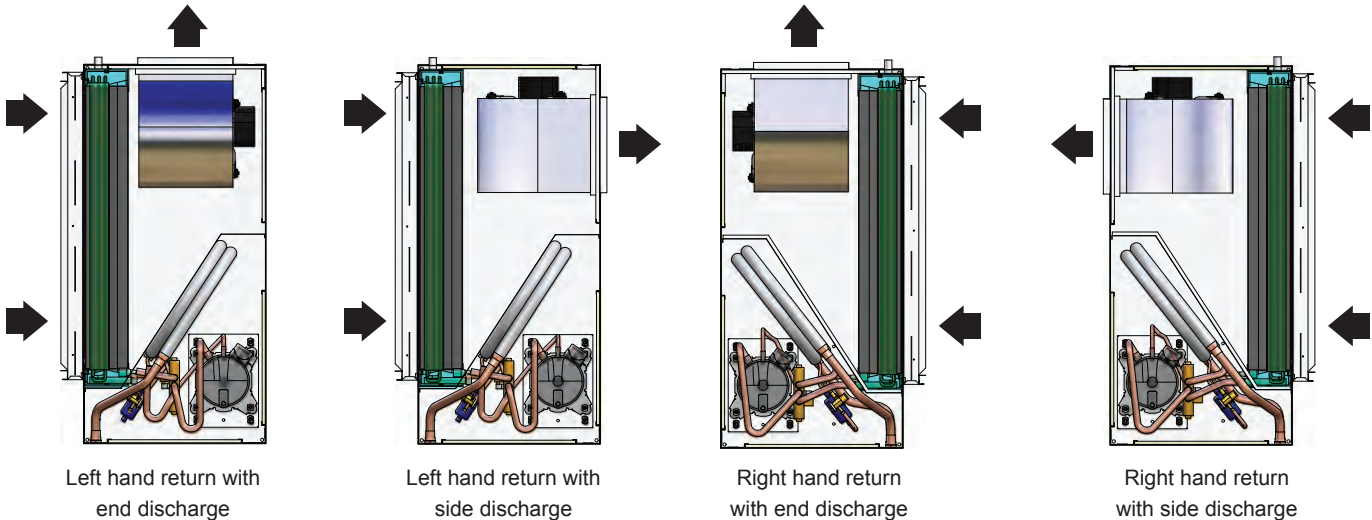

The LX Ultra Series cont.

Flexible Product with Several Standard Options

- Compact cabinet design, vertical and horizontal with true left and right return configurations
- Horizontal end and side discharge with vertical top discharge air configurations
- Capacities of 9,000 through 70,000 Btu/h
- All commercial voltages including 208-230/60/1, 265-277/60/1, 208-230/60/3, 460/60/3, and 575/60/3.
- Hot water generation (hot water generator - vertical only)
- IntelliStart soft starter
- 3 speed PSC, 5-speed ECM, or optional variable speed ECM blower motors (high static options available)
- FormiShield coated air coils
- Copper or cupronickel heat exchangers
- Extended range insulation option
- Super Quiet Sound Package, including multi-density compressor blanket
- Quiet rotary or scroll compressors in all models
- 2-dimension refrigerant piping vibration loops to isolate the compressor
- Double isolated compressor mounting utilizing eight durometer selected rubber grommets
- Heavy gauge cabinet and 4 vibration isolating hanger brackets
- Hot Gas Bypass and Reheat (015-072)
- Internally mounted water flow regulator and/or water solenoid valve for variable speed pumping systems
- Standard Aurora Base Control
- Phase guard with optional 'dial' disconnect
- Optional painted cabinet
- Polymer composite drain pan or stainless steel drain pan with optional secondary drain connection
- 1 in. MERV 4 or 2 in. MERV 13 filters

Other options are available by special request through your Commercial Sales rep.

High Efficiency

The LX Ultra Series is a high efficiency water source heat pump in a compact vertical and horizontal cabinet. The product features highly efficient and reliable single capacity rotary or scroll compressors mated with large blowers. These blowers are driven by efficient 3 speed PSC blower motors, 5-speed ECM blower motors, or highly efficient variable speed ECM blower motors.

Quiet Operation

All LX Ultra Series product incorporates several noise reduction technologies and is ARI 260 sound rated using third party sound testing. Room Noise Criteria Curves (NC Curve) may be calculated using data from the ARI 260 ratings giving the engineer total flexibility in assuring a quiet environment.

Super Quiet Option

An optional Super Quiet Sound Package is also available for a modest cost and features multi-density laminate lined compressor blanket designed to completely surround the compressor and suppress low frequency noise.



Indoor Air Quality (IAQ)

All LX Ultra Series features several IAQ benefits:

- Corrosion-free composite double-sloped drain pan to eliminate standing water and prevent bacterial growth
- A washable surface on insulation in all air handler compartments to allow cleanability and inhibit bacteria growth. Optional non-fibrous closed cell insulation is also available for more sensitive applications.
- Open filter rail comes standard for non-ducted return applications. Filter rail is field switchable from 1 in. to 2 in. [2.54 to 5.1 cm] for more filter options.
- Optional factory mounted, four sided, deluxe filter rack that is field switchable from 1 in. to 2 in. [2.54 to 5.1 cm] is available for ducted return applications.
- Standard supplied filter is a pleated MERV 4, 1 in. [2.54 cm]. An optional low static high efficiency 2 in. [5.1 cm] MERV 13, for LEED certification points, is also available.



The LX Ultra Series cont.

Aurora Base Control

The Aurora Base Control (ABC) System is a complete residential and commercial comfort system that brings all aspects of the HVAC system into one cohesive module network. Aurora uses the Modbus communication protocol to communicate between modules. Each module contains the logic to control all features that are connected to the module. The Aurora Base Control (ABC) has two Modbus channels. The first channel is configured as a master for connecting to devices such as a communicating thermostat, expansion board, or other slave devices. The second channel is configured as a slave for connecting the Aurora Interface Diagnostic (AID) Tool.

Control	General Description	Application	Display/Interface	Protocol
<p>Aurora Base Control</p> 	<p>The ABC microprocessor provides all the features necessary to operate today's standard WSHPs that utilize dual capacity compressors and variable speed ECM/5-speed ECM blower motors with hot gas reheat. This control can communicate to a handheld diagnostic tool to help the installing contractor or service technician with equipment setup and service. By utilizing Modbus RTU communication protocol, the ABC board can communicate with additional devices on the Aurora network.</p>	<p>Used for residential and commercial applications that use single or dual capacity compressors with PSC, 5-speed ECM, or variable speed ECM blower motors. This base control can also communicate to the AID Tool to display faults, inputs/outputs, and software revision. Commercial features such as hot gas reheat, slow opening water valve, and random start are also capable with the ABC board.</p>	<p>Optional AID Tool can be used for field service.</p>	<p>Standalone</p>

The LX Ultra Series cont.

Internally Mounted Solenoid Valve Option

When variable speed circulating pump systems are designed, low pressure drop (high Cv) solenoid valves are specified at each unit to vary the pump according to flow required. It is important that these valves be low pressure drop to avoid unwanted pump watts. This option factory installs this valve inside the unit.

Secondary Drain Connection Option

Some local building authority's interpretation of codes require more condensate overflow protection than standard microprocessor based condensate sensors offer. In these areas a full secondary drain pan might be required causing both increased cost and unit service access issues. In many of these cases a secondary drain connection option can be added to the unit to pass this local interpretation of condensate drain redundancy. This option adds a second PVC drain connection to the drain pan at a higher level.

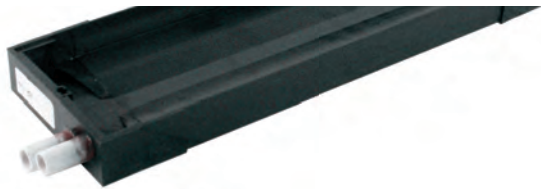

Hot Gas Bypass/Reheat

The hot gas bypass option is designed to limit the minimum evaporating pressure in the cooling mode to prevent the air coil from icing. Hot gas reheat option provides consistent comfort by removing moisture from the air without over cooling the space. These options are available together or standalone.

Phase Guard Monitor

Factory mounted phase guard device is available to protect the compressor against loss of phase and reverse rotation.

Electrical Disconnect

An optional factory mounted, internally wired disconnect is available to avoid scheduling problems with the electrical contractor. Other features include:

- Non-fused, 'dial' type switch with "on/off" position
- Compact design
- "Lockout/Tagout" feature to keep the unit "off" during service



Factory Quality

- All refrigerant brazing is performed in a nitrogen environment.
- Computer controlled deep vacuum and refrigerant charging system.
- All joints are leak detected for maximum leak rate of less than 1/4 oz. per year.
- Computer bar code equipped assembly line ensures all components are correct.
- All units are computer run-tested with water to verify both function and performance.

Inside the LX Ultra Series

Refrigerant

LX Ultra products all feature zero ozone depletion and low global warming potential refrigerant R-410A.

Cabinet

All units are constructed of corrosion resistant galvanized sheet metal with optional white polyester powder coat paint rated for more than 1,000 hours of salt spray. One large lift-out access panel provides access to the compressor and air handler section to allow servicing of blower motor, blower, and drain pan. Refrigerant circuit is designed to allow primary serviceability from the front. Seven (7) horizontal and seven (7) vertical cabinets are provided for application flexibility. The blower motor and blower can be

completely serviced or replaced without removal of the unit. Service of the blower and blower motor is made easier via the removable orifice ring on the housing.

Flexible configurations include four (4) blower deck options for horizontals and a true left and right return on both horizontal and vertical.

Filter Rack

All units come standard with an open filter rail, for use in open return applications, or an optional deluxe filter rack/duct collar for use with ducted returns. Both filter options are field switchable between 1 in. [2.54 cm] and 2 in. [5.1 cm] thick filters for filter

Inside the LX Ultra Series cont.

flexibility. A MERV 4, 1 in. [2.54 cm] is standard with an optional 2 in. [5.1 cm] MERV 13 for LEED certification points and high efficiency filtration.



Electrical Box

Unit controls feature quick connect wiring harnesses for easy servicing. Separate knockouts for low voltage and two sides of the electrical corner post for easy access to the control box. Large transformer (75VA with ABC with reheat and 50VA with ABC without reheat) assures adequate controls power for accessories.

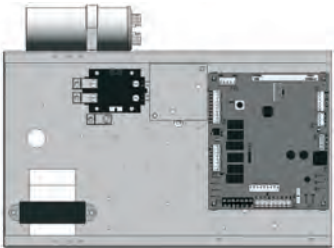

Water Connections

Flush mount FPT water connection fittings allow one wrench leak-free connections and do not require a backup wrench.



Horizontal Hanger Kits

Each horizontal unit includes a hanger kit to meet seismic specification requirements while still allowing filter access.

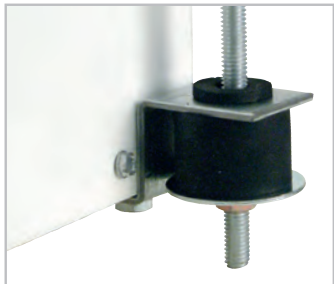

Drain Pan

All condensate connections are PVC glue for economical corrosion free connections. Bacteria resistant composite drain pan is sloped to promote complete drainage and will never rust or corrode. Complete drainage helps to inhibit bacterial or microbial growth. Vertical units

feature an internally trapped condensate line using clear PVC hose for easy inspection and reduced installation cost. Optional factory installed stainless steel drain pans are also available.



Compressors

High efficiency R-410A rotary or scroll compressors are used on every model. Rotary or scrolls provide both the highest efficiency available and great reliability. Single speed scroll models are available in commercial voltages.



Compressor Dual Isolation Mounting

Double isolated compressor mounting utilizing eight durometer selected rubber grommets. This isolation greatly reduces the primary noise frequency range of 100-300 Hz.



Air Handler Insulation

Washable air handler insulation surface provides cleanability to further enhance IAQ.

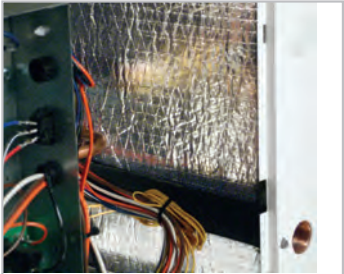

Thermostatic Expansion Valve

All LX Ultra Series models utilize a balanced port bidirectional thermostatic expansion valve (TXV) for refrigerant metering. This allows precise refrigerant flow in a wide range of entering water variation (20 to 120°F [-7 to 49°C]) found in geothermal systems. The TXV is located in the compressor compartment for easy access.



Inside the LX Ultra Series cont.

Water-to-Refrigerant Coaxial Heat Exchanger Coil

Large oversized coaxial refrigerant to water heat exchangers provide unparalleled efficiency. The coaxes are designed for low pressure drop and low flow rates. All coaxes are pressure rated to 450 psi water side and 600 psi on the refrigerant side. Optional ThermaShield coating is available on the water-to-refrigerant heat exchanger to prevent condensation in low temperature loop operation.



Service Connections and Serviceability

Two Schrader service ports are provided in every unit. The suction side and discharge side ports are for field charging and servicing access. All valves are 7/16 in. SAE connections. All water and electrical connections are made from the front of the unit. Unit is designed for front access serviceability.



4-Way Reversing Valve

LX Ultra units feature a reliable all-brass pilot operated refrigerant reversing valve. The reversing valve operation is limited to change of mode by the control to enhance reliability.

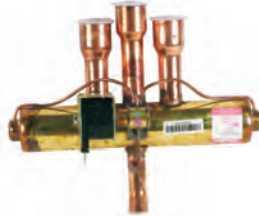

All-Aluminum Air Coil

All models in the LX Ultra line ship standard with all-aluminum air coils. These air coils are constructed of lanced fin and rifled tube aluminum that is not susceptible to formicary corrosion. For additional condensate runoff and meeting project specifications, an optional AlumiSeal e-coating is available.



Blower Motor and Housing

High efficiency low rpm galvanized direct drive blower featuring 3 speed permanently split capacitor (PSC) motor, 5-speed ECM motor, and optional variable speed ECM blower motor. The variable speed ECM motor is controlled directly through the unit's Aurora Base Control. The lower rpm blower also reduces air noise. All PSC and 5-speed ECM motors have speed selection terminal strip on

the motor for easy speed change. All motors are vibration isolated to reduce noise. High static options are available in some models for both PSC and variable speed ECM motor versions. Horizontal units can be field converted from end to side discharge as well.

NOTE: 460V 5-speed ECM blower motor does not require a neutral wire.

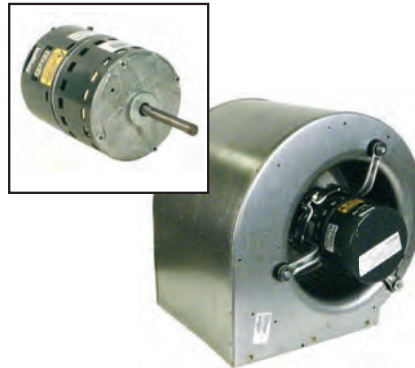

5-Speed ECM Constant Torque Motors

The 5-speed ECM is a 'Constant Torque' ECM motor and delivers air flow similar to a PSC but operates as efficiently as a variable speed ECM motor. Because it's an ECM motor, the 5-speed ECM can ramp slowly up or down like the variable speed ECM motor. There are 5 possible speed taps available on the 5-speed ECM motor with #1 being the lowest airflow and #5 being the highest airflow. These speed selections are preset at the time of manufacture and are easily changed in the field if necessary.

5-Speed ECM Benefits:

- High efficiency
- Soft start
- 5 speeds with up to 4 speeds on-line
- Built in logic allows air flow to change with G, Y1, Y2 and W signals
- Super efficient low airflow continuous blower setting (G)

IntelliStart™

The optional IntelliStart single phase soft starter will reduce the normal start current (LRA) by 60%. This allows the heat pump to go off-grid. Using IntelliStart also provides a substantial reduction in light flicker, reduces start-up noise, and improves the compressor's start behavior.

IntelliStart is available in a field retrofit kit or as a factory installed option for all LX Ultra Series units.



Controls - Aurora Base Controls

Aurora 'Base' Control

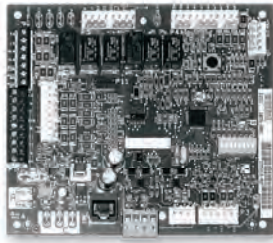

NOTE: Refer to the Aurora Base Control Application and Troubleshooting Guide and the Instruction Guide: Aurora Interface and Diagnostics (AID) Tool for additional information.

Control Features

Software ABC Standard Version 2.0

Single or Dual Capacity Compressors

Either single or dual capacity compressors can be operated.

ECM Blower Motor Option

An ECM blower motor can be driven directly using the onboard PWM output. Four blower speeds are available based upon the G, Y1, Y2, and W input signals to the board. The blower speeds can be changed either by the ECM manual configurations mode method or by using the Aurora AID Tool directly. All four blower speeds can be set to the same speed if desired.

5-Speed ECM Blower Motor Option

A 5-Speed ECM blower motor will be driven directly using the thermostat connections. Any of the G, Y1, or Y2/W signals can drive any of the 5 available pre-programmed blower speeds on the motor.

Other Control Features

- Random start at power up
- Anti-short cycle protection
- High and low pressure cutouts
- Loss of charge
- Water coil freeze detection
- Air coil freeze detection
- Over/under voltage protection
- Condensate overflow sensor
- Load shed
- Dehumidification (where applicable)
- Emergency shutdown
- Hot gas reheat operation (where applicable)
- Diagnostic LED
- Test mode push button switch
- Two auxiliary electric heat outputs
- Alarm output
- Accessory output with N.O. and N.C.
- Modbus communication (master)
- Modbus communication (slave)

Field Selectable Options via Hardware

DIP Switch (SW1) – Test/Configuration Button (See SW1 Operation Table)

Test Mode

The control is placed in the test mode by holding the push button switch SW1 for 2 - 5 seconds. In test mode most of the control timings will be shortened by a factor of sixteen (16). LED3 (green) will flash at 1 second on and 1 second off. Additionally, when entering test mode LED1 (red) will flash the last lockout one time. Test mode will automatically time out after 30 minutes. Test mode can be exited by pressing and holding the SW1 button for 2 to 5 seconds or by cycling the power. **NOTE:** Test mode will automatically be exited after 30 minutes.

ECM Configuration Mode

The control is placed in the ECM configuration mode by holding the pushbutton switch SW1 for 5 to 10 seconds, the high, low, and "G" ECM speeds can be selected by following the LED display lights. LED2 (yellow) will fast flash when entering the ECM configuration. When setting "G" speed LED3 (green) will be continuously lit, for low speed LED1 (red) will be continuously lit, and for high speed both LED3 (green) and LED1 (red) will be continuously lit. During the ECM configuration mode LED2 (yellow) will flash each of the 12 possible blower speeds 3 times. When the desired speed is flashed press SW1, LED2 will fast flash until SW1 is released. "G" speed has now been selected. Next select low speed, and high speed blower selections following the same process above. After third selection has been made, the control will exit the ECM configuration mode. Aux fan speed will remain at default or current setting and requires the AID Tool for adjustment.

Reset Configuration Mode

The control is placed in reset configuration mode by holding the push button switch SW1 for 50 to 60 seconds. This will reset all configuration settings and the EEPROM back to the factory default settings. LED3 (green) will turn off when entering reset configuration mode. Once LED3 (green) turns off, release SW1 and the control will reset.

DIP Switch (SW2)

- SW2-1** FP1 Selection – Low water coil temperature limit setting for freeze detection. On = 30°F; Off = 15°F.
- SW2-2** FP2 Selection – On = 30°F; Off = N/A
- SW2-3** RV – O/B - thermostat type. Heat pump thermostats with "O" output in cooling or "B" output in Heating can be selected. On = O; Off = B.
- SW2-4** Access Relay Operation (P2)
and 2-5

Access Relay Operation	SW2-4	SW2-5
Cycle with Blower	ON	ON
Cycle with Compressor	OFF	OFF
Water Valve Slow Opening	ON	OFF
Cycle with Comm. T-stat Hum Cmd	OFF	ON

Controls - Aurora Base Controls cont.

Cycle with Blower - The accessory relay will cycle with the blower output.

Cycle with Compressor - The accessory relay will cycle with the compressor output.

Water Valve Slow Opening - The accessory relay will cycle and delay both the blower and compressor output for 90 seconds.

- SW2-6** CC Operation – selection of single or dual capacity compressor. On = Single Stage; Off = Dual Capacity
- SW2-7** Lockout and Alarm Outputs (P2) – selection of a continuous or pulsed output for both the LO and ALM Outputs. On = Continuous; Off = Pulsed
- SW2-8** Future Use

Alarm Jumper Clip Selection

From the factory, ALM is connected to 24 VAC via JW2. By cutting JW2, ALM becomes a dry contact connected to ALG.

ECM Blower Speeds

The blower speeds can be changed either by using the ECM manual configurations mode method or by using the Aurora AID Tool directly (see Instruction Guide: Aurora Interface and Diagnostics (AID) Tool topic).

Field Selectable Options via Software

(Selectable via the Aurora AID Tool)

ECM Blower Speeds

An ECM blower motor can be driven directly using the onboard PWM output. Four blower speeds are available, based upon the “G”, Y1 (low), Y2 (high), and Aux input signals to the board. The blower speeds can be changed either by the ECM manual configurations mode method (see ECM Configuration Mode topic) or by using the Aurora AID Tool directly. All four blower speeds can be set to the same speed if desired. Aux blower speed will remain at default or current setting and requires the AID Tool for adjustment.

Safety Features

The following safety features are provided to protect the compressor, heat exchangers, wiring and other components from damage caused by operation outside of design conditions.

Fuse – a 3 amp automotive type plug-in fuse provides protection against short circuit or overload conditions.

Anti-Short Cycle Protection – 4 minute anti-short cycle protection for the compressor.

Random Start – 5 to 80 second random start upon power up.

Fault Retry – in the fault condition, the control will stage off the outputs and then “try again” to satisfy the thermostat Y input call. Once the thermostat input calls are satisfied, the control will continue on as if no fault occurred. If 3 consecutive faults occur without satisfying the thermostat Y input call, then the control will go to Lockout mode.

Lockout – when locked out, the blower will operate continuously in “G” speed, and PSC blower motor output will remain on. The Alarm output (ALM) and Lockout output (L) will be turned on. The fault type identification display LED1 (Red) shall flash the fault code. To reset lockout conditions with SW2-8 On, thermostat inputs “Y1”, “Y2”, and “W” must be removed for at least 3 seconds. To reset lockout conditions with SW2-8 Off, thermostat inputs “Y1”, “Y2”, “W”, and “DH” must be removed for at least 3 seconds. Lockout may also be reset by turning power off for at least 30 seconds or by enabling the emergency shutdown input for at least 3 seconds.

Lockout With Emergency Heat - if the control is locked out in the heating mode, and a Y2 or W input is received, the control will operate in the emergency heat mode while the compressor is locked out. The first emergency heat output will be energized 10 seconds after the W input is received, and the blower will shift to high speed. If the control remains locked out, and the W input is present, additional stage of emergency heat will stage on after 2 minutes. When the W input is removed, all of the emergency heat outputs will turn off, and the ECM blower will shift to “G” speed and PSC blower motor output will remain on.

High Pressure – fault is recognized when the Normally Closed High Pressure Switch, P4-9/10 opens, no matter how momentarily. The High Pressure Switch is electrically in series with the Compressor Contactor and serves as a hard-wired limit switch if an overpressure condition should occur.

Low Pressure - fault is recognized when the Normally Closed Low Pressure Switch, P4-7/8 is continuously open for 30 seconds. Closure of the LPS any time during the 30 second recognition time restarts the 30 second continuous open requirement. A continuously open LPS shall not be recognized during the 2 minute startup bypass time.

Loss of Charge – fault is recognized when the Normally Closed Low Pressure Switch, P4-7/8 is open prior to the compressor starting.

Condensate Overflow - fault is recognized when the impedance between this line and 24 VAC common or chassis ground drops below 100K ohms for 30 seconds continuously.

Freeze Detection (Coax) - set points shall be either 30°F or 15°F. When the thermistor temperature drops below the selected set point, the control shall begin counting down the 30 seconds delay. If the thermistor value rises above the selected set point, then the count should reset. The resistance value must remain below the selected set point for the entire length of the appropriate delay to be recognized as a fault. This fault will be ignored for the initial 2 minutes of the compressor run time.

Freeze Detection (Air Coil) - uses the FP2 input to protect against ice formation on the air coil. The FP2 input will operate exactly like FP1 except that the set point is 30 degrees and is not field adjustable.

Controls - Aurora Base Controls cont.

Over/Under Voltage Shutdown - An over/under voltage condition exists when the control voltage is outside the range of 18 VAC to 30 VAC. If the over/under voltage shutdown lasts for 15 minutes, the lockout and alarm relay will be energized. Over/under voltage shutdown is self-resetting in that if the voltage comes back within range of 18 VAC to 30 VAC for at least 0.5 seconds, then normal operation is restored.

Operation Description

Power Up - The unit will not operate until all the inputs and safety controls are checked for normal conditions. The unit has a 5 to 80 second random start delay at power up. Then the compressor has a 4 minute anti-short cycle delay after the random start delay.

Standby In standby mode, Y1, Y2, W, DH, and G are not active. Input O may be active. The blower and compressor will be off.

Heating Operation

Heating, 1st Stage (Y1) - The blower is started on "G" speed immediately and the compressor is energized 10 seconds after the Y1 input is received. The ECM blower motor is switched to low speed 15 seconds after the Y1 input.

Heating, 2nd Stage (Y1, Y2) - The compressor will be staged to full capacity 20 seconds after Y2 input is received. The ECM blower will shift to high speed 15 seconds after the Y2 input is received.

Heating, 3rd Stage (Y1, Y2, W) - The hot water pump is de-energized and the first stage of electric heat is energized 10 seconds after the W command is received. If the demand continues the second stage of electric heat will be energized after 5 minutes.

Emergency Heat (W) - The blower will be started on "G" speed, 10 seconds later the first stage of electric heat will be turned on. 5 seconds after the first stage of electric heat is energized the blower will shift to Aux speed. If the emergency heat demand is not satisfied after 2 minutes the second electric heat stage will be energized.

Blower (G) - The blower will start immediately upon receiving a thermostat G command. If there are no other commands from the thermostat the ECM will run on "G" speed until the G command is removed. Regardless of blower input (G) from the thermostat, the blower will remain on for 30 seconds at the end of each heating cycle.

Cooling Operation

In all cooling operations, the reversing valve directly tracks the O input. Thus, anytime the O input is present, the reversing valve will be energized.

Cooling, 1st Stage (Y1, O) - The blower is started on "G" speed immediately and the compressor is energized 10 seconds after the Y1 input is received. The ECM blower motor is switched to low speed 15 seconds after the Y1 input.

Cooling, 2nd Stage (Y1, Y2, O) - The compressor will be staged to full capacity 20 seconds after Y2 input is received. The ECM blower will shift to high speed 15 seconds after the Y2 input is received.

Blower (G) - The blower will start immediately upon receiving a thermostat G command. If there are no other commands from the thermostat the ECM will run on "G" speed until the G command is removed. Regardless of blower input (G) from the thermostat, the blower will remain on for 30 seconds at the end of each heating, cooling, and emergency heat cycle.

Dehumidification (Y1, O, DH or Y1, Y2, O, DH) - When a DH command is received from the thermostat during a compressor call for cooling the ECM blower speed will be reduced by 15% to increase dehumidification.

Emergency Shutdown - Four (4) seconds after a valid ES input, P2-7 is present, all control outputs will be turned off and remain off until the emergency shutdown input is no longer present. The first time that the compressor is started after the control exits the emergency shutdown mode, there will be an anti-short cycle delay followed by a random start delay. Input must be tied to common to activate.

Continuous Blower Operation - The blower output will be energized any time the control has a G input present, unless the control has an emergency shutdown input present. The blower output will be turned off when G input is removed.

Load Shed - The LS input disables all outputs with the exception of the blower output. When the LS input has been cleared, the anti-short cycle timer and random start timer will be initiated. Input must be tied to common to activate.

Controls - Aurora Base Controls cont.

Aurora 'Base' Control LED Displays

These three LEDs display the status, configuration, and fault codes for the control. These can also be read in plain English via the Aurora AID Tool.

Status LED (LED3, Green)

Description of Operation	Fault LED, Green
Normal Mode	ON
Control is Non-functional	OFF
Test Mode	Slow Flash
Lockout Active	Fast Flash
Dehumidification Mode	Flash Code 2
(Future Use)	Flash Code 3
(Future Use)	Flash Code 4
Load Shed	Flash Code 5
ESD	Flash Code 6
(Future Use)	Flash Code 7

Configuration LED (LED2, Yellow)

Description of Operation	Configuration LED, Yellow
No Software Overwritten	Flashing ECM Setting
DIP Switch was Overwritten	Slow Flash
ECM Configuration Mode	Fast Flash

Fault LED (LED1, Red)

Red Fault LED		LED Flash Code*	Lockout	Reset/Remove
ABC Basic Faults	Normal - No Faults	OFF	-	
	Fault - Input	1	No	Auto
	Fault - High Pressure	2	Yes	Hard or Soft
	Fault - Low Pressure	3	Yes	Hard or Soft
	Fault - Freeze Detection FP2	4	Yes	Hard or Soft
	Fault - Freeze Detection FP1	5	Yes	Hard or Soft
	Fault - Condensate Overflow	7	Yes	Hard or Soft
	Fault - Over/Under Voltage	8	No	Auto
	Fault - FP1 & FP2 Sensor Error	11	Yes	Hard or Soft

NOTE: All codes >11 use long flash for tens digit and short flash for the ones digit. 20, 30, 40, 50, etc. are skipped.

Aurora Interface and Diagnostics (AID) Tool

The Aurora Interface and Diagnostics (AID) Tool is a device that is a member of the Aurora network. The AID Tool is used to troubleshoot equipment which uses the Aurora control via Modbus RTU communication. The AID Tool provides diagnostics, fault management, ECM setup, and system configuration capabilities to the Aurora family of controls. An AID Tool is recommended, although not required, for ECM airflow settings. The AID Tool simply plugs into the exterior of the cabinet in the AID Tool port.



ABC Control Board Layout

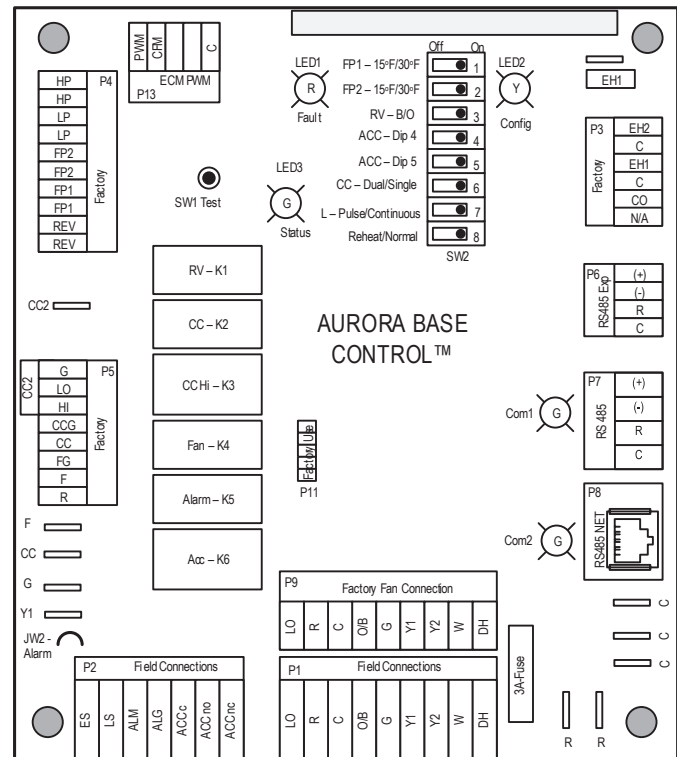

Hot Gas Reheat/Hot Gas Bypass

Hot Gas Reheat Description

The refrigerant flows in normal heat pump path in heating and cooling mode. During the Reheat mode, the operation begins with superheated vapor leaving the compressor going through the reheat valve to the reheat air coil. In the reheat coil the high temperature high pressure gas reheats the air exiting the unit to near neutral. Next, the refrigerant exits the reheat coil and passes through a check valve, which is used to prevent refrigerant flow into the reheat coil during normal heating and cooling operation. The refrigerant passes through the check valve and is then diverted to the coaxial heat exchanger by the four way reversing valve. The hot gas enters the coaxial heat exchanger which will condense the gas to a high pressure liquid due to heat being rejected to the loop fluid. The high pressure liquid leaves the coax and enters the inlet of the TXV. After passing through the TXV the low pressure mixture of liquid/vapor refrigerant expands in the air coil evaporating into a low pressure low temperature gas and moves back through the reversing valve and into the compressor suction. The cycle then starts again by compressing the low

pressure low temperature gas into a superheated vapor. A small copper bleed line is located on the reheat/reclaim valve to allow refrigerant that has migrated to the reheat coil to escape.

Hot Gas Bypass Description

The hot gas bypass (HGB) option is designed to limit the minimum evaporating pressure in the cooling mode to prevent the air coil from icing. The HGB valve senses pressure at the outlet of the evaporator by an external equalizer. If the evaporator pressure decreases to 115 psig the HGB valve will begin to open and bypass hot discharge gas into the inlet of the evaporator. The valve will continue to open as needed until it reaches its maximum capacity. Upon a rise of suction pressure, the valve will begin to close back off and normal cooling operation will resume.

Hot Gas Reheat Dehumidification Overview

Hot Gas Reheat Dehumidification Overview Dehumidification - The Need for Reheat

With tighter construction and more and more ventilation air being introduced into buildings, there is more need now than ever for proper humidity control. Ensuring dehumidification can provide consistent employee comfort, a reduction in mold liability, a reduction in cooling costs. Reduced humidity also provides an improvement in indoor air quality (IAQ) thru lower humidity levels which can reduce allergen levels, inhibit mold and bacterial growth, and provide an improved computer environment. ASHRAE 90.1 speaks of an acceptable humidity range in all commercial buildings.

Typical Reheat Applications

Reheat can be used wherever moisture is a problem. Schools, high latent auditorium and theaters, makeup air units*, and computer rooms are typical applications. Although reheat equipped water source heat pumps (wshp's) can condition limited amounts of outdoor air, the percentage of this outdoor air should never exceed 50% of the return air to the unit limiting the mixed return air temperature to a minimum of 50°F. When cold entering air conditions are anticipated, hot gas bypass option should be considered to prevent air coil freeze up.

*A dedicated outdoor air system (DOAS) should be investigated for 100% outdoor air applications.

The Design of Reheat Equipment

Hot gas reheat can help maintain specific humidity levels and neutral air in a building. ASHRAE recommends a relative humidity range of 30-60% with levels greater than 65% making mold growth a possibility. The dehumidification relative humidity set points of 57% (on) and 52% (off) are recommended. During reheat the leaving air temperature (LAT) will approximate neutral air. The included chart (Leaving Air Temperature vs. Entering Water and Air Conditions Chart) shows the LAT vs entering water temperature (EWT) to the unit at differing entering air conditions. At 86-90°F EWT the unit will provide nearly neutral air.

Moisture Removal Capacity

The amount of moisture removal may be calculated by subtracting the sensible cooling capacity from the total cooling capacity in the equipment performance data of the specifications catalog or submittal data. An example is shown below:

Model YG*048, 1275 cfm, 12 gpm, 90°F EWT

$$TC - SC = LC$$

$$46.5 - 34.6 \text{ MBtu/h} = 11.9 \text{ MBtu/h}$$

Where TC = total cooling capacity, SC=sensible capacity, LC=latent capacity

Leaving Air Temperature vs. Entering Water and Air Conditions Chart

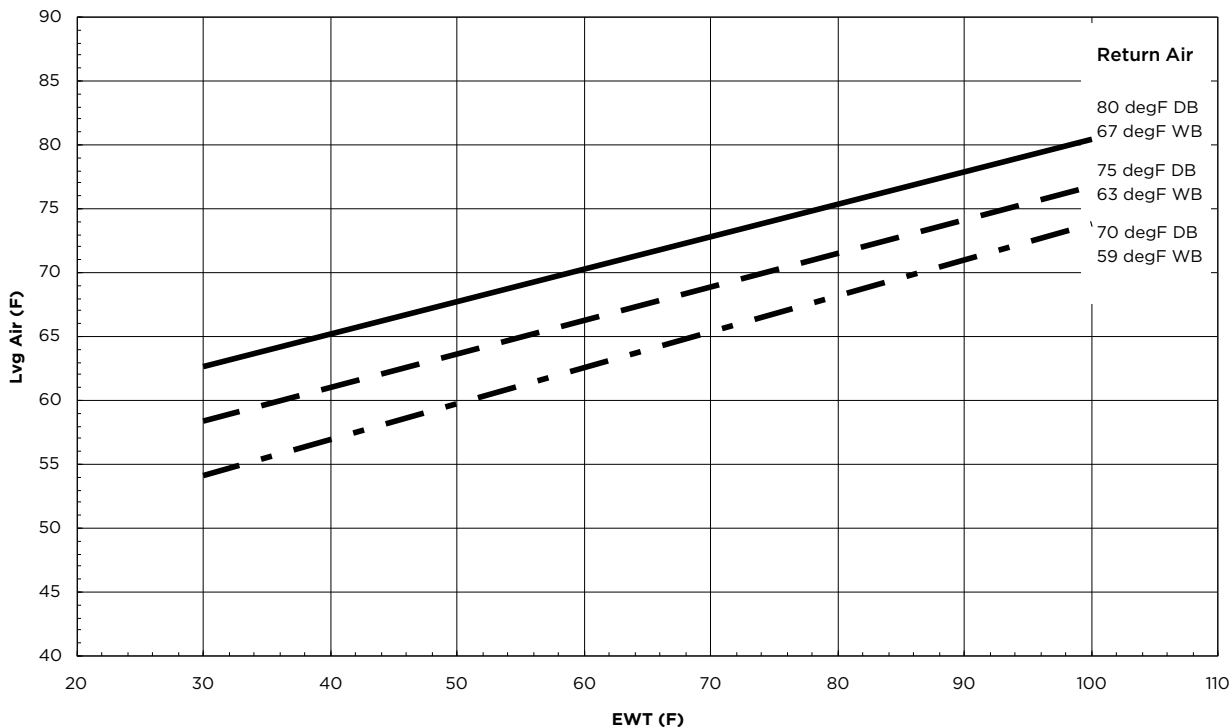

Hot Gas Reheat Dehumidification Overview cont.

Hot Gas Reheat Dehumidification Overview cont.

Btu/hr may be converted to lbs/hr or grains per hour as shown in the equations below.

$$11,900 \text{ Btu/h} / 1,069 \text{ Btu/lb of water vapor at } 80/67 \text{ DB/WB}^\circ\text{F} = 11.13 \text{ lbs/hr}$$

$$11.13 \text{ lbs/hr} \times 7,000 \text{ grains/lb} = 77,910 \text{ grains/hr}$$

External Static Pressure Adjustment

With a reheat coil option installed an adjustment for external static pressure (ESP) needs to be made. The following table will show the reduction in ESP for any model relating coil air velocity and ESP.

ESP vs. Coil Velocity Table

Coil Velocity (fpm)	250	300	350	400
ESP Increase (in. wg.)	0.10	0.14	0.17	0.20

Variable speed ECM models will generally compensate up to their maximum ESP of 0.5 in. wg. for 1/2 hp and 0.75 in. wg. for 1 hp.

Model YG048, 1500 cfm,

$$H \times W = SA$$

$$20 \times 40 = 800 \text{ in.}^2 = 5.56 \text{ ft.}^2$$

Where H=fin height of air coil, W=fin length of air coil, SA=fin surface area

Adjustment must be made for dehumidification mode, 85% of cfm,

$$1500 \times 0.85 = 1,275 \text{ cfm}$$

Calculate air velocity, fpm, cfm / SA

$$1,275 \text{ cfm} / 5.56 \text{ ft.}^2 = 229 \text{ fpm}$$

Refer to the ESP vs. Coil Velocity Table and look up the fpm to find ESP increase. If air velocity is below 250 cfm assume 0.10 increase in ESP. Interpolation of data within the table is permitted.

Hot Gas Bypass with Hot Gas Reheat Layout

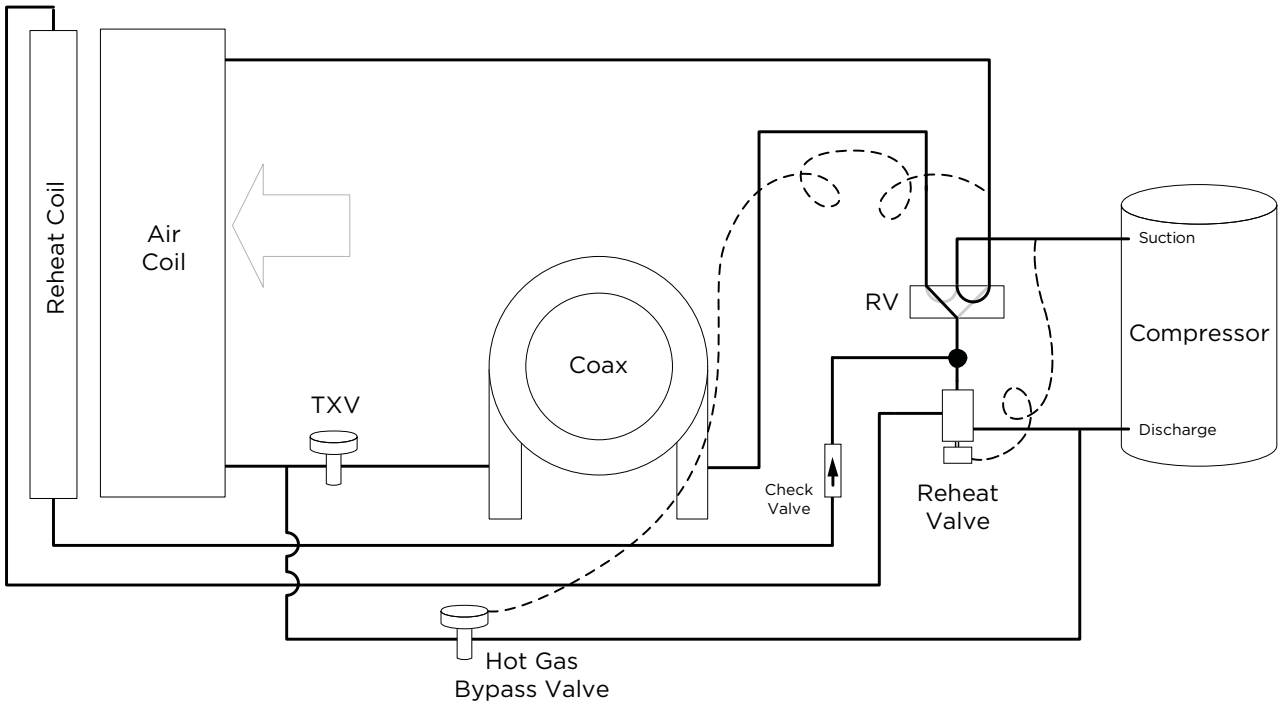

Hot Gas Reheat - Controls

The reheat option is available with the Aurora or control. The following control scheme is available:

Room wall dehumidistat

An optional room wall dehumidistat that controls the reheat mode thru a 24VAC 'Hum' input (On or Off). Setpoint and deadband is determined by the dehumidistat.

The unit will cycle thru a 'flush cycle' to purge refrigerant and oil from the idle heat exchanger once every 24 hours when in cooling mode. The control will provide an option to set back reheat to an adjustable unoccupied humidity set point during unoccupied time periods. This option is factory set to "OFF" so reheat will control to one set point at all times. If set back is required during unoccupied times the option must be set to "ON" in the field by the building automation system or a user interface. The dehumidification set back will only work when using a duct humidity sensor or room wall humidity sensor.

Mode of Operation

Please refer to the refrigeration circuit diagram (Hot Gas Reheat - Refrigerant section) and the hot gas reheat wiring schematic.

Heating Mode Operation

Upon a call for heating (Y), blower relay is energized immediately, and the compressor contactor will be energized after a 90 second delay.

Cooling Mode Operation

Upon a call for cooling (Y, O), blower relay and reversing valve coil are energized immediately, and the compressor contactor is energized after a 90 second delay. If there is a call from the de-humidistat or the internal control logic see the humidity sensor has reached set point the blower cfm will be reduced by 15% to increase the unit's latent capacity.

Dehumidification Mode Operation

Upon a call for dehumidification, the blower relay and reversing valve coil are energized immediately, and the compressor contactor will energize after a 90 second delay. The reheat valve coil will energize once the compressor has been operational for 30 seconds.

If a call for space heating is received during reheat operation the compressor will shut down for 5 minutes and the unit will restart in the heating mode. Once the requirement for space heating has been satisfied the unit will shut down for 5 minutes and re-start in reheat mode.

If a call for space cooling is received during reheat operation the reheat valve coil will be disabled until the space cooling requirements have been satisfied. Once the space cooling requirements have been satisfied the reheat valve coil will be energized with out shutting down the compressor.

Dehumidification Set Point

(used only with a humidity sensor)

The factory default set point for dehumidification is 52% this is field adjustable from 30% to 60%. In addition there is a factory default differential of 5% field adjustable from 5% to 15%. The control will enable re-heat when the space humidity rises above the set point plus the differential. Depending upon the environmental conditions within the building and the operating parameters of the water source heat pump, the unit may not be capable of maintaining the lower control limit of 30% relative humidity over extended periods of time.

Reheat operation during periods of un-occupancy

This unoccupied set point is useful to reduce energy use in dehumidification. Many system designs greatly reduce or even eliminate fresh air makeup during the unoccupied hours and the need for reheat is lessened. The control logic contains an unoccupied set point that can be used for the unoccupied mode if desired. The factory default for the set point is 60% and is adjustable from 30% to 60%. The unoccupied setback must be enabled either through a building automation system or with a user interface. Factory default for unoccupied setback is off.

Space Humidity High and Low Alarm Limit

(building automation system only)

The control has a high and low alarm limit that can be enumerated over a building automation system. The factory default set point for these alarm limits is 0% for the low alarm and 100% for the high alarm limit. These limits can be adjusted through a building automation system. Caution should be used in selecting these limits so as not to cause nuisance alarms.

Application Notes

The Closed Loop Heat Pump Concept

The basic principle of a water source heat pump is the transfer of heat into water from the space during cooling, or the transfer of heat from water into the space during heating. Extremely high levels of energy efficiency are achieved as electricity is used only to move heat, not to produce it. Using a typical LX Ultra Series, one unit of electricity will move four to five units of heat.

When multiple water source heat pumps are combined on a common circulating loop, the ultimate in energy efficiency is created: The heat pump units on cooling mode are adding heat to the loop which the units in heating mode can absorb, thus removing heat from the area where cooling is needed, recovering and redistributing that heat for possible utilization elsewhere in the system. In modern commercial structures, this characteristic of heat recovery from core area heat generated by lighting, office equipment, computers, solar radiation, people or other sources, is an important factor in the high efficiency and low operating costs of closed source heat pump systems.

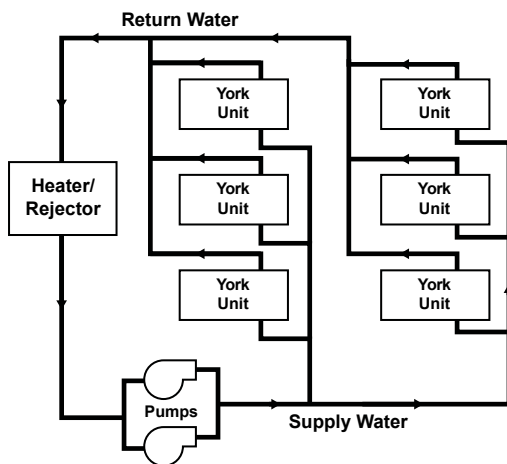

In the event that a building's net heating and cooling requirements create loop temperature extremes, LX Ultra Series units have the extended range capacity and versatility to maintain a comfortable environment for all building areas. Excess heat can be stored for later utilization or be added or removed in one of three ways; by ground-source heat exchanger loops: plate heat exchangers connected to other water sources, or conventional cooler/boiler configurations. Your sales representative has the expertise and computer software to assist in determining optimum system type for specific applications.

The Closed Loop Advantage

A properly applied water source heat pump system offers many advantages over other systems. First costs are low because units can be added to the loop on an "as needed basis"- perfect for speculative buildings. Installed costs are low since units are self-contained and can be located adjacent to the occupied space, requiring minimal ductwork. Maintenance can be done

on individual units without system shut-down. Conditions remain comfortable since each unit operates separately, allowing cooling in one area and heating in another. Tenant spaces can be finished and added as needed. Power billing to tenants is also convenient since each unit can be individually metered: each pays for what each uses. Nighttime and/or weekend uses of certain areas are possible without heating or cooling the entire facility. A decentralized system also means if one unit should fault, the rest of the system will continue to operate normally, as well as eliminating air cross-contamination problems and expensive high pressure duct systems requiring an inefficient electric resistance reheat mode.

The LX Ultra Series Approach

There are a number of proven choices in the type of LX Ultra Series system which would be best for any given application. Most often considered are:

Vertical - Closed Loop/Ground Source

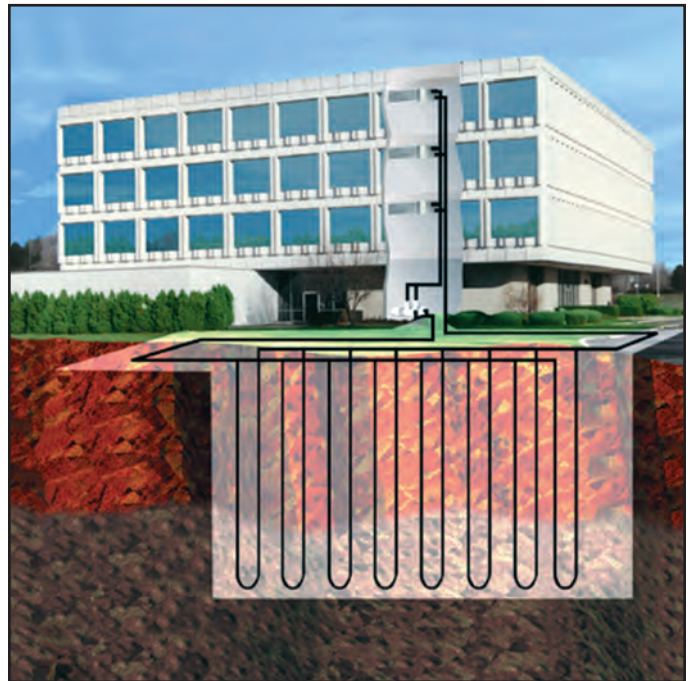

• **Closed Loop/Ground-Source Systems** utilize the stable temperatures of the earth to maintain proper water source temperatures (via vertical or horizontal closed loop heat exchangers) for LX Ultra Series extended range heat pump system. Sizes range from a single unit through many hundreds of units. When net cooling requirements cause closed loop water temperatures to rise, heat is dissipated into the cooler earth through buried high strength plastic pipe "heat exchangers." Conversely if net space heating demands cause loop heat absorption beyond that heat recovered from building core areas, the loop temperature will fall causing heat to be extracted from the earth. Due to the extended loop temperatures, AHRI/ISO 13256-1 Ground Loop Heat Pumps are required for this application.

Application Notes cont.

Because auxiliary equipment such as a fossil fuel boiler and cooling tower are not required to maintain the loop temperature, operating and maintenance costs are very low.

Ground-source systems are most applicable in residential and light commercial buildings where both heating and cooling are desired, and on larger envelope dominated structures where core heat recovery will not meet overall heating loads. Both vertical and horizontally installed closed-loops can be used. The land space required for the "heat exchangers" is 100-250 sq. ft./ton on vertical (drilled) installations and 750-1500 sq. ft./ton for horizontal (trenched) installations. Closed loop heat exchangers can be located under parking areas or even under the building itself.

On large multi-unit systems, sizing the closed loop heat exchanger to meet only the net heating loads and assisting cooling loads with a closed circuit cooling tower may be the most cost effective choice.

Surface Water - Closed Loop/Ground Source

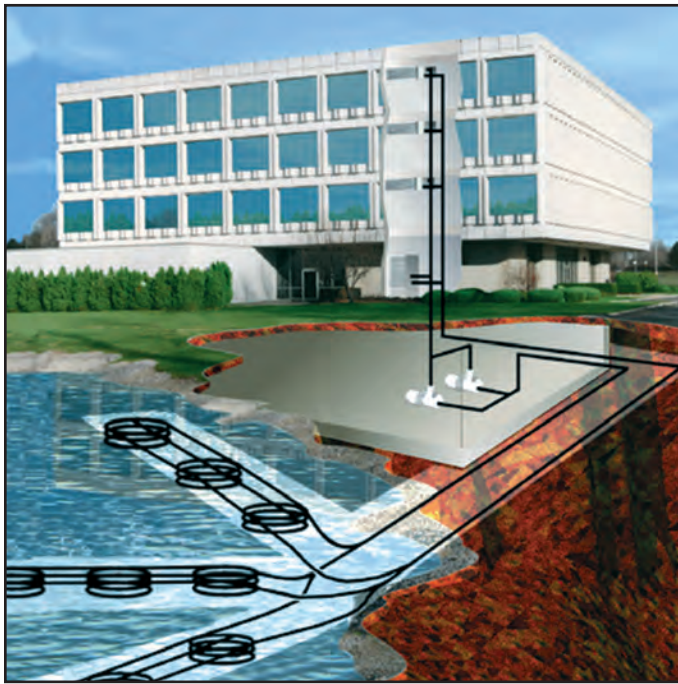

• **Closed Loop/Ground-Source Surface Water Systems** also utilize the stable temperatures of Surface Water to maintain proper water source temperatures for LX Ultra Series extended range heat pump systems. These systems have all of the advantages of horizontal and vertical closed loop systems. Due to the extended loop temperatures, AHRI/ISO 13256-1 Ground Water or Ground Loop Heat Pumps are required for this application.

In cooling dominated structures, the ground-source surface water systems can be very cost effective especially where local building codes require water retention ponds for short term storage of

surface run-off. Sizing requirements for the surface water is a minimum of 500 sq. ft./ton of surface area at a minimum depth of 8 feet. Your sales representative should be contacted when designs for heating dominated structures are required.

Plate Heat Exchanger - Closed Loop/Ground Water

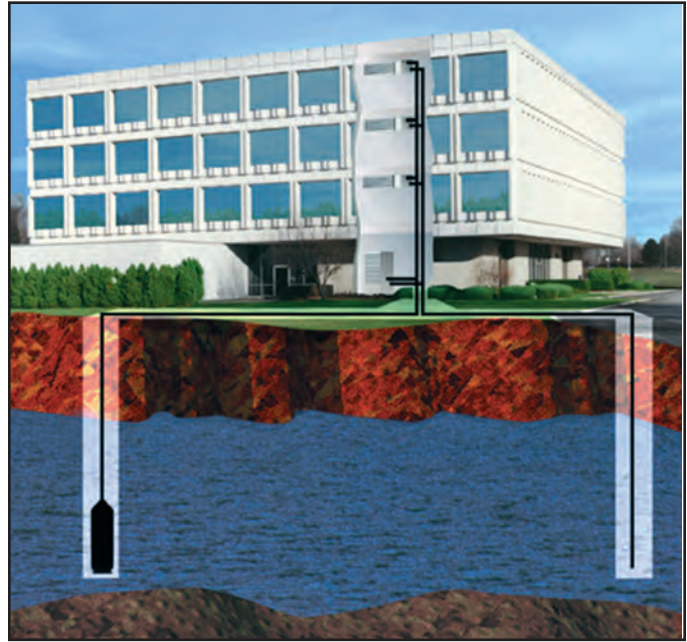

• **Closed Loop/Ground Water Plate Heat Exchanger Systems** utilize lake, ocean, well water or other water sources to maintain closed loop water temperatures in multi-unit LX Ultra Series systems. A plate frame heat exchanger isolates the units from any contaminating effects of the water source, and allows periodic cleaning of the heat exchanger during off peak hours.

Operation and benefits are similar to those for ground-source systems. Due to the extended loop temperatures, AHRI/ISO 13256-1 Ground Loop Heat Pumps are required for this application. Closed loop plate heat exchanger systems are applicable in commercial, marine, or industrial structures where the many benefits of a water source heat pump system are desired, regardless of whether the load is heating or cooling dominated.

Application Notes cont.

Cooler/Boiler - Closed Loop



• **Closed Loop /Cooler-Boiler Systems** utilize a closed heat recovering loop with multiple water source heat pumps in the more conventional manner. Typically a boiler is employed to maintain closed loop temperatures above 60°F and a cooling tower to maintain loop temperatures below 90°F. These systems are applicable in medium to large buildings regardless of whether the load is heating or cooling dominated. Due to the moderate loop temperatures, AHRI/ISO 13256-1 Water Loop Heat Pumps are required for this application.

Water Quality

In ground water situations where scaling could be heavy or where biological growth such as iron bacteria will be present, a closed loop system is recommended. The heat exchanger coils in ground water systems may, over a period of time, lose heat exchange capabilities due to a buildup of mineral deposits inside. These can be cleaned, but only by a qualified service mechanic, as special solutions and pumping equipment are required. Hot water generator coils can likewise become scaled and possibly plugged.

In areas with extremely hard water, the owner should be informed that the heat exchanger may require occasional flushing. Failure to adhere to the guidelines in the water quality table could result in loss of warranty.

Units with cupronickel heat exchangers are recommended for open loop applications due to the increased resistance to build-up and corrosion, along with reduced wear caused by acid cleaning.

Material		Copper	90/10 Cupronickel	316 Stainless Steel
pH	Acidity/Alkalinity	7 - 9	7 - 9	7 - 9
Scaling	Calcium and Magnesium Carbonate	(Total Hardness) less than 350 ppm	(Total Hardness) less than 350 ppm	(Total Hardness) less than 350 ppm
Corrosion	Hydrogen Sulfide	Less than 0.5 ppm (rotten egg smell appears at 0.5 ppm)	10 - 50 ppm	Less than 1 ppm
	Sulfates	Less than 125 ppm	Less than 125 ppm	Less than 200 ppm
	Chlorine	Less than 0.5 ppm	Less than 0.5 ppm	Less than 0.5 ppm
	Chlorides	Less than 20 ppm	Less than 125 ppm	Less than 300 ppm
	Carbon Dioxide	Less than 50 ppm	10 - 50 ppm	10 - 50 ppm
	Ammonia	Less than 2 ppm	Less than 2 ppm	Less than 20 ppm
	Ammonia Chloride	Less than 0.5 ppm	Less than 0.5 ppm	Less than 0.5 ppm
	Ammonia Nitrate	Less than 0.5 ppm	Less than 0.5 ppm	Less than 0.5 ppm
	Ammonia Hydroxide	Less than 0.5 ppm	Less than 0.5 ppm	Less than 0.5 ppm
	Ammonia Sulfate	Less than 0.5 ppm	Less than 0.5 ppm	Less than 0.5 ppm
	Total Dissolved Solids (TDS)	Less than 1000 ppm	1000 - 1500 ppm	1000 - 1500 ppm
	LSI Index	+0.5 to -0.5	+0.5 to -0.5	+0.5 to -0.5
Iron Fouling (Biological Growth)	Iron, FE ²⁺ (Ferrous) Bacterial Iron Potential	< 0.2 ppm	< 0.2 ppm	< 0.2 ppm
	Iron Oxide	Less than 1 ppm, above this level deposition will occur	Less than 1 ppm, above this level deposition will occur	Less than 1 ppm, above this level deposition will occur
Erosion	Suspended Solids	Less than 10 ppm and filtered for max. of 600 micron size	Less than 10 ppm and filtered for max. of 600 micron size	Less than 10 ppm and filtered for max. of 600 micron size
	Threshold Velocity (Fresh Water)	< 6 ft/sec	< 6 ft/sec	< 6 ft/sec

NOTES: Grains = ppm divided by 17
mg/L is equivalent to ppm

Installation Notes

Typical Unit Installation

Unit Location

Locate the unit in an indoor area that allows for easy removal of the filter and access panels. Location should have enough space for service personnel to perform maintenance or repair. Provide sufficient room to make water, electrical and duct connection(s). If the unit is located in a confined space, such as a closet, provisions must be made for return air to freely enter the space by means of a louvered door, etc. Any access panel screws that would be difficult to remove after the unit is installed should be removed prior to setting the unit. On horizontal units, allow adequate room below the unit for a condensate drain trap and do not locate the unit above supply piping. Care should be taken when units are located in unconditioned spaces to prevent damage from frozen water lines and excessive heat that could damage electrical components.

Water Piping

Piping is usually design as 'reverse return' to equalize flow paths through each unit. A short flexible pressure rated hose is used to make connection to the fixed building piping system. This hose

is typically stainless steel braid and includes a swivel fitting on one end for easy removal and is flexible to help isolate the unit for quieter operation. Isolation valves for servicing, y-strainers for filtering and memory-stop flow valve or a balancing valve can be provided for consistent water flow through the unit.

All unit source water connections are fittings that accept a male pipe thread (MPT). Insert the connectors by hand, then tighten the fitting with a wrench to provide a leakproof joint. The open and closed loop piping system should include pressure/temperature ports for serviceability. The proper water flow must be provided to each unit whenever the unit operates. To assure proper flow, use pressure/temperature ports to determine the flow rate. These ports should be located at the supply and return water connections on the unit. The proper flow rate cannot be accurately set without measuring the water pressure drop through the refrigerant-to-water heat exchanger. Never use flexible hoses smaller than the inside diameter of the water connection at the unit. Limit hose length to 10 feet per connection. Check carefully for water leaks.

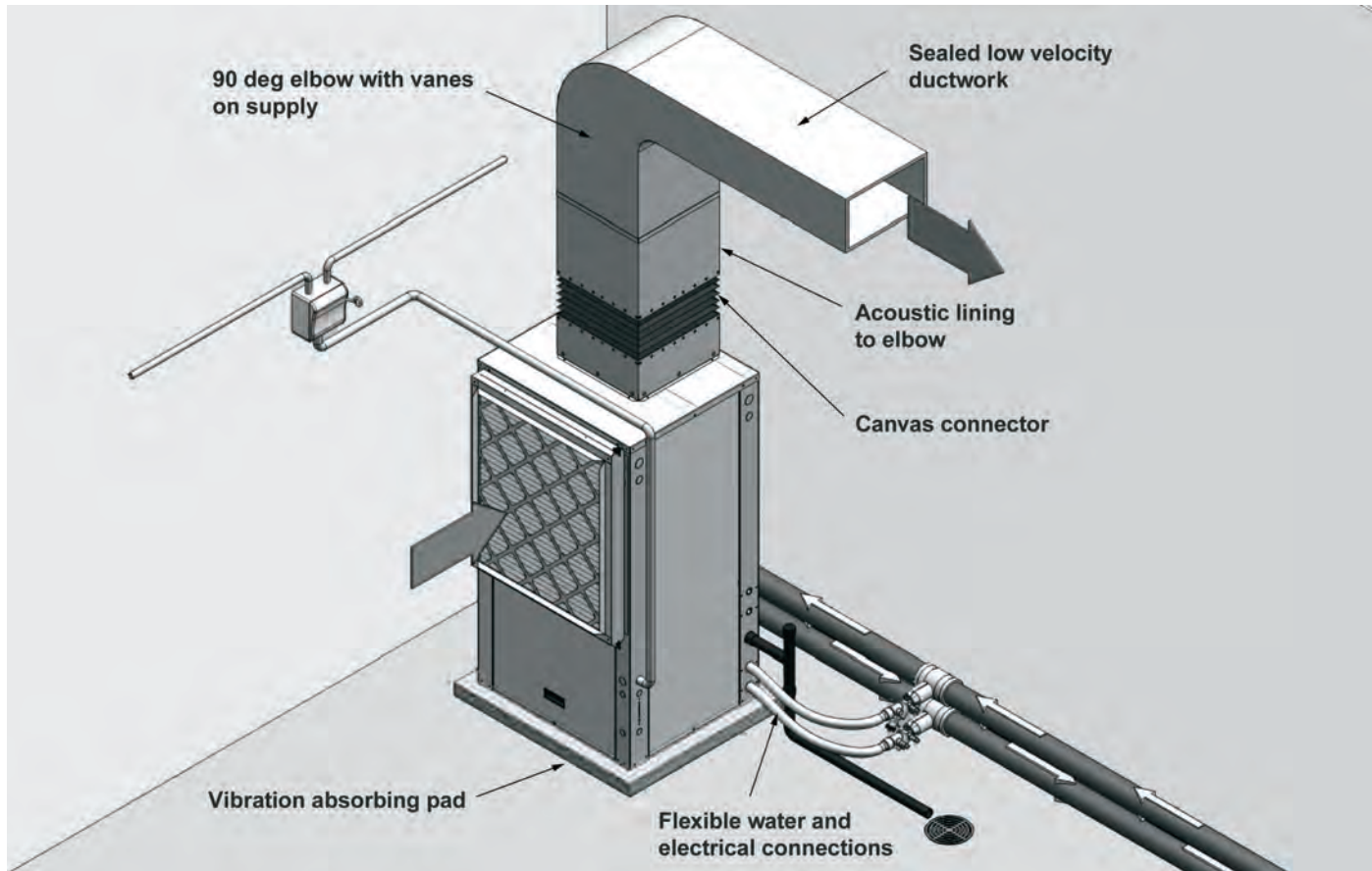

Installation Notes cont.

Installing Horizontal Units

Remove and discard the compressor hold down shipping bolt located at the front of the compressor mounting bracket prior to setting the unit in place. Horizontal units are available with side or end discharge.

NOTE: Left (Right) Return Side Discharge cannot be converted to Left (Right) Return End Discharge or vice versa, without additional custom sheet metal parts. Horizontal units are normally suspended from a ceiling by four (009-060 models) or five (070-072 models) 3/8 in. diameter threaded rods. The rods are usually attached to the unit by hanger bracket kits furnished with each unit.

Lay out the threaded rods per the Hanger Bracket Dimensions table. Assemble the hangers to the unit as shown. Securely tighten the brackets to the unit using the weld nuts located on the underside of the bottom panel. When attaching the hanger rods to the bracket, a double nut is required since vibration could loosen a single nut. To allow filter access, install hanger brackets as illustrated in the Hanger Bracket Locations section. The unit should be pitched approximately 1/4 in. towards the drain in both

directions to facilitate the removal of condensate. Use only the bolts provided in the kit to attach hanger brackets. The use of longer bolts could damage internal parts.

Some applications require the installation of horizontal units on an attic floor. In this case, the unit should be set in a full size secondary drain pan on top of a vibration absorbing pad. The secondary drain pan prevents possible condensate overflow or water leakage damage to the ceiling. The secondary drain pan is usually placed on a plywood base isolated from the ceiling joists by additional layers of vibration absorbing material.



CAUTION: Do not use rods smaller than 3/8 in. diameter since they may not be strong enough to support the unit. The rods must be securely anchored to the ceiling.

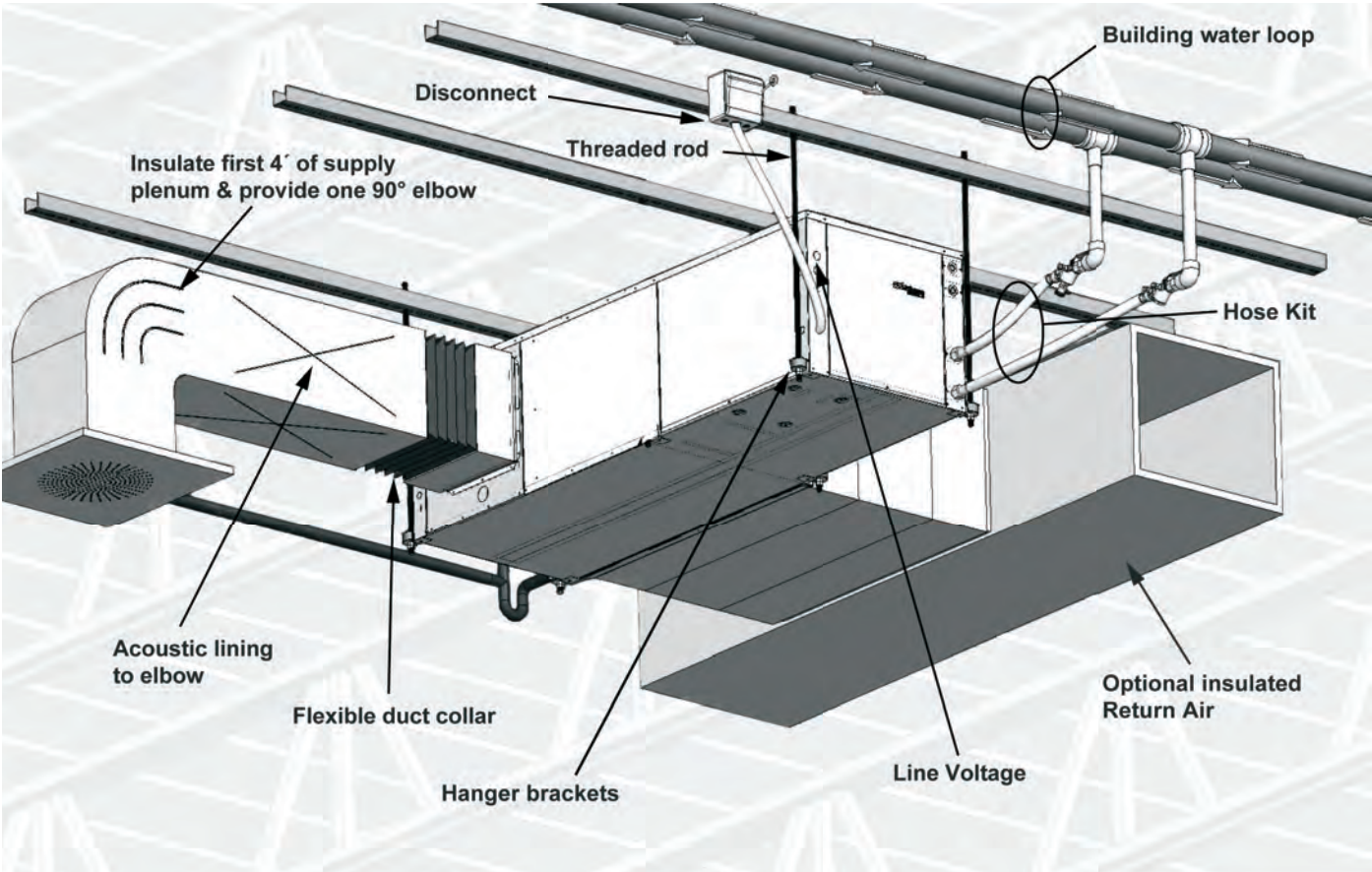

Installation Notes cont.

Acoustical Considerations and Equipment Sound Performance

Sound Performance

The LX Ultra Series is third party sound rated in accordance with ARI 260. Please consult the Sound Performance Data Catalog for details on the AHRI standard and sound performance data.

Recommendations for Noise Reduction

Horizontal Unit Location

- Specify equipment with quietest sound power ratings
- Do not locate units above areas with a required NC 40 or less
- Space WSHP at least 10 ft (3m) apart to avoid noise summing of multiple units in a space.
- Maximize the height of the unit above the ceiling (horizontal).
- Suspend unit with isolation grommets that are appropriately rated to reduce vibrations (horizontal).

Vertical Unit Location

- Specify equipment with quietest sound power ratings
- Space WSHP at least 10 ft (3m) apart to avoid noise summing of multiple units in a space.
- Acoustic ceiling coatings can greatly reduce noise levels in mechanical rooms.
- Mount unit on a sound absorbing pad, extruded polystyrene, rubber or cork pad.

Ductwork

- Ensure return air grilles will not allow line of sight noise to transfer to adjacent space. Use a sound barrier or some other material to isolate the grille from the unit. A supply grille, boot and short piece of flex duct pointed away from the unit can greatly attenuate equipment noise.
- Use a canvas isolation duct connector at the supply and return duct connection of the unit.
- Internally line the discharge and return duct within the first 4-8 feet of unit with acoustic insulation. Install an internally lined 'L' shaped return duct elbow at return grille. Face the elbow away from adjacent units.
- Always install at least one 90° elbow in the discharge duct to eliminate line of sight noise transmission of the blower.
- Use turning vanes at all elbows and tees to reduce turbulence.
- Limit supply duct velocities to less than 1,000 fpm
- Design and install ductwork as stiff as possible
- Allow 3 duct diameters both up and down stream of the unit before any fittings or transitions are installed.
- Use duct sealant on all duct joints.
- Install a short (2-4') of flex duct on all branch ducts just prior to discharge boot or diffuser to reduce vibration and duct sound prior to delivery in the room.
- Locate the branch duct balancing damper as far away from the diffuser as possible.
- In ceiling plenum systems, install an internally lined 'L' shaped return duct elbow at unit. Face the elbow away from adjacent units (horizontal).

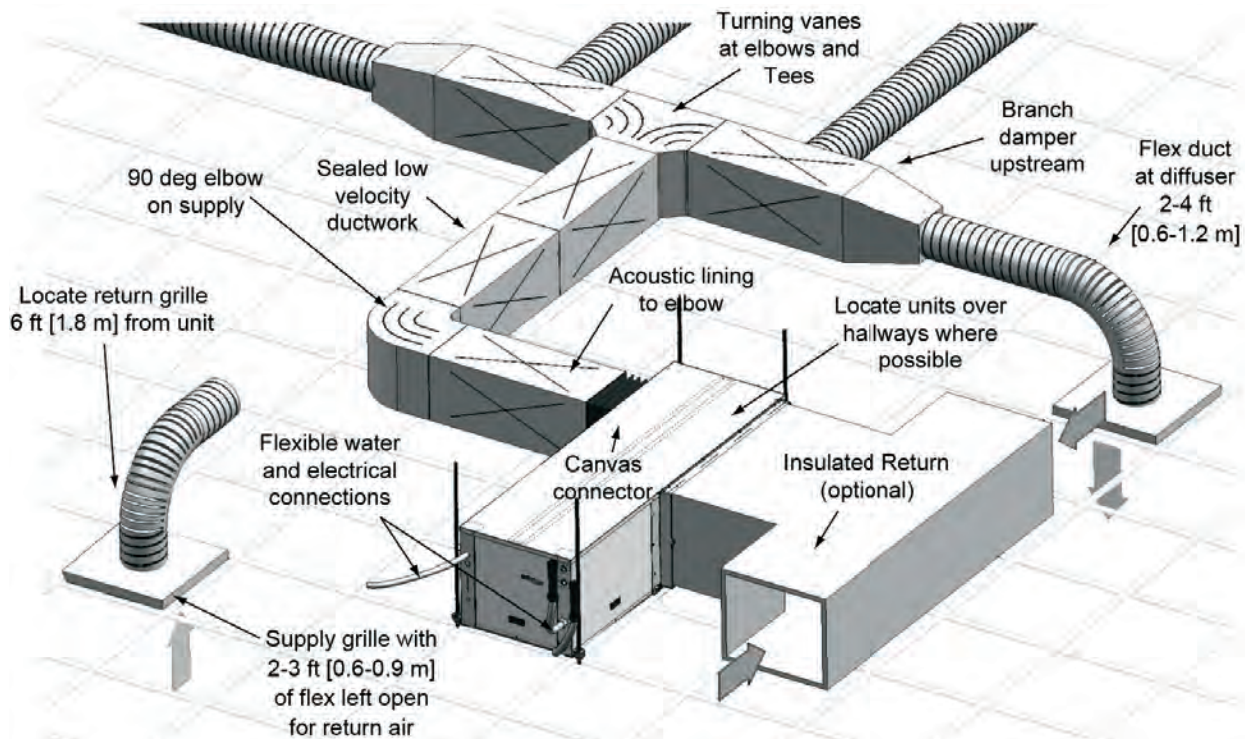

Vertical Dimensional Data

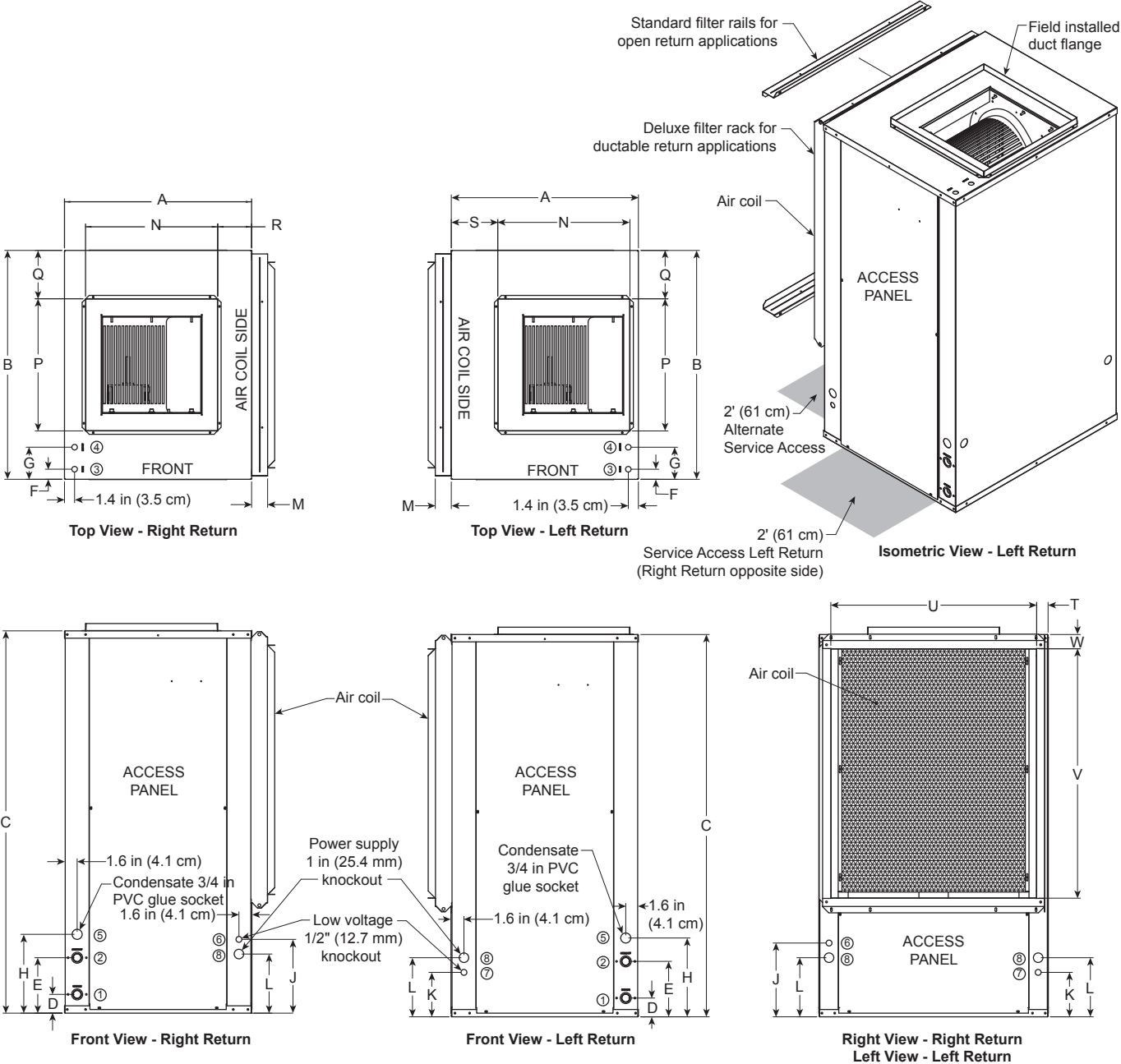

Vertical Dimensional Data cont.

Vertical Models	Overall Cabinet			Water Connections							Electrical Knockouts			
	A	B	C	1	2	3	4	5	Loop	Knock-out	6	7	8	
	Width	Depth	Height**	D	E	F	G	H			J	K	L	
				In	Out	HWG In	HWG Out	Condensate	Water FPT	HWG Provisions	1/2 in. cond	1/2 in. cond	1 in. cond	
009-012	in.	22.5	22.2	23.7	2.6	5.6	N/A	N/A	8.8	1/2	N/A	7.4	3.4	5.4
	cm.	57.2	56.4	60.2	6.6	14.2	N/A	N/A	22.4	12.7 mm	N/A	18.8	8.6	13.7
015-018	in.	22.5	22.2	36.2	2.6	7.6	1.4	2.9	10.8	3/4	0.875	9.4	5.4	7.4
	cm.	57.2	56.4	91.9	6.6	19.3	3.6	7.4	27.4	19.1 mm	22.2 mm	23.9	13.7	18.8
024-030	in.	22.5	26.2	40.2	2.6	7.6	1.4	4.4	10.8	3/4	0.875	10.1	6.1	8.1
	cm.	57.2	66.5	102.1	6.6	19.3	3.6	11.2	27.4	19.1 mm	22.2 mm	25.7	15.5	20.6
036	in.	22.5	26.2	44.2	2.6	7.6	1.4	4.4	10.8	3/4	0.875	10.1	6.1	8.1
	cm.	57.2	66.5	112.3	6.6	19.3	3.6	11.2	27.4	19.1 mm	22.2 mm	25.7	15.5	20.6
041	in.	22.5	26.2	44.2	2.6	7.6	1.4	2.9	10.8	3/4	0.875	10.1	6.1	8.1
	cm.	57.2	66.5	112.3	6.6	19.3	3.6	7.4	27.4	19.1 mm	22.2 mm	25.7	15.5	20.6
042-048	in.	25.5	31.2	44.2	2.6	7.6	1.4	4.4	10.8	1	0.875	10.1	6.1	8.1
	cm.	64.8	79.2	112.3	6.6	19.3	3.6	11.2	27.4	25.4 mm	22.2 mm	25.7	15.5	20.6
060	in.	25.5	31.2	48.2	2.6	7.6	1.4	4.4	10.8	1	0.875	10.1	6.1	8.1
	cm.	64.8	79.2	122.4	6.6	19.3	3.6	11.2	27.4	25.4 mm	22.2 mm	25.7	15.5	20.6
070	in.	25.5	31.2	52.2	2.6	7.6	1.4	4.4	10.8	1	0.875	10.1	6.1	8.1
	cm.	64.8	79.2	132.6	6.6	19.3	3.6	11.2	27.4	25.4 mm	22.2 mm	25.7	15.5	20.6

Vertical Models	Discharge Connection duct flange installed (±0.10 in)						Return Connection* using deluxe filter rack (±0.10 in)				
	M	N	P	Q	R	S	T	U	V	W	
	Filter Rack Width	Supply Width	Supply Depth					Return Depth	Return Height		
009-012	in.	2.2	10.0	10.0	6.1	9.4	9.4	2.1	18.1	10.0	1.9
	cm.	5.6	25.4	25.4	15.5	23.9	23.9	5.3	46.0	25.4	4.8
015-018	in.	2.2	14.0	14.0	4.1	4.3	7.7	2.1	18.1	20.0	1.9
	cm.	5.6	35.6	35.6	10.4	10.9	19.6	5.3	46.0	50.8	4.8
024-030	in.	2.2	14.0	14.0	6.1	4.5	7.7	2.1	22.1	22.1	1.9
	cm.	5.6	35.6	35.6	15.5	11.4	19.6	5.3	56.1	56.1	4.8
036	in.	2.2	14.0	14.0	6.1	4.5	7.7	2.1	22.1	26.1	1.9
	cm.	5.6	35.6	35.6	15.5	11.4	19.6	5.3	56.1	66.3	4.8
041	in.	2.2	18.0	18.0	4.1	3.9	3.9	2.1	22.1	26.1	1.9
	cm.	5.6	45.7	45.7	10.4	9.9	9.9	5.3	56.1	66.3	4.8
042-048	in.	2.2	18.0	18.0	6.6	4.6	6.3	1.6	28.1	26.0	2.0
	cm.	5.6	45.7	45.7	16.8	11.7	16.0	4.1	71.4	66.0	5.1
060	in.	2.2	18.0	18.0	6.6	4.6	6.3	1.6	28.1	30.0	2.0
	cm.	5.6	45.7	45.7	16.8	11.7	16.0	4.1	71.4	76.2	5.1
070	in.	2.2	18.0	18.0	6.6	4.6	6.3	1.6	28.1	34.0	2.0
	cm.	5.6	45.7	45.7	16.8	11.7	16.0	4.1	71.4	86.4	5.1

Condensate is 3/4 in. PVC female glue socket and is switchable from side to front.

*Dimensions for return connections are for the deluxe filter rack that is suitable for ducted return applications and extends 3.25 in. [8.26 cm] from the unit. The open filter rack, used in non-ducted returns, extends 2.2 in. [5.59 cm] from the unit.

**Discharge flange is field installed and extends 1 in. (25.4 mm) from top of cabinet.

11/10/09

Vertical Disconnect

When using disconnect, do not use dimension L from the standard vertical dimensional data. Use dimension LL from the vertical disconnect dimensional data.

Vertical Models	LL
009-012	Externally Mounted
015-018	18.8 [47.8]
024-030	14.3 [36.3]
036	15.3 [38.9]
042-048	14.3 [36.3]
060	14.3 [36.3]
070	14.3 [36.3]

Dimensions in inches [cm]

02/06/13

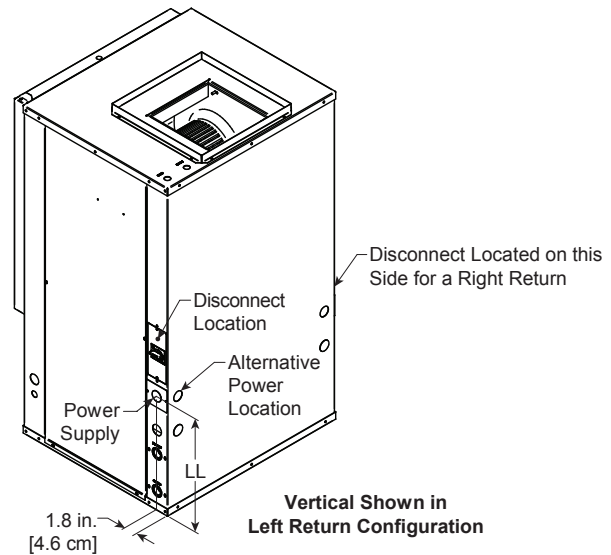

Horizontal Dimensional Data

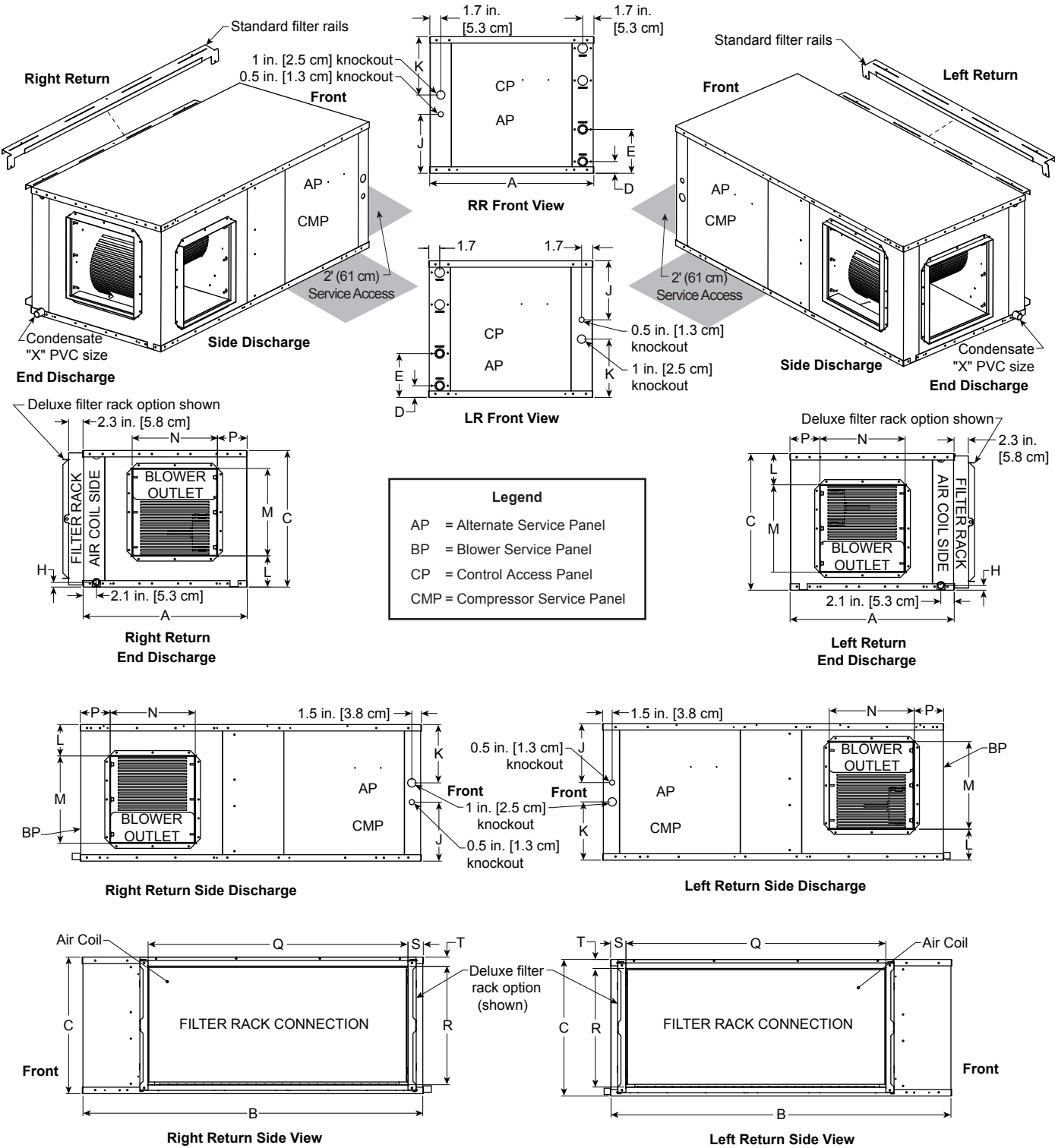

Horizontal Dimensional Data cont.

Horizontal Models		Overall Cabinet			Water Connections				Electrical Knockouts	
		A	B	C	1	2	3		J	K
		Width	Depth	Height*	D	E	H	Loop	1/2 in. cond	1 in. cond
009-012	in.	19.2	30.9	11.9	1.8	4.8	0.8	1/2	4.5	4.5
	cm.	48.8	78.5	30.2	4.6	12.2	2.0	12.7 mm	11.4	11.4
015-023	in.	22.5	42.0	17.2	1.8	6.8	0.8	3/4	7.1	7.1
	cm.	57.2	106.7	43.7	4.6	17.3	2.0	19.05 mm	18.0	18.0
024-030	in.	22.5	42.0	19.2	1.8	6.8	0.8	3/4	9.2	7.1
	cm.	57.2	106.7	48.8	4.6	17.3	2.0	19.05 mm	23.4	18.0
036	in.	22.5	45.0	19.2	1.8	6.8	0.8	3/4	9.2	7.1
	cm.	57.2	114.3	48.8	4.6	17.3	2.0	19.05 mm	23.4	18.0
042-048	in.	25.5	48.0	21.2	1.8	6.8	0.8	1	9.2	9.1
	cm.	64.8	121.9	53.8	4.6	17.3	2.0	25.4 mm	23.4	23.1
060	in.	25.5	53.0	21.2	1.8	6.8	0.8	1	9.2	9.1
	cm.	64.8	134.6	53.8	4.6	17.3	2.0	25.4 mm	23.4	23.1
070	in.	25.5	61.0	21.2	1.8	6.8	0.8	1	9.2	9.1
	cm.	64.8	154.9	53.8	4.6	17.3	2.0	25.4 mm	23.4	23.1

Horizontal Models		Discharge Connection duct flange installed (±0.10 in)				Return Connection* using deluxe filter rack option (±0.10 in)				PVC Size
		L	M	N	P	Q	R	S	T	X
			Supply Width	Supply Depth		Return Depth	Return Height			
009-012	in.	2.3	8.0	10.0	2.3	15.4	9.4	3.0	1.4	1/2
	cm.	5.8	20.3	25.4	5.8	39.1	23.9	7.6	3.6	1.3
015-023	in.	5.7	10.5	9.4	4.9	23.4	14.5	2.0	1.4	3/4
	cm.	14.5	26.7	23.9	12.4	59.4	36.8	5.1	3.6	1.9
024-030	in.	6.7	10.5	9.4	4.9	27.4	16.4	2.0	1.5	3/4
	cm.	17.0	26.7	23.9	12.4	69.6	41.7	5.1	3.8	1.9
036	in.	6.7	10.5	9.4	4.9	30.4	16.4	2.1	1.5	3/4
	cm.	17.0	26.7	23.9	12.4	77.2	41.7	5.3	3.8	1.9
042-048	in.	4.9	13.6	13.2	4.6	35.4	18.6	2.4	1.5	3/4
	cm.	12.4	34.5	33.5	11.7	89.9	47.2	6.1	3.8	1.9
060	in.	4.9	13.6	13.2	4.6	40.4	18.4	2.4	1.5	3/4
	cm.	12.4	34.5	33.5	11.7	102.6	46.7	6.1	3.8	1.9
070	in.	4.9	13.6	13.2	4.6	45.6	18.6	2.3	1.5	3/4
	cm.	12.4	34.5	33.5	11.7	115.8	47.2	5.8	3.8	1.9

*Dimensions for return connections are for the deluxe filter rack that is suitable for ducted return applications and extends 3.25 in. [8.26 cm] from the unit. The open filter rack, used in non-ducted returns, extends 2.2 in. [5.59 cm] from the unit. Condensate 3/4 in. PVC stub extends from cabinet approximately 1-1/2 in. [38.1 mm]

10/29/13

Horizontal Disconnect

When using disconnect, do not use dimension K from the standard horizontal dimensional data. Use dimension KK from the horizontal disconnect dimensional data.

Horizontal Models	KK
009-012	Externally Mounted
015-018	8.2 [20.8]
024-030	9.2 [23.4]
036	9.2 [23.4]
042-048	11.2 [28.4]
060	10.2 [25.9]
070	11.2 [28.4]

Dimensions in inches [cm]

02/06/13

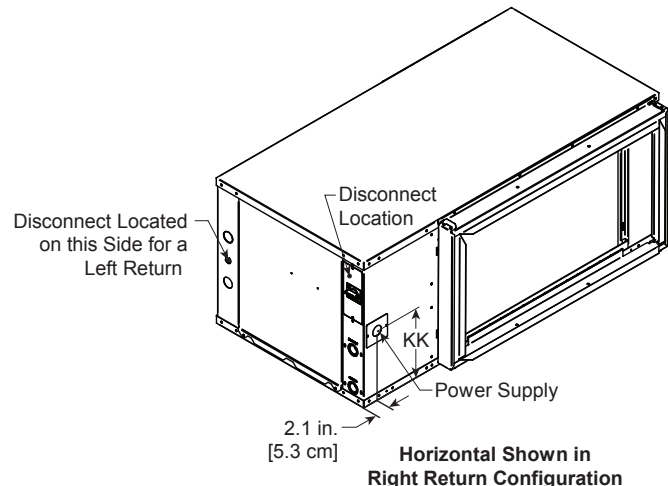

Hanger Bracket Locations

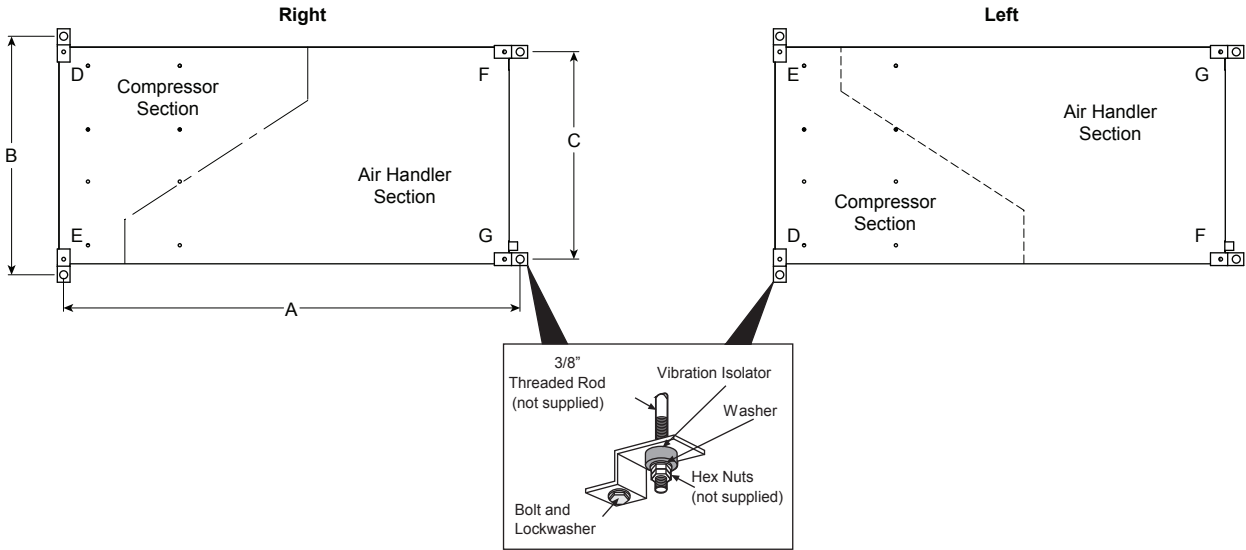

Hanger Dimensions

Model	Hanger Kit Part Number	Unit Hanger Dimensions		
		A	B	C
009-012	in.	31.7	21.8	18.1
	cm	[80.5]	[55.4]	[46.0]
015-023	in.	42.8	25.1	21.4
	cm	[108.6]	[63.8]	[54.4]
024-030	in.	42.8	25.1	21.4
	cm	[108.7]	[63.8]	[54.4]
036	in.	45.8	25.1	21.4
	cm	[116.3]	[63.8]	[54.4]
042-048	in.	48.8	28.1	24.4
	cm	[124.0]	[71.4]	[62.0]
060	in.	53.8	28.1	24.4
	cm	[136.7]	[71.4]	[62.0]
070	in.	61.8	28.1	24.4
	cm	[157.0]	[71.4]	[62.0]

10/29/13

Weight Distribution

Model	Vertical Shipping Weight	Horizontal Shipping Weight	Horizontal Weight Distribution				
			Front		Back		
			D	E	F	G	
009	lb.	110	120	46	23	26	25
	kg	[50]	[54]	[21]	[11]	[12]	[11]
012	lb.	115	125	48	24	27	26
	kg	[52]	[57]	[22]	[11]	[12]	[12]
015	lb.	165	175	67	34	37	36
	kg	[75]	[79]	[31]	[15]	[17]	[17]
018	lb.	170	180	69	35	38	38
	kg	[77]	[82]	[31]	[16]	[17]	[17]
023	lb.	na	185	71	36	39	39
	kg	na	[84]	[32]	[16]	[18]	[17]
024	lb.	230	245	94	47	52	51
	kg	[104]	[111]	[43]	[22]	[24]	[23]
030	lb.	240	255	98	49	54	53
	kg	[109]	[116]	[44]	[22]	[25]	[24]
036	lb.	265	285	110	55	61	59
	kg	[120]	[129]	[50]	[25]	[28]	[27]
041	lb.	275	na	na	na	na	na
	kg	[125]	na	na	na	na	na
042	lb.	285	300	115	58	64	63
	kg	[129]	[136]	[52]	[26]	[29]	[28]
048	lb.	290	310	119	60	66	65
	kg	[132]	[141]	[54]	[27]	[30]	[29]
060	lb.	335	360	138	70	77	75
	kg	[152]	[163]	[63]	[32]	[35]	[34]
070	lb.	380	405	156	78	86	84
	kg	[172]	[184]	[71]	[36]	[39]	[38]

11/10/09

Physical Data

Model		Single Speed												
		009	012	015	018	023	024	030	036	041	042	048	060	070
Compressor (1 each)		Rotary						Scroll						
Factory Charge R-410A, oz [kg] Vertical		26 [0.74]	32 [0.91]	38 [1.08]	40 [1.13]	n/a	46 [1.30]	54 [1.53]	56 [1.59]	54 [1.53]	68 [1.93]	76 [2.15]	88 [2.49]	92 [2.61]
Factory Charge R-410A, oz [kg] Horizontal		24 [0.68]	26 [0.74]	30 [0.85]	32 [0.91]	46 [1.30]	46 [1.30]	56 [1.59]	60 [1.70]	n/a	68 [1.93]	76 [2.15]	88 [2.49]	88 [2.49]
Blower Motor & Blower														
Blower Motor Type/Speeds	VS ECM	Not Available			Variable Speed									
	PSC	4 Speeds			3 Speeds									
	5-Spd ECM	Not Available			5 Speeds									
Blower Motor- hp [W]	VS ECM	Not Available		1/2 [373]	1/2 [373]	1/2 [373]	1/2 [373]	1/2 [373]	1/2 [373]	1/2 [373]	1/2 [373]	1/2 [373]	1 [746]	1 [746]
	PSC	1/10 [75]	1/10 [75]	1/6 [134]	1/6 [134]	1/5 [149]	1/5 [149]	1/3 [249]	1/2 [373]	1/2 [373]	1/2 [373]	1/2 [373]	1 [746]	1 [746]
	5-Spd ECM	Not Available		1/2 [373]	1/2 [373]	1/2 [373]	1/2 [373]	1/2 [373]	1/2 [373]	1 [746]	1 [746]	1 [746]	1 [746]	1 [746]
Optional - Oversized Blower Motor - hp [W]	VS ECM	Not Available									1 [746]	1 [746]	Not Available	
	PSC	Not Available					1/3 [249]	1/2 [373]	Not Available		3/4 [560]	3/4 [560]	Not Available	
Blower Wheel Size (Dia x W), in. [mm]	VS ECM	Not Available		9x7 [229 x 178]	9x7 [229 x 178]	9x7 [229 x 178]	9x7 [229 x 178]	9x7 [229 x 178]	9x7 [229 x 178]	10x10 [254 x 254]	11x10 [279 x 254]	11x10 [279 x 254]	11x10 [279 x 254]	11x10 [279 x 254]
	PSC	6x8 [152 x 203]	6x8 [152 x 203]	9x7 [229 x 178]	9x7 [229 x 178]	9x7 [229 x 178]	9x7 [229 x 178]	9x7 [229 x 178]	9x7 [229 x 178]	10x10 [254 x 254]	10x10 [254 x 254]	10x10 [254 x 254]	11x10 [279 x 254]	11x10 [279 x 254]
	5-Spd ECM	Not Available		9x7 [229 x 178]	9x7 [229 x 178]	9x7 [229 x 178]	9x7 [229 x 178]	9x7 [229 x 178]	9x7 [229 x 178]	11x10 [279 x 254]	11x10 [279 x 254]	11x10 [279 x 254]	11x10 [279 x 254]	11x10 [279 x 254]
Coax and Water Piping														
Water Connection Size - FPT - in. [mm]		1/2 [12.7]	1/2 [12.7]	3/4 [19.1]	3/4 [19.1]	3/4 [19.1]	3/4 [19.1]	3/4 [19.1]	3/4 [19.1]	3/4 [19.1]	1 [25.4]	1 [25.4]	1 [25.4]	1 [25.4]
HWG Connection Size - FPT - in. [mm] (Vertical Only)		Not Available			1/2 [12.7]	1/2 [12.7]	1/2 [12.7]	1/2 [12.7]	1/2 [12.7]	1/2 [12.7]	1/2 [12.7]	1/2 [12.7]	1/2 [12.7]	1/2 [12.7]
Coax & Piping Water Volume - gal [l]		0.26 [0.98]	0.3 [1.12]	0.4 [1.49]	0.4 [1.49]	0.4 [1.49]	0.4 [1.49]	0.75 [2.83]	0.9 [3.41]	0.9 [3.41]	0.9 [3.41]	1.25 [4.72]	1.5 [5.68]	1.5 [5.68]
Vertical														
Air Coil Dimensions (H x W), in. [mm]		12 x 16 [305 x 406]	12 x 16 [305 x 406]	22 x 16 [559 x 406]	22 x 16 [559 x 406]	n/a	24 x 20 [610 x 508]	24 x 20 [610 x 508]	28 x 20 [711 x 508]	28 x 20 [711 x 508]	28 x 25 [711 x 635]	28 x 25 [711 x 635]	32 x 25 [813 x 635]	36 x 25 [914 x 635]
Air Coil Total Face Area, ft² [m²]		1.3 [0.121]	1.3 [0.121]	2.4 [0.220]	2.4 [0.220]	n/a	3.3 [0.310]	3.3 [0.310]	3.9 [0.362]	3.9 [0.362]	4.9 [0.452]	4.9 [0.452]	5.6 [0.516]	6.3 [0.581]
Air Coil Tube Size, in. [mm]		3/8 [9.5]	3/8 [9.5]	3/8 [9.5]	3/8 [9.5]	n/a	3/8 [9.5]	3/8 [9.5]	3/8 [9.5]	3/8 [9.5]	3/8 [9.5]	3/8 [9.5]	3/8 [9.5]	3/8 [9.5]
Air Coil Number of rows		3	3	3	3	n/a	3	3	3	3	3	3	3	3
Filter Standard - 1 in. [25mm] MERV4 Throwaway, in. [mm]		12 x 20 [305 x 508]	12 x 20 [305 x 508]	22 x 20 [559 x 508]	22 x 20 [559 x 508]	n/a	24 x 24 [610 x 610]	24 x 24 [610 x 610]	28 x 24 [711 x 610]	28 x 24 [711 x 610]	28 x 30 [711 x 762]	28 x 30 [711 x 762]	32 x 30 [813 x 762]	36 x 30 [914 x 762]
Filter Standard - 2 in. [51mm] Pleated MERV13 Throwaway, in. [mm]		12 x 20 [305 x 508]	12 x 20 [305 x 508]	22 x 20 [559 x 508]	22 x 20 [559 x 508]	n/a	24 x 24 [610 x 610]	24 x 24 [610 x 610]	28 x 24 [711 x 610]	28 x 24 [711 x 610]	28 x 30 [711 x 762]	28 x 30 [711 x 762]	32 x 30 [813 x 762]	36 x 30 [914 x 762]
Horizontal														
Air Coil Dimensions (H x W), in. [mm]		10 x 16 [254 x 406]	10 x 16 [254 x 406]	16 x 23 [406 x 584]	16 x 23 [406 x 584]	16 x 23 [406 x 584]	18 x 27 [457 x 686]	18 x 27 [457 x 686]	18 x 30 [457 x 762]	n/a	20 x 35 [508 x 889]	20 x 35 [508 x 889]	20 x 40 [508 x 1016]	20 x 45 [508 x 1143]
Air Coil Total Face Area, ft² [m²]		1.1 [0.103]	1.1 [0.103]	2.6 [0.238]	2.6 [0.238]	2.6 [0.238]	3.4 [0.316]	3.4 [0.316]	3.9 [0.362]	n/a	4.9 [0.452]	4.9 [0.452]	5.6 [0.516]	6.3 [0.581]
Air Coil Tube Size, in. [mm]		3/8 [9.5]	3/8 [9.5]	3/8 [9.5]	3/8 [9.5]	3/8 [9.5]	3/8 [9.5]	3/8 [9.5]	3/8 [9.5]	n/a	3/8 [9.5]	3/8 [9.5]	3/8 [9.5]	3/8 [9.5]
Air Coil Number of rows		3	3	3	3	3	3	3	3	n/a	3	3	3	3
Filter Standard - 1 in. [25mm] MERV 4 Throwaway, in. [mm]		11 x 17 [279 x 432]	11 x 17 [279 x 432]	16 x 25 [406 x 635]	16 x 25 [406 x 635]	16 x 25 [406 x 635]	2 - 18 x 14 [457 x 356]	2 - 18 x 14 [457 x 356]	1 - 18 x 14 [457 x 356] 1 - 18 x 18 [457 x 457]	n/a	2 - 18 x 20 [457 x 508]	2 - 18 x 20 [457 x 508]	1 - 20 x 20 [508 x 508] 1 - 20 x 22 [508 x 559]	1 - 20 x 25 [508 x 635] 1 - 20 x 22 [508 x 559]
Filter Standard - 2 in. [51mm] Pleated MERV 13 Throwaway, in. [mm]		11 x 17 [279 x 432]	11 x 17 [279 x 432]	16 x 25 [406 x 635]	16 x 25 [406 x 635]	16 x 25 [406 x 635]	18 x 29 [457 x 737]	18 x 29 [457 x 737]	18 x 32 [457 x 813]	n/a	20 x 37 [686 x 940]	20 x 37 [686 x 940]	1 - 20 x 20 [508 x 508] 1 - 20 x 22 [508 x 559]	1 - 20 x 25 [508 x 635] 1 - 20 x 22 [508 x 559]

Electrical Availability

PSC

Voltage	Static Option	Single Speed Models												
		009	012	015	018	023	024	030	036	041	042	048	060	070
208-230/60/1	Standard	*	*	*	*	*	*	*	*	*	*	*	*	*
208-230/60/1 w/IntelliStart					*	*	*	*	*	*	*	*	*	*
265-277/60/1		*	*	*	*	*	*	*	*					
208-230/60/3 (also w/IntelliStart)						*	*	*	*	*	*	*	*	*
460/60/3 (also w/IntelliStart)						*	*	*	*	*	*	*	*	*
575/60/3										*	*		*	*
208-230/60/1	High						*	*			*	*		
208-230/60/1 w/IntelliStart							*	*			*	*		
265-277/60/1							*	*						
208-230/60/3 (also w/IntelliStart)							*	*			*	*		
460/60/3 (also w/IntelliStart)							*	*			*	*		
575/60/3											*	*		

01/22/13

Variable Speed ECM

Voltage	Static Option	Single Speed Models												
		009	012	015	018	023	024	030	036	041	042	048	060	070
208-230/60/1	Standard			*	*	*	*	*	*	*	*	*	*	*
208-230/60/1 w/IntelliStart					*	*	*	*	*	*	*	*	*	*
265-277/60/1		*	*	*	*	*	*	*	*					
208-230/60/3 (also w/IntelliStart)						*	*	*	*	*	*	*	*	*
460/60/3 (also w/IntelliStart)						*	*	*	*	*	*	*	*	*
575/60/3														
208-230/60/1	High										*	*		
208-230/60/1 w/IntelliStart											*	*		
265-277/60/1														
208-230/60/3 (also w/IntelliStart)											*	*		
460/60/3 (also w/IntelliStart)											*	*		
575/60/3														

01/22/13

5-Speed ECM

Voltage	Static Option	Single Speed Models												
		009	012	015	018	023	024	030	036	041	042	048	060	070
208-230/60/1	Standard			*	*	*	*	*	*	*	*	*	*	*
208-230/60/1 w/IntelliStart					*	*	*	*	*	*	*	*	*	*
265-277/60/1						*	*	*	*					
208-230/60/3 (also w/IntelliStart)						*	*	*	*	*	*	*	*	*
460/60/3 (also w/IntelliStart)						*	*	*	*	*	*	*	*	*
575/60/3														

01/22/13

Electrical Data

PSC Motor

Model	Rated Voltage	Voltage Min/Max	Compressor				Blower Motor FLA	Total Unit FLA	Min Circ Amp	Max Fuse/HACR
			MCC	RLA	LRA	LRA**				
009	208-230/60/1	187/253	6.4	4.1	21.0	n/a	0.6	4.7	5.7	10/15
	265/60/1	238/292	6.7	4.3	22.0	n/a	0.6	4.9	6.0	10/15
012	208-230/60/1	187/253	7.7	4.9	25.0	n/a	0.6	5.5	6.7	10/15
	265/60/1	238/292	7.0	4.5	22.0	n/a	0.6	5.1	6.2	10/15
015	208-230/60/1	187/253	9.2	5.9	29.0	n/a	1.1	7.0	8.5	10/15
	265/60/1	238/292	7.8	5.0	28.0	n/a	1.0	6.0	7.2	10/15
018	208-230/60/1	187/253	10.4	6.7	33.5	13.4	1.1	7.8	9.5	15
	265/60/1	238/292	8.7	5.6	28.0	n/a	1.0	6.6	8.0	10/15
023	208-230/60/1	187/253	21.0	13.5	58.3	23.3	1.2	14.7	18.1	30
	265/60/1	238/292	14.0	9.0	54.0	n/a	1.1	10.1	12.4	20
	208-230/60/3	187/253	11.0	7.1	55.0	33.0	1.2	8.3	10.1	15
	460/60/3	414/506	5.5	3.5	28.0	16.8	0.6	4.1	5.0	10/15
024	208-230/60/1	187/253	21.0	13.5	58.3	23.3	1.2	14.7	18.1	30
	265/60/1	238/292	14.0	9.0	54.0	n/a	1.1	10.1	12.4	20
	208-230/60/3	187/253	11.0	7.1	55.0	33.0	1.2	8.3	10.1	15
	460/60/3	414/506	5.5	3.5	28.0	16.8	0.6	4.1	5.0	10/15
024*	208-230/60/1	187/253	21.0	13.5	58.3	23.3	1.5	15.0	18.4	30
	265/60/1	238/292	14.0	9.0	54.0	n/a	1.5	10.5	12.8	20
	208-230/60/3	187/253	11.0	7.1	55.0	33.0	1.5	8.6	10.4	15
	460/60/3	414/506	5.5	3.5	28.0	16.8	1.0	4.5	5.4	10/15
030	208-230/60/1	187/253	22.0	14.1	73.0	29.2	1.5	15.6	19.1	30
	265/60/1	238/292	17.5	11.2	60.0	n/a	1.5	12.7	15.5	25
	208-230/60/3	187/253	13.9	8.9	58.0	34.8	1.5	10.4	12.6	20
	460/60/3	414/506	6.5	4.2	28.0	16.8	1.0	5.2	6.3	10/15
030*	208-230/60/1	187/253	22.0	14.1	73.0	29.2	2.2	16.3	19.8	30
	265/60/1	238/292	17.5	11.2	60.0	n/a	2.0	13.2	16.0	25
	208-230/60/3	187/253	13.9	8.9	58.0	34.8	2.2	11.1	13.3	20
	460/60/3	414/506	6.5	4.2	28.0	16.8	1.1	5.3	6.4	10/15
036	208-230/60/1	187/253	27.0	17.3	96.7	38.7	2.2	19.5	23.8	40
	265/60/1	238/292	19.0	12.2	72.0	n/a	1.1	13.3	16.3	20
	208-230/60/3	187/253	20.0	12.8	95.0	57.0	2.2	15.0	18.2	30
	460/60/3	414/506	10.0	6.4	45.0	27.0	1.1	7.5	9.1	15
041	208-230/60/1	187/253	31.0	20.0	115.0	46.0	3.5	23.5	28.5	45
	208-230/60/3	187/253	20.0	12.8	95.0	57.0	3.5	16.3	19.5	30
	460/60/3	414/506	10.0	6.4	45.0	27.0	1.8	8.2	9.8	15
	575/60/3	517/633	8.5	5.4	38.0	n/a	1.4	6.8	8.2	10/15
042	208-230/60/1	187/253	31.0	20.0	115.0	46.0	3.5	23.5	28.5	45
	208-230/60/3	187/253	20.0	12.8	95.0	57.0	3.5	16.3	19.5	30
	460/60/3	414/506	10.0	6.4	45.0	27.0	1.8	8.2	9.8	15
	575/60/3	517/633	8.5	5.4	38.0	n/a	1.4	6.8	8.2	10/15
042*	208-230/60/1	187/253	31.0	20.0	115.0	46.0	4.6	24.6	29.6	45
	208-230/60/3	187/253	20.0	12.8	95.0	57.0	4.6	17.4	20.6	30
	460/60/3	414/506	10.0	6.4	45.0	27.0	2.3	8.7	10.3	15
	575/60/3	517/633	8.5	5.4	38.0	n/a	1.9	7.3	8.7	10/15
048	208-230/60/1	187/253	32.0	21.0	115.0	46.0	3.5	24.5	29.8	50
	208-230/60/3	187/253	25.0	16.0	115.0	69.0	3.5	19.5	23.5	35
	460/60/3	414/506	12.0	7.7	50.0	30.0	1.8	9.5	11.4	15
048*	208-230/60/1	187/253	32.0	21.0	115.0	46.0	4.6	25.6	30.9	50
	208-230/60/3	187/253	25.0	16.0	115.0	69.0	4.6	20.6	24.6	40
	460/60/3	414/506	12.0	7.7	50.0	30.0	2.3	10.0	11.9	15
	575/60/3	517/633	10.0	6.4	40.0	n/a	1.9	8.3	9.9	15
060	208-230/60/1	187/253	41.0	26.3	150.0	60.0	5.9	32.3	38.8	60
	208-230/60/3	187/253	27.5	17.6	120.0	72.0	5.9	23.5	27.9	45
	460/60/3	414/506	13.0	8.3	70.0	42.0	3.0	11.3	13.4	20
	575/60/3	517/633	11.5	7.4	53.0	n/a	1.9	9.3	11.2	15
070	208-230/60/1	187/253	47.0	30.1	145.0	58.0	5.9	36.0	43.5	70
	208-230/60/3	187/253	28.0	17.3	120.0	72.0	5.9	23.2	27.5	40
	460/60/3	414/506	15.0	9.6	70.0	42.0	3.0	12.6	15.0	20
	575/60/3	517/633	12.5	8.0	53.0	n/a	1.9	9.9	11.9	15

HACR circuit breaker in USA only
 * With optional high-static PSC motor

** With optional IntelliStart™

NOTE: High-static option not available on all model sizes.

05/21/13

Electrical Data cont.

5-Speed ECM Motor

Model	Rated Voltage	Voltage Min/Max	Compressor				Blower Motor FLA	Total Unit FLA	Min Circ Amp	Max Fuse/HACR
			MCC	RLA	LRA	LRA**				
015	208-230/60/1	187/253	9.2	5.9	29.0	n/a	4.1	10.0	11.5	15
	265/60/1	238/292	7.8	5.0	28.0	n/a	3.6	8.6	9.9	10/15
018	208-230/60/1	187/253	10.4	6.7	33.5	13.4	4.1	10.8	12.5	15
	265/60/1	238/292	8.7	5.6	28.0	n/a	3.6	9.2	10.6	15
023	208-230/60/1	187/253	21.0	13.5	58.3	23.3	4.1	17.6	21.0	30
	265/60/1	238/292	14.0	9.0	54.0	n/a	3.6	12.6	14.9	20
	208-230/60/3	187/253	11.0	7.1	55.0	33.0	4.1	11.2	13.0	20
	460/60/3	414/506	5.5	3.5	28.0	16.8	2.1	5.6	6.5	10/15
024	208-230/60/1	187/253	21.0	13.5	58.3	23.3	4.1	17.6	21.0	30
	265/60/1	238/292	14.0	9.0	54.0	n/a	3.6	12.6	14.9	20
	208-230/60/3	187/253	11.0	7.1	55.0	33.0	4.1	11.2	13.0	20
	460/60/3	414/506	5.5	3.5	28.0	16.8	2.1	5.6	6.5	10/15
030	208-230/60/1	187/253	22.0	14.1	73.0	29.2	4.1	18.2	21.7	35
	265/60/1	238/292	17.5	11.2	60.0	n/a	3.6	14.8	17.6	25
	208-230/60/3	187/253	13.9	8.9	58.0	34.8	4.1	13.0	15.2	20
	460/60/3	414/506	6.5	4.2	28.0	16.8	2.1	6.3	7.4	10/15
036	208-230/60/1	187/253	27.0	17.3	96.7	38.7	4.1	21.4	25.7	40
	265/60/1	238/292	19.0	12.2	72.0	n/a	3.6	15.8	18.9	30
	208-230/60/3	187/253	20.0	12.8	95.0	57.0	4.1	16.9	20.1	30
	460/60/3	414/506	10.0	6.4	45.0	27.0	2.1	8.5	10.1	15
041	208-230/60/1	187/253	31.0	20.0	115.0	46.0	7.6	27.6	32.6	50
	208-230/60/3	187/253	20.0	12.8	95.0	57.0	7.6	20.4	23.6	30
	460/60/3	414/506	10.0	6.4	45.0	27.0	4.0	10.4	12.0	15
042	208-230/60/1	187/253	31.0	20.0	115.0	46.0	7.6	27.6	32.6	50
	208-230/60/3	187/253	20.0	12.8	95.0	57.0	7.6	20.4	23.6	30
	460/60/3	414/506	10.0	6.4	45.0	27.0	4.0	10.4	12.0	15
048	208-230/60/1	187/253	32.0	21.0	115.0	46.0	7.6	28.6	33.9	50
	208-230/60/3	187/253	25.0	16.0	115.0	69.0	7.6	23.6	27.6	40
	460/60/3	414/506	12.0	7.7	50.0	30.0	4.0	11.7	13.6	20
060	208-230/60/1	187/253	41.0	26.3	150.0	60.0	7.6	33.9	40.5	60
	208-230/60/3	187/253	27.5	17.6	120.0	72.0	7.6	25.2	29.6	45
	460/60/3	414/506	13.0	8.3	70.0	42.0	4.0	12.3	14.4	25
070	208-230/60/1	187/253	47.0	30.1	145.0	58.0	7.6	37.7	45.2	70
	208-230/60/3	187/253	28.0	17.3	120.0	72.0	7.6	24.9	29.2	45
	460/60/3	414/506	15.0	9.6	70.0	42.0	4.0	13.6	16.0	25

HACR circuit breaker in USA only

** With optional IntelliStart™

05/21/13

Electrical Data cont.

Variable Speed ECM Motor

Model	Rated Voltage	Voltage Min/Max	Compressor				Blower Motor FLA	Total Unit FLA	Min Circ Amp	Max Fuse/HACR
			MCC	RLA	LRA	LRA**				
015	208-230/60/1	187/253	9.2	5.9	29.0	n/a	4.0	9.9	11.4	15
	265/60/1	238/292	7.8	5.0	28.0	n/a	4.1	9.1	10.3	15
018	208-230/60/1	187/253	10.4	6.7	33.5	13.4	4.0	10.7	12.4	15
	265/60/1	238/292	8.7	5.6	28.0	n/a	4.1	9.7	11.1	15
023	208-230/60/1	187/253	21.0	13.5	58.3	23.3	4.0	17.5	20.9	30
	265/60/1	238/292	14.0	9.0	54.0	n/a	4.1	13.1	15.4	20
	208-230/60/3	187/253	11.0	7.1	55.0	33.0	4.0	11.1	12.9	15
024	460/60/3	414/506	5.5	3.5	28.0	16.8	4.1	7.6	8.5	10/15
	208-230/60/1	187/253	21.0	13.5	58.3	23.3	4.0	17.5	20.9	30
	265/60/1	238/292	14.0	9.0	54.0	n/a	4.1	13.1	15.4	20
	208-230/60/3	187/253	11.0	7.1	55.0	33.0	4.0	11.1	12.9	15
030	460/60/3	414/506	5.5	3.5	28.0	16.8	4.1	7.6	8.5	10/15
	208-230/60/1	187/253	22.0	14.1	73.0	29.2	4.0	18.1	21.6	35
	265/60/1	238/292	17.5	11.2	60.0	n/a	4.1	15.3	18.1	25
	208-230/60/3	187/253	13.9	8.9	58.0	34.8	4.0	12.9	15.1	20
036	460/60/3	414/506	6.5	4.2	28.0	16.8	4.1	8.3	9.4	10/15
	208-230/60/1	187/253	27.0	17.3	96.7	38.7	4.0	21.3	25.6	40
	265/60/1	238/292	19.0	12.2	72.0	n/a	4.1	16.3	19.3	30
	208-230/60/3	187/253	20.0	12.8	95.0	57.0	4.0	16.8	20.0	30
041	460/60/3	414/506	10.0	6.4	45.0	27.0	4.1	10.5	12.1	15
	208-230/60/1	187/253	31.0	20.0	115.0	46.0	4.0	24.0	29.0	45
	208-230/60/3	187/253	20.0	12.8	95.0	57.0	4.0	16.8	20.0	30
	460/60/3	414/506	10.0	6.4	45.0	27.0	4.1	10.5	12.1	15
042	208-230/60/1	187/253	31.0	20.0	115.0	46.0	4.0	24.0	29.0	45
	208-230/60/3	187/253	20.0	12.8	95.0	57.0	4.0	16.8	20.0	30
	460/60/3	414/506	10.0	6.4	45.0	27.0	4.1	10.5	12.1	15
042*	208-230/60/1	187/253	31.0	20.0	115.0	46.0	7.0	27.0	32.0	50
	208-230/60/3	187/253	20.0	12.8	95.0	57.0	7.0	19.8	23.0	35
	460/60/3	414/506	10.0	6.4	45.0	27.0	6.9	13.3	14.9	20
048	208-230/60/1	187/253	32.0	21.0	115.0	46.0	4.0	25.0	30.3	50
	208-230/60/3	187/253	25.0	16.0	115.0	69.0	4.0	20.0	24.0	40
	460/60/3	414/506	12.0	7.7	50.0	30.0	4.1	11.8	13.7	20
048*	208-230/60/1	187/253	32.0	21.0	115.0	46.0	7.0	28.0	33.3	50
	208-230/60/3	187/253	25.0	16.0	115.0	69.0	7.0	23.0	27.0	40
	460/60/3	414/506	12.0	7.7	50.0	30.0	6.9	14.6	16.5	20
060	208-230/60/1	187/253	41.0	26.3	150.0	60.0	7.0	33.3	39.9	60
	208-230/60/3	187/253	27.5	17.6	120.0	72.0	7.0	24.6	29.0	45
	460/60/3	414/506	13.0	8.3	70.0	42.0	6.9	15.2	17.3	25
070	208-230/60/1	187/253	47.0	30.1	145.0	58.0	7.0	37.1	44.6	70
	208-230/60/3	187/253	28.0	17.3	120.0	72.0	7.0	24.9	29.4	45
	460/60/3	414/506	15.0	9.6	70.0	42.0	6.9	16.5	18.9	25

HACR circuit breaker in USA only

* With optional 1 HP ECM motor

** With optional IntelliStart™

05/21/13



CAUTION: When installing a unit with a variable speed ECM blower motor in 460/60/3 voltage, a neutral wire is required to allow proper unit operation.

Blower Performance Data cont.

Variable Speed ECM Motor

Model	Max esp	Airflow DIP Switch Settings												
		1	2	3	4	5	6	7	8	9	10	11	12	
015	0.50	300 L	400	500 M	600 H	700								
018	0.50	300	400 L	500	600 M	700 H	800							
023	0.50		400	500 L	600 M	700	800 H	900	1000	1100	1200			
024	0.50		400	500 L	600 M	700	800 H	900	1000	1100	1200			
030	0.50		400	500 L	600	700 M	800	900 H	1000	1100	1200			
036	0.50				600	700 L	800	900 M	1000	1100 H	1150	1225	1300	
041	0.50	650	750	850 L	950	1050 M	1150	1250	1325 H	1375	1475	1550	1600	
042	0.50	650	750	850 L	950	1050 M	1150	1250	1325 H	1375	1475	1550	1600	
042 w/1hp*	0.75	800 L	1000 M	1100	1300 H	1500	1600	1800						
048	0.50	650	750	850	950	1050 L	1150	1250 M	1325	1375	1475	1550 H	1600	
048 w/1hp*	0.75	800	1000 L	1100	1300 M	1500 H	1600	1800						
060	0.75	750	900	1000	1200 L	1400 M	1600	1700	1850 H	2000	2200	2300	2400	
070	0.75	800	950	1100 L	1300	1500	1750 M	1950	2100 H	2300				

Factory settings are at recommended L-M-H DIP switch locations. 11/10/09
 Shaded regions are recommended for best performance. It is acceptable to operate outside of this area as long as the WSHP operates within the guidelines of the Operating Limits table and Correction Factor tables.
 Lowest and Highest DIP switch settings are assumed to be L and H respectively.
 CFM is controlled within ±5% up to the maximum esp.
 Max esp includes allowance for wet coil and standard filter

Blower Performance Data cont.

Setting Blower Speed - Variable Speed ECM

The ABC board's Yellow Config LED will flash the current variable speed ECM blower speed selections for low, med, and high continuously with a short pause in between. The speeds can also be confirmed with the AID Tool under the Setup/ECM Setup screen. The variable speed ECM blower motor speeds can be field adjusted with or without using an AID Tool.

Variable Speed ECM Setup without an AID Tool

The blower speeds for Low (G only), Med (Y1), and High (Y2/Aux) can be adjusted directly at the Aurora ABC board which utilizes the push button (SW1) on the ABC board. This procedure is outlined in the Variable Speed ECM Configuration Mode portion of the Aurora 'Base' Control System section.

Variable Speed ECM Setup with an AID Tool

A much easier method utilizes the AID Tool to change the airflow using the procedure below. First navigate to the Setup screen and then select ECM Setup. This screen displays the current variable speed ECM settings. It allows the technician to enter the setup screens to change the variable speed ECM settings. Change the highlighted item using the ◀ and ▶ buttons and then press the ◻ button to select the item.

Variable Speed ECM Setup with an AID Tool cont.

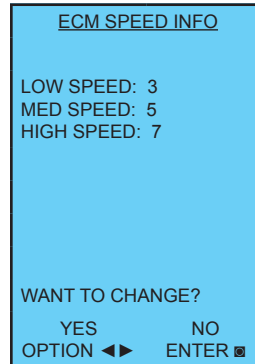

Selecting YES will enter variable speed ECM speed setup, while selecting NO will return to the previous screen.

Variable Speed ECM Speed Setup - These

screens allow the technician to select the low, medium, and high blower speed for the variable speed ECM blower motor. Change the highlighted item using the ▲ and ▼ buttons. Press the ◻ button to select the speed.

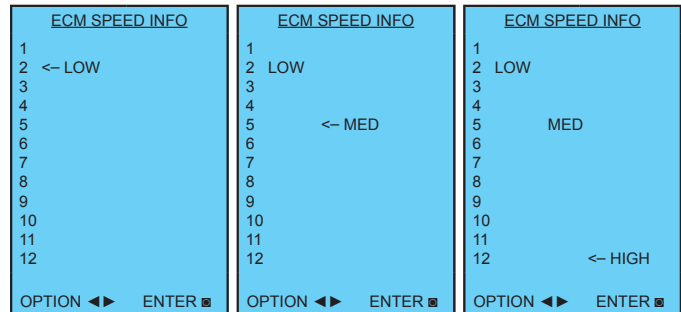

After the high speed setting is selected the AID Tool will automatically transfer back to the ECM Setup screen.

Selection Example

To achieve optimal performance, proper selection of each heat pump is essential. A building load program should be used to determine the heating and cooling load of each zone. A computer software selection program can then be used to develop an accurate and complete heat pump schedule. Software can be obtained from your local York representative.

While a computer software program is the easiest and most accurate method to size and select equipment, however, selection can still be accomplished manually using this manual and the following selection procedure. Sizing so that the actual sensible capacity of the equipment will satisfy the sensible capacity of the zone is the recommended method for best results.

Boiler/Tower Application

Typical boiler/tower application will result in entering water temperatures of 60-90°F with 70°F for heating and 90°F for cooling. Water to refrigerant insulation option would not be required. Flow rates are 2.5 to 3 gpm per ton with 2.5 gpm per ton often representing an economical design point.

Geothermal Application

Typical geothermal application can result in a wide entering water temperature range of 30-100°F. Typically minimum heating entering water temperatures can range from 30 to 50°F depending upon loop type and geographical location. Cooling performance should be calculated using a maximum loop temperature of 100°F in most loop applications. Water flow is typically 2.5 to 3 gpm per ton with 3 gpm per ton recommended with the more extreme loop temperatures. PLEASE NOTE THAT WATER COIL INSULATION OPTION SHOULD BE SELECTED WHEN ENTERING WATER TEMPERATURES ARE EXPECTED TO BE BELOW 45-50°F.

Geothermal Selection Example

Step 1: Determine the actual heating and cooling loads at the desired dry bulb and wet bulb conditions.

Step 2: Obtain the following design parameters: Entering water temperature, water flow rate in gpm, airflow in cfm, water flow pressure drop and design wet and dry bulb temperatures. Airflow, cfm, should be between 300 and 450 cfm per ton. Unit water pressure drop should be kept as close as possible to each other to make water balancing easier. Go to the appropriate tables and find the proper indicated water flow and water temperature.

Step 3: Select a unit based on total and sensible cooling conditions. Select a unit which is closest to, but no larger than, the actual cooling load.

Step 4: Enter tables at the design water flow and water temperature. Read the total and sensible cooling capacities (**NOTE:** interpolation is permissible, extrapolation is not).

Step 5: Read the heating capacity. If it exceeds the design criteria it is acceptable. It is quite normal for water source heat pumps to be selected on cooling capacity only since the heating output is usually greater than the cooling capacity.

Step 6: Determine the correction factors associated with the variable factors of dry bulb and wet bulb.

Corrected Total Cooling = tabulated total cooling x wet bulb correction.

Corrected Sensible Cooling = tabulated sensible cooling x wet/dry bulb correction.

Step 7: Compare the corrected capacities to the load requirements. Normally if the capacities are within 10% of the loads, the equipment is acceptable. It is better to undersize than oversize, as undersizing improves humidity control, reduces sound levels and extends the life of the equipment.

Step 8: When complete, calculate water temperature rise and assess the selection. If the units selected are not within 10% of the load calculations, then review what effect changing the gpm, water temperature and/or airflow and air temperature would have on the corrected capacities. If the desired capacity cannot be achieved, select the next larger or smaller unit and repeat the procedure. Remember, when in doubt, undersize slightly for best performance.

Example Equipment Selection - Cooling

1. Load Determination:

Assume we have determined that the appropriate cooling load at the desired dry bulb 80°F and wet bulb 65°F conditions is as follows:

Total Cooling.....	56,500 Btu/h
Sensible Cooling.....	36,300 Btu/h
Entering Air Temp	75°F Dry Bulb / 60°F Wet Bulb

2. Design Conditions:

Similarly, we have also obtained the following design parameters:
Entering Water Temp90°F
Water Flow (Based upon 10°F rise in temp.) 15.0 gpm
Airflow Required 1,850 cfm @ 0.2 in. wg.

Selection Example cont.

3, 4 & 5. HP Selection:

After making our preliminary selection (YG*060 ECM), we enter the tables at design water flow and water temperature and read Total Cooling, Sens. Cooling and Heat of Rej. capacities:

Total Cooling.....60,500 Btu/h
 Sensible Cooling.....45,000 Btu/h
 Heat of Rejection.....75,500 Btu/h

6 & 7. Entering Air and Airflow Corrections:

Next, we determine our correction factors. (Refer to Correction Factor Tables - Airflow and Entering Air correction tables — using 1,850 cfm. or 1,850÷2,000 nom. = 92.5%).

Corrected Total Cooling = 60,500 x 0.990 x 0.967 = 57,918
 Corrected Sens Cooling = 45,000 x 0.956 x 0.881 = 37,900
 Corrected Heat of Rejection = 75,500 x 0.987 x 0.972 = 72,432

$$HR = 500 \times \text{gpm} \times (T_{in} - T_{out})$$

$$\frac{HR}{500 \times \text{gpm}} = (T_{in} - T_{out}) \text{ or } \Delta T \text{ Rise}$$

$$\frac{72,432}{500 \times 15} = 9.65 \text{ } ^\circ\text{F Rise}$$

8. Water Temperature Rise Calculation & Assessment:

Note: 500 = parameters for water & 485 = parameters for antifreeze solutions to 30% weight.

When we compare the Corrected Total Cooling and Corrected Sensible Cooling figures with our load requirements stated in Step 1, we discover that our selection is within +10% of our sensible load requirement. Further more, we see that our Corrected Total Cooling figure is within 1,000 Btu/h of the actual indicated load.

Antifreeze Corrections

Catalog performance can be corrected for antifreeze use. Please use the following table and note the example given.

Antifreeze Type	Antifreeze % by wt	Cooling Capacity	Heating Capacity	Pressure Drop
EWT - degF [DegC]		90 [32.2]	30 [-1.1]	30 [-1.1]
Water	0	1.000	1.000	1.000
Ethylene Glycol	10	0.991	0.973	1.075
	20	0.979	0.943	1.163
	30	0.965	0.917	1.225
	40	0.955	0.890	1.324
	50	0.943	0.865	1.419
Propylene Glycol	10	0.981	0.958	1.130
	20	0.969	0.913	1.270
	30	0.950	0.854	1.433
	40	0.937	0.813	1.614
	50	0.922	0.770	1.816
Ethanol	10	0.991	0.927	1.242
	20	0.972	0.887	1.343
	30	0.947	0.856	1.383
	40	0.930	0.815	1.523
	50	0.911	0.779	1.639
Methanol	10	0.986	0.957	1.127
	20	0.970	0.924	1.197
	30	0.951	0.895	1.235
	40	0.936	0.863	1.323
	50	0.920	0.833	1.399

Warning: Gray area represents antifreeze concentrations greater than 35% by weight and should be avoided due to the extreme performance penalty they represent.

Antifreeze Correction Example

Antifreeze solution is Propylene Glycol 20% by weight. Determine the corrected heating and cooling performance at 30°F and 90°F respectively as well as pressure drop at 30°F for a LX Ultra Series YGS*024-PSC.

The corrected cooling capacity at 90°F would be: 24,500 Btu/h x 0.969 = 23,740 Btu/h

The corrected heating capacity at 30°F would be: 19,000 Btu/h x 0.913 = 17,347 Btu/h

The corrected pressure drop at 30°F and 6 gpm would be: 10.5 ft. hd x 1.270 = 13.34 ft. hd.

Reference Calculations

Heating Calculations:	Cooling Calculations:
$LWT = EWT - \frac{HE}{GPM \times 500}$	$LWT = EWT + \frac{HR}{GPM \times 500}$
$LAT = EAT + \frac{HC}{CFM \times 1.08}$	$LAT (DB) = EAT (DB) - \frac{SC}{CFM \times 1.08}$
$TH = HC + HWC$	$LC = TC - SC$
	$S/T = \frac{SC}{TC}$

Legend and Notes

ABBREVIATIONS AND DEFINITIONS:

- | | |
|--|---|
| CFM = airflow, cubic feet/minute | HE = total heat of extraction, MBTUH |
| EWT = entering water temperature, Fahrenheit | HWC = hot water generator capacity, MBTUH |
| GPM = water flow in gallons/minute | EER = Energy Efficient Ratio |
| WPD = water pressure drop, PSI and feet of water | = BTU output/Watt input |
| EAT = entering air temperature, Fahrenheit (dry bulb/wet bulb) | COP = Coefficient of Performance |
| HC = air heating capacity, MBTUH | = BTU output/BTU input |
| TC = total cooling capacity, MBTUH | LWT = leaving water temperature, °F |
| SC = sensible cooling capacity, MBTUH | LAT = leaving air temperature, °F |
| KW = total power unit input, kilowatts | TH = total heating capacity, MBTUH |
| HR = total heat of rejection, MBTUH | LC = latent cooling capacity, MBTUH |
| | S/T = sensible to total cooling ratio |

Notes (Refer to Performance Data tables)

- Performance ratings are based on 80°F DB / 67°F WB EAT for cooling and 70°F DB EAT for heating.
- Three flow rates are shown for each unit. The lowest flow rate shown is used for geothermal open loop/well water systems with a minimum of 50°F EWT. The middle flow rate shown is the minimum geothermal closed loop flow rate. The highest flow rate shown is optimum for geothermal closed loop systems and the suggested flow rate for boiler/tower applications.
- The hot water generator numbers are based on a flow rate of 0.4 GPM/ton of rated capacity with an EWT of 90°F.
- Entering water temperatures below 40°F assumes 15% antifreeze solution.
- For non-standard EAT conditions, apply the appropriate correction factors on (Refer to Correction Factor Tables).
- Interpolation between EWT, GPM and CFM data is permissible.

Operating Limits

Operating Limits	Cooling		Heating	
	(°F)	(°C)	(°F)	(°C)
Air Limits				
Min. Ambient Air	45	7.2	45	7.2
Rated Ambient Air	80	26.7	70	21.1
Max. Ambient Air	100	37.8	85	29.4
Min. Entering Air	50	10.0	40	4.4
Rated Entering Air db/wb	80.6/66.2	27/19	68	20.0
Max. Entering Air db/wb	110/83	43/28.3	80	26.7
Water Limits				
Min. Entering Water	30	-1.1	20	-6.7
Normal Entering Water	50-110	10-43.3	30-70	-1.1
Max. Entering Water	120	48.9	90	32.2

NOTE: Minimum/maximum limits are only for start-up conditions, and are meant for bringing the space up to occupancy temperature. Units are not designed to operate at the minimum/maximum conditions on a regular basis. The operating limits are dependent upon three primary factors: 1) water temperature, 2) return air temperature, and 3) ambient temperature. When any of the factors are at the minimum or maximum levels, the other two factors must be at the normal level for proper and reliable unit operation.

Correction Factors

Cooling Capacity Corrections

Entering Air WB °F	Total Clg Cap	Sensible Cooling Capacity Multipliers - Entering DB °F										Power Input	Heat of Rejection
		60	65	70	75	80	80.6	85	90	95	100		
55	0.898	0.723	0.866	1.048	1.185	*	*	*	*	*	*	0.985	0.913
60	0.912		0.632	0.880	1.078	1.244	1.260	*	*	*	*	0.994	0.927
65	0.967			0.694	0.881	1.079	1.085	1.270	*	*	*	0.997	0.972
66.2	0.983			0.655	0.842	1.040	1.060	1.232	*	*	*	0.999	0.986
67	1.000			0.616	0.806	1.000	1.023	1.193	1.330	*	*	1.000	1.000
70	1.053				0.693	0.879	0.900	1.075	1.250	1.404	*	1.003	1.044
75	1.168					0.687	0.715	0.875	1.040	1.261	1.476	1.007	1.141

NOTE: * Sensible capacity equals total capacity at conditions shown.

11/10/09

Heating Corrections

Ent Air DB °F	Htg Cap	Power	Heat of Ext
45	1.062	0.739	1.158
50	1.050	0.790	1.130
55	1.037	0.842	1.096
60	1.025	0.893	1.064
65	1.012	0.945	1.030
68	1.005	0.976	1.012
70	1.000	1.000	1.000
75	0.987	1.048	0.970
80	0.975	1.099	0.930

11/10/09

Airflow Corrections

Airflow		Cooling				Heating		
cfm Per Ton of Clg	% of Nominal	Total Cap	Sens Cap	Power	Heat of Rej	Htg Cap	Power	Heat of Ext
240	60	0.922	0.786	0.910	0.920	0.943	1.150	0.893
275	69	0.944	0.827	0.924	0.940	0.958	1.105	0.922
300	75	0.959	0.860	0.937	0.955	0.968	1.078	0.942
325	81	0.971	0.894	0.950	0.967	0.977	1.053	0.959
350	88	0.982	0.929	0.964	0.978	0.985	1.031	0.973
375	94	0.992	0.965	0.982	0.990	0.993	1.014	0.988
400	100	1.000	1.000	1.000	1.000	1.000	1.000	1.000
425	106	1.007	1.034	1.020	1.010	1.007	0.990	1.011
450	113	1.012	1.065	1.042	1.018	1.013	0.983	1.020
475	119	1.017	1.093	1.066	1.026	1.018	0.980	1.028
500	125	1.019	1.117	1.092	1.033	1.023	0.978	1.034
520	130	1.020	1.132	1.113	1.038	1.026	0.975	1.038

11/10/09

Pressure Drop

Model	gpm	Pressure Drop (psi)				
		30°F	50°F	70°F	90°F	110°F
009	1.5	2.0	1.7	1.4	1.3	1.0
	2.0	3.8	3.2	2.8	2.3	1.8
	3.0	7.2	6.0	5.1	4.5	4.0
	4.0	12.0	10.0	9.0	7.5	6.0
012	1.5	1.1	1.0	0.9	0.8	0.7
	2.5	2.5	2.3	2.1	1.8	1.5
	3.5	3.9	3.6	3.2	2.7	2.3
	4.5	5.3	4.9	4.5	3.8	3.5
015	2.0	0.6	0.5	0.5	0.4	0.4
	3.0	1.1	1.0	0.9	0.8	0.6
	4.0	1.9	1.8	1.6	1.5	1.3
	5.0	3.3	3.2	3.0	2.9	2.7
018	3.0	1.1	1.0	0.9	0.8	0.6
	4.0	1.9	1.8	1.6	1.5	1.3
	5.0	3.3	3.2	3.0	2.9	2.7
	6.0	4.5	4.4	4.3	4.1	4.0
023	3.0	1.1	1.0	0.9	0.8	0.6
	4.5	2.4	2.2	2.1	2.0	1.9
	6.0	4.5	4.4	4.3	4.1	4.0
	8.0	6.7	6.6	6.5	6.3	6.2
024	3.0	1.1	1.0	0.9	0.8	0.6
	4.5	2.4	2.2	2.1	2.0	1.9
	6.0	4.5	4.4	4.3	4.1	4.0
	8.0	6.7	6.6	6.5	6.3	6.2
030	4.0	0.9	0.8	0.7	0.6	0.5
	6.0	1.9	1.8	1.7	1.6	1.5
	8.0	3.7	3.6	3.5	3.4	3.3
	10.0	4.8	4.7	4.6	4.5	4.4
036	5.0	1.4	1.1	0.9	0.7	0.5
	7.0	2.5	2.3	2.1	1.8	1.6
	9.0	6.0	5.8	5.5	5.3	5.1
	12.0	6.6	6.4	6.2	6.0	5.7
041	5.0	1.5	1.2	0.9	0.5	0.4
	8.0	3.4	3.1	2.8	2.5	2.1
	11.0	7.9	7.5	7.2	6.9	6.6
	14.0	9.1	8.8	8.5	8.2	7.9
042	5.0	1.5	1.2	0.9	0.5	0.4
	8.0	3.4	3.1	2.8	2.5	2.1
	11.0	7.9	7.5	7.2	6.9	6.6
	14.0	9.1	8.8	8.5	8.2	7.9
048	6.0	2.0	1.7	1.3	1.0	0.6
	9.0	4.2	3.8	3.5	3.1	2.7
	12.0	6.7	6.3	5.9	5.6	5.2
	16.0	11.5	11.2	10.8	10.5	10.1
060	9.0	3.6	3.3	3.0	2.7	2.3
	12.0	6.1	5.8	5.5	5.2	4.8
	15.0	9.6	9.2	8.9	8.6	8.3
	20.0	15.5	15.2	14.9	14.5	14.2
070	12.0	4.1	3.6	3.2	2.8	2.3
	15.0	5.9	5.0	4.6	4.1	3.7
	18.0	8.8	8.4	7.9	7.5	7.1
	24.0	12.9	12.0	11.5	11.1	10.7

7/6/10

Valve	gpm	Cv	Pressure Drop (psi)
1/2 in.	1.5	9.6	0.02
	2.0	9.7	0.04
	3.0	9.9	0.09
	4.0	10.1	0.16
1/2 in.	1.5	9.6	0.02
	2.5	9.8	0.06
	3.5	10.0	0.12
	4.5	10.2	0.19
1/2 in.	2.0	9.7	0.04
	3.0	9.9	0.09
	4.0	10.1	0.16
	5.0	10.4	0.23
1/2 in.	3.0	9.9	0.09
	4.0	10.1	0.16
	5.0	10.4	0.23
	6.0	10.6	0.32
3/4 in.	3.0	9.9	0.09
	4.5	10.2	0.19
	6.0	10.6	0.32
	8.0	11.0	0.53
3/4 in.	3.0	9.9	0.09
	4.5	10.2	0.19
	6.0	10.6	0.32
	8.0	11.0	0.53
3/4 in.	4.0	10.1	0.16
	6.0	10.6	0.32
	8.0	11.0	0.53
	10.0	11.5	0.76
3/4 in.	5.0	10.4	0.23
	7.0	10.8	0.42
	9.0	11.2	0.64
	12.0	11.9	1.02
3/4 in.	5.0	10.4	0.23
	8.0	11.0	0.53
	11.0	11.7	0.89
	14.0	12.3	1.29
1 in.	5.0	15.9	0.10
	8.0	16.6	0.23
	11.0	17.2	0.41
	14.0	17.9	0.61
1 in.	6.0	16.1	0.14
	9.0	16.8	0.29
	12.0	17.4	0.47
	16.0	18.3	0.76
1 in.	9.0	16.8	0.29
	12.0	17.4	0.47
	15.0	18.1	0.69
	20.0	19.2	1.09
1 in.	12.0	17.4	0.47
	15.0	18.1	0.69
	18.0	18.7	0.92
	24.0	20.1	1.43

11/10/09

YG009 - Performance Data

Single Speed PSC (350 cfm)

EWT °F	Flow gpm	WPD		HEATING - EAT 70°F					COOLING - EAT 80/67°F					
		psi	ft. hd.	HC MBtu/h	Power kW	HE MBtu/h	LAT °F	COP	TC MBtu/h	SC MBtu/h	S/T Ratio	Power kW	HR MBtu/h	EER
20	1.5	2.2	5.1	Operation not recommended					Operation not recommended					
	2.0	4.2	9.7	Operation not recommended					Operation not recommended					
	3.0	7.5	17.3	6.0	0.65	3.8	83.9	2.71	Operation not recommended					
30	1.5	2.0	4.6	Operation not recommended					Operation not recommended					
	2.0	3.8	8.8	6.1	0.64	3.9	84.1	2.79	11.2	7.5	0.67	0.52	13.0	21.7
	3.0	7.2	16.6	6.9	0.67	4.6	86.2	3.01	11.4	7.7	0.67	0.49	13.0	23.4
40	1.5	1.9	4.4	Operation not recommended					Operation not recommended					
	2.0	3.5	8.1	6.9	0.67	4.6	86.3	3.03	11.1	7.6	0.68	0.55	13.0	20.3
	3.0	6.5	15.0	7.5	0.69	5.2	87.9	3.21	11.2	7.7	0.68	0.52	13.0	21.6
50	1.5	1.7	3.9	7.6	0.69	5.2	88.1	3.23	11.1	7.6	0.69	0.59	13.1	18.6
	2.0	3.2	7.4	7.8	0.69	5.4	88.6	3.29	11.1	7.6	0.69	0.58	13.1	19.0
	3.0	6.0	13.8	8.2	0.70	5.8	89.6	3.41	11.1	7.6	0.69	0.56	13.0	19.9
60	1.5	1.6	3.6	8.7	0.72	6.2	90.9	3.52	10.4	7.3	0.70	0.66	12.6	15.9
	2.0	3.0	6.9	8.9	0.72	6.4	91.5	3.59	10.5	7.3	0.70	0.64	12.6	16.3
	3.0	5.6	12.8	9.3	0.73	6.8	92.7	3.74	10.5	7.4	0.70	0.61	12.6	17.2
70	1.5	1.4	3.2	9.7	0.75	7.1	93.7	3.79	9.8	7.0	0.71	0.72	12.2	13.6
	2.0	2.8	6.5	10.0	0.75	7.4	94.4	3.88	9.8	7.0	0.71	0.70	12.2	14.0
	3.0	5.1	11.9	10.5	0.76	7.9	95.8	4.05	10.0	7.2	0.72	0.67	12.3	14.9
80	1.5	1.4	3.1	11.2	0.77	8.5	97.5	4.27	9.0	6.8	0.75	0.80	11.7	11.3
	2.0	2.6	5.9	11.4	0.77	8.8	98.1	4.32	9.1	6.8	0.75	0.76	11.7	12.0
	3.0	4.8	11.0	11.8	0.78	9.1	99.1	4.42	9.3	7.0	0.75	0.74	11.8	12.6
90	1.5	1.3	3.0	12.6	0.78	9.9	101.4	4.74	8.3	6.6	0.79	0.87	11.3	9.5
	2.0	2.3	5.3	12.8	0.79	10.1	101.9	4.75	8.4	6.7	0.79	0.83	11.3	10.2
	3.0	4.5	10.4	13.0	0.80	10.3	102.4	4.76	8.6	6.8	0.79	0.80	11.3	10.7
100	1.5	1.3	2.9	Operation not recommended					Operation not recommended					
	2.0	2.1	4.7	Operation not recommended					7.9	6.5	0.83	0.91	11.0	8.6
	3.0	4.3	9.8	Operation not recommended					8.0	6.6	0.82	0.88	11.0	9.1
110	1.5	1.0	2.3	Operation not recommended					Operation not recommended					
	2.0	1.8	4.2	Operation not recommended					7.2	6.2	0.86	0.99	10.6	7.3
	3.0	4.0	9.2	Operation not recommended					7.4	6.3	0.86	0.96	10.6	7.7
120	1.5	0.9	2.1	Operation not recommended					Operation not recommended					
	2.0	1.7	3.9	Operation not recommended					6.2	5.6	0.89	1.07	9.9	5.8
	3.0	3.8	8.8	Operation not recommended					6.4	5.6	0.89	1.04	9.9	6.1

11/10/09

YG012 - Performance Data

Single Speed PSC (400 cfm)

EWT °F	Flow gpm	WPD		HEATING - EAT 70°F					COOLING - EAT 80/67°F					
		psi	ft. hd.	HC MBtu/h	Power kW	HE MBtu/h	LAT °F	COP	TC MBtu/h	SC MBtu/h	S/T Ratio	Power kW	HR MBtu/h	EER
20	1.5	1.2	2.8	Operation not recommended					Operation not recommended					
	2.5	2.6	6.0	Operation not recommended					Operation not recommended					
	3.5	4.1	9.5	7.2	0.81	4.4	84.7	2.61	Operation not recommended					
30	1.5	1.1	2.5	Operation not recommended					Operation not recommended					
	2.5	2.5	5.8	8.6	0.81	5.9	88.0	3.13	15.7	10.0	0.64	0.47	17.3	33.5
	3.5	3.9	9.0	8.9	0.83	6.1	88.6	3.14	15.9	10.2	0.64	0.44	17.4	36.1
40	1.5	1.1	2.4	Operation not recommended					Operation not recommended					
	2.5	2.4	5.5	9.6	0.83	6.8	90.2	3.39	15.3	10.0	0.65	0.53	17.1	28.6
	3.5	3.8	8.7	10.0	0.85	7.1	91.0	3.45	15.5	10.1	0.65	0.50	17.1	31.2
50	1.5	1.0	2.3	10.3	0.85	7.4	91.8	3.55	14.7	10.0	0.68	0.65	16.9	22.6
	2.5	2.3	5.3	10.7	0.86	7.7	92.7	3.65	14.9	10.0	0.67	0.60	16.9	24.8
	3.5	3.6	8.3	11.0	0.86	8.1	93.5	3.75	15.0	9.9	0.66	0.55	16.9	27.3
60	1.5	1.0	2.2	11.5	0.87	8.5	94.5	3.86	14.2	9.7	0.68	0.73	16.7	19.5
	2.5	2.2	5.1	11.9	0.88	8.9	95.5	3.96	14.4	9.7	0.68	0.68	16.7	21.1
	3.5	3.4	7.9	12.4	0.89	9.3	96.6	4.07	14.5	9.8	0.67	0.63	16.6	23.0
70	1.5	0.9	2.1	12.6	0.89	9.6	97.2	4.15	13.7	9.4	0.69	0.81	16.5	16.9
	2.5	2.1	4.9	13.2	0.91	10.1	98.4	4.26	13.9	9.5	0.69	0.76	16.4	18.2
	3.5	3.2	7.4	13.7	0.92	10.6	99.7	4.36	14.0	9.6	0.69	0.71	16.4	19.7
80	1.5	0.9	2.0	14.2	0.91	11.0	100.8	4.54	13.0	9.2	0.70	0.89	16.1	14.6
	2.5	2.0	4.5	14.6	0.93	11.4	101.7	4.60	13.2	9.3	0.70	0.85	16.1	15.5
	3.5	2.9	6.7	15.0	0.94	11.7	102.6	4.66	13.4	9.4	0.70	0.83	16.2	16.2
90	1.5	0.8	1.8	15.7	0.94	12.5	104.4	4.92	12.4	8.9	0.72	1.02	15.8	12.1
	2.5	1.8	4.2	16.0	0.95	12.7	104.9	4.93	12.5	9.0	0.72	0.97	15.9	12.9
	3.5	2.7	6.2	16.2	0.96	12.9	105.5	4.95	12.8	9.2	0.71	0.94	16.0	13.6
100	1.5	0.8	1.7	Operation not recommended					Operation not recommended					
	2.5	1.7	3.8	Operation not recommended					12.2	9.0	0.73	1.11	16.0	11.0
	3.5	2.5	5.8	Operation not recommended					12.4	9.0	0.73	1.07	16.1	11.6
110	1.5	0.7	1.6	Operation not recommended					Operation not recommended					
	2.5	1.5	3.5	Operation not recommended					11.8	8.8	0.75	1.23	16.0	9.5
	3.5	2.3	5.3	Operation not recommended					12.0	8.9	0.74	1.20	16.1	10.0
120	1.5	0.7	1.5	Operation not recommended					Operation not recommended					
	2.5	1.4	3.1	Operation not recommended					11.3	8.6	0.76	1.34	15.8	8.4
	3.5	2.1	4.9	Operation not recommended					11.5	8.7	0.76	1.30	15.9	8.8

YG015 - Performance Data

Single Speed PSC (500 cfm)

EWT °F	Flow gpm	WPD		HEATING - EAT 70°F						COOLING - EAT 80/67°F						
		psi	ft. hd.	HC MBtu/h	Power kW	HE MBtu/h	LAT °F	COP	HWC MBtu/h	TC MBtu/h	SC MBtu/h	S/T Ratio	Power kW	HR MBtu/h	EER	HWC MBtu/h
20	2.0	0.6	1.4	Operation not recommended						Operation not recommended						
	3.0	1.2	2.8	Operation not recommended						Operation not recommended						
	4.0	2.0	4.6	10.0	1.00	6.6	86.5	2.93	1.2	Operation not recommended						
30	2.0	0.6	1.4	Operation not recommended						Operation not recommended						
	3.0	1.1	2.6	11.0	1.04	7.4	88.3	3.09	1.3	14.5	9.8	0.68	0.71	16.9	20.3	---
	4.0	1.9	4.4	11.0	1.00	7.6	88.4	3.22	1.3	14.7	10.0	0.68	0.67	17.0	21.9	---
40	2.0	0.6	1.3	Operation not recommended						Operation not recommended						
	3.0	1.1	2.5	12.1	1.05	8.5	90.4	3.37	1.3	15.6	10.6	0.68	0.77	18.3	20.2	---
	4.0	1.8	4.3	12.4	1.04	8.8	90.9	3.50	1.3	15.9	10.8	0.68	0.74	18.4	21.4	---
50	2.0	0.5	1.2	13.0	1.06	9.4	92.1	3.59	1.4	16.5	11.3	0.68	0.85	19.4	19.4	0.8
	3.0	1.0	2.3	13.4	1.07	9.7	92.7	3.67	1.4	16.8	11.4	0.68	0.83	19.6	20.2	0.8
	4.0	1.8	4.1	13.7	1.07	10.1	93.4	3.75	1.5	17.0	11.5	0.68	0.81	19.8	21.0	0.8
60	2.0	0.5	1.2	14.4	1.07	10.7	94.6	3.93	1.6	15.7	10.9	0.69	0.92	18.8	17.2	0.9
	3.0	0.9	2.1	14.8	1.08	11.1	95.4	4.03	1.6	16.0	11.0	0.69	0.89	19.0	18.0	0.9
	4.0	1.7	3.9	15.3	1.09	11.5	96.2	4.12	1.7	16.2	11.1	0.68	0.86	19.1	18.9	0.8
70	2.0	0.5	1.1	15.7	1.08	12.0	97.1	4.26	1.8	14.9	10.5	0.70	0.98	18.2	15.2	1.1
	3.0	0.8	1.9	16.3	1.09	12.5	98.1	4.37	1.8	15.2	10.6	0.70	0.94	18.4	16.1	1.1
	4.0	1.6	3.7	16.8	1.10	13.1	99.1	4.48	1.8	15.4	10.6	0.69	0.90	18.5	17.1	1.0
80	2.0	0.5	1.1	17.6	1.10	13.8	100.5	4.69	2.0	14.2	10.2	0.72	1.03	17.7	13.7	1.4
	3.0	0.8	1.8	18.0	1.11	14.2	101.3	4.75	2.0	14.4	10.3	0.71	0.99	17.8	14.6	1.3
	4.0	1.5	3.6	18.4	1.12	14.6	102.1	4.81	2.1	14.7	10.4	0.71	0.96	17.9	15.3	1.3
90	2.0	0.4	1.0	19.4	1.11	15.6	103.9	5.12	2.3	13.4	9.9	0.74	1.09	17.1	12.3	1.8
	3.0	0.7	1.6	19.7	1.13	15.9	104.5	5.13	2.3	13.6	10.0	0.73	1.04	17.2	13.1	1.7
	4.0	1.5	3.4	20.0	1.14	16.1	105.0	5.14	2.3	13.9	10.1	0.73	1.01	17.3	13.8	1.6
100	2.0	0.4	0.9	Operation not recommended						Operation not recommended						
	3.0	0.6	1.4	Operation not recommended						12.8	9.7	0.76	1.16	16.7	11.0	2.1
	4.0	1.4	3.2	Operation not recommended						13.0	9.8	0.76	1.13	16.8	11.5	1.9
110	2.0	0.4	0.9	Operation not recommended						Operation not recommended						
	3.0	0.5	1.2	Operation not recommended						11.8	9.4	0.80	1.27	16.1	9.2	2.7
	4.0	1.3	3.0	Operation not recommended						12.0	9.5	0.79	1.24	16.2	9.7	2.5
120	2.0	0.4	0.9	Operation not recommended						Operation not recommended						
	3.0	0.5	1.1	Operation not recommended						10.8	9.1	0.84	1.41	15.6	7.6	3.3
	4.0	1.2	2.9	Operation not recommended						11.0	9.2	0.84	1.37	15.7	8.0	3.0

11/10/09

YG018 - Performance Data

Single Speed PSC (600 cfm)

EWT °F	Flow gpm	WPD		HEATING - EAT 70°F						COOLING - EAT 80/67°F						
		psi	ft. hd.	HC MBtu/h	Power kW	HE MBtu/h	LAT °F	COP	HWC MBtu/h	TC MBtu/h	SC MBtu/h	S/T Ratio	Power kW	HR MBtu/h	EER	HWC MBtu/h
20	3.0	1.2	2.8	Operation not recommended						Operation not recommended						
	4.0	2.0	4.6	Operation not recommended						Operation not recommended						
	5.0	3.4	7.8	13.0	1.21	8.9	88.1	3.15	1.4							
30	3.0	1.1	2.6	Operation not recommended						Operation not recommended						
	4.0	1.9	4.4	14.5	1.29	10.1	90.3	3.29	1.5	18.2	11.8	0.65	0.86	21.1	21.0	---
	5.0	3.3	7.6	14.9	1.31	10.4	91.0	3.33	1.5	18.4	12.0	0.65	0.81	21.2	22.7	---
40	3.0	1.1	2.5	Operation not recommended						Operation not recommended						
	4.0	1.8	4.3	15.7	1.34	11.1	92.2	3.43	1.6	19.1	12.4	0.65	0.92	22.2	20.8	---
	5.0	3.2	7.5	16.5	1.37	11.8	93.4	3.52	1.6	19.4	12.6	0.65	0.89	22.4	21.9	---
50	3.0	1.0	2.3	16.0	1.36	11.4	92.7	3.45	1.7	19.7	12.8	0.65	0.98	23.0	20.1	0.9
	4.0	1.8	4.1	17.0	1.40	12.2	94.2	3.57	1.7	20.0	13.0	0.65	0.97	23.3	20.6	0.9
	5.0	3.2	7.3	18.0	1.43	13.1	95.8	3.69	1.8	20.3	13.1	0.65	0.96	23.6	21.1	0.9
60	3.0	0.9	2.1	17.5	1.43	12.6	95.0	3.60	1.9	18.7	12.4	0.66	1.07	22.3	17.6	1.1
	4.0	1.7	3.9	18.5	1.45	13.5	96.5	3.73	1.9	18.9	12.6	0.67	1.06	22.5	17.9	1.1
	5.0	3.1	7.1	19.5	1.48	14.5	98.1	3.86	2.0	19.2	12.8	0.67	1.05	22.7	18.3	1.0
70	3.0	0.8	1.9	19.0	1.49	13.9	97.3	3.74	2.1	17.7	12.0	0.68	1.15	21.6	15.4	1.3
	4.0	1.6	3.7	20.0	1.51	14.8	98.9	3.88	2.1	17.9	12.3	0.69	1.14	21.7	15.7	1.3
	5.0	3.0	6.9	21.0	1.53	15.8	100.4	4.02	2.2	18.0	12.5	0.69	1.13	21.9	15.9	1.2
80	3.0	0.8	1.8	21.9	1.56	16.5	101.7	4.10	2.4	16.6	11.4	0.69	1.36	21.2	12.2	1.7
	4.0	1.5	3.6	22.6	1.58	17.2	102.8	4.17	2.4	16.8	11.7	0.70	1.30	21.2	12.9	1.6
	5.0	2.9	6.8	23.3	1.61	17.8	103.9	4.25	2.5	17.0	12.0	0.70	1.26	21.3	13.5	1.5
90	3.0	0.7	1.6	24.7	1.64	19.1	106.2	4.43	2.8	15.4	10.8	0.70	1.49	20.5	10.3	2.2
	4.0	1.5	3.4	25.1	1.66	19.5	106.8	4.44	2.8	15.7	11.1	0.71	1.43	20.5	11.0	2.0
	5.0	2.9	6.6	25.5	1.68	19.8	107.4	4.45	2.8	16.0	11.4	0.71	1.38	20.7	11.6	1.9
100	3.0	0.6	1.4	Operation not recommended						Operation not recommended						
	4.0	1.4	3.2	Operation not recommended						14.9	11.0	0.74	1.52	20.1	9.8	2.5
	5.0	2.8	6.4	Operation not recommended						15.1	11.1	0.73	1.47	20.1	10.3	2.3
110	3.0	0.5	1.2	Operation not recommended						Operation not recommended						
	4.0	1.3	3.0	Operation not recommended						13.9	10.5	0.76	1.60	19.4	8.7	3.2
	5.0	2.7	6.2	Operation not recommended						14.2	10.7	0.75	1.56	19.5	9.1	3.0
120	3.0	0.5	1.1	Operation not recommended						Operation not recommended						
	4.0	1.2	2.9	Operation not recommended						13.2	10.1	0.76	1.76	19.2	7.5	4.0
	5.0	2.6	6.1	Operation not recommended						13.5	10.2	0.76	1.71	19.3	7.9	3.6

YG023 - Performance Data

Single Speed PSC (700 cfm)

EWT °F	Flow gpm	WPD		HEATING - EAT 70°F					COOLING - EAT 80/67°F					
		psi	ft. hd.	HC MBtu/h	Power kW	HE MBtu/h	LAT °F	COP	TC MBtu/h	SC MBtu/h	S/T Ratio	Power kW	HR MBtu/h	EER
20	3.0	1.2	2.8	Operation not recommended					Operation not recommended					
	4.5	2.4	5.6	Operation not recommended					Operation not recommended					
	6.0	4.6	10.6	15.0	1.68	9.2	85.3	2.61	Operation not recommended					
30	3.0	1.1	2.6	Operation not recommended					Operation not recommended					
	4.5	2.4	5.5	17.9	1.74	11.9	88.7	3.01	26.3	16.7	0.63	1.11	30.1	23.8
	6.0	4.5	10.5	18.2	1.76	12.2	89.1	3.04	26.7	17.0	0.64	1.04	30.2	25.7
40	3.0	1.1	2.5	Operation not recommended					Operation not recommended					
	4.5	2.3	5.3	19.6	1.78	13.6	90.7	3.24	26.5	17.0	0.64	1.20	30.6	22.0
	6.0	4.5	10.3	20.3	1.80	14.1	91.4	3.30	26.8	17.3	0.64	1.14	30.7	23.6
50	3.0	1.0	2.3	20.8	1.79	14.7	92.1	3.41	26.4	17.3	0.66	1.37	31.1	19.3
	4.5	2.2	5.2	21.6	1.82	15.4	92.9	3.48	26.6	17.4	0.65	1.30	31.1	20.5
	6.0	4.4	10.2	22.3	1.84	16.0	93.8	3.55	26.9	17.5	0.65	1.23	31.1	21.9
60	3.0	1.0	2.2	23.0	1.83	16.7	94.6	3.68	25.7	17.0	0.66	1.52	30.9	16.9
	4.5	2.2	5.0	23.8	1.85	17.5	95.5	3.76	25.9	17.1	0.66	1.44	30.9	18.0
	6.0	4.3	10.0	24.6	1.88	18.2	96.4	3.84	26.2	17.2	0.66	1.36	30.8	19.3
70	3.0	0.9	2.0	25.2	1.87	18.8	97.1	3.94	25.0	16.7	0.67	1.67	30.7	15.0
	4.5	2.1	4.9	26.0	1.89	19.6	98.1	4.03	25.3	16.8	0.67	1.58	30.6	16.0
	6.0	4.3	9.9	26.9	1.91	20.4	99.1	4.12	25.5	16.9	0.66	1.49	30.6	17.1
80	3.0	0.8	1.9	27.9	1.88	21.5	100.2	4.35	23.8	16.1	0.68	1.81	30.0	13.1
	4.5	2.1	4.7	28.5	1.90	22.0	101.0	4.40	24.1	16.3	0.68	1.73	30.0	13.9
	6.0	4.2	9.7	29.2	1.92	22.6	101.8	4.46	24.5	16.5	0.67	1.68	30.2	14.6
90	3.0	0.8	1.7	30.6	1.88	24.1	103.4	4.76	22.7	15.6	0.69	2.01	29.6	11.3
	4.5	2.0	4.6	31.0	1.91	24.5	103.9	4.77	23.0	15.8	0.69	1.92	29.6	12.0
	6.0	4.1	9.6	31.5	1.93	24.9	104.5	4.78	23.5	16.0	0.68	1.86	29.8	12.6
100	3.0	0.7	1.6	Operation not recommended					Operation not recommended					
	4.5	1.9	4.4	Operation not recommended					21.7	15.1	0.69	2.20	29.2	9.9
	6.0	4.1	9.4	Operation not recommended					22.1	15.2	0.69	2.13	29.3	10.4
110	3.0	0.6	1.4	Operation not recommended					Operation not recommended					
	4.5	1.9	4.3	Operation not recommended					20.2	14.2	0.70	2.46	28.6	8.2
	6.0	4.0	9.3	Operation not recommended					20.6	14.4	0.70	2.39	28.8	8.6
120	3.0	0.6	1.3	Operation not recommended					Operation not recommended					
	4.5	1.8	4.1	Operation not recommended					18.4	14.2	0.77	2.85	28.2	6.5
	6.0	3.9	9.1	Operation not recommended					18.8	14.4	0.77	2.77	28.3	6.8

11/10/09

YG024 - Performance Data

Single Speed PSC (800 cfm)

EWT °F	Flow gpm	WPD		HEATING - EAT 70°F						COOLING - EAT 80/67°F						
		psi	ft. hd.	HC MBtu/h	Power kW	HE MBtu/h	LAT °F	COP	HWC MBtu/h	TC MBtu/h	SC MBtu/h	S/T Ratio	Power kW	HR MBtu/h	EER	HWC MBtu/h
20	3.0	1.2	2.8	Operation not recommended						Operation not recommended						
	4.5	2.4	5.6	Operation not recommended						Operation not recommended						
	6.0	4.6	10.6	15.6	1.68	9.8	86.0	2.72	1.6							
30	3.0	1.1	2.6	Operation not recommended						Operation not recommended						
	4.5	2.4	5.5	18.7	1.74	12.7	89.6	3.14	1.7	27.5	17.4	0.63	1.11	31.2	24.8	---
	6.0	4.5	10.5	19.0	1.76	13.0	90.0	3.16	1.7	27.8	17.7	0.64	1.04	31.4	26.8	---
40	3.0	1.1	2.5	Operation not recommended						Operation not recommended						
	4.5	2.3	5.3	20.5	1.78	14.4	91.7	3.38	1.9	27.6	17.7	0.64	1.20	31.7	22.9	---
	6.0	4.5	10.3	21.1	1.80	15.0	92.4	3.44	1.9	27.9	18.0	0.64	1.14	31.8	24.6	---
50	3.0	1.0	2.3	21.7	1.79	15.6	93.2	3.56	2.1	27.5	18.0	0.65	1.37	32.2	20.1	1.3
	4.5	2.2	5.2	22.5	1.82	16.3	94.0	3.63	2.1	27.8	18.1	0.65	1.30	32.2	21.4	1.2
	6.0	4.4	10.2	23.2	1.84	16.9	94.9	3.70	2.2	28.0	18.2	0.65	1.23	32.2	22.7	1.2
60	3.0	1.0	2.2	24.0	1.83	17.7	95.7	3.84	2.3	26.8	17.7	0.66	1.52	32.0	17.6	1.5
	4.5	2.2	5.0	24.8	1.85	18.5	96.7	3.92	2.4	27.0	17.8	0.66	1.44	32.0	18.8	1.4
	6.0	4.3	10.0	25.6	1.88	19.2	97.6	4.00	2.4	27.3	17.9	0.66	1.36	31.9	20.1	1.4
70	3.0	0.9	2.0	26.2	1.87	19.8	98.3	4.10	2.6	26.1	17.4	0.67	1.67	31.8	15.6	1.8
	4.5	2.1	4.9	27.1	1.89	20.6	99.4	4.20	2.6	26.3	17.5	0.66	1.58	31.7	16.7	1.8
	6.0	4.3	9.9	28.0	1.91	21.5	100.4	4.30	2.7	26.6	17.6	0.66	1.49	31.6	17.8	1.7
80	3.0	0.8	1.9	29.0	1.88	22.6	101.5	4.53	2.9	24.9	16.8	0.68	1.81	31.1	13.7	2.3
	4.5	2.1	4.7	29.7	1.90	23.2	102.4	4.58	2.9	25.2	17.0	0.68	1.73	31.1	14.5	2.2
	6.0	4.2	9.7	30.4	1.92	23.8	103.2	4.64	3.0	25.5	17.1	0.67	1.68	31.2	15.2	2.1
90	3.0	0.8	1.7	31.8	1.88	25.4	104.8	4.95	3.3	23.6	16.2	0.69	2.01	30.5	11.7	2.8
	4.5	2.0	4.6	32.3	1.91	25.8	105.4	4.96	3.4	24.0	16.5	0.69	1.92	30.6	12.5	2.7
	6.0	4.1	9.6	32.8	1.93	26.2	105.9	4.98	3.5	24.5	16.7	0.68	1.86	30.8	13.2	2.5
100	3.0	0.7	1.6	Operation not recommended						Operation not recommended						
	4.5	1.9	4.4	Operation not recommended						22.7	16.0	0.71	2.20	30.2	10.3	3.4
	6.0	4.1	9.4	Operation not recommended						23.0	16.2	0.70	2.13	30.3	10.8	3.2
110	3.0	0.6	1.4	Operation not recommended						Operation not recommended						
	4.5	1.9	4.3	Operation not recommended						21.1	15.4	0.73	2.46	29.5	8.6	4.1
	6.0	4.0	9.3	Operation not recommended						21.5	15.6	0.73	2.39	29.7	9.0	3.9
120	3.0	0.6	1.3	Operation not recommended						Operation not recommended						
	4.5	1.8	4.1	Operation not recommended						19.1	14.8	0.77	2.85	28.9	6.7	4.9
	6.0	3.9	9.1	Operation not recommended						19.6	15.0	0.77	2.77	29.0	7.1	4.6

YG030 - Performance Data

Single Speed PSC (1000 cfm)

EWT °F	Flow gpm	WPD		HEATING - EAT 70°F						COOLING - EAT 80/67°F						
		PSI	FT	HC MBtu/h	Power kW	HE MBtu/h	LAT °F	COP	HWC MBtu/h	TC MBtu/h	SC MBtu/h	S/T Ratio	Power kW	HR MBtu/h	EER	HWC MBtu/h
20	4.0	1.0	2.2	Operation not recommended						Operation not recommended						
	6.0	1.9	4.5	Operation not recommended						Operation not recommended						
	8.0	3.8	8.7	20.0	1.90	13.5	86.5	3.09	1.9							
30	4.0	0.9	2.1	Operation not recommended						Operation not recommended						
	6.0	1.9	4.4	21.2	1.96	14.5	87.6	3.16	2.1	30.4	19.3	0.64	1.38	35.1	21.9	---
	8.0	3.7	8.5	22.0	1.98	15.2	88.4	3.26	2.1	30.8	19.7	0.64	1.30	35.2	23.7	---
40	4.0	0.9	2.0	Operation not recommended						Operation not recommended						
	6.0	1.8	4.3	23.9	2.00	17.1	90.1	3.50	2.3	31.3	20.2	0.64	1.41	36.1	22.1	---
	8.0	3.7	8.4	25.0	2.02	18.1	91.1	3.62	2.4	32.4	20.9	0.65	1.40	37.2	23.1	---
50	4.0	0.8	1.9	25.8	2.01	18.9	91.9	3.76	2.5	30.5	19.9	0.65	1.39	35.2	21.9	1.4
	6.0	1.8	4.1	26.9	2.04	19.9	92.9	3.87	2.6	32.3	21.0	0.65	1.45	37.2	22.3	1.3
	8.0	3.6	8.3	27.9	2.06	20.9	93.8	3.97	2.7	34.0	22.1	0.65	1.50	39.1	22.7	1.3
60	4.0	0.8	1.8	29.4	2.05	22.4	95.2	4.20	2.9	30.1	19.7	0.66	1.54	35.3	19.5	1.6
	6.0	1.7	4.0	30.5	2.07	23.4	96.2	4.31	2.9	31.9	20.9	0.66	1.60	37.4	20.0	1.5
	8.0	3.6	8.2	31.6	2.10	24.5	97.3	4.42	3.0	33.8	22.1	0.66	1.65	39.4	20.5	1.4
70	4.0	0.7	1.6	33.0	2.09	25.9	98.6	4.63	3.2	29.6	19.5	0.66	1.69	35.4	17.5	2.0
	6.0	1.7	3.9	34.2	2.11	27.0	99.6	4.74	3.3	31.6	20.8	0.66	1.75	37.6	18.1	1.9
	8.0	3.5	8.1	35.3	2.13	28.0	100.7	4.86	3.4	33.6	22.2	0.66	1.80	39.7	18.7	1.8
80	4.0	0.7	1.5	36.9	2.19	29.4	102.1	4.93	3.6	29.3	19.3	0.66	2.16	36.6	13.6	2.5
	6.0	1.6	3.8	37.8	2.22	30.2	103.0	4.99	3.7	30.7	20.4	0.66	2.06	37.8	15.0	2.4
	8.0	3.5	8.0	38.7	2.24	31.0	103.8	5.06	3.8	32.1	21.5	0.67	1.99	38.8	16.1	2.3
90	4.0	0.6	1.4	40.7	2.29	32.9	105.7	5.21	4.1	29.0	19.0	0.66	2.36	37.0	12.3	3.3
	6.0	1.6	3.7	41.4	2.32	33.4	106.3	5.22	4.2	29.9	20.0	0.67	2.25	37.6	13.3	3.1
	8.0	3.4	7.9	42.0	2.35	34.0	106.9	5.24	4.3	30.5	20.7	0.68	2.18	37.9	14.0	3.0
100	4.0	0.6	1.3	Operation not recommended						Operation not recommended						
	6.0	1.6	3.6	Operation not recommended						27.5	19.7	0.72	2.58	36.3	10.7	3.9
	8.0	3.4	7.8	Operation not recommended						28.0	19.9	0.71	2.50	36.5	11.2	3.7
110	4.0	0.5	1.2	Operation not recommended						Operation not recommended						
	6.0	1.5	3.5	Operation not recommended						24.9	18.7	0.75	2.89	34.7	8.6	4.9
	8.0	3.3	7.6	Operation not recommended						25.4	19.0	0.75	2.81	35.0	9.0	4.5
120	4.0	0.5	1.1	Operation not recommended						Operation not recommended						
	6.0	1.5	3.3	Operation not recommended						21.1	17.2	0.82	3.09	31.7	6.8	5.7
	8.0	3.3	7.5	Operation not recommended						21.6	17.5	0.81	3.00	31.8	7.2	5.4

11/10/09

YG036 - Performance Data

Single Speed PSC (1250 cfm)

EWT °F	Flow gpm	WPD		HEATING - EAT 70°F						COOLING - EAT 80/67°F						
		psi	ft. hd.	HC MBtu/h	Power kW	HE MBtu/h	LAT °F	COP	HWC MBtu/h	TC MBtu/h	SC MBtu/h	S/T Ratio	Power kW	HR MBtu/h	EER	HWC MBtu/h
20	5.0	1.5	3.4	Operation not recommended						Operation not recommended						
	7.0	2.6	6.0	Operation not recommended						Operation not recommended						
	9.0	6.1	14.1	23.4	2.43	15.1	86.9	2.83	2.3							
30	5.0	1.4	3.1	Operation not recommended						Operation not recommended						
	7.0	2.5	5.8	27.4	2.46	19.0	90.1	3.27	2.5	35.9	25.1	0.70	1.64	41.5	21.9	---
	9.0	6.0	13.8	28.2	2.51	19.6	90.7	3.29	2.6	36.4	25.6	0.70	1.54	41.7	23.6	---
40	5.0	1.3	2.9	Operation not recommended						Operation not recommended						
	7.0	2.4	5.5	30.8	2.52	22.2	92.8	3.58	2.9	38.7	27.2	0.70	1.74	44.6	22.2	---
	9.0	5.9	13.6	31.9	2.57	23.2	93.7	3.65	2.9	39.2	27.5	0.70	1.66	44.9	23.6	---
50	5.0	1.1	2.6	33.3	2.53	24.6	94.8	3.85	3.1	40.9	29.1	0.71	1.90	47.4	21.5	1.6
	7.0	2.3	5.2	34.5	2.58	25.7	95.8	3.92	3.2	41.5	29.2	0.70	1.84	47.7	22.5	1.5
	9.0	5.8	13.3	35.7	2.62	26.8	96.7	3.99	3.3	42.0	29.4	0.70	1.78	48.1	23.6	1.5
60	5.0	1.0	2.4	37.7	2.60	28.8	98.3	4.25	3.5	39.2	28.5	0.73	2.09	46.4	18.8	2.0
	7.0	2.2	5.0	39.0	2.64	30.0	99.4	4.33	3.6	39.9	28.7	0.72	2.02	46.8	19.7	1.9
	9.0	5.7	13.1	40.2	2.67	31.1	100.4	4.42	3.6	40.5	28.9	0.71	1.96	47.2	20.7	1.8
70	5.0	0.9	2.1	42.1	2.67	33.0	101.9	4.62	3.9	37.6	27.9	0.74	2.28	45.3	16.5	2.5
	7.0	2.1	4.7	43.5	2.70	34.3	103.0	4.73	4.0	38.3	28.2	0.74	2.21	45.8	17.4	2.4
	9.0	5.5	12.8	44.8	2.72	35.5	104.1	4.83	4.1	39.0	28.5	0.73	2.13	46.3	18.3	2.3
80	5.0	0.8	1.8	46.7	2.73	37.4	105.6	5.01	4.4	36.1	27.1	0.75	2.55	44.8	14.1	3.2
	7.0	1.9	4.5	47.7	2.76	38.3	106.4	5.07	4.5	36.7	27.6	0.75	2.43	45.0	15.1	3.0
	9.0	5.4	12.5	48.8	2.79	39.3	107.3	5.13	4.6	37.4	28.0	0.75	2.36	45.4	15.9	2.9
90	5.0	0.7	1.6	51.2	2.79	41.7	109.3	5.39	4.9	34.5	26.3	0.76	2.79	44.1	12.4	3.9
	7.0	1.8	4.2	52.0	2.83	42.4	109.9	5.40	5.1	35.1	27.0	0.77	2.67	44.2	13.2	3.7
	9.0	5.3	12.3	52.8	2.86	43.1	110.5	5.41	5.2	35.8	27.5	0.77	2.58	44.6	13.9	3.6
100	5.0	0.6	1.3	Operation not recommended						Operation not recommended						
	7.0	1.7	4.0	Operation not recommended						33.3	26.4	0.79	2.98	43.5	11.2	4.6
	9.0	5.2	12.0	Operation not recommended						33.8	26.6	0.79	2.89	43.6	11.7	4.4
110	5.0	0.5	1.1	Operation not recommended						Operation not recommended						
	7.0	1.6	3.7	Operation not recommended						31.2	25.3	0.81	3.28	42.4	9.5	5.7
	9.0	5.1	11.8	Operation not recommended						31.8	25.7	0.81	3.19	42.7	10.0	5.4
120	5.0	0.4	0.8	Operation not recommended						Operation not recommended						
	7.0	1.5	3.5	Operation not recommended						26.5	22.7	0.85	3.61	38.8	7.4	6.8
	9.0	5.0	11.5	Operation not recommended						27.1	23.0	0.85	3.50	39.0	7.7	6.4

YG041 - Performance Data

Single Speed PSC (1300 cfm)

EWT °F	Flow gpm	WPD		HEATING - EAT 70°F						COOLING - EAT 80/67°F						
		psi	ft. hd	HC MBtu/h	Power kW	HE MBtu/h	LAT °F	COP	HWC MBtu/h	TC MBtu/h	SC MBtu/h	S/T Ratio	Power kW	HR MBtu/h	EER	HWC MBtu/h
20	5.0	1.6	3.8	Operation not recommended						Operation not recommended						
	8.0	3.6	8.2	Operation not recommended						Operation not recommended						
	11.0	8.0	18.5	25.7	2.81	16.1	85.0	2.68	3.5							
30	5.0	1.5	3.4	Operation not recommended						Operation not recommended						
	8.0	3.4	7.8	28.5	2.82	18.9	86.9	2.97	3.7	41.9	30.4	0.73	1.93	48.4	21.7	---
	11.0	7.9	18.1	29.5	2.86	19.7	87.5	3.02	3.8	42.4	31.0	0.73	1.81	48.6	23.4	---
40	5.0	1.3	3.0	Operation not recommended						Operation not recommended						
	8.0	3.2	7.5	31.7	2.88	21.9	89.0	3.23	4.0	43.8	31.4	0.72	2.06	50.9	21.2	---
	11.0	7.7	17.8	33.0	2.91	23.1	89.8	3.33	4.1	44.4	31.9	0.72	1.95	51.1	22.8	---
50	5.0	1.2	2.7	33.7	2.92	23.7	90.3	3.38	4.4	45.2	32.0	0.71	2.31	53.1	19.6	2.4
	8.0	3.1	7.1	35.2	2.94	25.1	91.2	3.50	4.5	45.8	32.4	0.71	2.20	53.3	20.8	2.4
	11.0	7.5	17.4	36.6	2.96	26.5	92.2	3.62	4.7	46.5	32.7	0.70	2.09	53.6	22.2	2.3
60	5.0	1.0	2.3	37.8	2.99	27.7	93.0	3.72	5.0	44.2	31.5	0.71	2.57	52.9	17.2	3.0
	8.0	2.9	6.7	39.3	3.01	29.0	94.0	3.83	5.1	45.1	31.8	0.70	2.43	53.4	18.6	2.8
	11.0	7.4	17.0	40.7	3.03	30.4	94.9	3.95	5.3	46.1	32.1	0.70	2.30	53.9	20.1	2.7
70	5.0	0.9	2.0	42.0	3.05	31.6	95.8	4.03	5.6	43.1	30.9	0.72	2.82	52.7	15.3	3.8
	8.0	2.8	6.4	43.4	3.07	32.9	96.7	4.14	5.7	44.4	31.2	0.70	2.66	53.5	16.7	3.6
	11.0	7.2	16.7	44.8	3.09	34.3	97.7	4.25	5.9	45.7	31.5	0.69	2.50	54.2	18.3	3.4
80	5.0	0.7	1.6	46.9	3.11	36.3	99.0	4.42	6.3	41.7	30.4	0.73	3.02	52.0	13.8	4.8
	8.0	2.6	6.0	48.0	3.15	37.3	99.8	4.48	6.5	42.6	30.6	0.72	2.88	52.5	14.8	4.5
	11.0	7.1	16.3	49.2	3.18	38.3	100.5	4.54	6.7	43.7	30.8	0.71	2.79	53.2	15.7	4.3
90	5.0	0.5	1.2	51.9	3.18	41.0	102.3	4.78	7.1	40.2	29.8	0.74	3.34	51.6	12.1	6.0
	8.0	2.5	5.7	52.7	3.22	41.7	102.8	4.79	7.3	40.9	30.0	0.73	3.18	51.7	12.8	5.7
	11.0	6.9	16.0	53.5	3.26	42.4	103.4	4.81	7.5	41.7	30.1	0.72	3.08	52.2	13.5	5.5
100	5.0	0.4	0.9	Operation not recommended						Operation not recommended						
	8.0	2.3	5.3	Operation not recommended						38.2	29.0	0.76	3.55	50.3	10.8	7.1
	11.0	6.8	15.6	Operation not recommended						38.8	29.2	0.75	3.44	50.5	11.3	6.8
110	5.0	0.4	0.9	Operation not recommended						Operation not recommended						
	8.0	2.1	4.9	Operation not recommended						35.2	27.9	0.79	3.91	48.5	9.0	8.6
	11.0	6.6	15.2	Operation not recommended						35.9	28.3	0.79	3.80	48.9	9.4	8.3
120	5.0	0.4	0.9	Operation not recommended						Operation not recommended						
	8.0	2.0	4.6	Operation not recommended						31.8	27.1	0.85	4.55	47.4	7.0	10.4
	11.0	6.5	14.9	Operation not recommended						32.5	27.5	0.84	4.42	47.6	7.4	10.0

11/10/09

YG042 - Performance Data

Single Speed PSC (1400 cfm)

EWT °F	Flow gpm	WPD		HEATING - EAT 70°F						COOLING - EAT 80/67°F						
		psi	ft. hd.	HC MBtu/h	Power kW	HE MBtu/h	LAT °F	COP	HWC MBtu/h	TC MBtu/h	SC MBtu/h	S/T Ratio	Power kW	HR MBtu/h	EER	HWC MBtu/h
20	5.0	1.6	3.8	Operation not recommended						Operation not recommended						
	8.0	3.6	8.2	Operation not recommended						Operation not recommended						
	11.0	8.0	18.5	27.0	2.81	17.4	85.9	2.82	3.5							
30	5.0	1.5	3.4	Operation not recommended						Operation not recommended						
	8.0	3.4	7.8	30.0	2.82	20.4	87.8	3.12	3.7	43.6	31.7	0.73	1.93	50.2	22.6	---
	11.0	7.9	18.1	31.0	2.86	21.2	88.5	3.18	3.8	44.2	32.3	0.73	1.81	50.4	24.4	---
40	5.0	1.3	3.0	Operation not recommended						Operation not recommended						
	8.0	3.2	7.5	33.4	2.88	23.5	90.1	3.40	4.0	45.7	32.7	0.72	2.06	52.7	22.1	---
	11.0	7.7	17.8	34.8	2.91	24.8	91.0	3.50	4.1	46.3	33.2	0.72	1.95	53.0	23.7	---
50	5.0	1.2	2.7	35.5	2.92	25.5	91.5	3.56	4.4	47.1	33.4	0.71	2.31	55.0	20.4	2.4
	8.0	3.1	7.1	37.0	2.94	27.0	92.5	3.69	4.5	47.8	33.8	0.71	2.20	55.3	21.7	2.4
	11.0	7.5	17.4	38.5	2.96	28.4	93.5	3.81	4.7	48.4	34.1	0.70	2.09	55.5	23.2	2.3
60	5.0	1.0	2.3	39.9	2.99	29.7	94.4	3.91	5.0	46.0	32.8	0.71	2.57	54.8	17.9	3.0
	8.0	2.9	6.7	41.4	3.01	31.1	95.3	4.03	5.1	47.0	33.1	0.70	2.43	55.3	19.3	2.8
	11.0	7.4	17.0	42.9	3.03	32.5	96.3	4.15	5.3	48.0	33.5	0.70	2.30	55.8	20.9	2.7
70	5.0	0.9	2.0	44.2	3.05	33.8	97.2	4.25	5.6	44.9	32.2	0.72	2.82	54.5	15.9	3.8
	8.0	2.8	6.4	45.7	3.07	35.2	98.2	4.36	5.7	46.3	32.5	0.70	2.66	55.3	17.4	3.6
	11.0	7.2	16.7	47.2	3.09	36.7	99.2	4.48	5.9	47.6	32.8	0.69	2.50	56.1	19.0	3.4
80	5.0	0.7	1.6	49.4	3.11	38.8	100.7	4.65	6.3	43.4	31.6	0.73	3.02	53.8	14.4	4.8
	8.0	2.6	6.0	50.6	3.15	39.8	101.5	4.71	6.5	44.4	31.9	0.72	2.88	54.3	15.4	4.5
	11.0	7.1	16.3	51.8	3.18	40.9	102.2	4.78	6.7	45.6	32.1	0.70	2.79	55.1	16.3	4.3
90	5.0	0.5	1.2	54.6	3.18	43.8	104.1	5.04	7.1	42.0	31.0	0.74	3.34	53.4	12.6	6.0
	8.0	2.5	5.7	55.5	3.22	44.5	104.7	5.05	7.3	42.6	31.2	0.73	3.18	53.5	13.4	5.7
	11.0	6.9	16.0	56.3	3.26	45.2	105.2	5.06	7.5	43.5	31.4	0.72	3.08	54.0	14.1	5.5
100	5.0	0.4	0.9	Operation not recommended						Operation not recommended						
	8.0	2.3	5.3	Operation not recommended						39.8	30.2	0.76	3.55	52.0	11.2	7.1
	11.0	6.8	15.6	Operation not recommended						40.5	30.5	0.75	3.44	52.2	11.8	6.8
110	5.0	0.4	0.9	Operation not recommended						Operation not recommended						
	8.0	2.1	4.9	Operation not recommended						36.7	29.1	0.79	3.91	50.0	9.4	8.6
	11.0	6.6	15.2	Operation not recommended						37.4	29.5	0.79	3.80	50.4	9.8	8.3
120	5.0	0.4	0.9	Operation not recommended						Operation not recommended						
	8.0	2.0	4.6	Operation not recommended						33.2	28.2	0.85	4.55	48.7	7.3	10.4
	11.0	6.5	14.9	Operation not recommended						33.9	28.6	0.84	4.42	49.0	7.7	10.0

YG048 - Performance Data

Single Speed PSC (1600 cfm)

EWT °F	Flow gpm	WPD		HEATING - EAT 70°F						COOLING - EAT 80/67°F						
		psi	ft. hd.	HC MBtu/h	Power kW	HE MBtu/h	LAT °F	COP	HWC MBtu/h	TC MBtu/h	SC MBtu/h	S/T Ratio	Power kW	HR MBtu/h	EER	HWC MBtu/h
20	6.0	2.2	5.1	Operation not recommended						Operation not recommended						
	9.0	4.4	10.0	Operation not recommended						Operation not recommended						
	12.0	6.8	15.8	30.8	3.32	19.5	87.0	2.72	4.6	Operation not recommended						
30	6.0	2.0	4.7	Operation not recommended						Operation not recommended						
	9.0	4.2	9.6	35.3	3.31	24.0	89.8	3.12	4.9	50.3	31.3	0.62	2.33	58.3	21.6	---
	12.0	6.7	15.5	35.8	3.35	24.4	90.1	3.13	5.0	51.0	31.9	0.63	2.19	58.5	23.3	---
40	6.0	1.9	4.3	Operation not recommended						Operation not recommended						
	9.0	4.0	9.2	40.1	3.44	28.4	92.8	3.41	5.4	53.1	34.8	0.65	2.52	61.7	21.1	---
	12.0	6.5	15.0	41.9	3.51	30.0	93.9	3.51	5.5	54.0	35.5	0.66	2.39	62.2	22.6	---
50	6.0	1.7	3.9	42.9	3.50	31.0	94.5	3.60	5.9	54.9	37.4	0.68	2.84	64.6	19.3	2.9
	9.0	3.8	8.8	45.5	3.58	33.3	96.1	3.73	6.1	56.0	38.3	0.68	2.72	65.2	20.6	2.8
	12.0	6.3	14.6	48.1	3.66	35.6	97.7	3.85	6.2	57.0	39.1	0.69	2.59	65.8	22.0	2.7
60	6.0	1.5	3.5	49.5	3.67	37.0	98.6	3.96	6.7	54.5	37.4	0.69	3.14	65.2	17.4	3.5
	9.0	3.6	8.4	52.2	3.73	39.5	100.2	4.11	6.8	55.4	38.0	0.69	2.99	65.6	18.5	3.4
	12.0	6.1	14.1	54.9	3.79	42.0	101.9	4.25	7.0	56.2	38.6	0.69	2.85	65.9	19.8	3.2
70	6.0	1.3	3.0	56.1	3.83	43.0	102.6	4.29	7.5	54.1	37.3	0.69	3.43	65.8	15.8	4.5
	9.0	3.5	8.0	58.9	3.87	45.7	104.4	4.46	7.7	54.8	37.7	0.69	3.27	65.9	16.8	4.3
	12.0	5.9	13.7	61.7	3.91	48.4	106.1	4.63	7.9	55.4	38.2	0.69	3.10	66.0	17.9	4.0
80	6.0	1.1	2.6	61.3	3.91	47.9	105.8	4.59	8.4	51.4	35.8	0.70	3.71	64.0	13.9	5.6
	9.0	3.3	7.6	63.2	3.96	49.7	107.0	4.68	8.6	52.1	36.4	0.70	3.54	64.2	14.7	5.3
	12.0	5.8	13.3	65.2	4.01	51.5	108.2	4.77	8.9	52.9	36.9	0.70	3.43	64.6	15.5	5.1
90	6.0	1.0	2.2	66.5	4.00	52.9	109.1	4.88	9.4	48.7	34.3	0.70	4.06	62.5	12.0	7.0
	9.0	3.1	7.1	67.5	4.05	53.7	109.7	4.89	9.7	49.4	35.0	0.71	3.87	62.7	12.8	6.7
	12.0	5.6	12.9	68.6	4.10	54.6	110.3	4.90	10.1	50.4	35.6	0.70	3.75	63.2	13.5	6.4
100	6.0	0.8	1.8	Operation not recommended						Operation not recommended						
	9.0	2.9	6.7	Operation not recommended						46.7	34.3	0.74	4.37	61.6	10.7	8.4
	12.0	5.4	12.5	Operation not recommended						47.4	34.6	0.73	4.23	61.8	11.2	8.0
110	6.0	0.6	1.4	Operation not recommended						Operation not recommended						
	9.0	2.7	6.3	Operation not recommended						43.4	33.2	0.76	4.83	59.9	9.0	10.3
	12.0	5.2	12.1	Operation not recommended						44.3	33.7	0.76	4.70	60.4	9.4	9.7
120	6.0	0.4	1.0	Operation not recommended						Operation not recommended						
	9.0	2.6	5.9	Operation not recommended						40.1	32.0	0.80	5.40	58.5	7.4	12.4
	12.0	5.0	11.6	Operation not recommended						41.0	32.5	0.79	5.24	58.8	7.8	11.8

YG060 - Performance Data

Single Speed PSC (2000 cfm)

EWT °F	Flow gpm	WPD		HEATING - EAT 70°F						COOLING - EAT 80/67°F						
		psi	ft. hd.	HC MBtu/h	Power kW	HE MBtu/h	LAT °F	COP	HWC MBtu/h	TC MBtu/h	SC MBtu/h	S/T Ratio	Power kW	HR MBtu/h	EER	HWC MBtu/h
20	9.0	3.8	8.7	Operation not recommended						Operation not recommended						
	12.0	6.3	14.5	Operation not recommended						Operation not recommended						
	15.0	9.7	22.5	41.9	4.06	28.0	87.4	3.02	5.5							
30	9.0	3.6	8.4	Operation not recommended						Operation not recommended						
	12.0	6.1	14.1	43.8	3.99	30.2	88.3	3.22	5.9	72.0	49.1	0.68	2.96	82.1	24.3	---
	15.0	9.6	22.2	46.5	4.11	32.5	89.5	3.31	6.1	73.0	50.0	0.68	2.78	82.5	26.3	---
40	9.0	3.5	8.0	Operation not recommended						Operation not recommended						
	12.0	6.0	13.7	49.7	4.12	35.6	91.0	3.53	6.6	70.8	48.8	0.69	3.11	81.4	22.8	---
	15.0	9.4	21.7	52.2	4.22	37.8	92.2	3.63	6.7	71.8	49.5	0.69	2.97	81.9	24.2	---
50	9.0	3.3	7.6	54.6	4.20	40.3	93.3	3.81	7.1	68.5	48.0	0.70	3.34	79.9	20.5	3.9
	12.0	5.8	13.4	56.2	4.26	41.7	94.0	3.87	7.3	69.5	48.5	0.70	3.25	80.6	21.4	3.7
	15.0	9.2	21.3	57.8	4.32	43.1	94.8	3.92	7.5	70.5	48.9	0.69	3.16	81.3	22.3	3.5
60	9.0	3.1	7.3	62.2	4.35	47.3	96.8	4.19	8.0	67.3	47.0	0.70	3.64	79.7	18.5	4.8
	12.0	5.6	13.0	64.3	4.41	49.3	97.8	4.28	8.3	68.2	47.6	0.70	3.54	80.3	19.3	4.6
	15.0	9.1	21.0	66.4	4.46	51.2	98.8	4.36	8.5	69.1	48.3	0.70	3.45	80.9	20.1	4.4
70	9.0	3.0	6.9	69.8	4.50	54.4	100.3	4.54	9.0	66.0	46.0	0.70	3.93	79.4	16.8	6.0
	12.0	5.5	12.6	72.4	4.55	56.9	101.5	4.66	9.3	66.9	46.8	0.70	3.83	79.9	17.5	5.7
	15.0	8.9	20.6	75.0	4.60	59.3	102.7	4.78	9.5	67.7	47.6	0.70	3.73	80.4	18.2	5.4
80	9.0	2.8	6.5	76.2	4.59	60.6	103.3	4.87	10.2	62.2	45.0	0.72	4.45	77.4	14.0	7.6
	12.0	5.3	12.3	78.2	4.65	62.3	104.2	4.93	10.5	63.1	45.7	0.72	4.25	77.6	14.9	7.2
	15.0	8.8	20.2	80.1	4.70	64.1	105.1	5.00	10.7	64.1	46.3	0.72	4.11	78.1	15.6	6.8
90	9.0	2.7	6.1	82.7	4.68	66.8	106.3	5.18	11.4	58.4	43.9	0.75	4.86	75.0	12.0	9.5
	12.0	5.2	11.9	84.0	4.74	67.8	106.9	5.19	11.8	59.3	44.6	0.75	4.64	75.2	12.8	9.0
	15.0	8.6	19.9	85.3	4.80	68.9	107.5	5.21	12.2	60.5	45.0	0.74	4.49	75.9	13.5	8.6
100	9.0	2.5	5.8	Operation not recommended						Operation not recommended						
	12.0	5.0	11.5	Operation not recommended						56.1	43.4	0.77	5.15	73.7	10.9	11.2
	15.0	8.4	19.5	Operation not recommended						57.0	43.7	0.77	4.99	74.0	11.4	10.6
110	9.0	2.3	5.4	Operation not recommended						Operation not recommended						
	12.0	4.8	11.2	Operation not recommended						52.3	41.8	0.80	5.63	71.6	9.3	13.8
	15.0	8.3	19.1	Operation not recommended						53.4	42.4	0.79	5.48	72.1	9.7	13.1
120	9.0	2.2	5.0	Operation not recommended						Operation not recommended						
	12.0	4.7	10.8	Operation not recommended						48.0	39.9	0.83	6.25	69.3	7.7	16.6
	15.0	8.1	18.8	Operation not recommended						49.0	40.5	0.83	6.07	69.7	8.1	15.9

YG070 - Performance Data

Single Speed PSC (2200 cfm)

EWT °F	Flow gpm	WPD		HEATING - EAT 70°F						COOLING - EAT 80/67°F						
		psi	ft. hd.	HC MBtu/h	Power kW	HE MBtu/h	LAT °F	COP	HWC MBtu/h	TC MBtu/h	SC MBtu/h	S/T Ratio	Power kW	HR MBtu/h	EER	HWC MBtu/h
20	12.0	4.3	9.8	Operation not recommended						Operation not recommended						
	15.0	5.6	13.0	Operation not recommended						Operation not recommended						
	18.0	9.0	20.8	46.0	4.98	29.0	87.4	2.71	6.5	Operation not recommended						
30	12.0	4.1	9.4	Operation not recommended						Operation not recommended						
	15.0	5.9	13.6	52.0	4.92	35.2	89.9	3.09	7.0	73.0	46.1	0.63	3.30	84.3	22.1	---
	18.0	8.8	20.3	53.7	5.06	36.4	90.6	3.11	7.3	74.0	47.0	0.64	3.10	84.6	23.9	---
40	12.0	3.8	8.8	Operation not recommended						Operation not recommended						
	15.0	5.2	12.0	58.4	5.10	41.0	92.6	3.35	7.8	74.6	49.3	0.66	3.49	86.5	21.4	---
	18.0	8.6	19.8	60.9	5.20	43.1	93.6	3.43	8.0	76.1	50.5	0.66	3.36	87.5	22.7	---
50	12.0	3.6	8.4	62.8	5.25	44.9	94.4	3.51	8.5	74.2	51.0	0.69	3.74	87.0	19.8	4.3
	15.0	5.0	11.5	65.4	5.29	47.4	95.5	3.62	8.7	76.2	52.5	0.69	3.68	88.7	20.7	4.1
	18.0	8.4	19.3	68.0	5.33	49.8	96.6	3.74	8.9	78.2	54.0	0.69	3.61	90.5	21.7	3.9
60	12.0	3.4	7.9	71.9	5.46	53.3	98.3	3.86	9.5	71.6	50.0	0.70	4.08	85.5	17.6	5.2
	15.0	4.8	11.0	73.9	5.49	55.2	99.1	3.95	9.8	73.3	51.3	0.70	4.00	87.0	18.3	4.9
	18.0	8.2	18.8	76.0	5.52	57.2	100.0	4.03	10.1	75.1	52.5	0.70	3.92	88.4	19.1	4.8
70	12.0	3.2	7.4	81.0	5.66	61.7	102.1	4.19	10.7	69.0	49.0	0.71	4.41	84.0	15.6	6.6
	15.0	4.6	10.5	82.5	5.69	63.1	102.7	4.25	11.0	70.5	50.0	0.71	4.32	85.2	16.3	6.3
	18.0	7.9	18.3	84.0	5.71	64.5	103.3	4.31	11.3	71.9	51.0	0.71	4.23	86.4	17.0	6.0
80	12.0	3.0	6.9	89.7	5.82	69.8	105.8	4.52	12.1	65.3	47.4	0.73	5.04	82.5	12.9	8.3
	15.0	4.4	10.0	91.2	5.88	71.2	106.4	4.55	12.4	66.5	48.3	0.73	4.81	82.9	13.8	7.9
	18.0	7.7	17.9	92.7	5.93	72.5	107.0	4.59	12.8	67.9	49.0	0.72	4.66	83.8	14.6	7.5
90	12.0	2.8	6.4	98.4	5.99	78.0	109.4	4.82	13.6	61.6	45.8	0.74	5.50	80.4	11.2	10.4
	15.0	4.1	9.5	99.9	6.07	79.2	110.1	4.83	14.0	62.5	46.6	0.75	5.25	80.4	11.9	9.9
	18.0	7.5	17.3	101.5	6.14	80.5	110.7	4.84	14.4	63.8	47.0	0.74	5.08	81.1	12.6	9.4
100	12.0	2.5	5.9	Operation not recommended						Operation not recommended						
	15.0	3.9	9.1	Operation not recommended						59.7	44.9	0.75	5.83	79.6	10.2	12.4
	18.0	7.3	16.9	Operation not recommended						60.6	45.3	0.75	5.65	79.8	10.7	11.7
110	12.0	2.3	5.4	Operation not recommended						Operation not recommended						
	15.0	3.7	8.5	Operation not recommended						56.2	42.9	0.76	6.38	78.0	8.8	15.1
	18.0	7.1	16.4	Operation not recommended						57.4	43.5	0.76	6.21	78.5	9.2	14.3
120	12.0	2.1	4.9	Operation not recommended						Operation not recommended						
	15.0	3.5	8.1	Operation not recommended						51.9	41.4	0.80	7.09	76.0	7.3	18.2
	18.0	6.9	15.9	Operation not recommended						53.0	42.0	0.79	6.88	76.4	7.7	17.3

YG015 - Performance Data

Single Speed Variable Speed ECM or 5-Speed ECM (500 cfm)

EWT °F	Flow gpm	WPD		HEATING - EAT 70°F						COOLING - EAT 80/67°F						
		psi	ft. hd.	HC MBtu/h	Power kW	HE MBtu/h	LAT °F	COP	HWC MBtu/h	TC MBtu/h	SC MBtu/h	S/T Ratio	Power kW	HR MBtu/h	EER	HWC MBtu/h
20	2.0	0.6	1.4	Operation not recommended						Operation not recommended						
	3.0	1.2	2.8	Operation not recommended						Operation not recommended						
	4.0	2.0	4.6	10.0	0.95	6.8	86.5	3.09	1.2							
30	2.0	0.6	1.4	Operation not recommended						Operation not recommended						
	3.0	1.1	2.6	11.0	0.99	7.6	88.3	3.25	1.3	14.5	9.8	0.68	0.66	16.8	22.0	---
	4.0	1.9	4.4	11.0	0.95	7.8	88.4	3.39	1.3	14.7	10.0	0.68	0.62	16.8	23.7	---
40	2.0	0.6	1.3	Operation not recommended						Operation not recommended						
	3.0	1.1	2.5	12.1	1.00	8.7	90.4	3.54	1.3	15.6	10.6	0.68	0.72	18.1	21.7	---
	4.0	1.8	4.3	12.4	0.99	9.0	90.9	3.67	1.3	15.9	10.8	0.68	0.69	18.2	23.0	---
50	2.0	0.5	1.2	13.0	1.01	9.6	92.1	3.77	1.4	16.5	11.3	0.68	0.80	19.2	20.6	0.8
	3.0	1.0	2.3	13.4	1.02	9.9	92.7	3.85	1.4	16.8	11.4	0.68	0.78	19.4	21.5	0.8
	4.0	1.8	4.1	13.7	1.02	10.2	93.4	3.94	1.5	17.0	11.5	0.68	0.76	19.6	22.4	0.8
60	2.0	0.5	1.2	14.4	1.02	10.9	94.6	4.12	1.6	15.7	10.9	0.69	0.87	18.7	18.2	0.9
	3.0	0.9	2.1	14.8	1.03	11.3	95.4	4.22	1.6	16.0	11.0	0.69	0.84	18.8	19.1	0.9
	4.0	1.7	3.9	15.3	1.04	11.7	96.2	4.32	1.7	16.2	11.1	0.68	0.81	18.9	20.1	0.8
70	2.0	0.5	1.1	15.7	1.03	12.2	97.1	4.47	1.8	14.9	10.5	0.70	0.93	18.1	16.0	1.1
	3.0	0.8	1.9	16.3	1.04	12.7	98.1	4.58	1.8	15.2	10.6	0.70	0.89	18.2	17.0	1.1
	4.0	1.6	3.7	16.8	1.05	13.2	99.1	4.69	1.8	15.4	10.6	0.69	0.85	18.3	18.1	1.0
80	2.0	0.5	1.1	17.6	1.05	14.0	100.5	4.92	2.0	14.2	10.2	0.72	0.98	17.5	14.4	1.4
	3.0	0.8	1.8	18.0	1.06	14.4	101.3	4.98	2.0	14.4	10.3	0.71	0.94	17.6	15.4	1.3
	4.0	1.5	3.6	18.4	1.07	14.7	102.1	5.04	2.1	14.7	10.4	0.71	0.91	17.7	16.2	1.3
90	2.0	0.4	1.0	19.4	1.06	15.8	103.9	5.35	2.3	13.4	9.9	0.74	1.04	17.0	12.9	1.8
	3.0	0.7	1.6	19.7	1.08	16.0	104.5	5.36	2.3	13.6	10.0	0.73	0.99	17.0	13.7	1.7
	4.0	1.5	3.4	20.0	1.09	16.3	105.0	5.38	2.3	13.9	10.1	0.73	0.96	17.2	14.5	1.6
100	2.0	0.4	0.9	Operation not recommended						Operation not recommended						
	3.0	0.6	1.4	Operation not recommended						12.8	9.7	0.76	1.11	16.5	11.5	2.1
	4.0	1.4	3.2	Operation not recommended						13.0	9.8	0.76	1.08	16.6	12.0	1.9
110	2.0	0.4	0.9	Operation not recommended						Operation not recommended						
	3.0	0.5	1.2	Operation not recommended						11.8	9.4	0.80	1.22	15.9	9.6	2.7
	4.0	1.3	3.0	Operation not recommended						12.0	9.5	0.79	1.19	16.1	10.1	2.5
120	2.0	0.4	0.9	Operation not recommended						Operation not recommended						
	3.0	0.5	1.1	Operation not recommended						10.8	9.1	0.84	1.36	15.4	7.9	3.3
	4.0	1.2	2.9	Operation not recommended						11.0	9.2	0.84	1.32	15.5	8.3	3.0

YG018 - Performance Data

Single Speed Variable Speed ECM or 5-Speed ECM (600 cfm)

EWT °F	Flow gpm	WPD		HEATING - EAT 70°F						COOLING - EAT 80/67°F						
		psi	ft. hd.	HC MBtu/h	Power kW	HE MBtu/h	LAT °F	COP	HWC MBtu/h	TC MBtu/h	SC MBtu/h	S/T Ratio	Power kW	HR MBtu/h	EER	HWC MBtu/h
20	3.0	1.2	2.8	Operation not recommended						Operation not recommended						
	4.0	2.0	4.6	Operation not recommended						Operation not recommended						
	5.0	3.4	7.8	13.0	1.15	9.1	88.1	3.31	1.4	Operation not recommended						
30	3.0	1.1	2.6	Operation not recommended						Operation not recommended						
	4.0	1.9	4.4	14.5	1.23	10.3	90.3	3.45	1.5	18.2	11.8	0.65	0.80	20.9	22.7	---
	5.0	3.3	7.6	14.9	1.25	10.6	91.0	3.49	1.5	18.4	12.0	0.65	0.75	21.0	24.5	---
40	3.0	1.1	2.5	Operation not recommended						Operation not recommended						
	4.0	1.8	4.3	15.7	1.28	11.3	92.2	3.59	1.6	19.1	12.4	0.65	0.85	22.0	22.3	---
	5.0	3.2	7.5	16.5	1.31	12.0	93.4	3.68	1.6	19.4	12.6	0.65	0.83	22.2	23.5	---
50	3.0	1.0	2.3	16.0	1.30	11.6	92.7	3.61	1.7	19.7	12.8	0.65	0.92	22.8	21.4	0.9
	4.0	1.8	4.1	17.0	1.34	12.4	94.2	3.73	1.7	20.0	13.0	0.65	0.91	23.1	22.0	0.9
	5.0	3.2	7.3	18.0	1.37	13.3	95.8	3.85	1.8	20.3	13.1	0.65	0.90	23.4	22.6	0.9
60	3.0	0.9	2.1	17.5	1.37	12.8	95.0	3.76	1.9	18.7	12.4	0.66	1.01	22.1	18.6	1.1
	4.0	1.7	3.9	18.5	1.39	13.7	96.5	3.89	1.9	18.9	12.6	0.67	1.00	22.3	19.0	1.1
	5.0	3.1	7.1	19.5	1.42	14.7	98.1	4.02	2.0	19.2	12.8	0.67	0.99	22.5	19.4	1.0
70	3.0	0.8	1.9	19.0	1.43	14.1	97.3	3.89	2.1	17.7	12.0	0.68	1.09	21.4	16.2	1.3
	4.0	1.6	3.7	20.0	1.45	15.1	98.9	4.04	2.1	17.9	12.3	0.69	1.08	21.5	16.5	1.3
	5.0	3.0	6.9	21.0	1.47	16.0	100.4	4.19	2.2	18.0	12.5	0.69	1.07	21.7	16.8	1.2
80	3.0	0.8	1.8	21.9	1.50	16.7	101.7	4.26	2.4	16.6	11.4	0.69	1.29	21.0	12.8	1.7
	4.0	1.5	3.6	22.6	1.53	17.4	102.8	4.33	2.4	16.8	11.7	0.70	1.23	21.0	13.6	1.6
	5.0	2.9	6.8	23.3	1.55	18.0	103.9	4.41	2.5	17.0	12.0	0.70	1.20	21.1	14.2	1.5
90	3.0	0.7	1.6	24.7	1.58	19.3	106.2	4.59	2.8	15.4	10.8	0.70	1.43	20.3	10.8	2.2
	4.0	1.5	3.4	25.1	1.60	19.7	106.8	4.60	2.8	15.7	11.1	0.71	1.36	20.3	11.5	2.0
	5.0	2.9	6.6	25.5	1.62	20.0	107.4	4.61	2.8	16.0	11.4	0.71	1.32	20.5	12.1	1.9
100	3.0	0.6	1.4	Operation not recommended						Operation not recommended						
	4.0	1.4	3.2	Operation not recommended						14.9	11.0	0.74	1.46	19.8	10.2	2.5
	5.0	2.8	6.4	Operation not recommended						15.1	11.1	0.73	1.41	19.9	10.7	2.3
110	3.0	0.5	1.2	Operation not recommended						Operation not recommended						
	4.0	1.3	3.0	Operation not recommended						13.9	10.5	0.76	1.54	19.2	9.0	3.2
	5.0	2.7	6.2	Operation not recommended						14.2	10.7	0.75	1.50	19.3	9.5	3.0
120	3.0	0.5	1.1	Operation not recommended						Operation not recommended						
	4.0	1.2	2.9	Operation not recommended						13.2	10.1	0.76	1.70	19.0	7.8	4.0
	5.0	2.6	6.1	Operation not recommended						13.5	10.2	0.76	1.65	19.1	8.2	3.6

11/10/09

YG023 - Performance Data

Single Speed Variable Speed ECM or 5-Speed ECM (800 cfm)

EWT °F	Flow gpm	WPD		HEATING - EAT 70°F					COOLING - EAT 80/67°F					
		psi	ft. hd.	HC MBtu/h	Power kW	HE MBtu/h	LAT °F	COP	TC MBtu/h	SC MBtu/h	S/T Ratio	Power kW	HR MBtu/h	EER
20	3.0	1.2	2.8	Operation not recommended					Operation not recommended					
	4.5	2.4	5.6	Operation not recommended					Operation not recommended					
	6.0	4.6	10.6	15.0	1.53	9.8	85.4	2.87	Operation not recommended					
30	3.0	1.1	2.6	Operation not recommended					Operation not recommended					
	4.5	2.4	5.5	17.9	1.59	12.4	88.7	3.29	26.3	16.7	0.63	0.94	29.6	27.9
	6.0	4.5	10.5	18.2	1.61	12.7	89.1	3.31	26.7	17.0	0.64	0.89	29.7	30.2
40	3.0	1.1	2.5	Operation not recommended					Operation not recommended					
	4.5	2.3	5.3	19.6	1.63	14.1	90.7	3.54	26.5	17.0	0.64	1.04	30.1	25.4
	6.0	4.5	10.3	20.3	1.65	14.6	91.4	3.60	26.8	17.3	0.64	0.98	30.1	27.3
50	3.0	1.0	2.3	20.8	1.64	15.2	92.1	3.71	26.4	17.3	0.66	1.22	30.6	21.7
	4.5	2.2	5.2	21.6	1.66	15.9	92.9	3.79	26.7	17.4	0.65	1.15	30.6	23.2
	6.0	4.4	10.2	22.3	1.69	16.5	93.8	3.87	26.9	17.5	0.65	1.08	30.6	25.0
60	3.0	1.0	2.2	23.0	1.68	17.3	94.6	4.01	25.7	17.0	0.66	1.37	30.4	18.8
	4.5	2.2	5.0	23.8	1.70	18.0	95.5	4.09	26.0	17.1	0.66	1.29	30.3	20.2
	6.0	4.3	10.0	24.6	1.72	18.7	96.5	4.18	26.2	17.2	0.66	1.21	30.3	21.7
70	3.0	0.9	2.0	25.2	1.72	19.3	97.2	4.28	25.0	16.7	0.67	1.52	30.2	16.5
	4.5	2.1	4.9	26.1	1.74	20.1	98.2	4.38	25.3	16.8	0.67	1.43	30.1	17.7
	6.0	4.3	9.9	26.9	1.76	20.9	99.1	4.48	25.5	16.9	0.66	1.34	30.1	19.0
80	3.0	0.8	1.9	27.9	1.73	22.0	100.3	4.72	23.8	16.2	0.68	1.65	29.5	14.4
	4.5	2.1	4.7	28.5	1.75	22.6	101.0	4.78	24.1	16.3	0.68	1.58	29.5	15.3
	6.0	4.2	9.7	29.2	1.77	23.2	101.8	4.83	24.5	16.5	0.67	1.53	29.7	16.1
90	3.0	0.8	1.7	30.6	1.74	24.6	103.4	5.16	22.7	15.6	0.69	1.85	29.0	12.2
	4.5	2.0	4.6	31.0	1.76	25.0	103.9	5.17	23.0	15.8	0.69	1.77	29.1	13.0
	6.0	4.1	9.6	31.5	1.78	25.4	104.5	5.19	23.5	16.0	0.68	1.71	29.3	13.7
100	3.0	0.7	1.6	Operation not recommended					Operation not recommended					
	4.5	1.9	4.4	Operation not recommended					21.7	15.1	0.69	2.04	28.7	10.7
	6.0	4.1	9.4	Operation not recommended					22.1	15.2	0.69	1.97	28.8	11.2
110	3.0	0.6	1.4	Operation not recommended					Operation not recommended					
	4.5	1.9	4.3	Operation not recommended					20.2	14.2	0.70	2.30	28.0	8.8
	6.0	4.0	9.3	Operation not recommended					20.6	14.4	0.70	2.24	28.2	9.2
120	3.0	0.6	1.3	Operation not recommended					Operation not recommended					
	4.5	1.8	4.1	Operation not recommended					18.4	14.2	0.77	2.70	27.6	6.8
	6.0	3.9	9.1	Operation not recommended					18.8	14.4	0.77	2.63	27.8	7.2

YG024 - Performance Data

Single Speed Variable Speed ECM or 5-Speed ECM (800 cfm)

EWT °F	Flow gpm	WPD		HEATING - EAT 70°F						COOLING - EAT 80/67°F						
		psi	ft. hd.	HC MBtu/h	Power kW	HE MBtu/h	LAT °F	COP	HWC MBtu/h	TC MBtu/h	SC MBtu/h	S/T Ratio	Power kW	HR MBtu/h	EER	HWC MBtu/h
20	3.0	1.2	2.8	Operation not recommended						Operation not recommended						
	4.5	2.4	5.6	Operation not recommended						Operation not recommended						
	6.0	4.6	10.6	15.6	1.53	10.3	86.0	2.98	1.6							
30	3.0	1.1	2.6	Operation not recommended						Operation not recommended						
	4.5	2.4	5.5	18.7	1.59	13.2	89.6	3.44	1.7	27.5	17.4	0.63	0.94	30.7	29.1	---
	6.0	4.5	10.5	19.0	1.61	13.5	90.0	3.46	1.7	27.8	17.7	0.64	0.89	30.9	31.5	---
40	3.0	1.1	2.5	Operation not recommended						Operation not recommended						
	4.5	2.3	5.3	20.5	1.63	14.9	91.7	3.69	1.9	27.6	17.7	0.64	1.04	31.2	26.4	---
	6.0	4.5	10.3	21.1	1.65	15.5	92.4	3.75	1.9	27.9	18.0	0.64	0.98	31.3	28.5	---
50	3.0	1.0	2.3	21.7	1.64	16.1	93.2	3.88	2.1	27.5	18.0	0.65	1.22	31.7	22.6	1.3
	4.5	2.2	5.2	22.5	1.66	16.8	94.0	3.96	2.1	27.8	18.1	0.65	1.15	31.7	24.2	1.2
	6.0	4.4	10.2	23.2	1.69	17.4	94.9	4.03	2.2	28.0	18.2	0.65	1.08	31.6	26.0	1.2
60	3.0	1.0	2.2	24.0	1.68	18.2	95.7	4.17	2.3	26.8	17.7	0.66	1.37	31.5	19.6	1.5
	4.5	2.2	5.0	24.8	1.70	19.0	96.7	4.26	2.4	27.0	17.8	0.66	1.29	31.4	21.0	1.4
	6.0	4.3	10.0	25.6	1.72	19.7	97.6	4.35	2.4	27.3	17.9	0.66	1.21	31.4	22.6	1.4
70	3.0	0.9	2.0	26.2	1.72	20.3	98.3	4.45	2.6	26.1	17.4	0.67	1.52	31.3	17.2	1.8
	4.5	2.1	4.9	27.1	1.74	21.1	99.4	4.56	2.6	26.3	17.5	0.66	1.43	31.2	18.4	1.8
	6.0	4.3	9.9	28.0	1.76	22.0	100.4	4.66	2.7	26.6	17.6	0.66	1.34	31.1	19.8	1.7
80	3.0	0.8	1.9	29.0	1.73	23.1	101.5	4.91	2.9	24.9	16.8	0.68	1.65	30.5	15.0	2.3
	4.5	2.1	4.7	29.7	1.75	23.7	102.4	4.97	2.9	25.2	17.0	0.68	1.58	30.5	16.0	2.2
	6.0	4.2	9.7	30.4	1.77	24.3	103.2	5.03	3.0	25.5	17.1	0.67	1.53	30.7	16.7	2.1
90	3.0	0.8	1.7	31.8	1.74	25.9	104.8	5.37	3.3	23.6	16.2	0.69	1.85	29.9	12.8	2.8
	4.5	2.0	4.6	32.3	1.76	26.3	105.4	5.38	3.4	24.0	16.5	0.69	1.77	30.0	13.6	2.7
	6.0	4.1	9.6	32.8	1.78	26.7	105.9	5.40	3.5	24.5	16.7	0.68	1.71	30.3	14.3	2.5
100	3.0	0.7	1.6	Operation not recommended						Operation not recommended						
	4.5	1.9	4.4	Operation not recommended						22.7	16.0	0.71	2.04	29.6	11.1	3.4
	6.0	4.1	9.4	Operation not recommended						23.0	16.2	0.70	1.97	29.7	11.7	3.2
110	3.0	0.6	1.4	Operation not recommended						Operation not recommended						
	4.5	1.9	4.3	Operation not recommended						21.1	15.4	0.73	2.30	29.0	9.2	4.1
	6.0	4.0	9.3	Operation not recommended						21.5	15.6	0.73	2.24	29.2	9.6	3.9
120	3.0	0.6	1.3	Operation not recommended						Operation not recommended						
	4.5	1.8	4.1	Operation not recommended						19.1	14.8	0.77	2.70	28.4	7.1	4.9
	6.0	3.9	9.1	Operation not recommended						19.6	15.0	0.77	2.63	28.5	7.4	4.6

11/10/09

YG030 - Performance Data

Single Speed Variable Speed ECM or 5-Speed ECM (1000 cfm)

EWT °F	Flow gpm	WPD		HEATING - EAT 70°F						COOLING - EAT 80/67°F						
		psi	ft. hd.	HC MBtu/h	Power kW	HE MBtu/h	LAT °F	COP	HWC MBtu/h	TC MBtu/h	SC MBtu/h	S/T Ratio	Power kW	HR MBtu/h	EER	HWC MBtu/h
20	4.0	1.0	2.2	Operation not recommended						Operation not recommended						
	6.0	1.9	4.5	Operation not recommended						Operation not recommended						
	8.0	3.8	8.7	20.0	1.70	14.2	86.5	3.45	1.9							
30	4.0	0.9	2.1	Operation not recommended						Operation not recommended						
	6.0	1.9	4.4	21.2	1.76	15.1	87.6	3.52	2.1	30.4	19.3	0.64	1.17	34.4	25.9	---
	8.0	3.7	8.5	22.0	1.78	15.9	88.4	3.62	2.1	30.8	19.7	0.64	1.10	34.6	28.0	---
40	4.0	0.9	2.0	Operation not recommended						Operation not recommended						
	6.0	1.8	4.3	23.9	1.80	17.7	90.1	3.89	2.3	31.3	20.2	0.64	1.21	35.4	25.9	---
	8.0	3.7	8.4	25.0	1.82	18.7	91.1	4.02	2.4	32.4	20.9	0.65	1.20	36.5	27.0	---
50	4.0	0.8	1.9	25.8	1.81	19.6	91.9	4.18	2.5	30.5	19.9	0.65	1.19	34.6	25.6	1.4
	6.0	1.8	4.1	26.9	1.84	20.6	92.9	4.29	2.6	32.3	21.0	0.65	1.25	36.5	25.9	1.3
	8.0	3.6	8.3	27.9	1.86	21.6	93.8	4.40	2.7	34.0	22.1	0.65	1.30	38.4	26.2	1.3
60	4.0	0.8	1.8	29.4	1.85	23.1	95.2	4.66	2.9	30.1	19.7	0.66	1.34	34.6	22.4	1.6
	6.0	1.7	4.0	30.5	1.87	24.1	96.2	4.77	2.9	31.9	20.9	0.66	1.40	36.7	22.9	1.5
	8.0	3.6	8.2	31.6	1.90	25.1	97.3	4.89	3.0	33.8	22.1	0.66	1.45	38.7	23.3	1.4
70	4.0	0.7	1.6	33.0	1.89	26.6	98.6	5.12	3.2	29.6	19.5	0.66	1.49	34.7	19.9	2.0
	6.0	1.7	3.9	34.2	1.91	27.6	99.6	5.24	3.3	31.6	20.8	0.66	1.55	36.9	20.5	1.9
	8.0	3.5	8.1	35.3	1.93	28.7	100.7	5.36	3.4	33.6	22.2	0.66	1.60	39.1	21.0	1.8
80	4.0	0.7	1.5	36.9	1.99	30.1	102.1	5.42	3.6	29.3	19.3	0.66	1.94	35.9	15.1	2.5
	6.0	1.6	3.8	37.8	2.02	30.9	103.0	5.49	3.7	30.7	20.4	0.66	1.85	37.1	16.6	2.4
	8.0	3.5	8.0	38.7	2.04	31.7	103.8	5.55	3.8	32.1	21.5	0.67	1.79	38.2	17.9	2.3
90	4.0	0.6	1.4	40.7	2.10	33.6	105.7	5.70	4.1	29.0	19.0	0.66	2.14	36.3	13.5	3.3
	6.0	1.6	3.7	41.4	2.12	34.1	106.3	5.71	4.2	29.9	20.0	0.67	2.05	36.9	14.6	3.1
	8.0	3.4	7.9	42.0	2.15	34.7	106.9	5.73	4.3	30.5	20.7	0.68	1.98	37.3	15.4	3.0
100	4.0	0.6	1.3	Operation not recommended						Operation not recommended						
	6.0	1.6	3.6	Operation not recommended						27.5	19.7	0.72	2.37	35.6	11.6	3.9
	8.0	3.4	7.8	Operation not recommended						28.0	19.9	0.71	2.30	35.8	12.2	3.7
110	4.0	0.5	1.2	Operation not recommended						Operation not recommended						
	6.0	1.5	3.5	Operation not recommended						24.9	18.7	0.75	2.68	34.0	9.3	4.9
	8.0	3.3	7.6	Operation not recommended						25.4	19.0	0.75	2.61	34.3	9.7	4.5
120	4.0	0.5	1.1	Operation not recommended						Operation not recommended						
	6.0	1.5	3.3	Operation not recommended						21.1	17.2	0.82	2.88	31.0	7.3	5.7
	8.0	3.3	7.5	Operation not recommended						21.6	17.5	0.81	2.80	31.2	7.7	5.4

YG036 - Performance Data

Single Speed Variable Speed ECM or 5-Speed ECM (1150 cfm)

EWT °F	Flow gpm	WPD		HEATING - EAT 70°F						COOLING - EAT 80/67°F						
		psi	ft. hd.	HC MBtu/h	Power kW	HE MBtu/h	LAT °F	COP	HWC MBtu/h	TC MBtu/h	SC MBtu/h	S/T Ratio	Power kW	HR MBtu/h	EER	HWC MBtu/h
20	5.0	1.5	3.4	Operation not recommended						Operation not recommended						
	7.0	2.6	6.0	Operation not recommended						Operation not recommended						
	9.0	6.1	14.1	23.4	2.31	15.6	86.9	2.97	2.3							
30	5.0	1.4	3.1	Operation not recommended						Operation not recommended						
	7.0	2.5	5.8	27.4	2.34	19.4	90.1	3.43	2.5	35.9	25.1	0.70	1.51	41.1	23.7	---
	9.0	6.0	13.8	28.2	2.38	20.1	90.7	3.47	2.6	36.4	25.6	0.70	1.42	41.2	25.6	---
40	5.0	1.3	2.9	Operation not recommended						Operation not recommended						
	7.0	2.4	5.5	30.8	2.40	22.6	92.8	3.76	2.9	38.7	27.2	0.70	1.62	44.2	23.9	---
	9.0	5.9	13.6	31.9	2.44	23.6	93.7	3.84	2.9	39.2	27.5	0.70	1.54	44.5	25.5	---
50	5.0	1.1	2.6	33.3	2.41	25.0	94.8	4.05	3.1	40.9	29.1	0.71	1.78	47.0	23.0	1.6
	7.0	2.3	5.2	34.5	2.46	26.1	95.8	4.12	3.2	41.5	29.2	0.70	1.72	47.3	24.1	1.5
	9.0	5.8	13.3	35.7	2.50	27.2	96.7	4.18	3.3	42.0	29.4	0.70	1.66	47.7	25.3	1.5
60	5.0	1.0	2.4	37.7	2.48	29.2	98.3	4.45	3.5	39.2	28.5	0.73	1.97	46.0	19.9	2.0
	7.0	2.2	5.0	39.0	2.52	30.4	99.4	4.54	3.6	39.9	28.7	0.72	1.90	46.4	21.0	1.9
	9.0	5.7	13.1	40.2	2.55	31.5	100.4	4.62	3.6	40.5	28.9	0.71	1.84	46.8	22.1	1.8
70	5.0	0.9	2.1	42.1	2.55	33.4	101.9	4.84	3.9	37.6	27.9	0.74	2.16	44.9	17.4	2.5
	7.0	2.1	4.7	43.5	2.58	34.7	103.0	4.95	4.0	38.3	28.2	0.74	2.09	45.4	18.4	2.4
	9.0	5.5	12.8	44.8	2.60	35.9	104.1	5.05	4.1	39.0	28.5	0.73	2.01	45.9	19.4	2.3
80	5.0	0.8	1.8	46.7	2.62	37.8	105.6	5.23	4.4	36.1	27.1	0.75	2.42	44.3	14.9	3.2
	7.0	1.9	4.5	47.7	2.65	38.7	106.4	5.29	4.5	36.7	27.6	0.75	2.31	44.6	15.9	3.0
	9.0	5.4	12.5	48.8	2.68	39.7	107.3	5.35	4.6	37.4	28.0	0.75	2.24	45.0	16.7	2.9
90	5.0	0.7	1.6	51.2	2.68	42.1	109.3	5.60	4.9	34.5	26.3	0.76	2.66	43.6	13.0	3.9
	7.0	1.8	4.2	52.0	2.72	42.8	109.9	5.61	5.1	35.1	27.0	0.77	2.54	43.8	13.8	3.7
	9.0	5.3	12.3	52.8	2.75	43.5	110.5	5.63	5.2	35.8	27.5	0.77	2.46	44.2	14.6	3.6
100	5.0	0.6	1.3	Operation not recommended						Operation not recommended						
	7.0	1.7	4.0	Operation not recommended						33.3	26.4	0.79	2.86	43.0	11.7	4.6
	9.0	5.2	12.0	Operation not recommended						33.8	26.6	0.79	2.77	43.2	12.2	4.4
110	5.0	0.5	1.1	Operation not recommended						Operation not recommended						
	7.0	1.6	3.7	Operation not recommended						31.2	25.3	0.81	3.16	41.9	9.9	5.7
	9.0	5.1	11.8	Operation not recommended						31.8	25.7	0.81	3.07	42.3	10.4	5.4
120	5.0	0.4	0.8	Operation not recommended						Operation not recommended						
	7.0	1.5	3.5	Operation not recommended						26.5	22.7	0.85	3.53	38.6	7.5	6.8
	9.0	5.0	11.5	Operation not recommended						27.1	23.0	0.85	3.43	38.8	7.9	6.4

11/10/09

YG041 - Performance Data

Single Speed Variable Speed ECM or 5-Speed ECM (1300 cfm)

EWT °F	Flow gpm	WPD		HEATING - EAT 70°F						COOLING - EAT 80/67°F						
		psi	ft. hd.	HC MBtu/h	Power kW	HE MBtu/h	LAT °F	COP	HWC MBtu/h	TC MBtu/h	SC MBtu/h	S/T Ratio	Power kW	HR MBtu/h	EER	HWC MBtu/h
20	5.0	1.6	3.8	Operation not recommended						Operation not recommended						
	8.0	3.6	8.2	Operation not recommended						Operation not recommended						
	11.0	8.0	18.5	25.7	2.61	16.8	85.0	2.89	3.5							
30	5.0	1.5	3.4	Operation not recommended						Operation not recommended						
	8.0	3.4	7.8	28.5	2.61	19.6	86.9	3.20	3.7	41.8	30.4	0.73	1.71	47.7	24.5	---
	11.0	7.9	18.1	29.5	2.66	20.4	87.5	3.26	3.8	42.4	31.0	0.73	1.61	47.9	26.4	---
40	5.0	1.3	3.0	Operation not recommended						Operation not recommended						
	8.0	3.2	7.5	31.7	2.67	22.6	89.0	3.48	4.0	43.8	31.4	0.72	1.85	50.2	23.7	---
	11.0	7.7	17.8	33.1	2.71	23.8	89.9	3.58	4.1	44.5	31.9	0.72	1.75	50.4	25.5	---
50	5.0	1.2	2.7	33.7	2.72	24.4	90.3	3.64	4.4	45.2	32.0	0.71	2.11	52.4	21.5	2.4
	8.0	3.1	7.1	35.2	2.74	25.8	91.2	3.77	4.5	45.9	32.4	0.71	2.00	52.7	23.0	2.4
	11.0	7.5	17.4	36.6	2.76	27.2	92.2	3.89	4.7	46.5	32.7	0.70	1.89	52.9	24.7	2.3
60	5.0	1.0	2.3	37.9	2.78	28.4	93.0	3.99	5.0	44.2	31.5	0.71	2.36	52.2	18.7	3.0
	8.0	2.9	6.7	39.3	2.80	29.7	94.0	4.11	5.1	45.1	31.8	0.70	2.23	52.7	20.3	2.8
	11.0	7.4	17.0	40.7	2.82	31.1	94.9	4.23	5.3	46.1	32.1	0.70	2.09	53.2	22.1	2.7
70	5.0	0.9	2.0	42.0	2.85	32.3	95.8	4.33	5.6	43.1	30.9	0.72	2.62	52.0	16.5	3.8
	8.0	2.8	6.4	43.4	2.87	33.6	96.7	4.44	5.7	44.4	31.2	0.70	2.46	52.8	18.1	3.6
	11.0	7.2	16.7	44.8	2.89	35.0	97.6	4.55	5.9	45.7	31.5	0.69	2.30	53.5	19.9	3.4
80	5.0	0.7	1.6	46.9	2.91	37.0	99.0	4.73	6.3	41.7	30.4	0.73	2.80	51.2	14.9	4.8
	8.0	2.6	6.0	48.0	2.94	38.0	99.8	4.79	6.5	42.6	30.6	0.72	2.67	51.7	16.0	4.5
	11.0	7.1	16.3	49.2	2.97	39.0	100.5	4.85	6.7	43.7	30.8	0.70	2.59	52.5	16.9	4.3
90	5.0	0.5	1.2	51.9	2.98	41.7	102.3	5.11	7.1	40.2	29.8	0.74	3.11	50.9	12.9	6.0
	8.0	2.5	5.7	52.7	3.02	42.4	102.9	5.12	7.3	40.9	30.0	0.73	2.97	51.0	13.8	5.7
	11.0	6.9	16.0	53.5	3.06	43.1	103.4	5.13	7.5	41.7	30.1	0.72	2.88	51.5	14.5	5.5
100	5.0	0.4	0.9	Operation not recommended						Operation not recommended						
	8.0	2.3	5.3	Operation not recommended						38.2	29.0	0.76	3.34	49.6	11.4	7.1
	11.0	6.8	15.6	Operation not recommended						38.8	29.2	0.75	3.24	49.8	12.0	6.8
110	5.0	0.4	0.9	Operation not recommended						Operation not recommended						
	8.0	2.1	4.9	Operation not recommended						35.2	27.9	0.79	3.70	47.8	9.5	8.6
	11.0	6.6	15.2	Operation not recommended						35.9	28.3	0.79	3.60	48.2	10.0	8.3
120	5.0	0.4	0.9	Operation not recommended						Operation not recommended						
	8.0	2.0	4.6	Operation not recommended						31.8	27.1	0.85	4.34	46.6	7.3	10.4
	11.0	6.5	14.9	Operation not recommended						32.5	27.5	0.85	4.22	46.9	7.7	10.0

YG042 - Performance Data

Single Speed Variable Speed ECM or 5-Speed ECM (1400 cfm)

EWT °F	Flow gpm	WPD		HEATING - EAT 70°F						COOLING - EAT 80/67°F						
		psi	ft. hd.	HC MBtu/h	Power kW	HE MBtu/h	LAT °F	COP	HWC MBtu/h	TC MBtu/h	SC MBtu/h	S/T Ratio	Power kW	HR MBtu/h	EER	HWC MBtu/h
20	5.0	1.6	3.8	Operation not recommended						Operation not recommended						
	8.0	3.6	8.2	Operation not recommended						Operation not recommended						
	11.0	8.0	18.5	27.0	2.61	18.1	85.9	3.04	3.5							
30	5.0	1.5	3.4	Operation not recommended						Operation not recommended						
	8.0	3.4	7.8	30.0	2.61	21.1	87.8	3.37	3.7	43.6	31.7	0.73	1.71	49.4	25.5	---
	11.0	7.9	18.1	31.0	2.66	21.9	88.5	3.42	3.8	44.2	32.3	0.73	1.61	49.7	27.5	---
40	5.0	1.3	3.0	Operation not recommended						Operation not recommended						
	8.0	3.2	7.5	33.4	2.67	24.2	90.1	3.66	4.0	45.7	32.7	0.72	1.85	52.0	24.7	---
	11.0	7.7	17.8	34.8	2.71	25.5	91.0	3.77	4.1	46.3	33.2	0.72	1.75	52.3	26.5	---
50	5.0	1.2	2.7	35.5	2.72	26.2	91.5	3.83	4.4	47.1	33.4	0.71	2.11	54.3	22.4	2.4
	8.0	3.1	7.1	37.0	2.74	27.7	92.5	3.96	4.5	47.8	33.8	0.71	2.00	54.6	23.9	2.4
	11.0	7.5	17.4	38.5	2.76	29.1	93.5	4.10	4.7	48.4	34.1	0.70	1.89	54.8	25.7	2.3
60	5.0	1.0	2.3	39.9	2.78	30.4	94.4	4.20	5.0	46.0	32.8	0.71	2.36	54.1	19.5	3.0
	8.0	2.9	6.7	41.4	2.80	31.8	95.3	4.33	5.1	47.0	33.1	0.70	2.23	54.6	21.1	2.8
	11.0	7.4	17.0	42.9	2.82	33.2	96.3	4.45	5.3	48.0	33.5	0.70	2.09	55.1	23.0	2.7
70	5.0	0.9	2.0	44.2	2.85	34.5	97.2	4.55	5.6	44.9	32.2	0.72	2.62	53.8	17.2	3.8
	8.0	2.8	6.4	45.7	2.87	35.9	98.2	4.68	5.7	46.3	32.5	0.70	2.46	54.6	18.8	3.6
	11.0	7.2	16.7	47.2	2.89	37.4	99.2	4.79	5.9	47.6	32.8	0.69	2.30	55.4	20.7	3.4
80	5.0	0.7	1.6	49.4	2.91	39.5	100.7	4.97	6.3	43.4	31.6	0.73	2.80	53.0	15.5	4.8
	8.0	2.6	6.0	50.6	2.94	40.5	101.5	5.04	6.5	44.4	31.9	0.72	2.67	53.6	16.6	4.5
	11.0	7.1	16.3	51.8	2.97	41.6	102.2	5.11	6.7	45.6	32.1	0.70	2.59	54.4	17.6	4.3
90	5.0	0.5	1.2	54.6	2.98	44.4	104.1	5.37	7.1	42.0	31.0	0.74	3.11	52.6	13.5	6.0
	8.0	2.5	5.7	55.5	3.02	45.2	104.7	5.39	7.3	42.6	31.2	0.73	2.97	52.8	14.3	5.7
	11.0	6.9	16.0	56.3	3.06	45.9	105.2	5.40	7.5	43.5	31.4	0.72	2.88	53.3	15.1	5.5
100	5.0	0.4	0.9	Operation not recommended						Operation not recommended						
	8.0	2.3	5.3	Operation not recommended						39.8	30.2	0.76	3.34	51.2	11.9	7.1
	11.0	6.8	15.6	Operation not recommended						40.5	30.5	0.75	3.24	51.5	12.5	6.8
110	5.0	0.4	0.9	Operation not recommended						Operation not recommended						
	8.0	2.1	4.9	Operation not recommended						36.7	29.1	0.79	3.70	49.3	9.9	8.6
	11.0	6.6	15.2	Operation not recommended						37.4	29.5	0.79	3.60	49.7	10.4	8.3
120	5.0	0.4	0.9	Operation not recommended						Operation not recommended						
	8.0	2.0	4.6	Operation not recommended						33.2	28.2	0.85	4.34	48.0	7.6	10.4
	11.0	6.5	14.9	Operation not recommended						33.9	28.6	0.84	4.22	48.3	8.0	10.0

11/10/09

YG048 - Performance Data

Single Speed Variable Speed ECM or 5-Speed ECM (1600 cfm)

EWT °F	Flow gpm	WPD		HEATING - EAT 70°F						COOLING - EAT 80/67°F						
		psi	ft. hd.	HC MBtu/h	Power kW	HE MBtu/h	LAT °F	COP	HWC MBtu/h	TC MBtu/h	SC MBtu/h	S/T Ratio	Power kW	HR MBtu/h	EER	HWC MBtu/h
20	6.0	2.2	5.1	Operation not recommended						Operation not recommended						
	9.0	4.4	10.0	Operation not recommended						Operation not recommended						
	12.0	6.8	15.8	30.8	3.09	20.2	87.0	2.92	4.6							
30	6.0	2.0	4.7	Operation not recommended						Operation not recommended						
	9.0	4.2	9.6	35.3	3.12	24.6	89.8	3.31	4.9	50.3	31.3	0.62	2.09	57.4	24.1	---
	12.0	6.7	15.5	35.8	3.15	25.1	90.1	3.33	5.0	51.0	31.9	0.63	1.96	57.7	26.0	---
40	6.0	1.9	4.3	Operation not recommended						Operation not recommended						
	9.0	4.0	9.2	40.1	3.25	29.0	92.8	3.62	5.4	53.1	34.8	0.65	2.29	60.9	23.2	---
	12.0	6.5	15.0	41.9	3.29	30.7	93.9	3.74	5.5	54.0	35.5	0.66	2.16	61.4	25.0	---
50	6.0	1.7	3.9	42.9	3.32	31.6	94.5	3.79	5.9	54.9	37.4	0.68	2.61	63.8	21.0	2.9
	9.0	3.8	8.8	45.5	3.38	34.0	96.1	3.95	6.1	56.0	38.3	0.68	2.49	64.4	22.5	2.8
	12.0	6.3	14.6	48.1	3.43	36.4	97.7	4.11	6.2	57.0	39.1	0.69	2.36	65.1	24.1	2.7
60	6.0	1.5	3.5	49.5	3.47	37.7	98.6	4.18	6.7	54.5	37.4	0.69	2.91	64.4	18.7	3.5
	9.0	3.6	8.4	52.2	3.52	40.2	100.2	4.35	6.8	55.4	38.0	0.69	2.76	64.8	20.0	3.4
	12.0	6.1	14.1	54.9	3.56	42.8	101.9	4.52	7.0	56.2	38.6	0.69	2.62	65.1	21.5	3.2
70	6.0	1.3	3.0	56.1	3.62	43.7	102.6	4.54	7.5	54.1	37.3	0.69	3.20	65.0	16.9	4.5
	9.0	3.5	8.0	58.9	3.65	46.5	104.4	4.73	7.7	54.8	37.7	0.69	3.04	65.1	18.0	4.3
	12.0	5.9	13.7	61.7	3.68	49.2	106.1	4.91	7.9	55.4	38.2	0.69	2.87	65.2	19.3	4.0
80	6.0	1.1	2.6	61.3	3.70	48.7	105.8	4.86	8.4	51.4	35.8	0.70	3.48	63.2	14.8	5.6
	9.0	3.3	7.6	63.2	3.74	50.5	107.0	4.96	8.6	52.1	36.4	0.70	3.31	63.4	15.7	5.3
	12.0	5.8	13.3	65.2	3.78	52.3	108.2	5.05	8.9	52.9	36.9	0.70	3.21	63.9	16.5	5.1
90	6.0	1.0	2.2	66.5	3.78	53.6	109.1	5.16	9.4	48.7	34.3	0.70	3.84	61.8	12.7	7.0
	9.0	3.1	7.1	67.5	3.83	54.5	109.7	5.17	9.7	49.4	35.0	0.71	3.66	61.9	13.5	6.7
	12.0	5.6	12.9	68.6	3.87	55.4	110.3	5.19	10.1	50.4	35.6	0.70	3.54	62.5	14.2	6.4
100	6.0	0.8	1.8	Operation not recommended						Operation not recommended						
	9.0	2.9	6.7	Operation not recommended						46.7	34.3	0.74	4.14	60.8	11.3	8.4
	12.0	5.4	12.5	Operation not recommended						47.4	34.6	0.73	4.00	61.0	11.8	8.0
110	6.0	0.6	1.4	Operation not recommended						Operation not recommended						
	9.0	2.7	6.3	Operation not recommended						43.4	33.2	0.76	4.59	59.1	9.5	10.3
	12.0	5.2	12.1	Operation not recommended						44.3	33.7	0.76	4.46	59.5	9.9	9.7
120	6.0	0.4	1.0	Operation not recommended						Operation not recommended						
	9.0	2.6	5.9	Operation not recommended						40.1	32.0	0.80	5.16	57.7	7.8	12.4
	12.0	5.0	11.6	Operation not recommended						41.0	32.5	0.79	5.01	58.1	8.2	11.8

YG060 - Performance Data

Single Speed Variable Speed ECM or 5-Speed ECM (2000 cfm)

EWT °F	Flow gpm	WPD		HEATING - EAT 70°F						COOLING - EAT 80/67°F						
		psi	ft. hd.	HC MBtu/h	Power kW	HE MBtu/h	LAT °F	COP	HWC MBtu/h	TC MBtu/h	SC MBtu/h	S/T Ratio	Power kW	HR MBtu/h	EER	HWC MBtu/h
20	9.0	3.8	8.7	Operation not recommended						Operation not recommended						
	12.0	6.3	14.5	Operation not recommended						Operation not recommended						
	15.0	9.7	22.5	41.9	3.96	28.4	87.4	3.10	5.5	Operation not recommended						
30	9.0	3.6	8.4	Operation not recommended						Operation not recommended						
	12.0	6.1	14.1	43.8	3.89	30.5	88.3	3.30	5.9	72.0	49.1	0.68	2.86	81.8	25.2	---
	15.0	9.6	22.2	46.5	4.01	32.8	89.5	3.39	6.1	73.0	50.0	0.68	2.68	82.2	27.2	---
40	9.0	3.5	8.0	Operation not recommended						Operation not recommended						
	12.0	6.0	13.7	49.7	4.03	35.9	91.0	3.62	6.6	70.8	48.8	0.69	3.01	81.0	23.5	---
	15.0	9.4	21.7	52.2	4.12	38.1	92.2	3.71	6.7	71.8	49.5	0.69	2.87	81.6	25.0	---
50	9.0	3.3	7.6	54.6	4.10	40.6	93.3	3.90	7.1	68.5	48.0	0.70	3.24	79.6	21.1	3.9
	12.0	5.8	13.4	56.2	4.16	42.0	94.0	3.96	7.3	69.5	48.5	0.70	3.15	80.3	22.0	3.7
	15.0	9.2	21.3	57.8	4.22	43.4	94.8	4.01	7.5	70.5	48.9	0.69	3.06	81.0	23.0	3.5
60	9.0	3.1	7.3	62.2	4.25	47.7	96.8	4.28	8.0	67.3	47.0	0.70	3.54	79.3	19.0	4.8
	12.0	5.6	13.0	64.3	4.31	49.6	97.8	4.37	8.3	68.2	47.6	0.70	3.44	79.9	19.8	4.6
	15.0	9.1	21.0	66.4	4.36	51.5	98.8	4.46	8.5	69.1	48.3	0.70	3.35	80.5	20.6	4.4
70	9.0	3.0	6.9	69.8	4.40	54.8	100.3	4.64	9.0	66.0	46.0	0.70	3.83	79.1	17.2	6.0
	12.0	5.5	12.6	72.4	4.45	57.2	101.5	4.76	9.3	66.9	46.8	0.70	3.73	79.6	17.9	5.7
	15.0	8.9	20.6	75.0	4.50	59.6	102.7	4.88	9.5	67.7	47.6	0.70	3.63	80.1	18.6	5.4
80	9.0	2.8	6.5	76.2	4.50	60.9	103.3	4.97	10.2	62.2	45.0	0.72	4.35	77.0	14.3	7.6
	12.0	5.3	12.3	78.2	4.55	62.7	104.2	5.04	10.5	63.1	45.7	0.72	4.15	77.2	15.2	7.2
	15.0	8.8	20.2	80.1	4.60	64.4	105.1	5.10	10.7	64.1	46.3	0.72	4.01	77.8	16.0	6.8
90	9.0	2.7	6.1	82.7	4.59	67.1	106.3	5.29	11.4	58.4	43.9	0.75	4.76	74.7	12.3	9.5
	12.0	5.2	11.9	84.0	4.65	68.1	106.9	5.30	11.8	59.3	44.6	0.75	4.54	74.8	13.1	9.0
	15.0	8.6	19.9	85.3	4.70	69.2	107.5	5.31	12.2	60.5	45.0	0.74	4.39	75.5	13.8	8.6
100	9.0	2.5	5.8	Operation not recommended						Operation not recommended						
	12.0	5.0	11.5	Operation not recommended						56.1	43.4	0.77	5.05	73.4	11.1	11.2
	15.0	8.4	19.5	Operation not recommended						57.0	43.7	0.77	4.89	73.7	11.7	10.6
110	9.0	2.3	5.4	Operation not recommended						Operation not recommended						
	12.0	4.8	11.2	Operation not recommended						52.3	41.8	0.80	5.53	71.2	9.5	13.8
	15.0	8.3	19.1	Operation not recommended						53.4	42.4	0.79	5.38	71.8	9.9	13.1
120	9.0	2.2	5.0	Operation not recommended						Operation not recommended						
	12.0	4.7	10.8	Operation not recommended						48.0	39.9	0.83	6.15	69.0	7.8	16.6
	15.0	8.1	18.8	Operation not recommended						49.0	40.5	0.83	5.97	69.4	8.2	15.9

7/6/10

YG070 - Performance Data

Single Speed Variable Speed ECM or 5-Speed ECM (2200 cfm)

EWT °F	Flow gpm	WPD		HEATING - EAT 70°F						COOLING - EAT 80/67°F						
		psi	ft. hd.	HC MBtu/h	Power kW	HE MBtu/h	LAT °F	COP	HWC MBtu/h	TC MBtu/h	SC MBtu/h	S/T Ratio	Power kW	HR MBtu/h	EER	HWC MBtu/h
20	12.0	4.3	9.8	Operation not recommended						Operation not recommended						
	15.0	5.6	13.0	Operation not recommended						Operation not recommended						
	18.0	9.0	20.8	46.0	4.88	29.3	87.4	2.76	6.5							
30	12.0	4.1	9.4	Operation not recommended						Operation not recommended						
	15.0	5.9	13.6	52.0	4.82	35.5	89.9	3.16	7.0	73.0	46.1	0.63	3.18	83.9	22.9	---
	18.0	8.8	20.3	53.7	4.96	36.8	90.6	3.17	7.3	74.0	47.0	0.64	2.99	84.2	24.7	---
40	12.0	3.8	8.8	Operation not recommended						Operation not recommended						
	15.0	5.2	12.0	58.4	5.00	41.3	92.6	3.42	7.8	74.6	49.3	0.66	3.38	86.1	22.1	---
	18.0	8.6	19.8	60.9	5.10	43.5	93.6	3.50	8.0	76.1	50.5	0.66	3.25	87.2	23.4	---
50	12.0	3.6	8.4	62.8	5.15	45.2	94.4	3.57	8.5	74.2	51.0	0.69	3.64	86.6	20.4	4.3
	15.0	5.0	11.5	65.4	5.19	47.7	95.5	3.69	8.7	76.2	52.5	0.69	3.58	88.4	21.3	4.1
	18.0	8.4	19.3	68.0	5.23	50.2	96.6	3.81	8.9	78.2	54.0	0.69	3.51	90.2	22.3	3.9
60	12.0	3.4	7.9	71.9	5.36	53.6	98.3	3.94	9.5	71.6	50.0	0.70	3.98	85.2	18.0	5.2
	15.0	4.8	11.0	73.9	5.39	55.6	99.1	4.02	9.8	73.3	51.3	0.70	3.90	86.6	18.8	4.9
	18.0	8.2	18.8	76.0	5.42	57.5	100.0	4.11	10.1	75.1	52.5	0.70	3.82	88.1	19.7	4.8
70	12.0	3.2	7.4	81.0	5.56	62.0	102.1	4.27	10.7	69.0	49.0	0.71	4.31	83.7	16.0	6.6
	15.0	4.6	10.5	82.5	5.59	63.4	102.7	4.33	11.0	70.5	50.0	0.71	4.22	84.9	16.7	6.3
	18.0	7.9	18.3	84.0	5.61	64.8	103.3	4.39	11.3	71.9	51.0	0.71	4.13	86.0	17.4	6.0
80	12.0	3.0	6.9	89.7	5.72	70.2	105.8	4.59	12.1	65.3	47.4	0.73	4.93	82.1	13.2	8.3
	15.0	4.4	10.0	91.2	5.78	71.5	106.4	4.63	12.4	66.5	48.3	0.73	4.71	82.6	14.1	7.9
	18.0	7.7	17.9	92.7	5.83	72.9	107.0	4.67	12.8	67.9	49.0	0.72	4.56	83.4	14.9	7.5
90	12.0	2.8	6.4	98.4	5.89	78.3	109.4	4.90	13.6	61.6	45.8	0.74	5.39	80.0	11.4	10.4
	15.0	4.1	9.5	99.9	5.97	79.6	110.1	4.91	14.0	62.5	46.6	0.75	5.15	80.1	12.2	9.9
	18.0	7.5	17.3	101.5	6.04	80.9	110.7	4.92	14.4	63.8	47.0	0.74	4.98	80.8	12.8	9.4
100	12.0	2.5	5.9	Operation not recommended						Operation not recommended						
	15.0	3.9	9.1	Operation not recommended						59.7	44.9	0.75	5.73	79.2	10.4	12.4
	18.0	7.3	16.9	Operation not recommended						60.6	45.3	0.75	5.55	79.5	10.9	11.7
110	12.0	2.3	5.4	Operation not recommended						Operation not recommended						
	15.0	3.7	8.5	Operation not recommended						56.2	42.9	0.76	6.28	77.6	8.9	15.1
	18.0	7.1	16.4	Operation not recommended						57.4	43.5	0.76	6.11	78.2	9.4	14.3
120	12.0	2.1	4.9	Operation not recommended						Operation not recommended						
	15.0	3.5	8.1	Operation not recommended						51.9	41.4	0.80	6.98	75.7	7.4	18.2
	18.0	6.9	15.9	Operation not recommended						53.0	42.0	0.79	6.78	76.1	7.8	17.3

Wiring Schematics

Commercial Aurora with PSC Motor & Soft Start 208-230/60/1

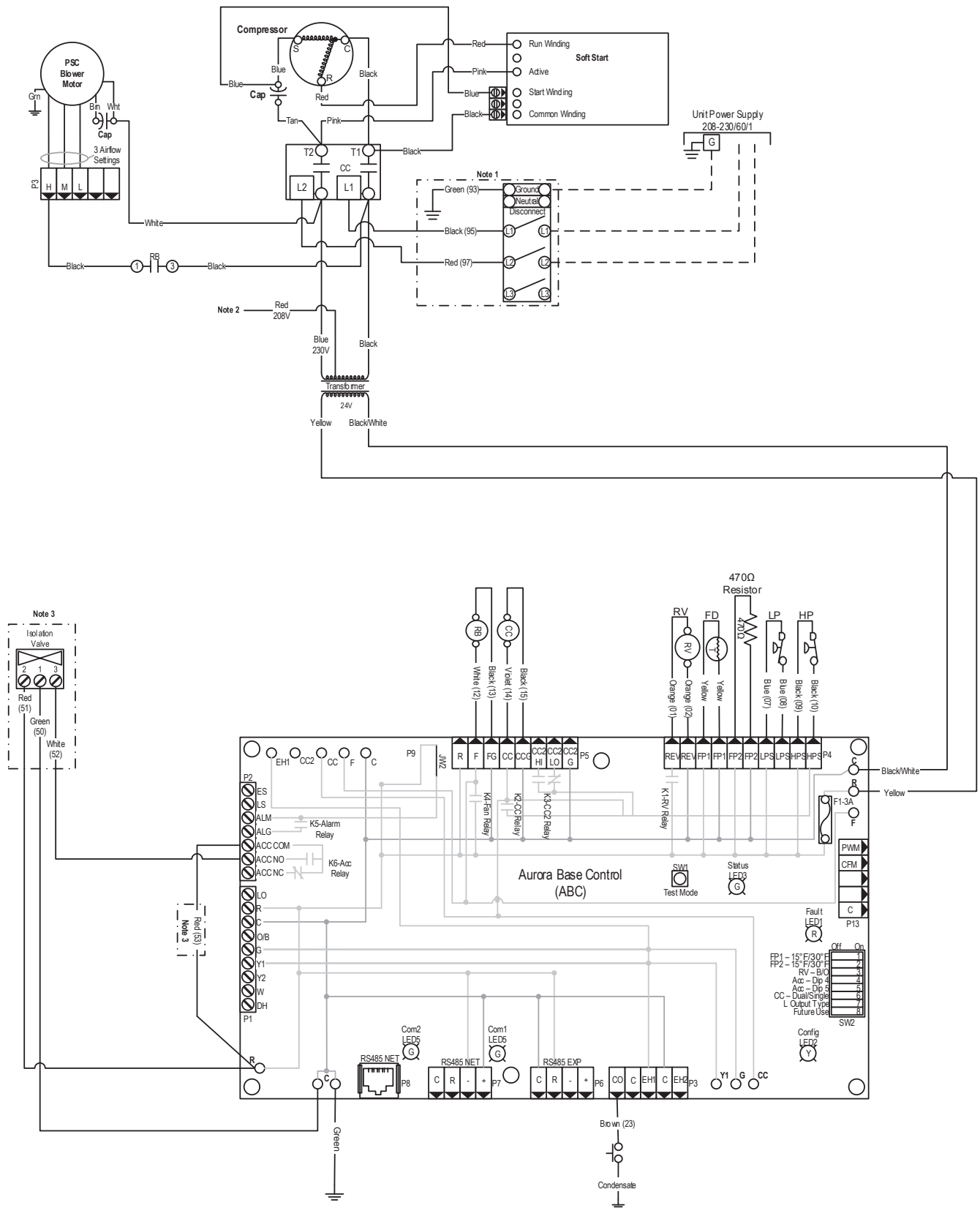

Wiring Schematics cont.

Commercial Aurora with PSC Motor & Soft Start 208-230/60/1

Notes:

- 1 – Optional, factory installed unit mounted disconnect.
- 2 – Swap blue and red leads for 208V operation.
- 3 – Optional, factory installed internal isolation valve.

Legend

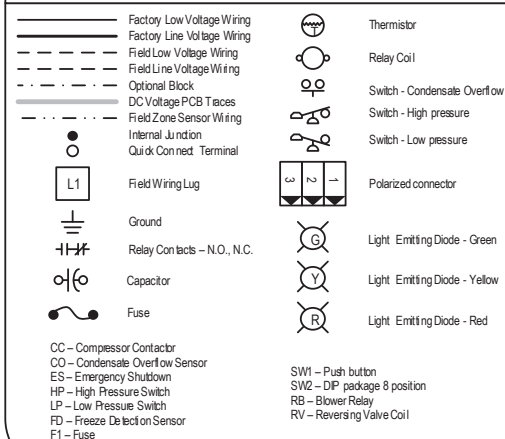

Aurora LED Flash Codes			
Slow Flash	1 second on and 1 second off		
Fast Flash	100 milliseconds on and 100 milliseconds off		
Flash Code	100 milliseconds on and 400 milliseconds off with a 2 second pause before repeating		
Random Start Delay			
Status LED (LED1, Green)	Fast Flash		
Configuration LED (LED2, Yellow)	Fast Flash		
Fault LED (LED3, Red)	Fast Flash		
Status LED (LED1, Green)	Configuration LED (LED2, Yellow)	Fault LED (LED3, Red)	
Normal Mode	ON	No Software Override	Flash EOM Setting
Control is Non-Functional	OFF	DIP Switch Override	Slow Flash
Test Mode	Slow Flash	ECM Configure Mode	Fast Flash
Lockout Active	Fast Flash	Reset Configure Mode	Off
Dehumidification Mode	Flash Code 2	Low Air Coil Limit Lockout - FP2	
Resened	Flash Code 3	Low Water Coil Limit Lockout - FP1	
Resened	Flash Code 4	Resened	
Load Shed	Flash Code 5	Condensate Overflow Lockout	
ESD	Flash Code 6	Over/Under Voltage Shutdown	
Reserved	Flash Code 7	Resened	
		Resened	
		Air/Water Coil Limit Sensor Error	

Aurora Timing Events		
Event	Normal Mode	Test Mode
Random Start Delay	5 to 80 seconds	1 second
Compressor On Delay	5 seconds	< 1 second
Compressor Minimum On Time	2 minutes	5 seconds
Compressor Short Cycle Delay	4 minutes	15 seconds
Blower Off Delay	30 seconds	2 seconds
Fault Recognition Delay – High Pressure	Less than 1 second	Less than 1 second
Start-Up Bypass – Low Pressure	2 minutes	30 seconds
Fault Recognition Delay – Low Pressure	30 seconds	30 seconds
Start-Up Bypass – Low Water/Air Coil Limit	2 minutes	30 seconds
Fault Recognition Delay – Low Water/Air Coil Limit	30 seconds	30 seconds
Fault Recognition Delay – Condensate Overflow	30 seconds	30 seconds
Thermostat Call Recognition Time	2 seconds	2 seconds
Auxiliary Heat Staging Delay	5 minutes	20 seconds
Emergency Heat Staging Delay	2 minutes	7.5 seconds
Water Valve Slow Open Delay	90 seconds	90 seconds
Reheat Delay	30 seconds	30 seconds

Accessory Relay			
Operation	SW2-4	SW2-5	
Cycle with Blower	On	On	
Cycle with Compressor	Off	Off	
Water Valve Slow Open	On	Off	
Outdoor Air Damper	Off	On	

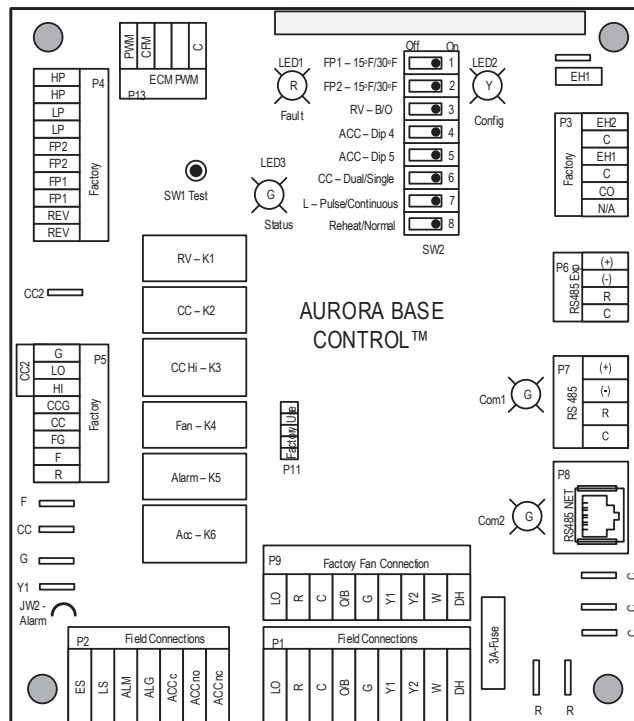

Wiring Schematics

Commercial Aurora Base with 5-Speed ECM and Hot Gas Reheat - 460/60/3

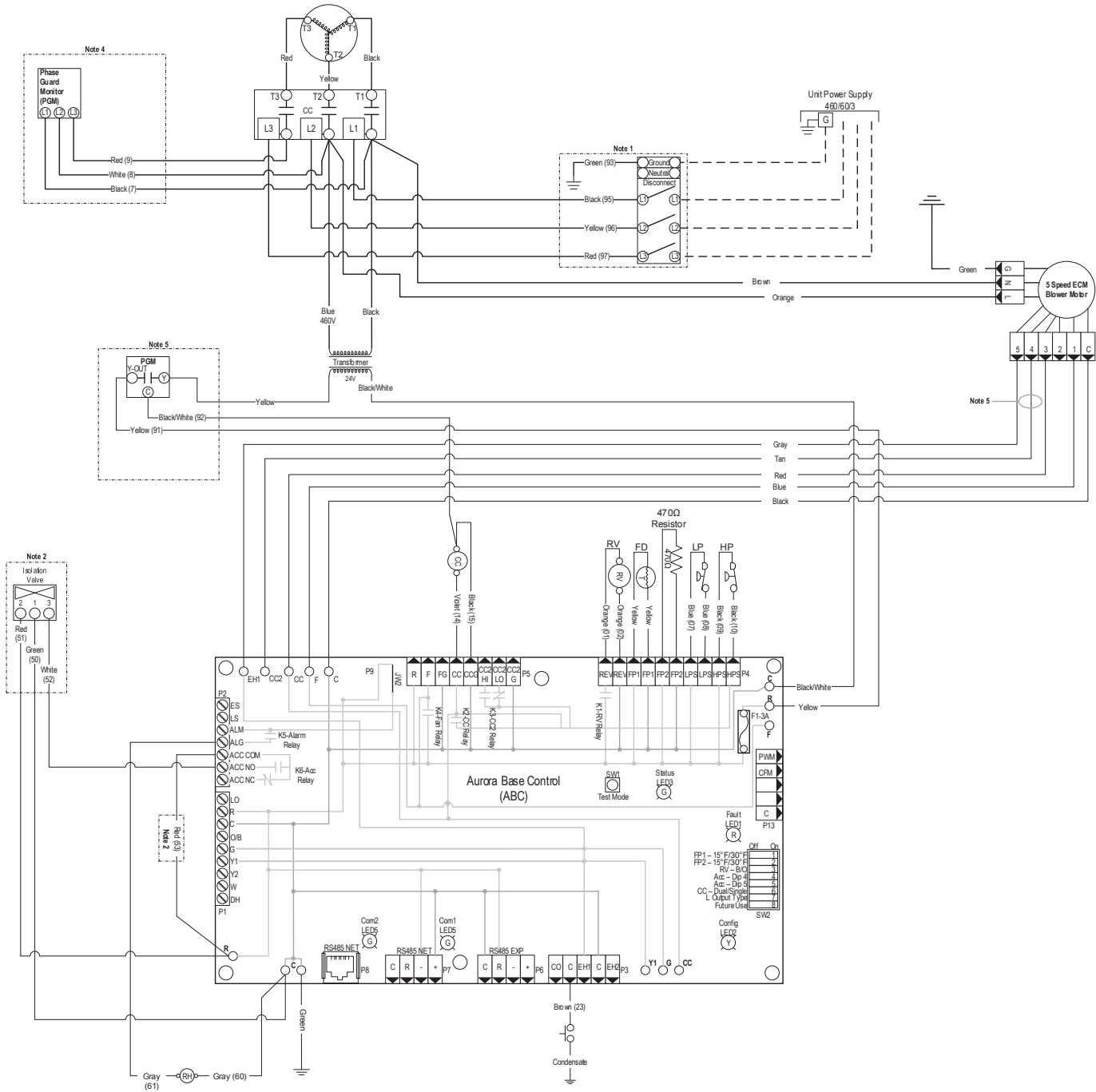

Wiring Schematics cont.

Commercial Aurora Base with 5-Speed ECM and Hot Gas Reheat - 460/60/3

97P819-08
10/30/12

Notes:

- 1 - Optional, factory installed unit mounted disconnect.
- 2 - Optional, factory installed internal isolation valve.
- 3 - Optional, factory installed phase guard.
- 4 - Optional, factory installed phase guard. The yellow transformer wire shall be connected directly to the CPU board, if this option is not installed.
- 5 - Wire is provided with the unit but not connected to the 5-Speed ECM motor.

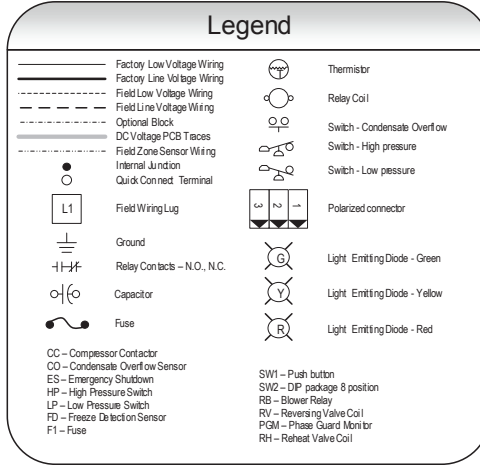

Aurora LED Flash Codes					
Slow Flash	1 second on and 1 second off				
Fast Flash	100 milliseconds on and 100 milliseconds off				
Flash Code	100 milliseconds on and 400 milliseconds off with a 2 second pause before repeating				
Random Start Delay					
Status LED (LED1, Green)	Fast Flash				
Configuration LED (LED2, Yellow)	Fast Flash				
Fault LED (LED3, Red)	Fast Flash				
Status LED (LED1, Green)	Configuration LED (LED2, Yellow)	Fault LED (LED3, Red)			
Normal Mode	ON	No Software Override	Flash ECM Setting	Normal Mode	OFF
Control is Non-Functional	OFF	DIP Software Override	Slow Flash	Input Fault Lockout	Flash Code 1
Test Mode	Slow Flash	ECM Configure Mode	Fast Flash	High Pressure Lockout	Flash Code 2
Lockout Active	Fast Flash	Reset Configure Mode	Off	Low Pressure Lockout	Flash Code 3
Dehumidification Mode	Flash Code 2			Low Air Coil Limit Lockout - FP2	Flash Code 4
Reserved	Flash Code 3			Low Water Coil Limit Lockout - FP1	Flash Code 5
Reserved	Flash Code 4			Reserved	Flash Code 6
Load Shed	Flash Code 5			Condensate Overflow Lockout	Flash Code 7
ESD	Flash Code 6			Over/Under Voltage Shutdown	Flash Code 8
Reserved	Flash Code 7			Reserved	Flash Code 9
				Reserved	Flash Code 10
				Air/Water Coil Limit Sensor Error	Flash Code 11

Accessory Relay		
Operation	SW2-4	SW2-5
Cycle with Blower	On	On
Cycle with Compressor	Off	Off
Water Valve Slow Open	On	Off
Outdoor Air Damper	Off	On

Aurora Timing Events		
Event	Normal Mode	Test Mode
Random Start Delay	5 to 80 seconds	1 second
Compressor On Delay	5 seconds	< 1 second
Compressor Minimum On Time	2 minutes	5 seconds
Compressor Short Cycle Delay	4 minutes	15 seconds
Blower Off Delay	30 seconds	2 seconds
Fault Reopen Delay - High Pressure	Less than 1 second	Less than 1 second
Start-Up Bypass - Low Pressure	2 minutes	30 seconds
Fault Reopen Delay - Low Pressure	30 seconds	30 seconds
Start-Up Bypass - Low Water/Air Coil Limit	2 minutes	30 seconds
Fault Reopen Delay - Low Water/Air Coil Limit	30 seconds	30 seconds
Fault Reopen Delay - Condensate Overflow	30 seconds	30 seconds
Thermostat Call Recognition Time	2 seconds	2 seconds
Auxiliary Heat Staging Delay	5 minutes	20 seconds
Emergency Heat Staging Delay	2 minutes	7.5 seconds
Water Valve Slow Open Delay	90 seconds	90 seconds
Reheat Delay	30 seconds	30 seconds

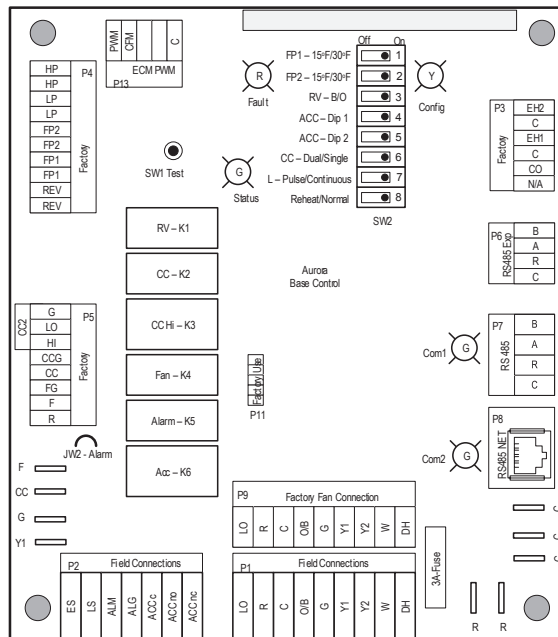

Engineering Guide Specifications

General

Furnish and install York water source heat pumps as indicated on the plans. Equipment shall be completely assembled, piped and internally wired. Capacities and characteristics as listed in the schedule and the specifications that follow. The reverse cycle heating/cooling units shall be either suspended type with horizontal air inlet and discharge or floor mounted type with horizontal air inlet and vertical upflow air discharge. Units shall be AHRI/ISO 13256-1 certified and listed by a nationally recognized safety-testing laboratory or agency, such as ETL Testing Laboratory. Each unit shall be computer run-tested at the factory with conditioned water and operation verified to catalog data. Each unit shall be mounted on a pallet and shipped in a corrugated box or stretch-wrapped. The units shall be designed to operate with entering liquid temperature between 20°F and 120°F [-6.7°C and 48.9°C].

Casing and Cabinet

The cabinet shall be fabricated from heavy-gauge galvanized steel and finished with optional corrosion-resistant powder coating. This corrosion protection system shall meet the stringent 1000 hour salt spray test per ASTM B117. The interior shall be insulated with 1/2 in. thick, multi-density, cleanable aluminum foil coated glass fiber with edges sealed or tucked under flanges to prevent the introduction of glass fibers into the discharge air. Standard cabinet panel insulation must meet NFPA 90A requirements, air erosion and mold growth limits of UL-181, stringent fungal resistance test per ASTM-C1071 and ASTM G21, and shall meet zero level bacteria growth per ASTM G22. Unit insulation must meet these stringent requirements or unit(s) will not be accepted.

One (horizontal) to two (vertical) blower and two compressor compartment access panels shall be 'lift-out' removable with supply and return ductwork in place.

A duct collar shall be provided on the supply air opening. Standard size 1 in. [2.54 cm] MERV 4 filters shall be provided with each unit. Units shall have a return air filter rack that is field convertible from 1 in. [2.54 cm] to 2 in. [5.1 cm]. The upflow vertical units shall have a removable insulated divider panel between the air handling section and the compressor section to minimize the transmission of compressor noise and to permit operational service testing without air bypass. Vertical units shall be supplied with left or right horizontal air inlet and top vertical air discharge. Horizontal units shall be supplied with left or right air inlet and side or end air discharge.

The compressor shall be double isolation mounted using selected durometer grommets to provide vibration free compressor mounting. The compressor mounting bracket shall be acoustically deadened galvanized steel to prevent vibration transmission to the cabinet.

Option: AlpinePure MERV 13 Filter - A 2 in. thick [51 mm] MERV 13 filter can help fulfill a credit under the LEED Rating System. Its low initial resistance promotes low energy consumption (0.21 in. w.g. @ 300 fpm) and provides nearly twice the life of a standard filter (300 fpm vs. standard 500 fpm application).

Option: A Super Quiet Sound package shall include multi-density full coverage compressor blanket.

Option: An internally mounted low pressure drop (high Cv) water solenoid valve shall be factory installed for use in variable speed pumping applications.

Option: An internally mounted automatic flow regulator shall be set to 3 gpm/ton to deliver optimal flow to the unit.

Refrigerant Circuit

All units shall utilize the non-ozone depleting and low global warming potential refrigerant R-410A. All units shall contain a sealed refrigerant circuit including a hermetic motor-compressor, bidirectional thermostatic expansion valve, finned tube air-to-refrigerant heat exchanger, reversing valve, coaxial tube water-to-refrigerant heat exchanger, optional hot water generator coil, and service ports.

Compressors shall be high-efficiency single speed rotary or scroll type designed for heat pump duty and mounted on vibration isolators. The compressor shall be double isolation mounted using selected durometer grommets to provide vibration free compressor mounting. Compressor motors shall be single-phase PSC with overload protection.

The air coil shall be sized for low-face velocity and constructed of lanced aluminum fins bonded to rifled aluminum tubes in a staggered pattern not less than three rows deep for enhanced performance.

Option: AlumiSeal electro-coated air coil

The coaxial water-to-refrigerant heat exchanger shall be designed for low water pressure drop and constructed of a convoluted copper (cupronickel option) inner tube and a steel outer tube. Refrigerant to air heat exchangers shall utilize enhanced corrugated lanced aluminum fins and rifled copper tube construction rated to withstand 600 psig (4135 kPa) refrigerant working pressure. Refrigerant to water heat exchangers shall be of copper inner water tube and steel refrigerant outer tube design, rated to withstand 600 psig (4135 kPa) working refrigerant pressure and 450 psig (3101 kPa) working water pressure. The thermostatic expansion valve shall provide proper superheat over the entire liquid temperature range with minimal "hunting." The valve shall operate bidirectionally without the use of check valves.

Option: Cupronickel refrigerant to water heat exchanger shall be of copper-nickel inner water tube and steel refrigerant outer tube design, rated to withstand 600 psig (4135 kPa) working refrigerant pressure and 450 psig (3101 kPa) working water pressure. Water lines shall also be of cupronickel construction.

Option: Hot water generator - Internal double wall vented hot water generator coil refrigerant to water heat exchangers shall be of copper inner water tube and steel refrigerant outer tube design, rated to withstand 600 psig (4135 kPa) working refrigerant pressure and 450 psig (3101 kPa) working water pressure.

Option: ThermaShield coated water-to-refrigerant heat exchanger, water lines and refrigerant suction lines shall be insulated to prevent condensation at low liquid temperatures below 50°F.

Option: AlpinePure hot gas bypass

Engineering Guide Specifications cont.

The hot gas bypass (HGB) option is designed to limit the minimum evaporating pressure in the cooling mode to prevent the air coil from icing. The option shall consist of a hot gas bypass valve installed in the discharge side of the compressor. The refrigerant control shall proportionately bypass hot gas refrigerant to the air coil when suction pressure falls below 115 psig thus limiting air coil freeze-up.

Optional AlpinePure hot gas reheat

An optional hot gas reheat coil shall be available to allow dehumidification-only operation. The internal reheat system shall be factory installed and include a high efficiency reheat coil located downstream of the evaporator coil, a reclaim valve and integral controls to allow heating, cooling and reheat/dehumidification modes. The reheat coil shall be sized so that during reheat/dehumidification mode the unit will produce neutral air (78 ±3°F DB @ 50-58% relative humidity) with typical 80 DB/67 WB °F entering air and 90°F entering water temperature. The reheat coil shall be sized to restrict airflow by no more than 0.17 in wg at 350 feet per minute airflow velocity.

The following control options are available:

Room wall dehumidistat – An optional room wall dehumidistat shall control the reheat mode thru a 24VAC 'Hum' input (On or Off). Setpoint and deadband shall be determined by the dehumidistat.

Dehumidification set point (used only with a humidity sensor) - The factory default set point for dehumidification is 52% this is field adjustable from 30% to 60%. In addition there shall be a factory default differential of 5% field adjustable from 5% to 15%. The control will enable re-heat when the space humidity rises above the set point plus the differential.

Reheat operation during periods of vacancy - The control logic contains an unoccupied set point that can be used for periods the unoccupied mode if desired. The factory default for the set point is 60% and is adjustable from 30% to 60%. The unoccupied setback must be enabled either through a building automation system or with a user interface. Factory default for unoccupied setback is off.

Space humidity high and low alarm limits (building automation system only) - The control has a high and low alarm limit that can be enumerated over a building automation system. The factory default set point for these alarm limits is 0% for the low alarm and 100% for the high alarm limit. These limits can be adjusted through a building automation system.

Blower Motor and Assembly

The blower shall be a direct drive centrifugal type with a dynamically balanced wheel. The housing and wheel shall be designed for quiet low outlet velocity operation. The blower housing shall be removable from the unit without disconnecting the supply air ductwork for servicing of the blower motor. The blower motor shall be isolated from the housing by rubber grommets. The motor shall be permanently lubricated and have thermostatic overload protection.

Option: PSC blower motor shall be a three-speed PSC type.

Option: 5-Speed ECM blower motor shall be a 5-speed ECM

type. The 5-speed ECM blower motor shall be soft starting, shall maintain constant torque over its operating static range, and shall provide 5 speed settings. The blower motor shall be isolated from the housing by rubber grommets. The motor shall be permanently lubricated and have thermostatic overload protection. 5-speed ECM motors shall be long-life ball bearing type.

Option: Variable speed ECM blower motor shall be a variable speed ECM type. The variable speed ECM blower motor shall be soft starting, shall maintain constant cfm over its operating static range, and shall provide 12 cfm settings. Variable speed ECM motors shall be long-life ball bearing type.

Option: High static blower motors shall be available on certain PSC and ECM models.

Electrical

A control box shall be located within the unit compressor compartment and shall contain a 75VA transformer, 24 volt activated, 2 pole compressor contactor, terminal block for thermostat wiring and solid-state controller for complete unit operation. Electromechanical operation WILL NOT be accepted. Units shall be name-plated for use with time delay fuses or HACR circuit breakers. Unit controls shall be 24 volt and provide heating or cooling as required by the remote thermostat/sensor.

An Aurora microprocessor-based controller that interfaces with a multi-stage electronic thermostat to monitor and control unit operation shall be provided. The control shall provide operational sequencing, blower speed control, high and low pressure switch monitoring, freeze detection, condensate overflow sensing, lockout mode control, LED status and fault indicators, fault memory, field selectable options and accessory output. The control shall provide fault retry three times before locking out to limit nuisance trips.

A detachable terminal block with screw terminals will be provided for field control wiring. All units shall have knockouts for entrance of low and line voltage wiring. The blower motor and control box shall be harness plug wired for easy removal.

Optional IntelliStart® (compressor soft starter) shall be factory installed for use in applications that require low starting amps, reduced compressor startup noise, off-grid, and improved startup behavior. IntelliStart shall reduce normal starting current by 60% on 208-230/60/1 units.

Piping

Supply and return water connections shall be FPT copper fittings fixed to the corner post, which eliminate the need for backup pipe wrenches.

With vertical units, the condensate connection shall be a 3/4 in. [19.1 mm] PVC socket with internally-trapped hose that can be routed to front or side corner post locations.

Engineering Guide Specifications cont.

Hanger Kit

(included with horizontal units only - field installed)

The hanger kit shall consist of galvanized steel brackets, bolts, lock washers, and isolators and shall be designed to fasten to the unit bottom panel for suspension from 3/8 in. threaded rods. Unit sizes 009-070 shall include four brackets. Brackets shall not inhibit filter removal in any way.

Accessories

Thermostat (field-installed)

A multi-stage auto-changeover electronic digital thermostat shall be provided. The thermostat shall offer two heating stages and one cooling stage with precise temperature control. An OFF-HEAT-AUTO-COOL-EMERG system switch, OFF-AUTO blower switch, and indicating LEDs shall be provided. The thermostat shall display in °F or °C.

Hose Kits – Ball Valves (field-installed)

A flexible steel braid hose featuring Kevlar® reinforced EPDM core with ANSI 302/304 stainless steel outer braid and fire rated materials per ASTM E 84-00 (NFPA 255, ANSI/UL 723 & UBC 8-1). Ball valve at one end; swivel connector with adapter at the other end (swivel to adapter connection via fiber or EPDM gasket). Swivel connection provides union between heat pump and piping system. The hoses feature brass fittings, stainless steel ferrules. A full port ball valve shall be provided with integral P/T (pressure/temperature) port on supply hose.

Specifications:

- Temperature range of 35°F [2°C] to 180°F [82°C].
- Max. working pressure of 400 psi [2757 kPa] for 1/2 in. and 3/4 in. hose kits; max. working pressure of 350 psi [kPa] for 1 in. and 1-1/4 in. hose kits.

Hose Kits – Automatic Balancing and Ball Valves (field-installed)

A flexible steel braid hose featuring Kevlar® reinforced EPDM core with ANSI 302/304 stainless steel outer braid and fire rated materials per ASTM E 84-00 (NFPA 255, ANSI/UL 723 & UBC 8-1). Ball valve at one end; swivel connector with adapter at the other end (swivel to adapter connection via fiber or EPDM gasket). Swivel connection provides union between heat pump and piping system. The hoses feature brass fittings, stainless steel ferrules. A full port ball valve shall be provided with integral P/T (pressure/temperature) port on supply hose and automatic balancing valve with integral P/T ports and full port ball valve on return hose.

Specifications:

- Temperature range of 35°F [2°C] to 180°F [82°C]
- Max. working pressure of 400 psi [2757 kPa] for 1/2 in. and 3/4 in. hose kits; max. working pressure of 350 psi [2413 kPa] for 1 in. and 1-1/4 in. hose kits
- Minimum burst pressure of four times working pressure

Hose Kits – Automatic Balancing and Ball Valves with ‘Y’ strainer (field-installed)

A flexible steel braid hose featuring Kevlar® reinforced EPDM core with ANSI 302/304 stainless steel outer braid and fire rated materials per ASTM E 84-00 (NFPA 255, ANSI/UL 723 & UBC 8-1). Ball valve at one end; swivel connector with adapter at the other end (swivel to adapter connection via fiber or EPDM gasket). Swivel connection provides union between heat pump and piping system. The hoses feature brass fittings, stainless steel ferrules. A “y” strainer is provided on one end for fluid straining and integral “blowdown” valve. A full port ball valve shall be provided with integral P/T (pressure/temperature) port on supply hose and automatic balancing valve with integral P/T ports and full port ball valve on return hose.

Specifications:

- Temperature range of 35°F [2°C] to 180°F [82°C]
- Max. working pressure of 400 psi [2756 kPa] for 1/2 in. and 3/4 in. hose kits; max. working pressure of 350 psi [2413 kPa] for 1 in. and 1-1/4 in. hose kits
- Minimum burst pressure of four times working pressure

Hot Water Pump Kit

An accessory pump kit is available for hot water generation option. This kit includes hot water pump, fittings, and water heater kit necessary for potable water application. Order DPK5 for use with Aurora and FX10 controls.

Revision Guide

Pages:	Description:	Date:	By:
Misc.	Updated wiring schematics	30 Nov 2018	MA
Misc.	Updated Nomenclature, wiring schematics, AHRI Data	27 May 2016	MA
2, 47	Updated Pressure Drop Data, Updated ETL Logo	19 May 2015	MA
All	First Published	18 Oct 2013	DS



Product: **LX Ultra Series**
Type: Geothermal/Water Source Heat Pumps
Size: 0.75-6 Ton

Document Type: Specification Catalog
Part Number: SC1200AK6
Release Date: 11/18