



Heating and Air Conditioning

***SPECIFICATION CATALOG***

**AFFINITY LARGE**

**COMMERCIAL GEOTHERMAL/  
WATER SOURCE HEAT PUMPS  
SINGLE AND DUAL CAPACITY**

**MODELS:**

**HORIZONTAL: YL080 - 120  
(7 THRU 10 NOMINAL TONS)**

**VERTICAL: YL080 - 300  
(7 THRU 25 NOMINAL TONS)**



Due to continuous product improvement, specifications are subject to change without notice.

Visit us on the web at [www.yorkgeothermal.com](http://www.yorkgeothermal.com)

Additional rating information can found at  
[www.ahrirectory.org](http://www.ahrirectory.org)

FOR DISTRIBUTION USE ONLY - NOT TO BE USED AT POINT OF RETAIL SALE



## Table of Contents

---

Model Nomenclature .....	4
AHRI Data .....	5-6
The Affinity Large Series .....	7-10
Inside the Affinity Large Series .....	11-12
Affinity Large Series Controls .....	13-18
Affinity Large Series Application Notes .....	19-21
Water Quality .....	21
Installation Notes .....	22-25
Vertical Dimensional Data .....	26-27
Horizontal Dimensional Data .....	28
Hanger Bracket Locations .....	29
Physical Data .....	29
Electrical Data .....	30
Blower Performance Data .....	31-40
Selection Example .....	41-42
Antifreeze Correction .....	43
Reference Calculations .....	44
Legend and Notes .....	44
Correction Factor Tables .....	45
Operating Limits .....	46
Pressure Drop .....	46
Performance Data .....	47-56
Wiring Schematics .....	57-58
Engineering Guide Specifications .....	59-61
Revision Guide .....	62

# Model Nomenclature

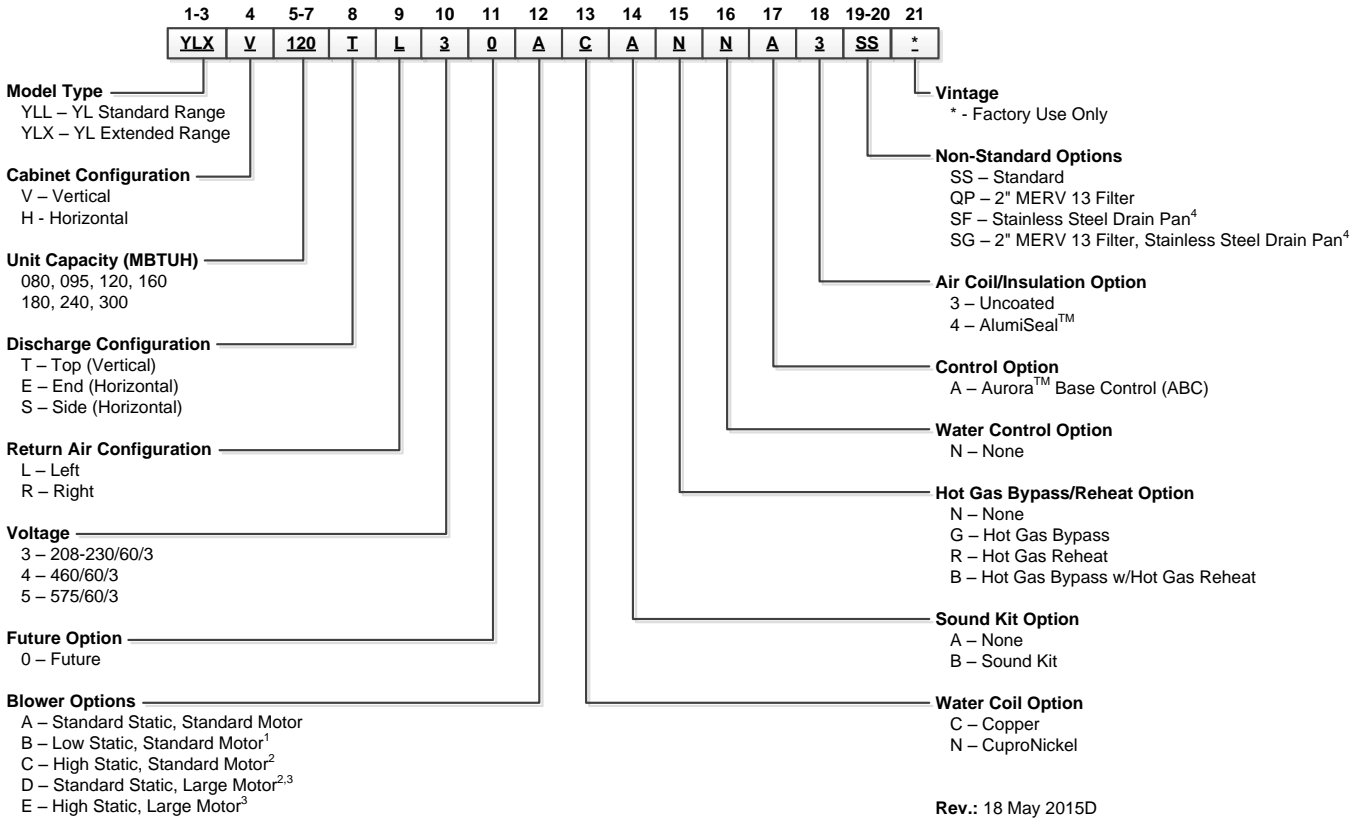

**Notes:**

- 1 – Not available on YLXV/YLLV095, 180, YLXH/YLLH080
- 2 – Not available on YLXV/YLLV080, 160
- 3 – Not available on YLXH/YLLH120, YLXV/YLLV300
- 4 – Not available on YLXV/YLLV160-300. Stainless steel is standard on YLXV/YLLV160-300



All Affinity Large Series product is Safety listed under UL1995 thru ETL and performance listed with AHRI in accordance with standard 13256-1.

## AHRI Data

### English (IP) Units

Model		Flow Rate		Water Loop Heat Pump				Ground Water Heat Pump				Ground Loop Heat Pump			
				Cooling EWT 86°F		Heating EWT 68°F		Cooling EWT 59°F		Heating EWT 50°F		Cooling EWT 77°F		Heating EWT 32°F	
		gpm	cfm	Capacity Btuh	EER Btuh/W	Capacity Btuh	COP	Capacity Btuh	EER Btuh/W	Capacity Btuh	COP	Capacity Btuh	EER Btuh/W	Capacity Btuh	COP
Horizontal	YL080	22.0	2600	73,000	15.5	77,700	4.7	79,000	22.5	65,800	4.2	76,000	17.7	51,300	3.5
	YL095	24.0	3200	85,500	15.6	91,000	4.8	95,000	23.0	78,000	4.3	91,200	18.1	61,600	3.5
	YL120	28.0	3600	113,000	13.8	140,600	4.6	129,000	21.9	115,000	4.1	119,500	16.2	89,000	3.4
Vertical	YL080	22.0	2600	76,000	16.5	85,000	5.0	84,000	24.2	71,000	4.4	83,000	19.7	55,000	3.7
	YL095	24.0	2800	91,000	17.2	100,000	5.2	101,000	25.7	83,000	4.6	95,000	19.6	65,000	3.8
	YL120	28.0	3600	115,000	15.5	136,000	5.1	135,000	24.3	107,500	4.4	122,000	18.0	83,000	3.6
	YL160*	35.0	5000	166,000	18.9	154,000	5.1	178,000	25.3	130,000	4.6	171,000	21.0	97,000	3.7
	YL180*	45.0	5600	180,000	17.1	190,000	5.0	187,000	22.2	149,000	4.3	185,000	18.5	109,000	3.4
	YL240*	60.0	7600	240,000	16.3	296,000	5.2	264,000	22.5	237,000	4.6	246,000	17.4	184,000	3.8
	YL300*	75.0	9500	284,000	17.3	353,000	5.4	314,000	24.5	286,000	4.8	291,000	19.0	224,000	4.2

Cooling capacities based upon 80.6°F DB, 66.2°F WB entering air temperature

Heating capacities based upon 68°F DB, 59°F WB entering air temperature

All ratings based upon 208V operation.

\* Ratings for models YL160-300 are outside the scope of the AHRI Water to Air/Brine to Air Heat Pumps Certification Program.

12/9/08

## AHRI Data cont.

The performance standard AHRI/ASHRAE/ISO 13256-1 became effective January 1, 2000 and replaces ARI Standards 320, 325, and 330. This new standard has three major categories: Water Loop (comparable to ARI 320), Ground Water (ARI 325), and Ground Loop (ARI 330). Although these standards are similar there are some differences:

### Unit of Measure: The Cooling COP

The cooling efficiency is measured in EER (US version measured in Btuh per Watt. The Metric version is measured in a cooling COP (Watt per Watt) similar to the traditional COP measurement.

### Water Conditions Differences

Entering water temperatures have changed to reflect the centigrade temperature scale. For instance the water loop heating test is performed with 68°F (20°C) water rounded down from the old 70°F (21.1°C).

### Air Conditions Differences

Entering air temperatures have also changed (rounded down) to reflect the centigrade temperature scale. For instance the cooling tests are performed with 80.6°F (27°C) dry bulb and 66.2°F (19°C) wet bulb entering air instead of the traditional 80°F (26.7°C) DB and 67°F (19.4°C) WB entering air temperatures. 80.6/66.2 data may be converted to 80/67 using the entering air correction table. This represents a significantly lower relative humidity than the old 80/67 of 50% and will result in lower latent capacities.

### Pump Power Correction Calculation

Within each model, only one water flow rate is specified for all three groups and pumping Watts are calculated using the following formula. This additional power is added onto the existing power consumption.

- Pump power correction = (gpm x 0.0631) x (Press Drop x 2990) / 300

Where 'gpm' is waterflow in gpm and 'Press Drop' is the pressure drop through the unit heat exchanger at rated water flow in feet of head.

### Blower Power Correction Calculation

Blower power is corrected to zero external static pressure using the following equation. The nominal airflow is rated at a specific external static pressure. This effectively reduces the power consumption of the unit and increases cooling capacity but decreases heating capacity. These Watts are significant enough in most cases to increase EER and COPs fairly dramatically over ARI 320, 325, and 330 ratings.

- Blower Power Correction = (cfm x 0.472) x (esp x 249) / 300

Where 'cfm' is airflow in cfm and 'esp' is the external static pressure at rated airflow in inches of water gauge.

### ISO Capacity and Efficiency Calculations

The following equations illustrate cooling calculations:

- ISO Cooling Capacity = Cooling Capacity (Btuh) + (Blower Power Correction (Watts) x 3.412)
- ISO EER Efficiency (W/W) = ISO Cooling Capacity (Btuh) x 3.412 / [Power Input (Watts) - Blower Power Correction (Watts) + Pump Power Correction (Watt)]

The following equations illustrate heating calculations:

- ISO Heating Capacity = Heating Capacity (Btuh) - (Blower Power Correction (Watts) x 3.412)
- ISO COP Efficiency (W/W) = ISO Heating Capacity (Btuh) x 3.412 / [Power Input (Watts) - Blower Power Correction (Watts) + Pump Power Correction (Watt)]

### Comparison of Test Conditions

	ARI 320	ISO/AHRI 13256-1 WLHP	ARI 325	ISO/AHRI 13256-1 GWHP	ARI 330	ISO/AHRI 13256-1 GLHP
<b>Cooling</b>						
Entering Air - DB/WB °F	80/67	80.6/66.2	80/67	80.6/66.2	80/67	80.6/66.2
Entering Water - °F	85	86	50/70	59	77	77
Fluid Flow Rate	*	**	**	**	**	**
<b>Heating</b>						
Entering Air - DB/WB °F	70	68	70	68	70	68
Entering Water - °F	70	68	50/70	50	32	32
Fluid Flow Rate	*	**	**	**	**	**

Note \*: Flow rate is set by 10°F rise in standard cooling test  
Part load entering water conditions not shown.

Note \*\*: Flow rate is specified by the manufacturer

WLHP = Water Loop Heat Pump; GWHP = Ground Water Heat Pump; GLHP = Ground Loop Heat Pump

### Conversions:

Airflow (lps) = CFM x 0.472;

WaterFlow (lps) = GPM x 0.0631;

ESP (Pascals) = ESP (in wg) x 249;

Press Drop (Pascals) = Press Drop (ft hd) x 2990

# The Affinity Large Series

## Product Features: Vertical Cabinet

Affinity Large Series Vertical units are designed for high efficiency, maximum flexibility and primary servicing from the front and side.

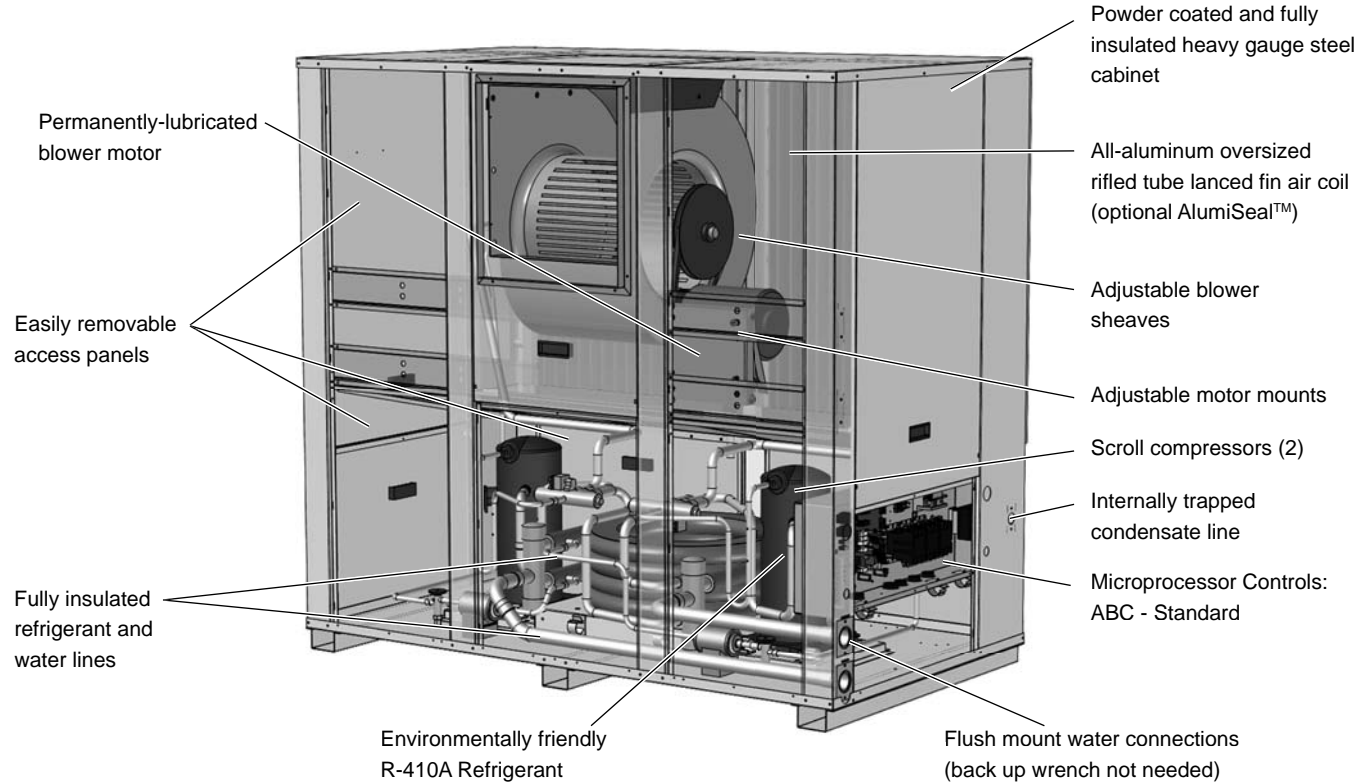

A true left and right return option is available.

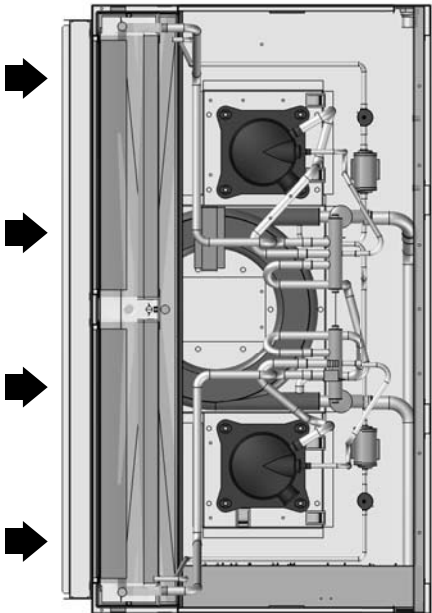

Left hand return

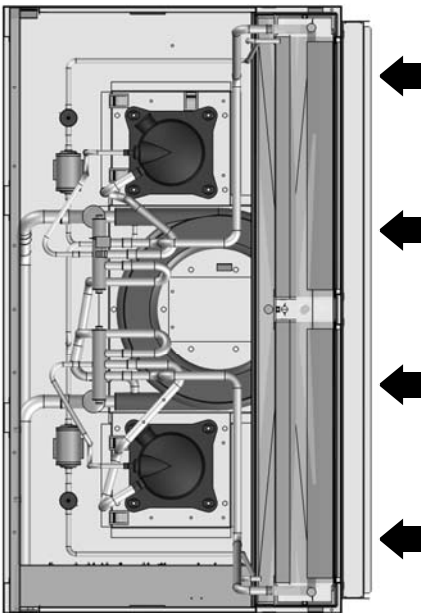

Right hand return

## The Affinity Large Series cont.

### Product Features: Horizontal Cabinet

The Affinity Large Series Horizontal units provide high efficiency, maximum flexibility, and primary servicing from the front. These units are available in one cabinet size.

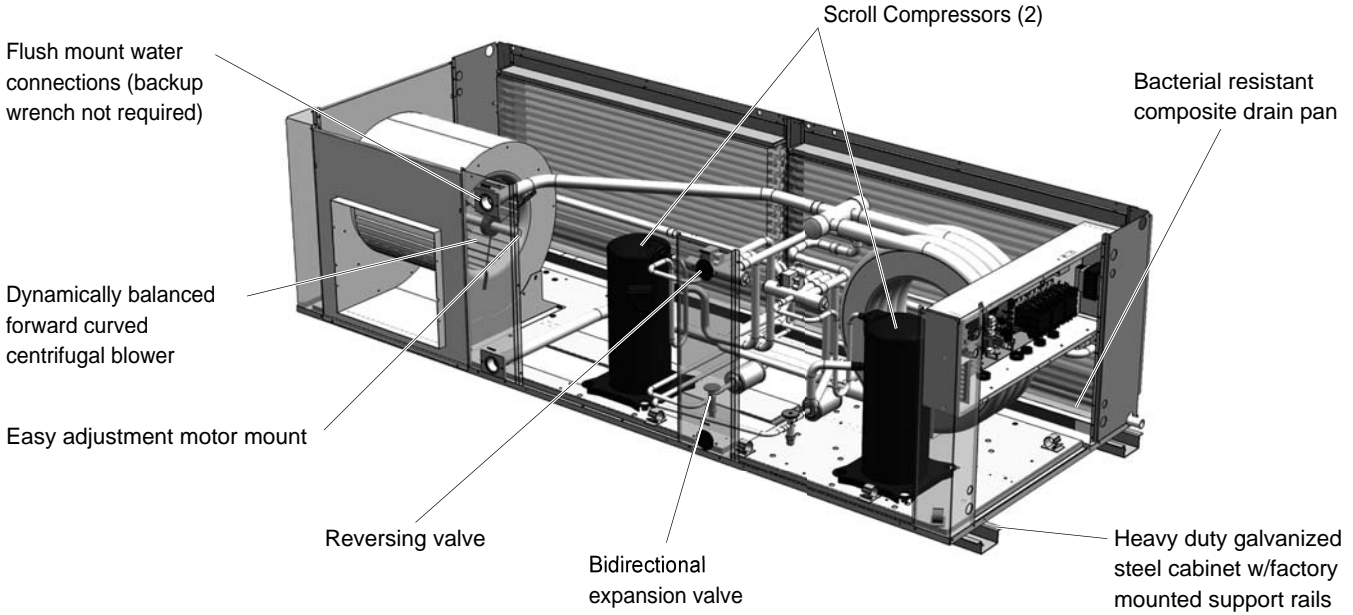

Four blower deck options are available. Factory or field conversion option of end or side discharge using switchable access panels and a factory only option of true left or right return air coil.

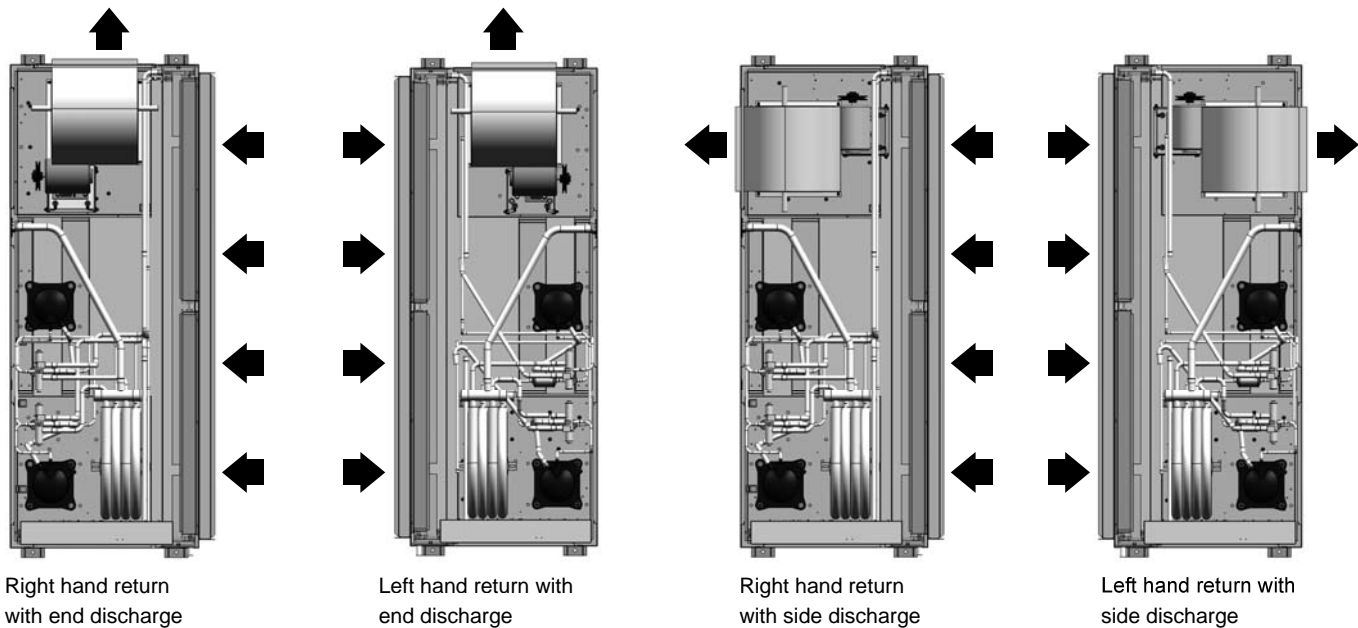



## The Affinity Large Series cont.

### High Efficiency

Affinity Large Series is the highest efficiency units available. Large oversized air coils, water to refrigerant heat exchangers and scroll compressors provide extremely efficient operation. This efficiency means the Affinity Large Series requires less loop than any product on the market. This can mean significant savings on commercial projects.

### Quiet Operation

All Affinity Large Series product is AHRI 260 sound rated using third party sound testing. Room Noise Criteria Curves (NC Curve) may be calculated using data from the AHRI 260 ratings giving the engineer total flexibility in assuring a quiet environment.

### Standard Features

- Large low rpm blower.
- Heavy gauge cabinet and rails on horizontals to hang for vibration isolation.
- Quiet scroll compressors in all models
- 2-dimension refrigerant piping vibration loops to isolate the compressor.
- All interior cabinet surfaces including the compressor compartment are insulated with 1/2 in. [12.7 mm] thick 1-1/2 lb. [681 g] density, surface coated, acoustic type glass fiber insulation.

### Super Quiet Option

An optional SuperQuiet Sound Package is also available for a modest cost and features multi-density laminate lined compressor blanket designed to completely surround the compressor and suppress low frequency noise.



### AlpinePure™ Indoor Air Quality (IAQ)

The Affinity Large Series features several IAQ benefits. All units feature:

- Corrosion-free plastic or stainless steel double-sloped drain pan to eliminate standing water and prevent bacterial growth.
- Foil-faced fiber insulation in all air handler compartments to allow cleanability and inhibit bacteria growth. Optional non-fibrous closed cell insulation is also available for more sensitive applications.
- An optional low static high efficiency 2 in. [5.1 cm] MERV 13 filter is also available.



### Easy Maintenance and Service Advantages

- Removable compressor access panels.
- Separate Air handler and compressor section access panels permit service testing without bypass (Vertical only).
- Removable low voltage connector for easy thermostat wiring.
- Quick attach wiring harnesses are used throughout for fast servicing.
- High and low pressure refrigerant service ports.
- Internal drop out blowers (vertical) and access panel view of all blower motors (horizontal).

### Secondary Drain Option (Special)

Some local building authority's interpretation of codes require more condensate overflow protection than standard microprocessor based condensate sensors offer. In these areas a full secondary drain pan might be required causing both increased cost and unit service access issues. In many of these cases a secondary drain option can be added to the unit to pass this local interpretation of condensate drain redundancy. This option adds a second PVC drain connection to the drain pan at a higher level. This can be ordered as a special and is only available in plastic.



### Factory Quality

- All refrigerant brazing is performed in a nitrogen environment.
- Computer controlled deep vacuum and refrigerant charging system.
- All joints are leak detected for maximum leak rate of less than 1/4 oz. per year.
- Computer bar code equipped assembly line insures all components are correct.
- All units are computer run-tested with water to verify both function and performance.

## Inside the Affinity Large Series

### Refrigerant

Affinity Large Series products all feature zero ozone depletion and low global warming potential R-410A refrigerant.

### Cabinet

All vertical units are all constructed of corrosion resistant galvanized sheet metal with optional white polyester powder coat paint rated for more than 1000 hours of salt spray. Large lift-out access panels provide access to the compressor section from four sides. Refrigerant circuit is designed to allow primary serviceability from the front. 1 horizontal and 2 vertical cabinets are provided for application flexibility. Air handler access panels allow servicing of the blower motor, blower, and drain pan. The blower motor and blower can be completely serviced or replaced without removal of the unit. Side or top discharge option is available on vertical units

Flexible configurations include 4 blower deck options for horizontals and a true left and right return on both horizontal and vertical.

### Filter Rack

A 2 in. [5.1 cm] disposable filter is standard. An optional 2 in. MERV 13 for high efficiency filtration is available.



### Compressors

High efficiency R410A scroll compressors are used on every model. Scrolls provide both the highest efficiency available and great reliability.

### Electrical Box

Unit controls feature quick connect wiring harnesses for easy servicing. Separate knockouts for LV, and two for power on two sides allow easy access to the control box. Large 75VA transformer assures adequate controls power for accessories.



### Water Connections

Flush mount FPT water connection fittings allow one wrench leak-free connections and do not require a backup wrench.



### Drain Pan

Bacteria resistant composite drain pan is sloped to promote complete drainage and will never rust or corrode. Complete drainage helps to inhibit bacterial or microbial growth. Vertical units feature an internally trapped condensate line using clear pvc hose for easy inspection and reduced installation cost. Stainless steel drain pans are available for 7-25 ton units.



### Thermostatic Expansion Valve

All Affinity Large Series models utilize a balanced port bi-directional thermostatic expansion valve (TXV) for refrigerant metering. This allows precise refrigerant flow in a wide range of entering water variation (20 to 120°F [-7 to 49°C]) found in geothermal systems. The TXV is located in the compressor compartment for easy access.



## Inside the Affinity Large Series cont.

### Water to Refrigerant Coaxial Heat Exchanger Coil

Large oversized coaxial refrigerant to water heat exchangers provide unparalleled efficiency. The coaxes are designed for low pressure drop and low flow rates. All coaxes are pressure rated to 450 psi water side and 600 psi on the refrigerant side. Optional refrigerant and coaxial heat exchanger insulation is available to prevent condensation in low temperature loop operation.



### Service Connections and Serviceability

Two Schrader service ports are provided for each circuit on every unit. The suction side and discharge side ports are for field charging and servicing access. All valves are 7/16 in. SAE connections. All water and electrical connections are made from the front of the unit. Unit is designed for front access serviceability.



### Blower Motor and Housing

High efficiency low rpm galvanized belt drive blower – reducing air noise. High static options are available in most models. Horizontal units can be field converted from end to side discharge. Vertical units can be field converted from top to side discharge with a few additional parts.

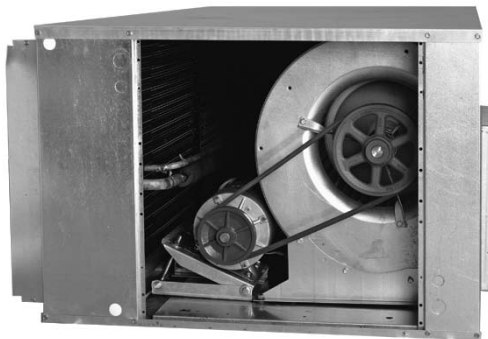

### Adjustable Motor Mount

A heavy duty, 16 ga. steel adjustment motor mount is provided to allow easy service of the belt, sheaves, and blower motor. The angle of the plate can be easily adjusted in the field without removal of the blower motor. This prevents the need for the

service technician to realign the blower motor after service has been completed.

### Air Coil

All-aluminum round-tube-and-fin air coil in a packaged water source heat pump. These air coils are constructed of lanced fin and rifled tube aluminum that is not susceptible to formicary corrosion. For additional condensate runoff and meeting project specifications, an optional AlumiSeal e-coating is available.



### 4-Way Reversing Valve

Affinity Large Series units feature a reliable all-brass pilot operated refrigerant reversing valve. The reversing valve operation is limited to change of mode by the control to enhance reliability.



### Air Handler Insulation

Foil Faced air handler insulation provides cleanability to further enhance IAQ.



# Affinity Large Series Controls - Aurora Base Controls

## Aurora 'Base' Control

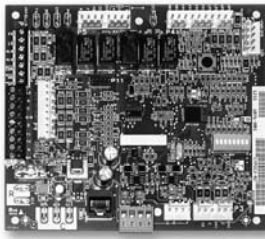

**NOTE:** Refer to the Aurora Base Control Application and Troubleshooting Guide and the Instruction Guide: Aurora Interface and Diagnostics (AID) Tool for additional information.

## Control Features

Software ABC Standard Version 2.0

### Single or Dual Capacity Compressors

Either single or dual capacity compressors can be operated.

### Variable Speed ECM

#### Blower Motor Option (If Applicable)

A Variable Speed ECM blower motor can be driven directly using the onboard PWM output. Four blower speeds are available based upon the G, Y1, Y2, and W input signals to the board. The blower speeds can be changed either by the ECM manual configurations mode method or by using the Aurora AID Tool directly. All four blower speeds can be set to the same speed if desired.

#### 5-Speed ECM Blower Motor Option (If Applicable)

A 5-Speed ECM blower motor will be driven directly using the thermostat connections. Any of the G, Y1, or Y2/W signals can drive any of the 5 available pre-programmed blower speeds on the motor. All 5 Series "G" vintage units will be wired this way at the factory.

## Other Control Features

- Random start at power up
- Anti-short cycle protection
- High and low pressure cutouts
- Loss of charge
- Water coil freeze detection
- Air coil freeze detection
- Over/under voltage protection
- Condensate overflow sensor
- Load shed
- Dehumidification (where applicable)
- Emergency shutdown
- Hot gas reheat operation (where applicable)
- Diagnostic LED
- Test mode push button switch
- Two auxiliary electric heat outputs
- Alarm output
- Accessory output with N.O. and N.C.
- Modbus communication (master)
- Modbus communication (slave)

## Field Selectable Options via Hardware

**DIP Switch (SW1)** – Test/Configuration Button (See SW1 Operation Table)

### Test Mode

The control is placed in the test mode by holding the push button switch SW1 for 2 - 5 seconds. In test mode most of the control timings will be shortened by a factor of sixteen (16). LED3 (green) will flash at 1 second on and 1 second off. Additionally, when entering test mode LED1 (red) will flash the last lockout one time. Test mode will automatically time out after 30 minutes. Test mode can be exited by pressing and holding the SW1 button for 2 to 5 seconds or by cycling the power. **NOTE:** Test mode will automatically be exited after 30 minutes.

### ECM Configuration Mode (If Applicable)

The control is placed in the ECM configuration mode by holding the pushbutton switch SW1 for 5 to 10 seconds, the high, low, and "G" ECM speeds can be selected by following the LED display lights. LED2 (yellow) will fast flash when entering the ECM configuration. When setting "G" speed LED3 (green) will be continuously lit, for low speed LED1 (red) will be continuously lit, and for high speed both LED3 (green) and LED1 (red) will be continuously lit. During the ECM configuration mode LED2 (yellow) will flash each of the 12 possible blower speeds 3 times. When the desired speed is flashed press SW1, LED2 will fast flash until SW1 is released. "G" speed has now been selected. Next select low speed, and high speed blower selections following the same process above. After third selection has been made, the control will exit the ECM configuration mode. Aux fan speed will remain at default or current setting and requires the AID Tool for adjustment.

### Reset Configuration Mode

The control is placed in reset configuration mode by holding the push button switch SW1 for 50 to 60 seconds. This will reset all configuration settings and the EEPROM back to the factory default settings. LED3 (green) will turn off when entering reset configuration mode. Once LED3 (green) turns off, release SW1 and the control will reset.

### DIP Switch (SW2)

**SW2-1** FP1 Selection – Low water coil temperature limit setting for freeze detection. On = 30°F; Off = 15°F.

**SW2-2** FP2 Selection – On = 30°F; Off = N/A

**SW2-3** RV – O/B - thermostat type. Heat pump thermostats with "O" output in cooling or "B" output in Heating can be selected. On = O; Off = B.

**SW2-4** Access Relay Operation (P2)  
**and 2-5**

Access Relay Operation	SW2-4	SW2-5
Cycle with Blower	ON	ON
Cycle with Compressor	OFF	OFF
Water Valve Slow Opening	ON	OFF
Cycle with Comm. T-stat Hum Cmd	OFF	ON

## Affinity Large Series Controls - Aurora Base Controls cont.

**Cycle with Blower** - The accessory relay will cycle with the blower output.

**Cycle with Compressor** - The accessory relay will cycle with the compressor output.

**Water Valve Slow Opening** - The accessory relay will cycle and delay both the blower and compressor output for 90 seconds.

- SW2-6** CC Operation – selection of single or dual capacity compressor. On = Single Stage; Off = Dual Capacity
- SW2-7** Lockout and Alarm Outputs (P2) – selection of a continuous or pulsed output for both the LO and ALM Outputs. On = Continuous; Off = Pulsed
- SW2-8** Future Use

### Alarm Jumper Clip Selection

From the factory, ALM is connected to 24 VAC via JW2. By cutting JW2, ALM becomes a dry contact connected to ALG.

### ECM Blower Speeds

The blower speeds can be changed either by using the ECM manual configurations mode method or by using the Aurora AID Tool directly (see Instruction Guide: Aurora Interface and Diagnostics (AID) Tool topic).

### Field Selectable Options via Software

(Selectable via the Aurora AID Tool)

#### ECM Blower Speeds

An ECM blower motor can be driven directly using the onboard PWM output. Four blower speeds are available, based upon the “G”, Y1 (low), Y2 (high), and Aux input signals to the board. The blower speeds can be changed either by the ECM manual configurations mode method (see ECM Configuration Mode topic) or by using the Aurora AID Tool directly. All four blower speeds can be set to the same speed if desired. Aux blower speed will remain at default or current setting and requires the AID Tool for adjustment.

### Safety Features

The following safety features are provided to protect the compressor, heat exchangers, wiring and other components from damage caused by operation outside of design conditions.

**Fuse** – a 3 amp automotive type plug-in fuse provides protection against short circuit or overload conditions.

**Anti-Short Cycle Protection** – 4 minute anti-short cycle protection for the compressor.

**Random Start** – 5 to 80 second random start upon power up.

**Fault Retry** – in the fault condition, the control will stage off the outputs and then “try again” to satisfy the thermostat Y input call. Once the thermostat input calls are satisfied, the control will continue on as if no fault occurred. If 3 consecutive faults occur without satisfying the thermostat Y input call, then the control will go to Lockout mode.

**Lockout** – when locked out, the blower will operate continuously in “G” speed, and PSC blower motor output will remain on. The Alarm

output (ALM) and Lockout output (L) will be turned on. The fault type identification display LED1 (Red) shall flash the fault code. To reset lockout conditions with SW2-8 On, thermostat inputs “Y1”, “Y2”, and “W” must be removed for at least 3 seconds. To reset lockout conditions with SW2-8 Off, thermostat inputs “Y1”, “Y2”, “W”, and “DH” must be removed for at least 3 seconds. Lockout may also be reset by turning power off for at least 30 seconds or by enabling the emergency shutdown input for at least 3 seconds.

**Lockout With Emergency Heat** - if the control is locked out in the heating mode, and a Y2 or W input is received, the control will operate in the emergency heat mode while the compressor is locked out. The first emergency heat output will be energized 10 seconds after the W input is received, and the blower will shift to high speed. If the control remains locked out, and the W input is present, additional stage of emergency heat will stage on after 2 minutes. When the W input is removed, all of the emergency heat outputs will turn off, and the ECM blower will shift to “G” speed and PSC blower motor output will remain on.

**High Pressure** – fault is recognized when the Normally Closed High Pressure Switch, P4-9/10 opens, no matter how momentarily. The High Pressure Switch is electrically in series with the Compressor Contactor and serves as a hard-wired limit switch if an overpressure condition should occur.

**Low Pressure** - fault is recognized when the Normally Closed Low Pressure Switch, P4-7/8 is continuously open for 30 seconds. Closure of the LPS any time during the 30 second recognition time restarts the 30 second continuous open requirement. A continuously open LPS shall not be recognized during the 2 minute startup bypass time.

**Loss of Charge** – fault is recognized when the Normally Closed Low Pressure Switch, P4-7/8 is open prior to the compressor starting.

**Condensate Overflow** - fault is recognized when the impedance between this line and 24 VAC common or chassis ground drops below 100K ohms for 30 seconds continuously.

**Freeze Detection (Coax)** - set points shall be either 30°F or 15°F. When the thermistor temperature drops below the selected set point, the control shall begin counting down the 30 seconds delay. If the thermistor value rises above the selected set point, then the count should reset. The resistance value must remain below the selected set point for the entire length of the appropriate delay to be recognized as a fault. This fault will be ignored for the initial 2 minutes of the compressor run time.

**Freeze Detection (Air Coil)** - uses the FP2 input to protect against ice formation on the air coil. The FP2 input will operate exactly like FP1 except that the set point is 30 degrees and is not field adjustable.

## Affinity Large Series Controls - Aurora Base Controls cont.

Over/Under Voltage Shutdown - An over/under voltage condition exists when the control voltage is outside the range of 18 VAC to 30 VAC. If the over/under voltage shutdown lasts for 15 minutes, the lockout and alarm relay will be energized. Over/under voltage shutdown is self-resetting in that if the voltage comes back within range of 18 VAC to 30 VAC for at least 0.5 seconds, then normal operation is restored.

### Operation Description

**Power Up** - The unit will not operate until all the inputs and safety controls are checked for normal conditions. The unit has a 5 to 80 second random start delay at power up. Then the compressor has a 4 minute anti-short cycle delay after the random start delay.

**Standby** In standby mode, Y1, Y2, W, DH, and G are not active. Input O may be active. The blower and compressor will be off.

### Heating Operation

#### **Single Compressor Heating, 2nd Stage (Y1, Y2)**

The compressor will be staged to full capacity 20 seconds after Y2 input is received. The ECM blower will shift to high speed seconds after the Y2 input is received.

#### **Dual Compressor Heating, 2nd Stage (Y1, Y2)**

In dual compressor operation, two ABC boards used in 24 VAC operation, there will be a Y2 call to the Y1 input on the second ABC. The compressor will stage to full capacity 30 seconds after Y1 input is received to the second board.

#### **Single Compressor Heating, 3rd Stage (Y1, Y2, W)**

The hot water pump is de-energized and the first stage of electric heat is energized 10 seconds after the W command is received. If the demand continues the second stage of electric heat will be energized after 5 minutes.

#### **Dual Compressor Heating, 3rd Stage (Y1, Y2, W)**

The first stage of electric heat is energized 10 seconds after the W command is received. If the demand continues the second stage of electric heat will be energized after 5 minutes

**Emergency Heat (W)** - The blower will be started on "G" speed, 10 seconds later the first stage of electric heat will be turned on. 5 seconds after the first stage of electric heat is energized the blower will shift to Aux speed. If the emergency heat demand is not satisfied after 2 minutes the second electric heat stage will be energized.

**Blower (G)** - The blower will start immediately upon receiving a thermostat G command. If there are no other commands from the thermostat the ECM will run on "G" speed until the G command is removed. Regardless of blower input (G) from the thermostat, the blower will remain on for 30 seconds at the end of each heating cycle.

### Cooling Operation

In all cooling operations, the reversing valve directly tracks the O input. Thus, anytime the O input is present, the reversing valve will be energized.

#### **Single Compressor Cooling, 2nd Stage (Y1, Y2, O)**

The compressor will be staged to full capacity 20 seconds after Y2 input was received. The ECM blower will shift to high speed 15 seconds after the Y2 input was received.

#### **Dual Compressor Cooling, 2nd Stage (Y1, Y2, O)**

In dual compressor operation, two ABC boards used in 24 VAC operation, there will be a Y2 call to the Y1 input on the second ABC. The compressor will stage to full capacity 30 seconds after Y1 input is received to the second board.

**Blower (G)** - The blower will start immediately upon receiving a thermostat G command. If there are no other commands from the thermostat the ECM will run on "G" speed until the G command is removed. Regardless of blower input (G) from the thermostat, the blower will remain on for 30 seconds at the end of each heating, cooling, and emergency heat cycle.

**Dehumidification (Y1, O, DH or Y1, Y2, O, DH)** - When a DH command is received from the thermostat during a compressor call for cooling the ECM blower speed will be reduced by 15% to increase dehumidification.

**Emergency Shutdown** - Four (4) seconds after a valid ES input, P2-7 is present, all control outputs will be turned off and remain off until the emergency shutdown input is no longer present. The first time that the compressor is started after the control exits the emergency shutdown mode, there will be an anti-short cycle delay followed by a random start delay. Input must be tied to common to activate.

**Continuous Blower Operation** - The blower output will be energized any time the control has a G input present, unless the control has an emergency shutdown input present. The blower output will be turned off when G input is removed.

**Load Shed** - The LS input disables all outputs with the exception of the blower output. When the LS input has been cleared, the anti-short cycle timer and random start timer will be initiated. Input must be tied to common to activate.

# Affinity Large Series Controls - Aurora Base Controls cont.

## Aurora 'Base' Control LED Displays

These three LEDs display the status, configuration, and fault codes for the control. These can also be read in plain English via the Aurora AID Tool.

### Status LED (LED3, Green)

Description of Operation	Fault LED, Green
Normal Mode	ON
Control is Non-functional	OFF
Test Mode	Slow Flash
Lockout Active	Fast Flash
Dehumidification Mode	Flash Code 2
(Future Use)	Flash Code 3
(Future Use)	Flash Code 4
Load Shed	Flash Code 5
ESD	Flash Code 6
(Future Use)	Flash Code 7

### Configuration LED (LED2, Yellow)

Description of Operation	Configuration LED, Yellow
No Software Overwritten	Flashing ECM Setting
DIP Switch was Overwritten	Slow Flash
ECM Configuration Mode	Fast Flash

### Fault LED (LED1, Red)

Red Fault LED	LED Flash Code*	Lockout	Reset/Remove
Normal - No Faults	OFF	-	
Fault - Input	1	No	Auto
Fault - High Pressure	2	Yes	Hard or Soft
Fault - Low Pressure	3	Yes	Hard or Soft
Fault - Freeze Detection FP2	4	Yes	Hard or Soft
Fault - Freeze Detection FP1	5	Yes	Hard or Soft
Fault - Condensate Overflow	7	Yes	Hard or Soft
Fault - Over/Under Voltage	8	No	Auto
Fault - FP1 & FP2 Sensor Error	11	Yes	Hard or Soft

**NOTE:** All codes >11 use long flash for tens digit and short flash for the ones digit. 20, 30, 40, 50, etc. are skipped.

## Aurora Interface and Diagnostics (AID) Tool

The Aurora Interface and Diagnostics (AID) Tool is a device that is a member of the Aurora network. The AID Tool is used to troubleshoot equipment which uses the Aurora control via Modbus RTU communication. The AID Tool provides diagnostics, fault management, ECM setup, and system configuration capabilities to the Aurora family of controls. An AID Tool is recommended, although not required, for ECM airflow settings. The AID Tool simply plugs into the exterior of the cabinet in the AID Tool port.



## ABC Control Board Layout

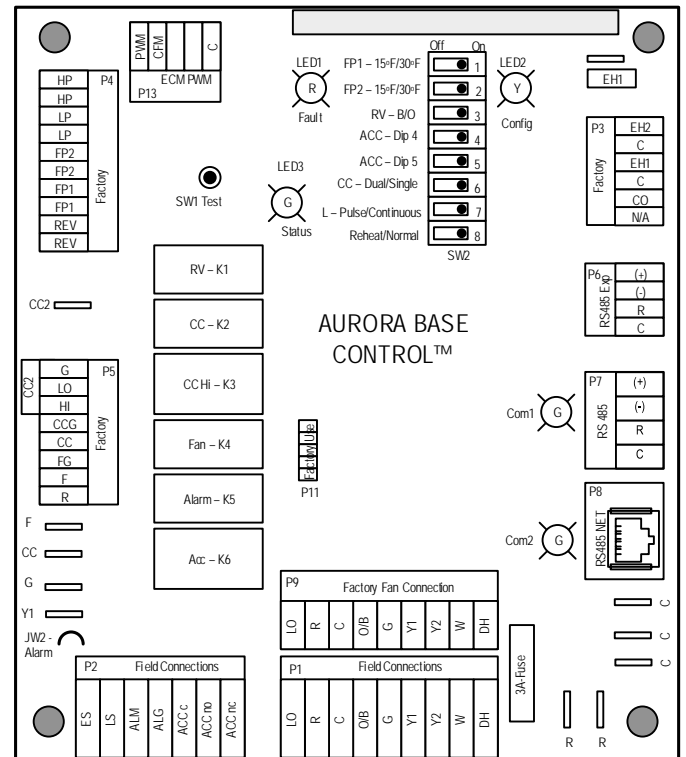

## Hot Gas Reheat/ Hot Gas Bypass

---

### Hot Gas Reheat Description

The refrigerant flows in normal heat pump path in heating and cooling mode. During the Reheat mode, the operation begins with superheated vapor leaving the compressor going through the reheat valve to the reheat air coil. In the reheat coil the high temperature high pressure gas reheats the air exiting the unit to near neutral. Next, the refrigerant exits the reheat coil and passes through a check valve, which is used to prevent refrigerant flow into the reheat coil during normal heating and cooling operation. The refrigerant passes through the check valve and is then diverted to the coaxial heat exchanger by the four way reversing valve. The hot gas enters the coaxial heat exchanger which will condense the gas to a high pressure liquid due to heat being rejected to the loop fluid. The high pressure liquid leaves the coax and enters the inlet of the TXV. After passing through the TXV the low pressure mixture of liquid/vapor refrigerant expands in the air coil evaporating into a low pressure low temperature gas and moves back through the reversing valve and into the compressor suction. The cycle then starts again by compressing the low pressure low temperature gas into a superheated vapor. A small copper bleed line is located on the reheat/reclaim valve to allow refrigerant that has migrated to the reheat coil to escape.

### Hot Gas Bypass Description

The hot gas bypass (HGB) option is designed to limit the minimum evaporating pressure in the cooling mode to prevent the air coil from icing. The HGB valve senses pressure at the outlet of the evaporator by an external equalizer. If the evaporator pressure decreases to 115 psig the HGB valve will begin to open and bypass hot discharge gas into the inlet of the evaporator. The valve will continue to open as needed until it reaches its maximum capacity. Upon a rise of suction pressure, the valve will begin to close back off and normal cooling operation will resume.



# Hot Gas Reheat/ Hot Gas Bypass cont.

## Hot Gas Reheat Dehumidification Overview

### Dehumidification - The Need for Reheat

With tighter construction and more and more ventilation air being introduced into buildings, there is more need now than ever for proper humidity control. Ensuring dehumidification can provide consistent employee comfort, a reduction in mold liability, a reduction in cooling costs. Reduced humidity also provides an improvement in indoor air quality (IAQ) thru lower humidity levels which can reduce allergen levels, inhibit mold and bacterial growth, and provide an improved computer environment. ASHRAE 90.1 speaks of an acceptable humidity range in all commercial buildings.

### Typical Reheat Applications

Reheat can be used wherever moisture is a problem. Schools, high latent auditorium and theaters, makeup air units\*, and computer rooms are typical applications. Although reheat equipped water source heat pumps (wshp's) can condition limited amounts of outdoor air, the percentage of this outdoor air should never exceed 50% of the return air to the unit limiting the mixed return air temperature to a minimum of 50°F. When cold entering air conditions are anticipated, hot gas bypass option should be considered to prevent air coil freeze up.

\*A dedicated outdoor air system (DOAS) should be investigated for 100% outdoor air applications.

## The Design of Reheat Equipment

Hot gas reheat can help maintain specific humidity levels and neutral air in a building. ASHRAE recommends a relative humidity range of 30-60% with levels greater than 65% making mold growth a possibility. The dehumidification relative humidity set points of 57% (on) and 52% (off) are recommended. During reheat the leaving air temperature (LAT) will approximate neutral air. The included chart (Leaving Air Temperature vs. Entering Water and Air Conditions Chart) shows the LAT vs entering water temperature (EWT) to the unit at differing entering air conditions. At 86-90°F EWT the unit will provide nearly neutral air.

## Moisture Removal Capacity

The amount of moisture removal may be calculated by subtracting the sensible cooling capacity from the total cooling capacity in the equipment performance data of the specifications catalog or submittal data. An example is shown below:

Model NLV\*080, 2600 cfm, 22 gpm, 90°F EWT

$$TC - SC = LC$$

$$78.0 - 57.8 \text{ MBtu/h} = 20.2 \text{ MBtu/h}$$

Where TC = total cooling capacity, SC=sensible capacity, LC=latent capacity

Leaving Air Temperature vs. Entering Water and Air Conditions Chart

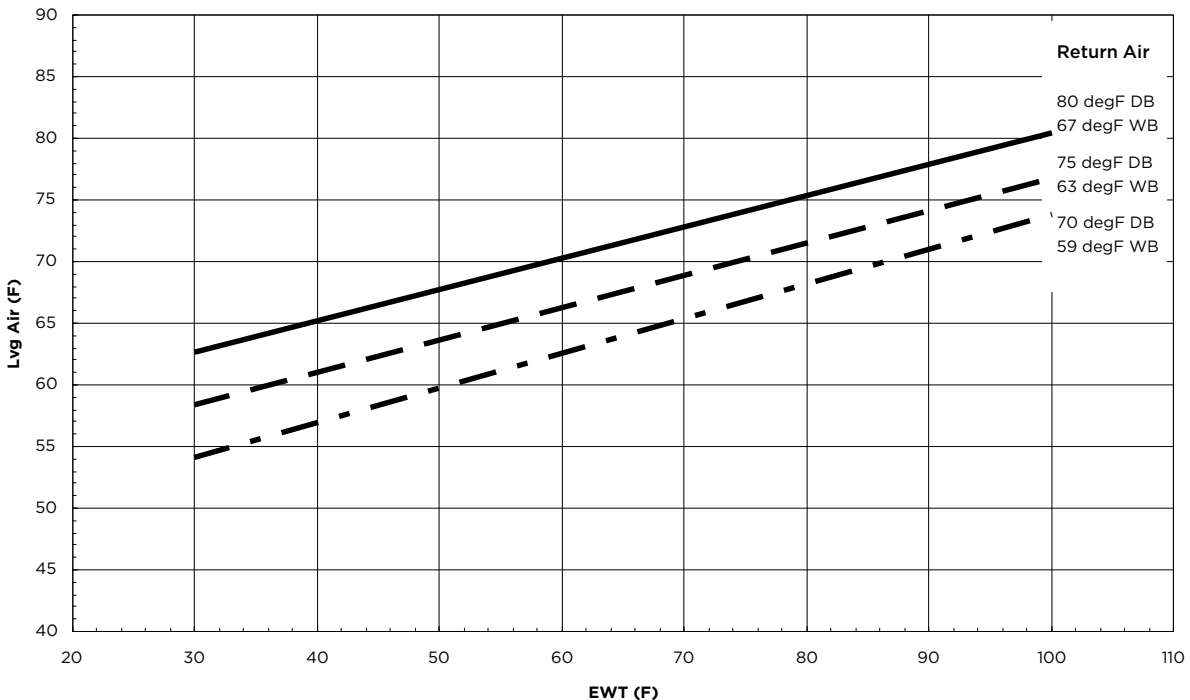

## Hot Gas Reheat/ Hot Gas Bypass cont.

### Hot Gas Reheat Dehumidification Overview cont.

Btu/hr may be converted to lbs/hr or grains per hour as shown in the equations below.

$$20,200 \text{ Btu/h} / 1,069 \text{ Btu/lb of water vapor at } 80/67 \text{ DB/WB}^\circ\text{F} = 18.90 \text{ lbs/hr}$$

$$18.90 \text{ lbs/hr} \times 7,000 \text{ grains/lb} = 132,300 \text{ grains/hr}$$

Model NLV080, 2600 cfm,

$$H \times W = SA$$

$$28 \times 25 \times 2 = 1400 \text{ in.}^2 = 9.72 \text{ ft.}^2$$

Where H=fin height of air coil, W=fin length of air coil, SA=fin surface area

Calculate air velocity, fpm, cfm / SA

$$2600 \text{ cfm} / 9.72 \text{ ft.}^2 = 267 \text{ fpm}$$

Refer to the ESP vs. Coil Velocity Table and look up the fpm to find ESP increase. If air velocity is below 250 cfm assume 0.10 increase in ESP. Interpolation of data within the table is permitted.

### External Static Pressure Adjustment

With a reheat coil option installed an adjustment for external static pressure (ESP) needs to be made. The following table will show the reduction in ESP for any model relating coil air velocity and ESP.

ESP vs. Coil Velocity Table

Coil Velocity (fpm)	250	300	350	400
ESP Increase (in. wg.)	0.10	0.14	0.17	0.20

### Hot Gas Bypass with Hot Gas Reheat Layout

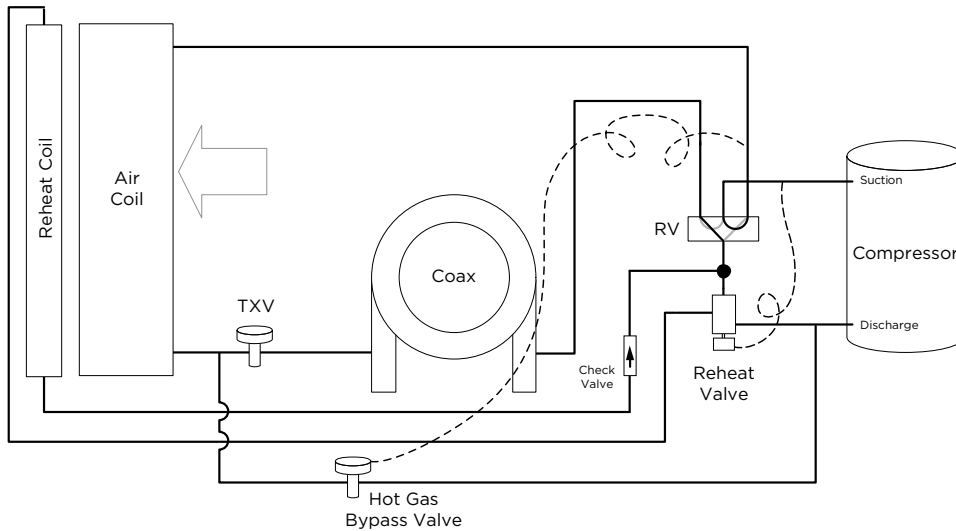

## Affinity Large Series Application Notes

### The Closed Loop Heat Pump Concept

The basic principle of a water source heat pump is the transfer of heat into water from the space during cooling, or the transfer of heat from water into the space during heating. Extremely high levels of energy efficiency are achieved as electricity is used only to move heat, not to produce it. Using a typical Affinity Large Series, one unit of electricity will move four to five units of heat.

When multiple water source heat pumps are combined on a common circulating loop, the ultimate in energy efficiency is created: The units on cooling mode are adding heat to the loop which the units in heating mode can absorb, thus removing heat from the area where cooling is needed, recovering and redistributing that heat for possible utilization elsewhere in the system. In modern commercial structures, this characteristic of heat recovery from core area heat generated by lighting, office equipment, computers, solar radiation, people or other sources, is an important factor in the high efficiency and low operating costs of closed source heat pump systems.

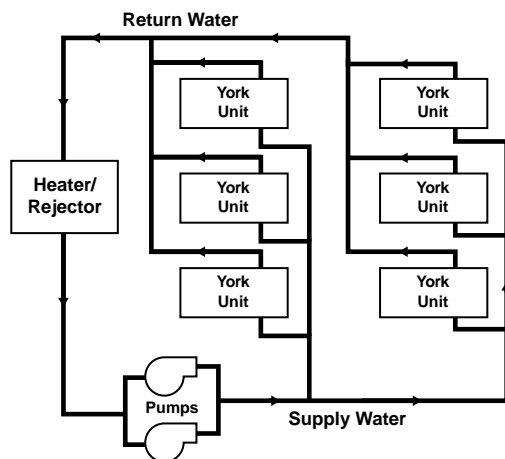

In the event that a building's net heating and cooling requirements create loop temperature extremes, Affinity Large Series units have the extended range capacity and versatility to maintain a comfortable environment for all building areas. Excess heat can be stored for later utilization or be added or removed in one of three ways; by ground-source heat exchanger loops: plate heat exchangers connected to other water sources, or conventional cooler/boiler configurations. Your sales representative has the expertise and computer software to assist in determining optimum system type for specific applications.

### The Closed Loop Advantage

A properly applied water source heat pump system offers many advantages over other systems. First costs are low because units can be added to the loop on an "as needed basis"- perfect for speculative buildings. Installed costs are low since units are self-contained and can be located adjacent to the occupied space, requiring minimal ductwork. Maintenance can be done on individual units without system shut-down. Conditions remain

comfortable since each unit operates separately, allowing cooling in one area and heating in another. Tenant spaces can be finished and added as needed. Power billing to tenants is also convenient since each unit can be individually metered: each pays for what each uses. Nighttime and/or weekend uses of certain areas are possible without heating or cooling the entire facility. A decentralized system also means if one unit should fault, the rest of the system will continue to operate normally, as well as eliminating air cross-contamination problems and expensive high pressure duct systems requiring an inefficient electric resistance reheat mode.

### The Affinity Large Series Approach

There are a number of proven choices in the type of Affinity Large Series system which would be best for any given application. Most often considered are:

#### *Closed Loop/Ground Source Vertical*

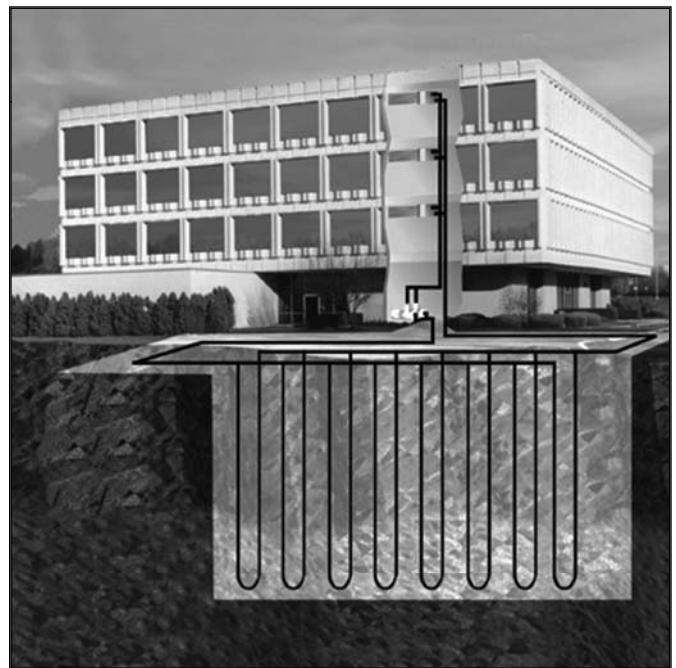

- **Closed Loop/Ground-Source Systems** utilize the stable temperatures of the earth to maintain proper water source temperatures (via vertical or horizontal closed loop heat exchangers) for Affinity Large Series extended range heat pump system. Sizes range from a single unit through many hundreds of units. When net cooling requirements cause closed loop water temperatures to rise, heat is dissipated into the cooler earth through buried high strength plastic pipe "heat exchangers." Conversely if net space heating demands cause loop heat absorption beyond that heat recovered from building core areas, the loop temperature will fall causing heat to be extracted from the earth. Due to the extended loop temperatures, AHRI/ISO 13256-1 Ground Loop Heat Pumps are required for this application.

## Affinity Large Series Application Notes cont.

Because auxiliary equipment such as a fossil fuel boiler and cooling tower are not required to maintain the loop temperature, operating and maintenance costs are very low.

Ground-source systems are most applicable in residential and light commercial buildings where both heating and cooling are desired, and on larger envelope dominated structures where core heat recovery will not meet overall heating loads. Both vertical and horizontally installed closed-loops can be used. The land space required for the "heat exchangers" is 100-250 sq. ft./ton on vertical (drilled) installations and 750-1500 sq. ft./ton for horizontal (trenched) installations. Closed loop heat exchangers can be located under parking areas or even under the building itself.

On large multi-unit systems, sizing the closed loop heat exchanger to meet only the net heating loads and assisting in the summer with a closed circuit cooling tower may be the most cost effective choice.

### **Closed Loop/Ground Source Surface Water**



• **Closed Loop/Ground-Source Surface Water Systems** also utilize the stable temperatures of Surface Water to maintain proper water source temperatures for Affinity Large Series extended range heat pump systems. These systems have all of the advantages of horizontal and vertical closed loop systems. Due to the extended loop temperatures, AHRI/ISO 13256-1 Ground Water or Ground Loop Heat Pumps are required for this application.

In cooling dominated structures, the ground-source surface water systems can be very cost effective especially where local building codes require water retention ponds for short term storage of surface run-off. Sizing requirements for the surface water is a minimum of 500 sq. ft./ton of surface area at a minimum depth of 8 feet. Your sales representative should be contacted when designs for heating dominated structures are required.

### **Closed Loop/Ground Water Plate Heat Exchanger**

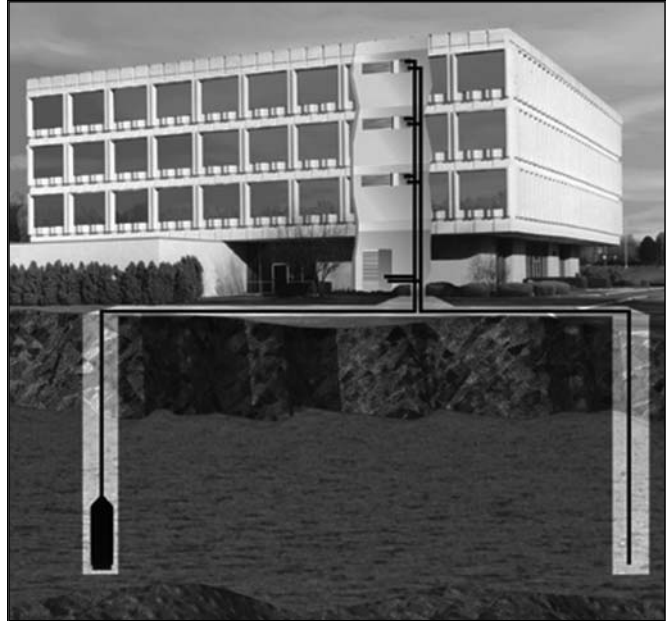

• **Closed Loop/Ground Water Plate Heat Exchanger Systems** utilize lake, ocean, well water or other water sources to maintain closed loop water temperatures in multi-unit Affinity Large Series systems. A plate frame heat exchanger isolates the units from any contaminating effects of the water source, and allows periodic cleaning of the heat exchanger during off peak hours.

Operation and benefits are similar to those for ground-source systems. Due to the extended loop temperatures, AHRI/ISO 13256-1 Ground Loop Heat Pumps are required for this application. Closed loop plate heat exchanger systems are applicable in commercial, marine, or industrial structures where the many benefits of a water source heat pump system are desired, regardless of whether the load is heating or cooling dominated.

## Affinity Large Series Application Notes cont.

### Closed Loop Cooler - Boiler

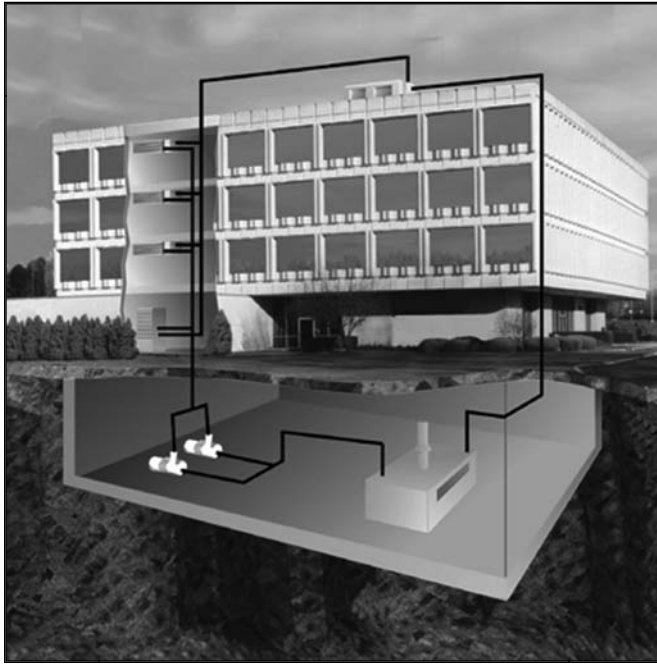

• **Closed Loop /Cooler-Boiler Systems** utilize a closed heat recovering loop with multiple water source heat pumps in the more conventional manner. Typically a boiler is employed to maintain closed loop temperatures above 60°F and a cooling tower to maintain loop temperatures below 90°F. These systems are applicable in medium to large buildings regardless of whether the load is heating or cooling dominated. Due to the moderate loop temperatures, AHRI/ISO 13256-1 Water Loop Heat Pumps are required for this application.

## Water Quality

In ground water situations where scaling could be heavy or where biological growth such as iron bacteria will be present, a closed loop system is recommended. The heat exchanger coils in ground water systems may, over a period of time, lose heat exchange capabilities due to a buildup of mineral deposits inside. These can be cleaned, but only by a qualified service mechanic, as special solutions and pumping equipment are required. Hot water

generator coils can likewise become scaled and possibly plugged. In areas with extremely hard water, the owner should be informed that the heat exchanger may require occasional flushing.

Units with cupronickel heat exchangers are recommended for open loop applications due to the increased resistance to build-up and corrosion, along with reduced wear caused by acid cleaning.

Material		Copper	90/10 Cupronickel	316 Stainless Steel
pH	Acidity/Alkalinity	7 - 9	7 - 9	7 - 9
Scaling	Calcium and Magnesium Carbonate	(Total Hardness) less than 350 ppm	(Total Hardness) less than 350 ppm	(Total Hardness) less than 350 ppm
Corrosion	Hydrogen Sulfide	Less than 0.5 ppm (rotten egg smell appears at 0.5 ppm)	10 - 50 ppm	Less than 1 ppm
	Sulfates	Less than 125 ppm	Less than 125 ppm	Less than 200 ppm
	Chlorine	Less than 0.5 ppm	Less than 0.5 ppm	Less than 0.5 ppm
	Chlorides	Less than 20 ppm	Less than 125 ppm	Less than 300 ppm
	Carbon Dioxide	Less than 50 ppm	10 - 50 ppm	10 - 50 ppm
	Ammonia	Less than 2 ppm	Less than 2 ppm	Less than 20 ppm
	Ammonia Chloride	Less than 0.5 ppm	Less than 0.5 ppm	Less than 0.5 ppm
	Ammonia Nitrate	Less than 0.5 ppm	Less than 0.5 ppm	Less than 0.5 ppm
	Ammonia Hydroxide	Less than 0.5 ppm	Less than 0.5 ppm	Less than 0.5 ppm
	Ammonia Sulfate	Less than 0.5 ppm	Less than 0.5 ppm	Less than 0.5 ppm
	Total Dissolved Solids (TDS)	Less than 1000 ppm	1000 - 1500 ppm	1000 - 1500 ppm
	LSI Index	+0.5 to -0.5	+0.5 to -0.5	+0.5 to -0.5
Iron Fouling (Biological Growth)	Iron, FE <sup>2+</sup> (Ferrous) Bacterial Iron Potential	< 0.2 ppm	< 0.2 ppm	< 0.2 ppm
	Iron Oxide	Less than 1 ppm, above this level deposition will occur	Less than 1 ppm, above this level deposition will occur	Less than 1 ppm, above this level deposition will occur
Erosion	Suspended Solids	Less than 10 ppm and filtered for max. of 600 micron size	Less than 10 ppm and filtered for max. of 600 micron size	Less than 10 ppm and filtered for max. of 600 micron size
	Threshold Velocity (Fresh Water)	< 6 ft/sec	< 6 ft/sec	< 6 ft/sec

NOTES: Grains = ppm divided by 17  
mg/L is equivalent to ppm

2/22/12

## Installation Notes

### Typical Unit Installation

#### Unit Location

Locate the unit in an indoor area that allows for easy removal of the filter and access panels. Location should have enough space for service personnel to perform maintenance or repair. Provide sufficient room to make water, electrical and duct connection(s). If the unit is located in a confined space, such as a closet, provisions must be made for return air to freely enter the space by means of a louvered door, etc. Any access panel screws that would be difficult to remove after the unit is installed should be removed prior to setting the unit. On horizontal units, allow adequate room below the unit for a condensate drain trap and do not locate the unit above supply piping. **Care should be taken when units are located in unconditioned spaces to prevent damage from frozen water lines and excessive heat that could damage electrical components.**

#### Installing Vertical Units

Vertical units are available in left or right air return configurations. Top flow vertical units should be mounted level on a vibration absorbing pad slightly larger than the base to provide isolation between the unit and the floor. It is not necessary to anchor the unit to the floor.

**WARNING: Before performing service or maintenance operations on a system, turn off main power switches to the indoor unit. If applicable, turn off the accessory heater power switch. Electrical shock could cause personal injury.**

Installing and servicing heating and air conditioning equipment can be hazardous due to system pressure and electrical components. Only trained and qualified service personnel should install, repair or service heating and air conditioning equipment. Untrained personnel can perform the basic maintenance functions of cleaning coils and cleaning and replacing filters.

All other operations should be performed by trained service personnel. When working on heating and air conditioning equipment, observe precautions in the literature, tags and labels attached to the unit and other safety precautions that may apply. Follow all safety codes. Wear safety glasses and work gloves. Use a quenching cloth for brazing operations and have a fire extinguisher available.

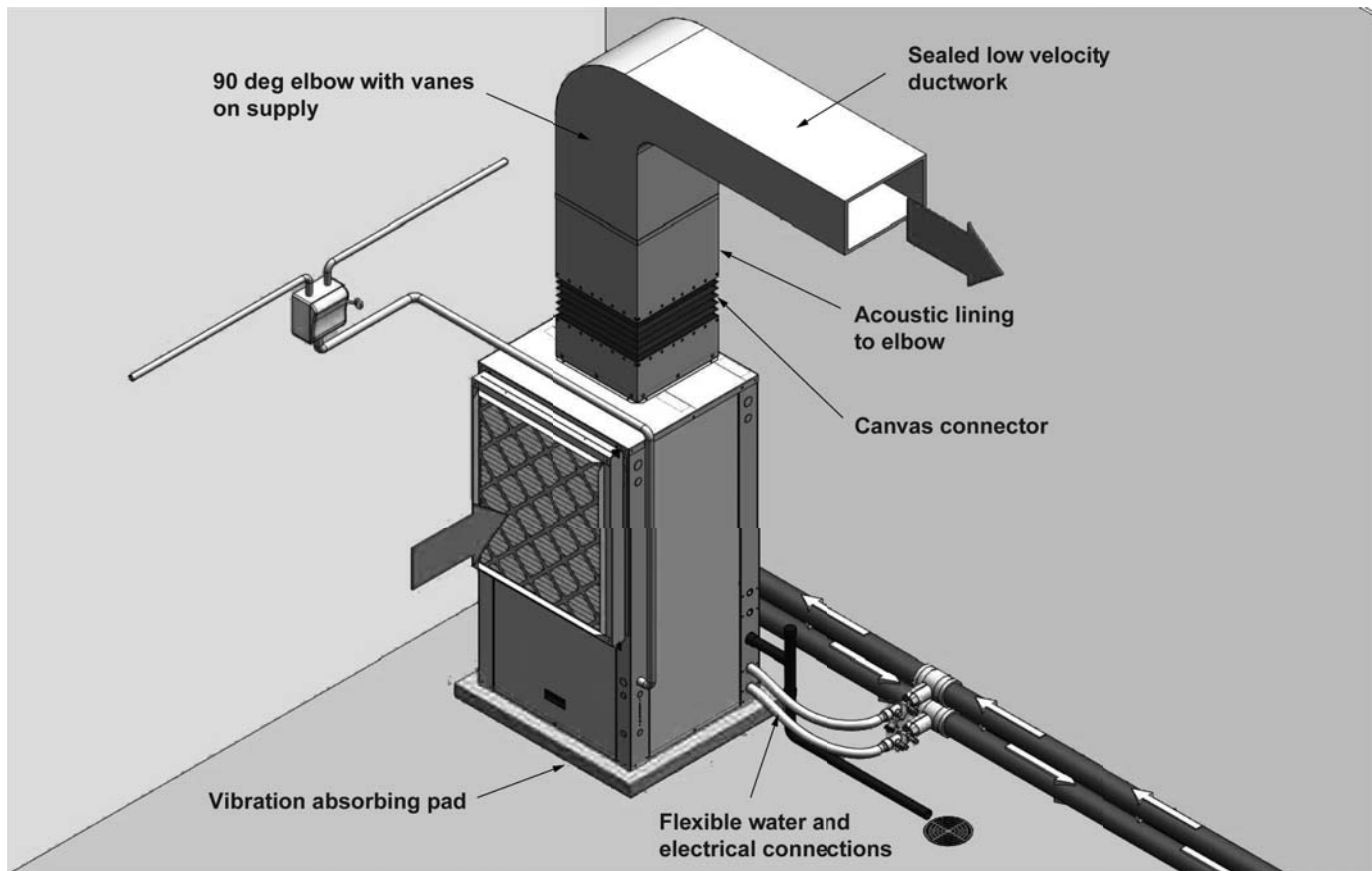

## Installation Notes cont.

### Installing Horizontal Units

Horizontal units are available with side or end discharge and may be field converted from one to the other. Horizontal units are normally suspended from a ceiling by four 1/2 in. diameter threaded rods. The rods are usually attached to the unit by hanger bracket kits furnished with each unit. Lay out the threaded rods per the dimensions below. Assemble the hangers to the unit as shown. When attaching the hanger rods to the bracket, a double nut is required since vibration could loosen a single nut.

**NOTE:** The unit should be pitched approximately 1/4-inch towards the drain in both directions to facilitate the removal of condensate.

Some installations require placing a horizontal unit on an attic floor. In this case, the unit should be set in a full size secondary drain pan on top of a vibration absorbing pad. The secondary drain pan prevents possible condensate overflow or water leakage damage to the ceiling. The secondary drain pan is usually placed on a plywood base isolated from the ceiling joists by additional layers of vibration absorbing material. Insulate supply plenum and use at least one 90° elbow to reduce noise.

**CAUTION:** Do not use rods smaller than 1/2-inch diameter since they may not be strong enough to support the unit. The rods must be securely anchored to the ceiling.

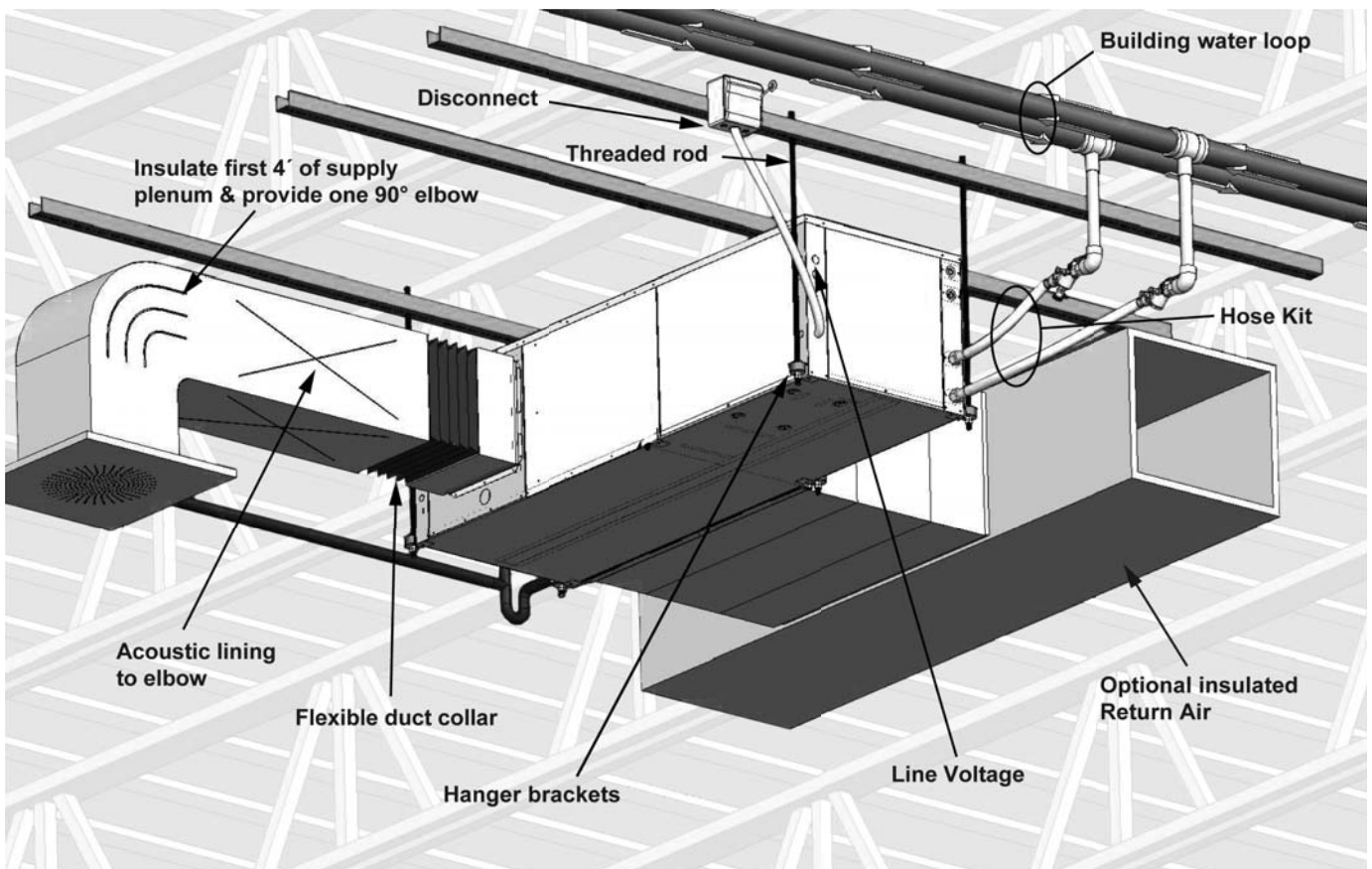

## Installation Notes cont.

### Water Piping

Piping is usually designed as 'reverse return' to equalize flow paths through each unit. A short flexible pressure rated hose is used to make connection to the fixed building piping system. This hose is typically stainless steel braid and includes a swivel fitting on one end for easy removal and is flexible to help isolate the unit for quieter operation. Isolation valves for servicing, y-strainers for filtering and memory-stop flow valve or a balancing valve can be provided for consistent water flow through the unit.

All unit source water connections are fittings that accept a male pipe thread (MPT). Insert the connectors by hand, then tighten the fitting with a wrench to provide a leakproof joint. The open and closed loop piping system should include pressure/temperature ports for serviceability. The proper water flow must be provided to each unit whenever the unit operates. To assure proper flow, use pressure/temperature ports to determine the flow rate. These ports should be located at the supply and return water connections on the unit. The proper flow rate cannot be accurately set without measuring the water pressure drop through the refrigerant-to-water heat exchanger. Limit hose length to 10 feet per connection. Check carefully for water leaks.

### Condensate Drain

On vertical units, the internal condensate drain assembly consists of a drain tube which is connected to the drain pan, a 3/4 in. or 1 in. copper female adapter and a flexible connecting hose. On vertical upflow units, a condensate hose is inside all cabinets as a trapping loop; therefore, an external trap is not necessary. On horizontal units, a PVC stub is provided for condensate drain piping connection. An external trap is required (see below). If a vent is necessary, an open stand pipe may be applied to a tee in the field-installed condensate piping. In order to work properly, the vent must be after the trap and away from the unit.

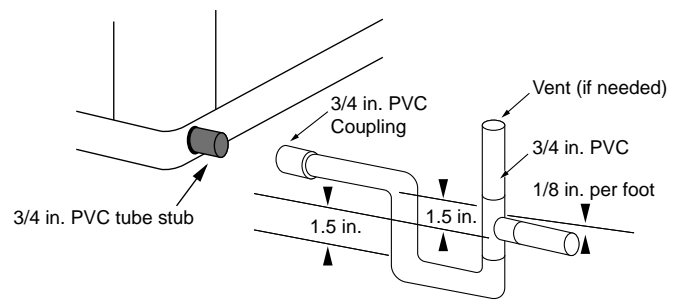



## Installation Notes cont.

### Acoustical Considerations and Equipment Sound Performance

#### Sound Performance

The Affinity Large Series is third party sound rated in accordance with AHRI 260.

#### Recommendations for Noise Reduction

##### Horizontal Unit Location

- Specify equipment with quietest sound power ratings
- Do not locate units above areas with a required NC 40 or less
- Space WSHP at least 10 ft (3m) apart to avoid noise summing of multiple units in a space.
- Maximize the height of the unit above the ceiling (horizontal).
- Suspend unit with isolation grommets that are appropriately rated to reduce vibrations (horizontal).

##### Vertical Unit Location

- Specify equipment with quietest sound power ratings
- Space WSHP at least 10 ft (3m) apart to avoid noise summing of multiple units in a space.
- Acoustic ceiling coatings can greatly reduce noise levels in mechanical rooms.
- Mount unit on a sound absorbing pad, extruded polystyrene, rubber or cork pad.

#### Ductwork

- Ensure return air grilles will not allow line of site noise to transfer to adjacent space. Use a sound barrier or some other material to isolate the grille from the unit. A supply grille, boot and short piece of flex duct pointed away from the unit can greatly attenuate equipment noise.
- Use a canvas isolation duct connector at the supply and return duct connection of the unit.
- Internally line the discharge and return duct within the first 4-8 feet of unit with acoustic insulation. Install an internally lined 'L' shaped return duct elbow at return grille. Face the elbow away from adjacent units.
- Always install at least one 90° elbow in the discharge duct to eliminate line of sight noise transmission of the blower.
- Use turning vanes at all elbows and tees to reduce turbulence.
- Limit supply duct velocities to less than 1000 fpm
- Design and install ductwork as stiff as possible
- Allow 3 duct diameters both up and down stream of the unit before any fittings or transitions are installed.
- Use duct sealant on all duct joints.
- Install a short (2-4') of flex duct on all branch ducts just prior to discharge boot or diffuser to reduce vibration and duct sound prior to delivery in the room.
- Locate the branch duct balancing damper as far away from the diffuser as possible.
- In ceiling plenum systems, install an internally lined 'L' shaped return duct elbow at unit. Face the elbow away from adjacent units (horizontal).

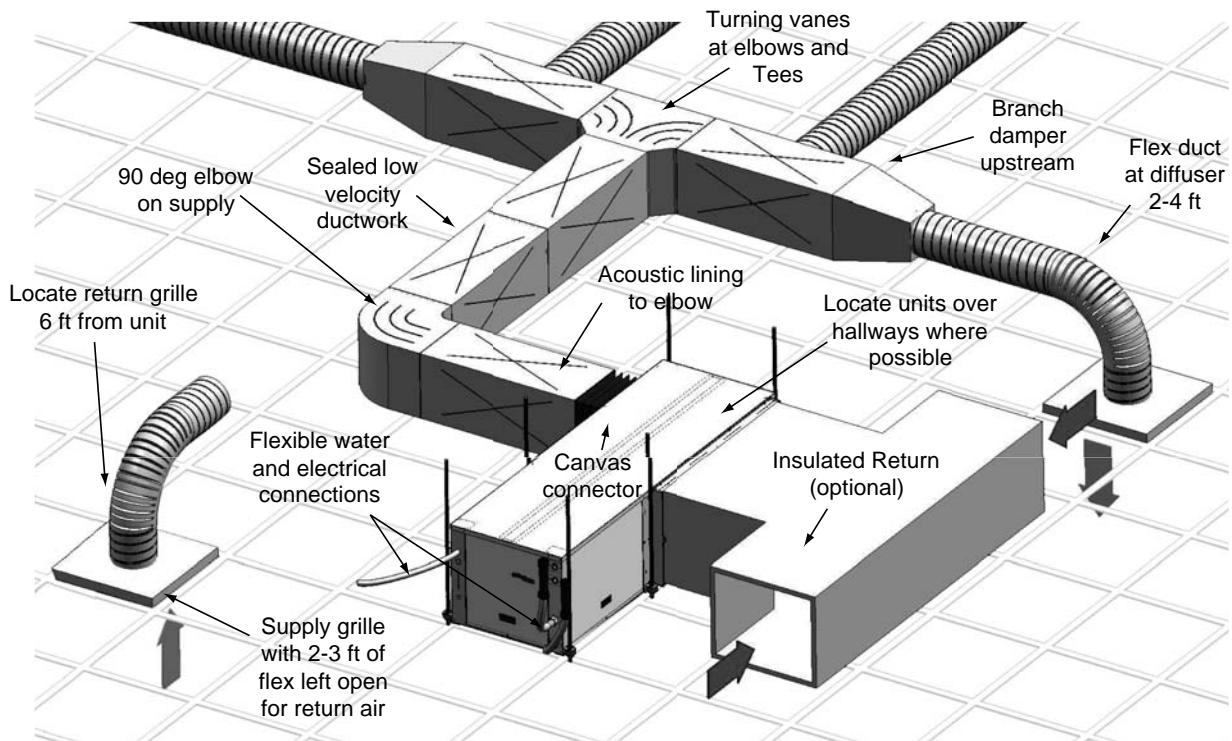

# Vertical Dimensional Data

## 7-10 Tons

### TOP DISCHARGE

### SIDE DISCHARGE

**Legend**  
 AP = Alternate Service Panel  
 BP = Blower Service Panel  
 CP = Control Access Panel  
 CMP = Compressor Service Panel

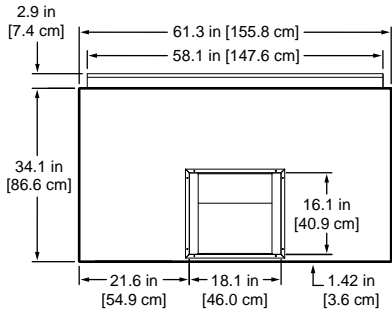
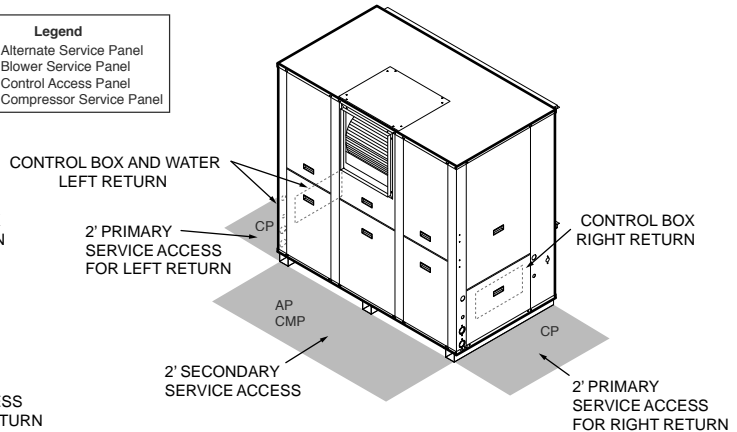
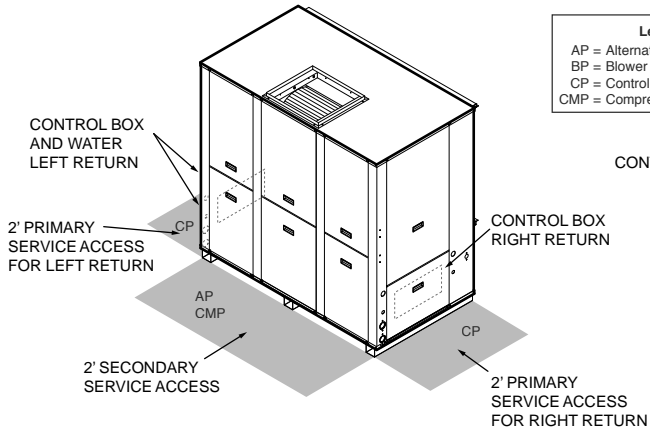

**TOP VIEW**  
Left or Right Return

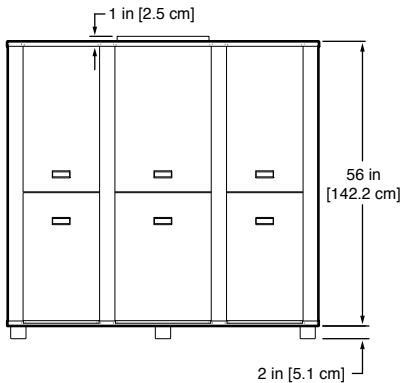
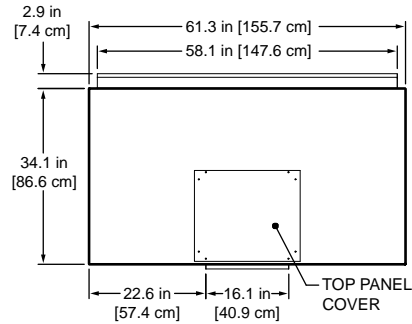

**SIDE VIEW**  
Left or Right Return

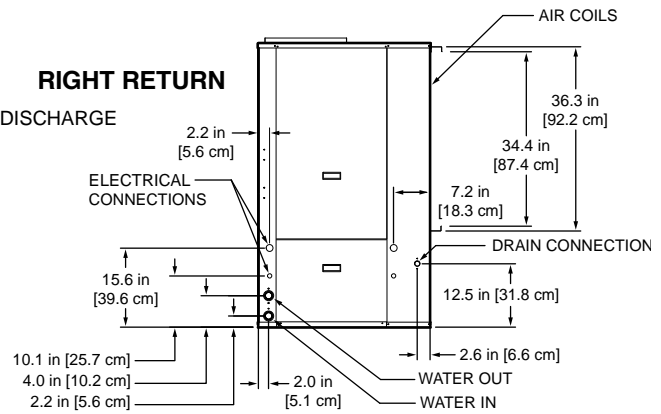
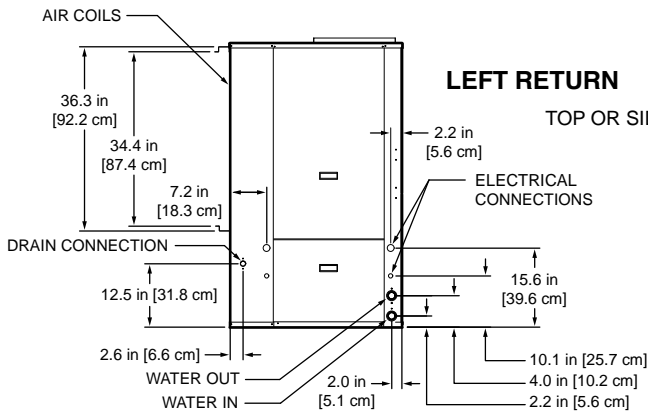
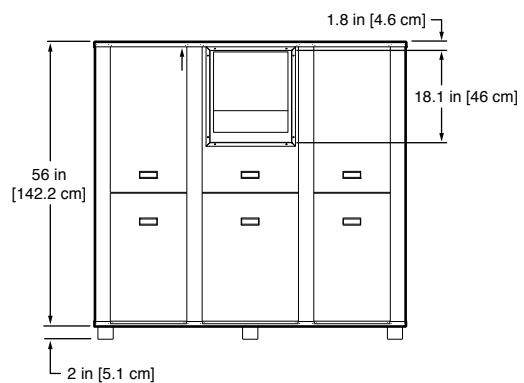

# Vertical Dimensional Data cont.

## 13-25 Tons

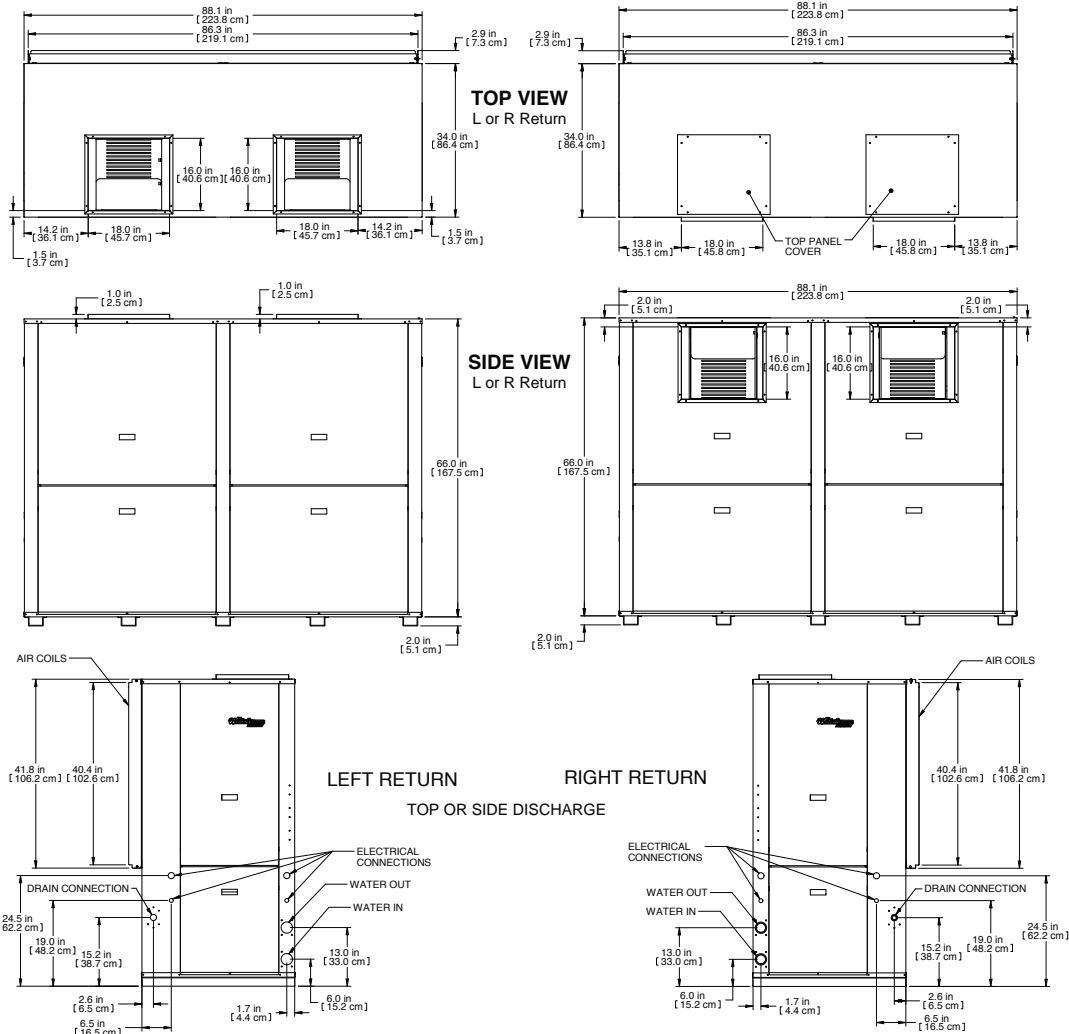
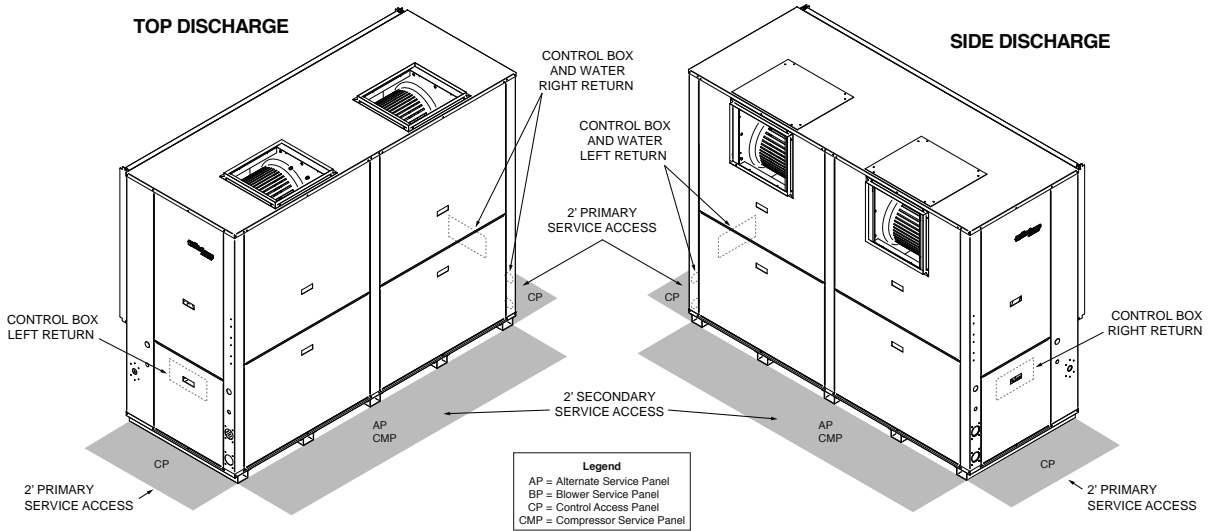

REV 8/16/07

# Horizontal Dimensional Data

## 7-10 Tons

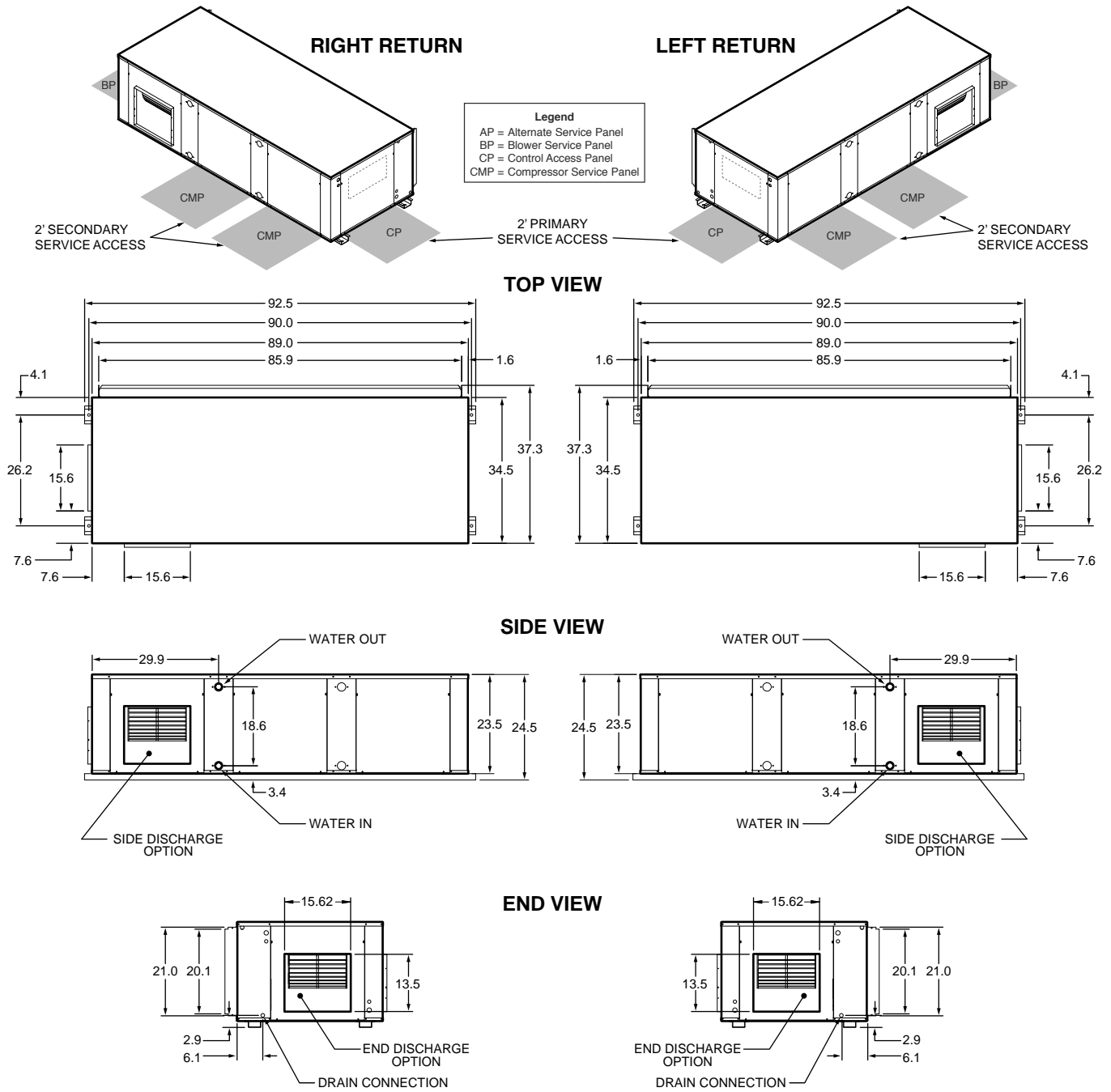

REV 4/28/08

# Hanger Bracket Locations

## Mounting Rod Layout - Left or Right Return

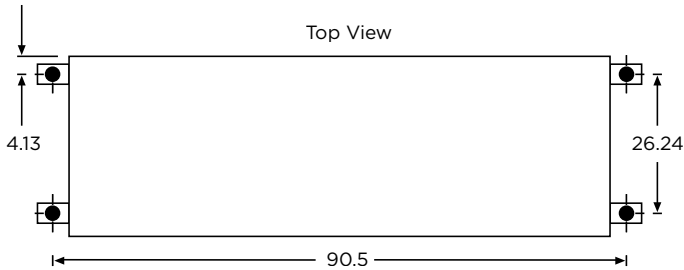

## Mounting Hardware

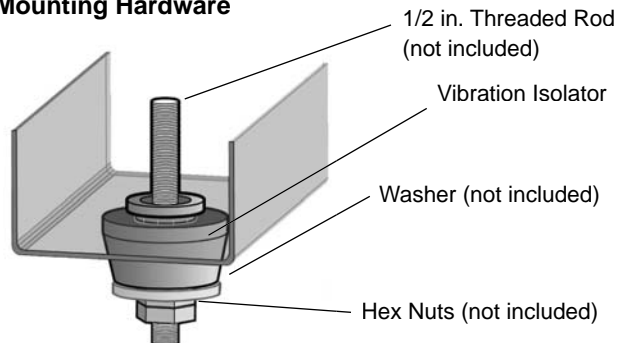

## Horizontal Unit Corner Weight Distribution

Model	Return / Discharge	A Front Left	B Front Right	C Back Right	D Back Left
080 - 120	Left / Side or End	30%	26%	22%	22%
	Right / Side or End	26%	30%	22%	22%

Approximate

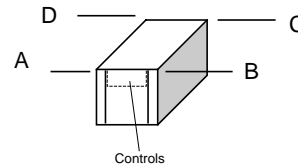

# Physical Data

Model	Horizontal			Vertical						
	080	095	120	080	095	120	160	180	240	300
Compressor (2 each)	Copeland Scroll			Copeland Scroll						
Factory Charge R410A, oz [kg] (per circuit)	74 [2.10]	84 [2.38]	92 [2.61]	78 [2.21]	86 [2.44]	100 [2.83]	176 [4.99]	178 [5.05]	236 [6.69]	240 [6.80]
<b>PSC Fan Motor &amp; Blower</b>										
Fan Motor- hp [W]	1.5 [1120]	2.0 [1492]	3.0 [2238]	1.0 (746)	1.5 (1120)	2.0 (1492)	1.0 (746)	1.5 (1120)	2.0 (1492)	3.0 (2238)
Blower Wheel Size (Dia x W), in. [mm]	12 x 12 [305 x 305]	12 x 12 [305 x 305]	12 x 12 [305 x 305]	15 x 11 [381 x 280]	15 x 11 [381 x 280]	15 x 11 [381 x 280]	15 x 11 (2) [381 x 280]	15 x 11 (2) [381 x 280]	15 x 11 (2) [381 x 280]	15 x 11 (2) [381 x 280]
<b>Coax and Water Piping</b>										
Water Connections Size - FPT - in [mm]	1 1/4 [31.75]	1 1/4 [31.75]	1 1/4 [31.75]	1 1/4 [31.75]	1 1/4 [31.75]	1 1/4 [31.75]	2 [50.8]	2 [50.8]	2 [50.8]	2 [50.8]
HWG Connection Size - FPT - in [mm]	N/A	N/A	N/A	N/A	N/A	N/A	N/A	N/A	N/A	N/A
Coax & Piping Water Volume - gal [l]	2.87 [10.85]	3.20 [12.13]	3.46 [13.11]	2.87 [10.85]	3.20 [12.13]	3.46 [13.11]	6.50 [24.61]	6.50 [24.61]	7.00 [26.50]	7.00 [26.50]
<b>Air Coil &amp; Filters</b>										
Air Coil Dimensions (H x W), in. [mm]	20 x 35 [508 x 889]	20 x 40 [508 x 1016]	20 x 40 [508 x 1016]	28 x 25 (711 x 635)	32 x 25 (813 x 635)	36 x 25 (915 x 635)	40 x 40 (2) [1016 x 1016]	40 x 40 (2) [1016 x 1016]	40 x 40 (2) [1016 x 1016]	40 x 40 (2) [1016 x 1016]
Air Coil Total Face Area, ft2 [m2]	9.74 [0.91]	11.11 [1.03]	11.11 [1.03]	9.72 (0.90)	11.10 (1.03)	12.50 (1.16)	22.22 [2.06]	22.22 [2.06]	22.22 [2.06]	22.22 [2.06]
Air Coil Tube Size, in [mm]	3/8 (9.52)	3/8 (9.52)	3/8 (9.52)	3/8 (9.52)	3/8 (9.52)	3/8 (9.52)	3/8 (9.52)	3/8 (9.52)	3/8 (9.52)	3/8 (9.52)
Air Coil Number of rows	3	3	3	3	3	4	3	3	3	3
Filter Standard - 2" [50.8], in [mm]	20 x 20 (3) [508 x 508] 20 x 25 (1) [508 x 635]	20 x 20 (3) [508 x 508] 20 x 25 (1) [508 x 635]	20 x 20 (3) [508 x 508] 20 x 25 (1) [508 x 635]	28 x 36 (1) (711 x 914) 30 x 36 (1) (762 x 914)	28 x 36 (1) (711 x 914) 30 x 36 (1) (762 x 914)	28 x 36 (1) (711 x 914) 30 x 36 (1) (762 x 914)	40 x 42 (2) (1016 x 1067)	40 x 42 (2) (1016 x 1067)	40 x 42 (2) (1016 x 1067)	40 x 42 (2) (1016 x 1067)
Weight - Operating, lb [kg]	700 [318]	796 [361]	843 [382]	644 [292]	762 [346]	849 [385]	1175 [533]	1195 [542]	1350 [612]	1400 [635]
Weight - Packaged, lb [kg]	690 [313]	785 [356]	830 [376]	620 [281]	735 [333]	820 [372]	1180 [535]	1200 [544]	1355 [614]	1405 [637]

# Electrical Data

Model	Rated Voltage	Voltage Min/Max	Compressor*			Blower Motor FLA***	Blower HP ***	Total Unit FLA	Min Circ Amp	Max Fuse/HACR
			MCC	RLA	LRA					
<b>Horizontal</b>										
080	208-230/60/3	187/253	16.3	10.4	88.0	4.8	1.5	25.7	28.3	35.0
	460/60/3	414/506	9.0	5.8	38.0	2.4	1.5	13.9	15.4	20.0
	575/60/3	518/632	5.9	3.8	36.5	1.9	1.5	9.5	10.4	10.0
080**	208-230/60/3	187/253	16.3	10.4	88.0	6.2	2.0	27.1	29.7	40.0
	460/60/3	414/506	9.0	5.8	38.0	3.1	2.0	14.6	16.1	20.0
	575/60/3	518/632	5.9	3.8	36.5	2.5	2.0	10.1	11.0	10.0
095	208-230/60/3	187/253	21.2	13.6	83.1	6.2	2.0	33.3	36.7	50.0
	460/60/3	414/506	9.5	6.1	41.0	3.1	2.0	15.3	16.8	20.0
	575/60/3	518/632	7.8	5.0	34.0	2.5	2.0	12.5	13.7	15.0
095**	208-230/60/3	187/253	21.2	13.6	83.1	9.2	3.0	36.3	39.7	50.0
	460/60/3	414/506	9.5	6.1	41.0	4.3	3.0	16.5	18.0	20.0
	575/60/3	518/632	7.8	5.0	34.0	3.4	3.0	13.4	14.6	15.0
120	208-230/60/3	187/253	24.9	15.9	110.0	9.2	3.0	41.1	45.1	60.0
	460/60/3	414/506	12.1	7.7	52.0	4.3	3.0	19.8	21.7	25.0
	575/60/3	518/632	8.9	5.7	38.9	3.4	3.0	14.8	16.2	20.0
<b>Vertical</b>										
080	208-230/60/3	187/253	16.3	10.4	88.0	3.6	1.0	24.5	27.1	35.0
	460/60/3	414/506	9.0	5.8	38.0	1.8	1.0	13.3	14.8	20.0
	575/60/3	518/632	5.9	3.8	36.5	1.5	1.0	9.0	9.9	10.0
080**	208-230/60/3	187/253	16.3	10.4	88.0	4.8	1.5	25.7	28.3	35.0
	460/60/3	414/506	9.0	5.8	38.0	2.4	1.5	13.9	15.4	20.0
	575/60/3	518/632	5.9	3.8	36.5	1.9	1.5	9.5	10.4	10.0
095	208-230/60/3	187/253	21.2	13.6	83.1	4.8	1.5	31.9	35.3	45.0
	460/60/3	414/506	9.5	6.1	41.0	2.4	1.5	14.6	16.1	20.0
	575/60/3	518/632	7.8	5.0	34.0	1.9	1.5	11.9	13.1	15.0
095**	208-230/60/3	187/253	21.2	13.6	83.1	6.2	2.0	33.3	36.7	50.0
	460/60/3	414/506	9.5	6.1	41.0	3.1	2.0	15.3	16.8	20.0
	575/60/3	518/632	7.8	5.0	34.0	2.5	2.0	12.5	13.7	15.0
120	208-230/60/3	187/253	24.9	15.9	110.0	6.2	2.0	38.1	42.1	50.0
	460/60/3	414/506	12.1	7.7	52.0	3.1	2.0	18.6	20.5	25.0
	575/60/3	518/632	8.9	5.7	38.9	2.5	2.0	13.9	15.3	20.0
120**	208-230/60/3	187/253	24.9	15.9	110.0	9.2	3.0	41.1	45.1	60.0
	460/60/3	414/506	12.1	7.7	52.0	4.3	3.0	19.8	21.7	25.0
	575/60/3	518/632	8.9	5.7	38.9	3.4	3.0	14.8	16.2	20.0
160	208-230/60/3	187/253	35.0	22.4	149.0	3.6	1.0	52.0	57.6	80.0
	460/60/3	414/506	16.5	10.6	75.0	1.8	1.0	24.8	54.0	35.0
	575/60/3	518/632	12.0	7.7	54.0	1.5	1.0	18.4	20.3	25.0
160**	208-230/60/3	187/253	35.0	22.4	149.0	4.8	1.5	54.4	60.0	80.0
	460/60/3	414/506	16.5	10.6	75.0	2.4	1.5	26.0	28.7	35.0
	575/60/3	518/632	12.0	7.7	54.0	1.9	1.5	19.2	21.1	25.0
180	208-230/60/3	187/253	36.2	23.2	164.0	4.8	1.5	56.0	61.8	80.0
	460/60/3	414/506	17.5	11.2	75.0	2.4	1.5	27.2	30.0	40.0
	575/60/3	518/632	12.3	7.9	54.0	1.9	1.5	19.6	21.6	25.0
180**	208-230/60/3	187/253	36.2	23.2	164.0	6.2	2.0	58.8	64.6	80.0
	460/60/3	414/506	17.5	11.2	75.0	3.1	2.0	28.6	31.4	40.0
	575/60/3	518/632	12.3	7.9	54.0	2.5	2.0	20.8	22.8	30.0
240	208-230/60/3	187/253	47.0	30.1	225.0	6.2	2.0	72.6	80.1	110.0
	460/60/3	414/506	26.0	16.6	114.0	3.1	2.0	39.5	43.6	60.0
	575/60/3	518/632	19.0	12.2	80.0	2.5	2.0	29.3	32.4	40.0
240**	208-230/60/3	187/253	47.0	30.1	225.0	9.2	3.0	78.6	86.1	110.0
	460/60/3	414/506	26.0	16.6	114.0	4.3	3.0	41.9	46.0	60.0
	575/60/3	518/632	19.0	12.2	80.0	3.4	3.0	31.1	34.2	45.0
300	208-230/60/3	187/253	52.0	33.3	239.0	9.2	3.0	85.0	93.3	125.0
	460/60/3	414/506	28.0	17.9	125.0	4.3	3.0	44.4	48.9	60.0
	575/60/3	518/632	20.0	12.8	80.0	3.4	3.0	32.4	35.6	45.0

\*Ratings per each compressor - unit supplied with two

\*\*With optional motor

\*\*\*Ratings per each blower motor - Vertical models 160-300 supplied with two.

9/10/07

HACR circuit breaker in USA only  
All fuses Class RK-5

# Horizontal YL080 - Blower Performance Data

## Belt Drive

Airflow in CFM with dry coil and clean air filter.

Rated CFM		External Static Pressure (in. w.g.)															
		0.0	0.1	0.2	0.3	0.4	0.5	0.6	0.7	0.8	0.9	1.0	1.1	1.2	1.3	1.4	1.5
2200	MTR/SHEAVE				1.0	1.0	1.0	1.0	1.0	<b>4.0</b>	<b>4.0</b>	<b>4.0</b>	<b>4.0</b>	<b>5.0</b>	<b>5.0</b>	<b>5.0</b>	<b>5.0</b>
	BHP				0.37	0.40	0.43	0.47	0.52	<b>0.59</b>	<b>0.65</b>	<b>0.71</b>	<b>0.75</b>	<b>0.78</b>	<b>0.81</b>	<b>0.86</b>	<b>0.90</b>
	RPM				583	624	665	706	747	<b>770</b>	<b>791</b>	<b>821</b>	<b>865</b>	<b>911</b>	<b>957</b>	<b>986</b>	<b>1015</b>
	TURNS OPEN				5.0	4.0	3.0	2.0	1.0	<b>3.0</b>	<b>2.0</b>	<b>1.0</b>	<b>0.0</b>	<b>3.5</b>	<b>3.0</b>	<b>2.5</b>	<b>2.0</b>
2400	MTR/SHEAVE			1.0	1.0	1.0	1.0	1.0	<b>4.0</b>	<b>4.0</b>	<b>4.0</b>	<b>4.0</b>	<b>5.0</b>	<b>5.0</b>	<b>5.0</b>	<b>5.0</b>	
	BHP			0.45	0.49	0.53	0.59	0.62	<b>0.67</b>	<b>0.70</b>	<b>0.74</b>	<b>0.79</b>	<b>0.85</b>	<b>0.88</b>	<b>0.91</b>	<b>0.95</b>	<b>1.08</b>
	RPM			582	623	664	705	746	<b>765</b>	<b>790</b>	<b>820</b>	<b>861</b>	<b>906</b>	<b>938</b>	<b>970</b>	<b>1004</b>	<b>1030</b>
	TURNS OPEN			5.0	4.0	3.0	2.0	1.0	<b>3.0</b>	<b>2.0</b>	<b>1.0</b>	<b>0.0</b>	<b>4.0</b>	<b>3.0</b>	<b>2.5</b>	<b>2.0</b>	<b>1.5</b>
2600	MTR/SHEAVE			1.0	1.0	1.0	1.0	3.0	3.0	3.0	3.0	3.0	<b>5.0</b>	<b>5.0</b>	<b>5.0</b>	<b>5.0</b>	
	BHP			0.51	0.56	0.62	0.66	0.69	0.73	0.76	0.84	0.90	<b>0.93</b>	<b>0.96</b>	<b>1.04</b>	<b>1.12</b>	<b>1.17</b>
	RPM			602	643	684	726	760	783	805	853	877	<b>916</b>	<b>954</b>	<b>988</b>	<b>1021</b>	<b>1051</b>
	TURNS OPEN			4.5	3.5	2.5	1.5	4.0	3.5	2.5	2.0	1.5	<b>3.5</b>	<b>3.0</b>	<b>2.5</b>	<b>1.5</b>	<b>1.0</b>
2800	MTR/SHEAVE		1.0	1.0	1.0	1.0	1.0	3.0	3.0	3.0	3.0	3.0	<b>5.0</b>	<b>5.0</b>	<b>5.0</b>	<b>5.0</b>	
	BHP		0.53	0.58	0.64	0.69	0.76	0.79	0.80	0.94	0.99	1.03	<b>1.15</b>	<b>1.16</b>	<b>1.17</b>	<b>1.27</b>	
	RPM		581	622	663	704	744	776	802	851	876	900	<b>951</b>	<b>976</b>	<b>1001</b>	<b>1033</b>	
	TURNS OPEN		5.0	4.0	3.0	2.0	1.0	3.5	3.0	<b>2.0</b>	1.5	1.0	<b>3.0</b>	<b>2.5</b>	<b>2.0</b>	<b>1.5</b>	
3000	MTR/SHEAVE	1.0	1.0	1.0	1.0	1.0	3.0	3.0	3.0	3.0	3.0	<b>5.0</b>	<b>5.0</b>	<b>5.0</b>	<b>5.0</b>	<b>5.0</b>	
	BHP	0.59	0.66	0.73	0.80	0.87	0.90	0.92	1.07	1.08	1.10	<b>1.30</b>	<b>1.33</b>	<b>1.35</b>	<b>1.40</b>	<b>1.44</b>	
	RPM	580	621	662	702	743	775	801	848	873	898	<b>949</b>	<b>973</b>	<b>997</b>	<b>1022</b>	<b>1046</b>	
	TURNS OPEN	5.0	4.0	3.0	2.0	1.0	3.5	3.0	2.0	1.5	1.0	<b>3.0</b>	<b>2.5</b>	<b>2.0</b>	<b>1.5</b>	<b>1.0</b>	
3200	MTR/SHEAVE	1.0	1.0	1.0	1.0	3.0	3.0	3.0	3.0	3.0	<b>5.0</b>	<b>5.0</b>	<b>5.0</b>	<b>5.0</b>	<b>5.0</b>		
	BHP	0.72	0.81	0.90	0.98	1.02	1.04	1.19	1.21	1.23	<b>1.44</b>	<b>1.47</b>	<b>1.51</b>	<b>1.54</b>	<b>1.57</b>		
	RPM	620	661	701	741	773	799	846	871	895	<b>946</b>	<b>970</b>	<b>994</b>	<b>1019</b>	<b>1043</b>		
	TURNS OPEN	4.0	3.0	2.0	1.0	3.5	3.0	2.0	1.5	1.0	<b>3.0</b>	<b>2.5</b>	<b>2.0</b>	<b>1.5</b>	<b>1.0</b>		
3400	MTR/SHEAVE	1.0	1.0	1.0	3.0	3.0	3.0	3.0	3.0	<b>5.0</b>	<b>5.0</b>	<b>5.0</b>	<b>5.0</b>	<b>5.0</b>			
	BHP	0.87	0.98	1.08	1.12	1.16	1.31	1.34	1.36	<b>1.58</b>	<b>1.62</b>	<b>1.65</b>	<b>1.69</b>	<b>1.73</b>			
	RPM	660	700	740	772	797	844	869	893	<b>944</b>	<b>968</b>	<b>992</b>	<b>1016</b>	<b>1040</b>			
	TURNS OPEN	3.0	2.0	1.0	3.5	3.0	2.0	1.5	1.0	<b>3.0</b>	<b>2.5</b>	<b>2.0</b>	<b>1.5</b>	<b>1.0</b>			

07/25/07

**Bold Face Requires Larger 2 HP Motor**

A=Std Static/Std Mtr;B=Low Static/Std. Mtr;C=High Static/Std. Mtr;D=Std Static/Large Mtr;E=High Static/Large Mtr

Units factory shipped with standard static sheave and drive at 2.5 turns open (2600 cfm @ 0.4 in. ESP). Other speeds require field selection.

ISO/AHRI rating point with standard static sheave and drive at 1.5 turns open (2600 cfm @ 0.5 in. ESP). Other speeds require field selection.

For applications requiring higher static pressures, contact your local representative.

Performance data does not include drive losses and is based on sea level conditions.

Do not operate in gray region. "na" = information not available at time of printing.

All airflow is rated at lowest Voltage if unit is dual Voltage rated, i.e. 208V for 208-230V units.

For wet coil performance first calculate the face velocity of the air coil (Face Velocity [fpm] = Airflow [cfm] / Face Area [sq ft]).

Then for velocities of 200 fpm reduce the static capability by 0.03 in. wg, 300 fpm by 0.08 in. wg, and 400 fpm by 0.12in. wg.

# Horizontal YL095 - Blower Performance Data

## Belt Drive

Airflow in CFM with dry coil and clean air filter.

Rated CFM	External Static Pressure (in. w.g.)																	
	0.0	0.1	0.2	0.3	0.4	0.5	0.6	0.7	0.8	0.9	1.0	1.2	1.4	1.6	1.8	2.0		
2600	MTR/SHEAVE			2.0	2.0	2.0	2.0	1.0	1.0	1.0	1.0	1.0	<b>4.0</b>	<b>4.0</b>	<b>4.0</b>	<b>4.0</b>	<b>5.0</b>	
	BHP			0.44	0.47	0.52	0.57	0.66	0.78	0.79	0.80	0.92	<b>0.97</b>	<b>1.08</b>	<b>1.18</b>	<b>1.37</b>	<b>1.56</b>	
	RPM			584	625	667	708	757	806	831	856	905	<b>960</b>	<b>1021</b>	<b>1082</b>	<b>1142</b>	<b>1202</b>	
	URNS OPEN			5.0	4.0	3.0	2.0	4.0	3.0	2.5	2.0	1.0	<b>3.0</b>	<b>2.0</b>	<b>1.0</b>	<b>0.0</b>	<b>3.0</b>	
2800	MTR/SHEAVE		2.0	2.0	2.0	2.0	1.0	1.0	1.0	1.0	1.0	<b>4.0</b>	<b>4.0</b>	<b>4.0</b>	<b>4.0</b>	<b>5.0</b>	<b>5.0</b>	
	BHP		0.51	0.56	0.61	0.67	0.77	0.89	0.90	0.91	1.06	<b>1.11</b>	<b>1.14</b>	<b>1.38</b>	<b>1.44</b>	<b>1.59</b>	<b>1.73</b>	
	RPM		583	625	665	707	756	804	829	854	902	<b>933</b>	<b>982</b>	<b>1055</b>	<b>1100</b>	<b>1156</b>	<b>1212</b>	
	URNS OPEN		5.0	4.0	3.0	2.0	4.0	3.0	2.5	2.0	1.0	<b>3.5</b>	<b>2.5</b>	<b>1.5</b>	<b>0.5</b>	<b>3.5</b>	<b>2.5</b>	
3000	MTR/SHEAVE	2.0	2.0	2.0	2.0	1.0	1.0	1.0	1.0	1.0	1.0	<b>4.0</b>	<b>4.0</b>	<b>4.0</b>	<b>4.0</b>	<b>5.0</b>	<b>5.0</b>	
	BHP	0.57	0.64	0.70	0.76	0.87	1.00	1.01	1.03	1.19	<b>1.25</b>	<b>1.28</b>	<b>1.33</b>	<b>1.59</b>	<b>1.64</b>	<b>1.68</b>	<b>1.91</b>	
	RPM	582	624	665	705	754	802	827	852	900	<b>930</b>	<b>955</b>	<b>1005</b>	<b>1078</b>	<b>1110</b>	<b>1169</b>	<b>1228</b>	
	URNS OPEN	5.0	4.0	3.0	2.0	4.0	3.0	2.5	2.0	1.0	<b>3.5</b>	<b>3.0</b>	<b>2.0</b>	<b>0.5</b>	<b>0.0</b>	<b>3.0</b>	<b>2.0</b>	
3200	MTR/SHEAVE	2.0	2.0	2.0	1.0	1.0	1.0	1.0	3.0	3.0	3.0	3.0	3.0	5.0	5.0			
	BHP	0.70	0.78	0.86	0.97	1.11	1.13	1.15	1.31	1.38	1.44	1.61	1.69	<b>1.80</b>	<b>2.02</b>			
	RPM	623	664	704	753	801	826	851	899	919	949	978	1036	1086	<b>1137</b>	<b>1196</b>		
	URNS OPEN	4.0	3.0	2.0	4.0	3.0	2.5	2.0	1.0	4.0	3.5	3.0	2.5	1.5	<b>3.5</b>	<b>2.5</b>		
3400	MTR/SHEAVE	2.0	2.0	1.0	1.0	1.0	1.0	3.0	3.0	3.0	3.0	3.0	3.0	5.0	5.0			
	BHP	0.85	0.94	1.07	1.21	1.24	1.26	1.42	1.43	1.50	1.57	1.65	1.71	1.76	<b>2.10</b>	<b>2.35</b>		
	RPM	663	703	752	800	825	849	896	917	947	976	1020	1057	1094	<b>1164</b>	<b>1223</b>		
	URNS OPEN	3.0	2.0	4.0	3.0	2.5	2.0	1.0	4.0	3.5	3.0	2.5	1.8	1.0	<b>3.0</b>	<b>2.0</b>		
3600	MTR/SHEAVE	2.0	1.0	1.0	1.0	1.0	3.0	3.0	3.0	3.0	3.0	3.0	3.0	5.0	5.0			
	BHP	1.01	1.16	1.31	1.34	1.37	1.54	1.55	1.63	1.70	1.78	1.87	2.06	<b>2.15</b>	<b>2.40</b>			
	RPM	702	751	798	823	848	894	915	945	974	1003	1031	1088	<b>1133</b>	<b>1191</b>			
	URNS OPEN	2.0	4.0	3.0	2.5	2.0	1.0	4.0	3.5	3.0	2.5	2.0	1.5	<b>3.5</b>	<b>2.5</b>			
3800	MTR/SHEAVE	1.0	1.0	1.0	1.0	1.0	3.0	3.0	3.0	3.0	3.0	3.0	5.0	5.0				
	BHP	1.23	1.40	1.44	1.48	1.66	1.67	1.75	1.83	1.91	2.00	2.10	<b>2.19</b>	<b>2.44</b>				
	RPM	750	797	821	845	893	913	942	971	1000	1029	1086	<b>1102</b>	<b>1160</b>				
	URNS OPEN	4.0	3.0	2.5	2.0	1.0	4.0	3.5	3.0	2.5	2.0	1.5	<b>4.0</b>	<b>3.0</b>				

07/25/07

**Bold Face Requires Larger 2 HP Motor**

A=Std Static/Std Mtr;B=Low Static/Std. Mtr;C=High Static/Std. Mtr;D=Std Static/Large Mtr;E=High Static/Large Mtr

Units factory shipped with standard static sheave and drive at 2 turns open (3200 cfm @ 0.6 in. ESP). Other speeds require field selection.

ISO/AHRI rating point with standard static sheave and drive at 2 turns open (3200 cfm @ 0.6 in. ESP). Other speeds require field selection.

For applications requiring higher static pressures, contact your local representative.

Performance data does not include drive losses and is based on sea level conditions.

Do not operate in gray region. "na" = information not available at time of printing.

All airflow is rated at lowest Voltage if unit is dual Voltage rated, i.e. 208V for 208-230V units.

For wet coil performance first calculate the face velocity of the air coil (Face Velocity [fpm] = Airflow [cfm] / Face Area [sq ft]).

Then for velocities of 200 fpm reduce the static capability by 0.03 in. wg, 300 fpm by 0.08 in. wg, and 400 fpm by 0.12in. wg.



# Horizontal YL120 - Blower Performance Data

## Belt Drive

Airflow in CFM with dry coil and clean air filter.

Rated CFM		External Static Pressure (in. w.g.)															
		0.0	0.1	0.2	0.3	0.4	0.5	0.6	0.7	0.8	0.9	1.0	1.2	1.4	1.6	1.8	2.0
3000	MTR/SHEAVE					2.0	2.0	2.0	2.0	1.0	1.0	1.0	1.0	1.0	1.0	3.0	3.0
	BHP					0.80	0.88	0.96	1.07	1.09	1.11	1.13	1.28	1.36	1.48	1.67	1.86
	RPM					707	748	789	830	857	882	907	931	956	1032	1115	1198
	TURNS OPEN					5.0	4.0	3.0	2.0	5.0	4.5	4.0	3.5	2.5	1.0	4.5	3.5
3200	MTR/SHEAVE				2.0	2.0	2.0	2.0	1.0	1.0	1.0	1.0	1.0	1.0	3.0	3.0	3.0
	BHP				0.90	0.99	1.09	1.16	1.22	1.25	1.27	1.34	1.49	1.63	1.77	1.98	2.08
	RPM				707	747	788	830	855	880	905	930	955	1031	1107	1166	1210
	TURNS OPEN				5.0	4.0	3.0	2.0	5.0	4.5	4.0	3.5	2.5	1.0	4.0	3.0	2.5
3400	MTR/SHEAVE			2.0	2.0	2.0	2.0	1.0	1.0	1.0	1.0	1.0	1.0	3.0	3.0	3.0	3.0
	BHP			0.99	1.09	1.20	1.19	1.35	1.38	1.41	1.44	1.47	1.55	1.76	2.06	2.15	2.24
	RPM			706	747	787	829	854	879	904	929	954	1004	1070	1137	1180	1224
	TURNS OPEN			5.0	4.0	3.0	2.0	5.0	4.5	4.0	3.5	3.0	2.0	4.5	3.5	2.5	2.0
3600	MTR/SHEAVE		2.0	2.0	2.0	2.0	1.0	1.0	1.0	1.0	1.0	1.0	3.0	3.0	3.0	3.0	3.0
	BHP		1.05	1.18	1.30	1.32	1.47	1.51	1.54	1.58	1.61	1.85	1.90	2.12	2.22	2.32	2.51
	RPM		706	746	787	828	853	878	903	928	953	1001	1044	1103	1134	1184	1233
	TURNS OPEN		5.0	4.0	3.0	2.0	5.0	4.5	4.0	3.5	3.0	2.0	5.0	4.0	3.5	2.5	1.5
3800	MTR/SHEAVE	2.0	2.0	2.0	2.0	1.0	1.0	1.0	1.0	1.0	1.0	1.0	3.0	3.0	3.0	3.0	3.0
	BHP	1.11	1.25	1.39	1.53	1.59	1.63	1.67	1.71	1.75	1.99	2.08	2.16	2.27	2.37	2.64	2.75
	RPM	705	756	786	827	853	878	902	927	951	999	1037	1075	1118	1161	1219	1255
	TURNS OPEN	5.0	4.0	3.0	2.0	5.0	4.5	4.0	3.5	3.0	2.0	1.0	4.5	3.5	3.0	2.0	1.5
4000	MTR/SHEAVE	2.0	2.0	2.0	1.0	1.0	1.0	1.0	1.0	1.0	1.0	3.0	3.0	3.0	3.0	3.0	3.0
	BHP	1.31	1.46	1.61	1.68	1.74	1.79	1.84	1.89	2.13	2.17	2.20	2.43	2.68	2.76	2.84	2.94
	RPM	745	786	826	852	877	901	926	950	998	1023	1047	1100	1157	1188	1231	1275
	TURNS OPEN	4.0	3.0	2.0	5.0	4.5	4.0	3.5	3.0	2.0	1.0	5.0	4.0	3.0	2.5	1.5	1.0
4200	MTR/SHEAVE	2.0	2.0	1.0	1.0	1.0	1.0	1.0	1.0	1.0	3.0	3.0	3.0	3.0	3.0	3.0	
	BHP	1.52	1.69	1.85	1.88	1.90	1.96	2.02	2.26	2.30	2.34	2.57	2.84	2.91	2.97	3.28	
	RPM	785	825	851	876	900	925	949	997	1018	1039	1098	1155	1184	1214	1270	
	TURNS OPEN	3.0	2.0	5.0	4.5	4.0	3.5	3.0	2.0	1.0	5.0	4.5	3.5	2.5	2.0	1.0	

07/23/07

A=Std Static/Std Mtr;B=Low Static/Std. Mtr;C=High Static/Std. Mtr;D=Std Static/Large Mtr;E=High Static/Large Mtr

Units factory shipped with standard static sheave and drive at 3.0 turns open (3600 cfm @ 0.9 in. ESP). Other speeds require field selection.

ISO/AHRI rating point with standard static sheave and drive at 2.0 turns open (3600 cfm @ 1.0 in. ESP). Other speeds require field selection.

For applications requiring higher static pressures, contact your local representative.

Performance data does not include drive losses and is based on sea level conditions.

Do not operate in gray region. "na" = information not available at time of printing.

All airflow is rated at lowest Voltage if unit is dual Voltage rated, i.e. 208V for 208-230V units.

For wet coil performance first calculate the face velocity of the air coil (Face Velocity [fpm] = Airflow [cfm] / Face Area [sq ft]).

Then for velocities of 200 fpm reduce the static capability by 0.03 in. wg, 300 fpm by 0.08 in. wg, and 400 fpm by 0.12in. wg.

# Vertical YL080 - Blower Performance Data

## Belt Drive

Airflow in CFM with dry coil and clean air filter.

Rated CFM		External Static Pressure (in. w.g.)																
		0.0	0.1	0.2	0.3	0.4	0.5	0.6	0.7	0.8	0.9	1.0	1.1	1.2	1.3	1.4	1.5	
2200	MTR/SHEAVE	2.0	2.0	2.0	2.0	1.0	1.0	1.0	1.0	1.0	1.0	1.0	1.0	5.0	5.0	5.0	5.0	5.0
	BHP	0.29	0.33	0.38	0.37	0.45	0.47	0.50	0.54	0.58	0.64	0.69	0.71	0.73	0.84	0.95	1.05	
	RPM	437	478	518	539	586	617	647	677	707	736	765	775	809	843	876	909	
	URNS OPEN	4.0	3.0	2.0	1.5	5.0	4.5	4.0	3.5	3.0	2.5	2.0	3.5	3.0	2.5	2.0	1.5	
2400	MTR/SHEAVE	2.0	2.0	2.0	1.0	1.0	1.0	1.0	1.0	1.0	1.0	5.0	5.0	5.0	5.0	5.0	5.0	
	BHP	0.38	0.44	0.43	0.52	0.56	0.59	0.63	0.68	0.73	0.78	0.81	0.83	0.94	1.05	1.13	1.20	
	RPM	477	517	538	585	615	645	675	704	734	763	774	807	841	874	907	940	
	URNS OPEN	3.0	2.0	1.5	5.0	4.5	4.0	3.5	3.0	2.5	2.0	3.5	3.0	2.5	2.0	1.5	1.0	
2600	MTR/SHEAVE	2.0	2.0	1.0	1.0	1.0	1.0	1.0	1.0	5.0	5.0	5.0	5.0	5.0	5.0	5.0		
	BHP	0.49	0.50	0.59	0.63	0.67	0.72	0.77	0.83	0.89	0.91	0.94	1.05	1.17	1.24	1.32		
	RPM	516	537	584	614	643	673	702	732	761	772	806	839	871	905	938		
	URNS OPEN	2.0	1.5	5.0	4.5	4.0	3.5	3.0	2.5	2.0	3.5	3.0	2.5	2.0	1.5	1.0		
2800	MTR/SHEAVE	2.0	1.0	1.0	1.0	1.0	1.0	1.0	5.0	5.0	5.0	5.0	5.0	5.0	5.0			
	BHP	0.56	0.66	0.71	0.75	0.81	0.86	0.92	0.99	1.02	1.05	1.17	1.29	1.37	1.44			
	RPM	536	582	612	642	671	700	729	758	770	804	837	869	903	936			
	URNS OPEN	1.5	5.0	4.5	4.0	3.5	3.0	2.5	2.0	3.5	3.0	2.5	2.0	1.5	1.0			
3000	MTR/SHEAVE	1.0	1.0	1.0	1.0	1.0	1.0	5.0	5.0	5.0	5.0	5.0	5.0					
	BHP	0.72	0.78	0.83	0.89	0.95	1.02	1.09	1.12	1.16	1.29	1.41	1.49	1.57				
	RPM	581	611	640	669	698	727	756	768	802	835	867	900	933				
	URNS OPEN	5.0	4.5	4.0	3.5	3.0	2.5	2.0	3.5	3.0	2.5	2.0	1.5	1.0				
3200	MTR/SHEAVE	1.0	1.0	1.0	1.0	1.0	1.0	5.0	5.0	5.0	5.0	5.0	5.0					
	BHP	0.83	0.90	0.97	1.03	1.11	1.18	1.14	1.27	1.40	1.53	1.61	1.70					
	RPM	610	639	668	697	726	754	767	800	833	865	898	930					
	URNS OPEN	4.5	4.0	3.5	3.0	2.5	2.0	3.5	3.0	2.5	2.0	1.5	1.0					
3400	MTR/SHEAVE	1.0	1.0	1.0	1.0	5.0	5.0	5.0	5.0	5.0	5.0	5.0						
	BHP	0.97	1.04	1.11	1.19	1.23	1.30	1.37	1.51	1.64	1.73	1.82						
	RPM	637	666	695	725	731	765	798	830	862	895	927						
	URNS OPEN	4.0	3.5	3.0	2.5	4.0	3.5	3.0	2.5	2.0	1.5	1.0						

07/25/07

**Bold Face Requires 1.5 HP Motor**

A=Std Static/Std Mtr;B=Low Static/Std. Mtr;C=High Static/Std. Mtr;D=Std Static/Large Mtr;E=High Static/Large Mtr

Units factory shipped with standard static sheave and drive at 3 turns open (2600 cfm @ 0.6 in. ESP). Other speeds require field selection.

ISO/AHRI rating point with standard static sheave and drive at 3 turns open (2600 cfm @ 0.6 in. ESP). Other speeds require field selection.

For applications requiring higher static pressures, contact your local representative.

Performance data does not include drive losses and is based on sea level conditions.

Do not operate in gray region. "na" = information not available at time of printing.

All airflow is rated at lowest Voltage if unit is dual Voltage rated, i.e. 208V for 208-230V units.

For wet coil performance first calculate the face velocity of the air coil (Face Velocity [fpm] = Airflow [cfm] / Face Area [sq ft]).

Then for velocities of 200 fpm reduce the static capability by 0.03 in. wg, 300 fpm by 0.08 in. wg, and 400 fpm by 0.12in. wg.

# Vertical YL095 - Blower Performance Data

## Belt Drive

Airflow in CFM with dry coil and clean air filter.

Rated CFM	External Static Pressure (in. w.g.)																
	0.0	0.1	0.2	0.3	0.4	0.5	0.6	0.7	0.8	0.9	1.0	1.2	1.4	1.6	1.8	2.0	
2600	MTR/SHEAVE				1.0	1.0	1.0	1.0	1.0	1.0	1.0	1.0	4.0	4.0			
	BHP				0.61	0.64	0.66	0.68	0.76	0.81	0.87	0.89	0.94	1.05			
	RPM				581	601	621	663	703	739	774	784	827	867			
	TURNS OPEN				5.0	4.5	4.0	3.0	2.0	1.5	1.0	0.0	2.0	1.0			
2800	MTR/SHEAVE			1.0	1.0	1.0	1.0	1.0	1.0	1.0	1.0	4.0	4.0	4.0			
	BHP				0.65	0.66	0.68	0.75	0.86	0.87	0.88	1.02	1.05	1.14	1.23		
	RPM				580	600	621	662	701	722	742	782	805	855	905		
	TURNS OPEN				5.0	4.5	4.0	3.0	2.0	1.5	1.0	0.0	2.5	1.5	0.0		
3000	MTR/SHEAVE		1.0	1.0	1.0	1.0	1.0	1.0	1.0	1.0	3.0	3.0	3.0	3.0	3.0	5.0	5.0
	BHP			0.72	0.73	0.74	0.84	0.96	0.98	1.13	1.14	1.17	1.23	1.36	1.48	1.59	1.69
	RPM			579	600	620	660	700	721	741	780	797	813	845	890	940	991
	TURNS OPEN			5.0	4.5	4.0	3.0	2.0	1.5	1.0	0.0	3.0	2.5	2.0	1.0	0.0	3.0
3200	MTR/SHEAVE	1.0	1.0	1.0	1.0	1.0	1.0	1.0	1.0	3.0	3.0	3.0	3.0	3.0	5.0	5.0	5.0
	BHP	0.79	0.80	0.82	0.93	1.06	1.08	1.10	1.25	1.26	1.31	1.36	1.49	1.62	1.67	1.85	2.03
	RPM	578	599	619	659	699	719	739	778	795	819	843	890	937	942	967	991
	TURNS OPEN	5.0	4.5	4.0	3.0	2.0	1.5	1.0	0.0	3.0	2.5	2.0	1.0	0.0	3.0	2.5	2.0
3400	MTR/SHEAVE	1.0	1.0	1.0	1.0	1.0	1.0	1.0	3.0	3.0	3.0	3.0	3.0	5.0	5.0	5.0	5.0
	BHP	0.84	0.89	1.01	1.15	1.17	1.20	1.35	1.36	1.42	1.48	1.52	1.61	1.82	1.90	1.99	2.03
	RPM	597	619	658	697	718	738	776	794	818	841	857	888	940	963	986	1034
	TURNS OPEN	4.5	4.0	3.0	2.0	1.5	1.0	0.0	3.0	2.5	2.0	1.5	1.0	3.0	2.5	2.0	1.0
3600	MTR/SHEAVE	1.0	1.0	1.0	1.0	1.0	1.0	3.0	3.0	3.0	3.0	3.0	5.0	5.0	5.0	5.0	5.0
	BHP	0.97	1.09	1.23	1.26	1.29	1.45	1.47	1.53	1.60	1.67	1.74	1.95	2.05	2.14	2.19	2.41
	RPM	618	657	696	716	736	775	792	815	838	862	885	937	960	983	1031	1077
	TURNS OPEN	4.0	3.0	2.0	1.5	1.0	0.0	3.0	2.5	2.0	1.5	1.0	3.0	2.5	2.0	1.0	0.0
3800	MTR/SHEAVE	1.0	1.0	1.0	1.0	1.0	3.0	3.0	3.0	3.0	3.0	5.0	5.0	5.0	5.0	5.0	
	BHP	1.17	1.32	1.35	1.38	1.55	1.57	1.64	1.71	1.78	1.86	2.09	2.18	2.28	2.34	2.57	
	RPM	656	695	715	735	773	790	814	837	860	883	935	958	981	1029	1074	
	TURNS OPEN	3.0	2.0	1.5	1.0	0.0	3.0	2.5	2.0	1.5	1.0	3.0	2.5	2.0	1.0	0.0	

7/25/07

**Bold Face Requires Larger 2 HP Motor**

A=Std Static/Std Mtr;B=Low Static/Std. Mtr;C=High Static/Std. Mtr;D=Std Static/Large Mtr;E=High Static/Large Mtr

Units factory shipped with standard static sheave and drive at 2 turns open (2800 cfm @ 0.6 in. ESP). Other speeds require field selection.

ISO/AHRI rating point with standard static sheave and drive at 1 turns open (2800 cfm @ 0.7 in. ESP). Other speeds require field selection.

For applications requiring higher static pressures, contact your local representative.

Performance data does not include drive losses and is based on sea level conditions.

Do not operate in gray region. "na" = information not available at time of printing.

All airflow is rated at lowest Voltage if unit is dual Voltage rated, i.e. 208V for 208-230V units.

For wet coil performance first calculate the face velocity of the air coil (Face Velocity [fpm] = Airflow [cfm] / Face Area [sq ft]).

Then for velocities of 200 fpm reduce the static capability by 0.03 in. wg, 300 fpm by 0.08 in. wg, and 400 fpm by 0.12in. wg.

# Vertical YL120 - Blower Performance Data

## Belt Drive

Airflow in CFM with dry coil and clean air filter.

Rated CFM		External Static Pressure (in. w.g.)															
		0.0	0.1	0.2	0.3	0.4	0.5	0.6	0.7	0.8	0.9	1.0	1.2	1.4	1.6	1.8	2.0
3200	MTR/SHEAVE	2.0	2.0	2.0	2.0	2.0	1.0	1.0	1.0	1.0	1.0	1.0	1.0	3.0	3.0	3.0	
	BHP	0.50	0.51	0.59	0.68	0.68	0.79	0.92	0.92	0.92	1.08	1.16	1.30	1.31	1.41	1.59	
	RPM	418	438	480	521	541	582	623	644	665	705	732	787	826	867	932	
	TURNS OPEN	4.5	4.0	<b>B</b> 3.0	2.0	1.0	5.0	4.0	3.5	3.0	2.0	1.5	0.5	2.0	1.0	0.0	
3400	MTR/SHEAVE	2.0	2.0	<b>B</b> 2.0	2.0	1.0	1.0	1.0	1.0	1.0	1.0	3.0	3.0	3.0			
	BHP	0.58	0.67	0.77	0.78	0.90	1.04	1.05	1.07	1.16	1.26	1.28	1.37	1.47	1.65		
	RPM	438	480	520	541	582	622	643	664	694	724	746	795	843	888		
	TURNS OPEN	4.0	3.0	2.0	1.0	5.0	4.0	3.5	3.0	2.5	1.5	1.0	3.0	1.5	0.5		
3600	MTR/SHEAVE	2.0	2.0	2.0	1.0	1.0	1.0	1.0	1.0	1.0	3.0	3.0	3.0	3.0			
	BHP	0.74	0.86	0.88	1.00	1.02	1.17	1.20	1.22	1.24	1.44	1.47	1.52	1.82	1.90		
	RPM	479	519	540	581	602	643	663	684	704	745	765	806	866	906		
	TURNS OPEN	3.0	2.0	1.0	5.0	4.5	3.5	<b>A</b> 3.0	2.5	2.0	1.0	3.5	2.5	<b>C</b> 1.0	0.0		
3800	MTR/SHEAVE	2.0	2.0	1.0	1.0	1.0	1.0	1.0	1.0	3.0	3.0	3.0	3.0				
	BHP	0.94	0.96	1.10	1.15	1.24	1.32	1.35	1.38	1.41	1.62	1.66	1.91	2.06			
	RPM	519	539	581	622	642	662	683	704	723	764	784	823	884			
	TURNS OPEN	2.0	1.0	5.0	4.0	3.5	3.0	2.5	2.0	1.5	3.5	3.0	2.0	0.5			
4000	MTR/SHEAVE	2.0	1.0	1.0	1.0	1.0	1.0	1.0	1.0	3.0	3.0	3.0	3.0	5.0	5.0	5.0	
	BHP	1.04	1.20	1.26	1.35	1.44	1.47	1.51	1.55	1.58	1.81	1.86	1.96	2.17	2.25	2.39	2.66
	RPM	539	580	621	641	661	682	703	724	744	783	803	843	893	933	970	1017
	TURNS OPEN	1.0	5.0	4.0	3.5	3.0	2.5	2.0	1.5	1.0	3.0	2.5	1.5	0.0	3.5	<b>D</b> 2.5	1.5
4200	MTR/SHEAVE	1.0	1.0	1.0	1.0	1.0	1.0	1.0	4.0	4.0	4.0	4.0	4.0	5.0	<b>E</b> 5.0	5.0	
	BHP	1.28	1.36	1.45	1.54	1.59	1.63	1.67	1.72	1.95	2.01	2.06	2.19	2.31	2.48	2.75	3.03
	RPM	580	620	641	661	682	702	722	742	782	802	822	863	902	944	991	1037
	TURNS OPEN	5.0	4.0	3.5	3.0	2.5	2.0	1.5	1.0	3.0	2.5	<b>D</b> 2.0	1.0	0.0	3.0	2.0	1.0
4400	MTR/SHEAVE	1.0	1.0	1.0	1.0	1.0	1.0	4.0	4.0	4.0	4.0	4.0	5.0	5.0	5.0		
	BHP	1.46	1.55	1.65	1.70	1.75	1.80	1.85	2.09	2.15	2.21	2.28	2.41	2.54	2.80	3.08	
	RPM	620	640	660	681	701	722	742	781	801	821	841	881	919	965	1012	
	TURNS OPEN	4.0	3.5	3.0	2.5	2.0	1.5	1.0	3.0	2.5	2.0	1.5	0.5	3.5	2.5	1.5	

07/25/07

### Bold Face Requires Larger 3 HP Motor

A=Std Static/Std Mtr;B=Low Static/Std. Mtr;C=High Static/Std. Mtr;D=Std Static/Large Mtr;E=High Static/Large Mtr

Units factory shipped with standard static sheave and drive at 3 turns open (3600 cfm @ 0.6 in. ESP). Other speeds require field selection.

ISO/AHRI rating point with standard static sheave and drive at 1 turns open (3600 cfm @ 0.9 in. ESP). Other speeds require field selection.

For applications requiring higher static pressures, contact your local representative.

Performance data does not include drive losses and is based on sea level conditions.

Do not operate in gray region. "na" = information not available at time of printing.

All airflow is rated at lowest Voltage if unit is dual Voltage rated, i.e. 208V for 208-230V units.

For wet coil performance first calculate the face velocity of the air coil (Face Velocity [fpm] = Airflow [cfm] / Face Area [sq ft]).

Then for velocities of 200 fpm reduce the static capability by 0.03 in. wg, 300 fpm by 0.08 in. wg, and 400 fpm by 0.12 in. wg.

# Vertical YL160 - Blower Performance Data

## Belt Drive

Airflow in CFM with dry coil and clean air filter.

Rated CFM		External Static Pressure (in. w.g.)															
		0.0	0.1	0.2	0.3	0.4	0.5	0.6	0.7	0.8	0.9	1.0	1.1	1.2	1.3	1.4	1.5
4400	MTR/SHEAVE	2.0	2.0	2.0	2.0	1.0	1.0	1.0	1.0	1.0	1.0	1.0	5.0	5.0	5.0	5.0	5.0
	BHP	0.29	0.33	0.38	0.37	0.45	0.47	0.50	0.54	0.58	0.64	0.69	0.71	0.73	0.84	0.95	1.05
	RPM	437	478	518	539	586	617	647	677	707	736	765	775	809	843	876	909
	TURNS OPEN	4.0	3.0	2.0	1.5	5.0	4.5	4.0	3.5	3.0	2.5	2.0	3.5	3.0	2.5	2.0	1.5
4600	MTR/SHEAVE	2.0	2.0	2.0	2.0	1.0	1.0	1.0	1.0	1.0	1.0	1.0	5.0	5.0	5.0	5.0	5.0
	BHP	0.33	0.38	0.41	0.44	0.50	0.53	0.57	0.61	0.66	0.71	0.75	0.77	0.84	0.95	1.04	1.13
	RPM	457	498	528	562	601	631	661	691	720	750	770	791	825	858	892	925
	TURNS OPEN	3.5	2.5	1.5	0.5	4.5	4.0	3.5	3.0	2.5	2.0	1.0	3.0	2.5	2.0	1.5	1.0
4800	MTR/SHEAVE	2.0	2.0	2.0	1.0	1.0	1.0	1.0	1.0	1.0	1.0	5.0	5.0	5.0	5.0	5.0	5.0
	BHP	0.38	0.44	0.43	0.52	0.56	0.59	0.63	0.68	0.73	0.78	0.81	0.83	0.94	1.05	1.13	1.20
	RPM	477	517	538	585	615	645	675	704	734	763	774	807	841	874	907	940
	TURNS OPEN	3.0	2.0	1.5	5.0	4.5	4.0	3.5	3.0	2.5	2.0	3.5	3.0	2.5	2.0	1.5	1.0
5000	MTR/SHEAVE	2.0	2.0	2.0	1.0	1.0	1.0	1.0	1.0	1.0	1.0	5.0	5.0	5.0	5.0	5.0	5.0
	BHP	0.44	0.47	0.51	0.58	0.62	0.66	0.70	0.75	0.81	0.85	0.87	0.94	1.05	1.15	1.22	0.60
	RPM	497	527	561	599	629	659	688	718	747	768	790	823	856	889	923	470
	TURNS OPEN	2.5	1.5	1.0	4.5	4.0	3.5	3.0	2.5	2.0	1.5	3.0	2.5	2.0	1.5	1.0	0.5
5200	MTR/SHEAVE	2.0	2.0	1.0	1.0	1.0	1.0	1.0	1.0	1.0	5.0	5.0	5.0	5.0	5.0	5.0	
	BHP	0.49	0.50	0.59	0.63	0.67	0.72	0.77	0.83	0.89	0.91	0.94	1.05	1.17	1.24	1.32	
	RPM	516	537	584	614	643	673	702	732	761	772	806	839	871	905	938	
	TURNS OPEN	2.0	1.5	5.0	4.5	4.0	3.5	3.0	2.5	2.0	3.5	3.0	2.5	2.0	1.5	1.0	
5400	MTR/SHEAVE	2.0	2.0	1.0	1.0	1.0	1.0	1.0	1.0	1.0	5.0	5.0	5.0	5.0	5.0	5.0	
	BHP	0.53	0.58	0.65	0.69	0.74	0.79	0.85	0.91	0.95	0.98	1.05	1.17	1.27	1.34	0.66	
	RPM	526	560	598	628	657	686	716	745	766	788	821	854	887	920	469	
	TURNS OPEN	1.5	1.0	4.5	4.0	3.5	3.0	2.5	2.0	1.5	3.0	2.5	2.0	1.5	1.0	0.5	
5600	MTR/SHEAVE	2.0	1.0	1.0	1.0	1.0	1.0	1.0	5.0	5.0	5.0	5.0	5.0	5.0			
	BHP	0.56	0.66	0.71	0.75	0.81	0.86	0.92	0.99	1.02	1.05	1.17	1.29	1.37	1.44		
	RPM	536	582	612	642	671	700	729	758	770	804	837	869	903	936		
	TURNS OPEN	1.5	5.0	4.5	4.0	3.5	3.0	2.5	2.0	3.5	3.0	2.5	2.0	1.5	1.0		

7/25/07

### Bold Face Requires Larger 1.5 HP Motor

A=Std Static/Std Mtr;B=Low Static/Std. Mtr;C=High Static/Std. Mtr;D=Std Static/Large Mtr;E=High Static/Large Mtr

Units factory shipped with standard static sheave and drive at 3 turns open (5000 cfm @ 0.6 in. ESP). Other speeds require field selection.

ISO/AHRI rating point with standard static sheave and drive at 2.0 turns open (5000 cfm @ 0.7 in. ESP). Other speeds require field selection.

For applications requiring higher static pressures, contact your local representative.

Performance data does not include drive losses and is based on sea level conditions.

Do not operate in gray region. "na" = information not available at time of printing.

All airflow is rated at lowest Voltage if unit is dual Voltage rated, i.e. 208V for 208-230V units.

For wet coil performance first calculate the face velocity of the air coil (Face Velocity [fpm] = Airflow [cfm] / Face Area [sq ft]).

Then for velocities of 200 fpm reduce the static capability by 0.03 in. wg, 300 fpm by 0.08 in. wg, and 400 fpm by 0.12 in. wg.

BHP is given for each blower. Multiply BHP x 2 for unit BHP.

# Vertical YL180 - Blower Performance Data

## Belt Drive

Airflow in CFM with dry coil and clean air filter.

Rated CFM		External Static Pressure (in. w.g.)															
		0.0	0.1	0.2	0.3	0.4	0.5	0.6	0.7	0.8	0.9	1.0	1.2	1.4	1.6	1.8	2.0
5200	MTR/SHEAVE				1.0	1.0	1.0	1.0	1.0	1.0	1.0	1.0	<b>4.0</b>	<b>4.0</b>			
	BHP				0.61	0.64	0.66	0.68	0.76	0.81	0.87	0.89	<b>0.94</b>	<b>1.05</b>			
	RPM				581	601	621	663	703	739	774	784	<b>827</b>	<b>867</b>			
	TURNS OPEN				5.0	4.5	4.0	3.0	2.0	1.5	1.0	0.5	<b>2.0</b>	<b>1.0</b>			
5400	MTR/SHEAVE				1.0	1.0	1.0	1.0	1.0	1.0	1.0	1.0	<b>4.0</b>	<b>4.0</b>			
	BHP				0.64	0.66	0.71	0.77	0.82	0.85	0.94	0.97	<b>1.04</b>	<b>1.14</b>			
	RPM				591	611	642	682	712	740	778	795	<b>841</b>	<b>886</b>			
	TURNS OPEN				4.5	4.0	3.5	2.5	1.5	1.0	0.5	0.0	<b>1.5</b>	<b>0.5</b>			
5600	MTR/SHEAVE			1.0	1.0	1.0	1.0	1.0	1.0	1.0	1.0	<b>4.0</b>	<b>4.0</b>	<b>4.0</b>			
	BHP			0.65	0.66	0.68	0.75	0.86	0.87	0.88	1.02	<b>1.05</b>	<b>1.14</b>	<b>1.23</b>			
	RPM			580	600	621	662	701	722	742	782	<b>805</b>	<b>855</b>	<b>905</b>			
	TURNS OPEN			5.0	4.5	4.0	3.0	2.0	1.5	1.0	0.0	<b>2.5</b>	<b>1.5</b>	<b>0.0</b>			
5800	MTR/SHEAVE			1.0	1.0	1.0	1.0	1.0	1.0	1.0	1.0	3.0	3.0	3.0	3.0	<b>5.0</b>	<b>5.0</b>
	BHP			0.69	0.70	0.76	0.86	0.92	0.93	1.01	1.08	1.11	1.19	1.30	0.74	<b>0.80</b>	<b>0.85</b>
	RPM			590	610	641	681	711	731	761	790	809	850	898	470	<b>480</b>	<b>496</b>
	TURNS OPEN			4.5	4.0	3.5	2.5	1.5	1.0	0.5	0.0	3.0	2.5	2.0	1.0	<b>3.0</b>	<b>2.5</b>
6000	MTR/SHEAVE		1.0	1.0	1.0	1.0	1.0	1.0	1.0	1.0	3.0	3.0	3.0	3.0	3.0	<b>5.0</b>	<b>5.0</b>
	BHP		0.72	0.73	0.74	0.84	0.96	0.98	0.99	1.13	1.14	1.17	1.23	1.36	1.48	<b>1.59</b>	<b>1.69</b>
	RPM		579	600	620	660	700	721	741	780	797	813	845	890	940	<b>960</b>	<b>991</b>
	TURNS OPEN		5.0	4.5	4.0	3.0	2.0	1.5	1.0	0.0	3.0	2.5	2.0	1.0	0.0	<b>3.0</b>	<b>2.5</b>
6200	MTR/SHEAVE		1.0	1.0	1.0	1.0	1.0	1.0	1.0	1.0	3.0	3.0	3.0	3.0	<b>5.0</b>	<b>5.0</b>	<b>5.0</b>
	BHP		0.76	0.77	0.84	0.95	1.02	1.04	1.12	1.20	1.23	1.27	1.36	1.49	<b>1.58</b>	<b>1.72</b>	<b>1.86</b>
	RPM		589	609	640	680	710	730	760	788	808	828	868	914	<b>941</b>	<b>963</b>	<b>991</b>
	TURNS OPEN		4.5	4.0	3.5	2.5	1.5	1.0	0.5	0.0	2.5	2.0	1.5	0.5	<b>3.5</b>	<b>2.5</b>	<b>2.0</b>
6400	MTR/SHEAVE	1.0	1.0	1.0	1.0	1.0	1.0	1.0	1.0	3.0	3.0	3.0	3.0	3.0	<b>5.0</b>	<b>5.0</b>	<b>5.0</b>
	BHP	0.79	0.80	0.82	0.93	1.06	1.08	1.10	1.25	1.26	1.31	1.36	1.49	1.62	<b>1.67</b>	<b>1.85</b>	<b>2.03</b>
	RPM	578	599	619	659	699	719	739	778	795	819	843	890	937	<b>942</b>	<b>967</b>	<b>991</b>
	TURNS OPEN	5.0	4.5	4.0	3.0	2.0	1.5	1.0	0.0	3.0	2.5	2.0	1.0	0.0	<b>3.0</b>	<b>2.5</b>	<b>2.0</b>

7/25/07

### Bold Face Requires Larger 2.0 HP Motor

A=Std Static/Std Mtr;B=Low Static/Std. Mtr;C=High Static/Std. Mtr;D=Std Static/Large Mtr;E=High Static/Large Mtr

Units factory shipped with standard static sheave and drive at 3 turns open (5600 cfm @ 0.6 in. ESP). Other speeds require field selection.

ISO/AHRI rating point with standard static sheave and drive at 1.5 turns open (5600 cfm @ 0.7 in. ESP). Other speeds require field selection.

For applications requiring higher static pressures, contact your local representative.

Performance data does not include drive losses and is based on sea level conditions.

Do not operate in gray region. "na" = information not available at time of printing.

All airflow is rated at lowest Voltage if unit is dual Voltage rated, i.e. 208V for 208-230V units.

For wet coil performance first calculate the face velocity of the air coil (Face Velocity [fpm] = Airflow [cfm] / Face Area [sq ft]).

Then for velocities of 200 fpm reduce the static capability by 0.03 in. wg, 300 fpm by 0.08 in. wg, and 400 fpm by 0.12 in. wg.

BHP is given for each blower. Multiply BHP x 2 for unit BHP.

# Vertical YL240 - Blower Performance Data

## Belt Drive

Airflow in CFM with dry coil and clean air filter.

Rated CFM		External Static Pressure (in. w.g.)															
		0.0	0.1	0.2	0.3	0.4	0.5	0.6	0.7	0.8	0.9	1.0	1.2	1.4	1.6	1.8	2.0
6400	MTR/SHEAVE	2.0	2.0	2.0	2.0	2.0	1.0	1.0	1.0	1.0	1.0	1.0	1.0	3.0	3.0	3.0	
	BHP	0.50	0.51	0.59	0.68	0.68	0.79	0.92	0.92	0.92	1.08	1.16	1.30	1.31	1.41	1.59	
	RPM	438	438	480	521	541	582	623	644	665	705	732	787	826	867	932	
	TURNS OPEN	4.5	4.0	<b>B</b> 3.0	2.0	1.0	5.0	4.0	3.5	3.0	2.0	1.5	0.5	2.0	1.0	0.0	
6800	MTR/SHEAVE	2.0	2.0	2.0	2.0	1.0	1.0	1.0	1.0	1.0	1.0	1.0	3.0	3.0	3.0		
	BHP	0.58	0.67	0.77	0.78	0.90	1.04	1.05	1.07	1.16	1.26	1.28	1.37	1.47	1.65		
	RPM	438	480	520	541	582	622	643	664	694	724	746	795	843	888		
	TURNS OPEN	4.0	3.0	2.0	1.0	5.0	4.0	3.5	3.0	2.5	1.5	1.0	3.0	1.5	0.5		
7200	MTR/SHEAVE	2.0	2.0	2.0	1.0	1.0	1.0	1.0	1.0	1.0	1.0	3.0	3.0	3.0	3.0		
	BHP	0.74	0.86	0.88	1.00	1.02	1.17	1.20	1.22	1.24	1.44	1.47	1.52	1.82	1.90		
	RPM	479	519	540	581	602	643	663	684	704	745	765	806	866	906		
	TURNS OPEN	3.0	2.0	1.0	5.0	4.5	3.5	3.0	2.5	2.0	1.0	3.5	2.5	<b>C</b> 1.0	0.0		
7600	MTR/SHEAVE	2.0	2.0	1.0	1.0	1.0	1.0	1.0	1.0	3.0	3.0	3.0	3.0				
	BHP	0.94	0.96	1.10	1.15	1.24	1.32	1.35	1.38	1.41	1.62	1.66	1.91	2.06			
	RPM	519	539	581	622	642	662	683	704	723	764	784	823	884			
	TURNS OPEN	2.0	1.0	5.0	4.0	3.5	3.0	2.5	2.0	1.5	3.5	3.0	2.0	0.5			
8000	MTR/SHEAVE	2.0	1.0	1.0	1.0	1.0	1.0	1.0	1.0	3.0	3.0	3.0	3.0	5.0	5.0	5.0	
	BHP	1.04	1.20	1.26	1.35	1.44	1.47	1.51	1.55	1.58	1.81	1.86	1.96	2.17	2.25	2.39	2.66
	RPM	539	580	621	641	661	682	703	724	744	783	803	843	893	933	970	1017
	TURNS OPEN	1.0	5.0	4.0	3.5	3.0	2.5	2.0	1.5	1.0	3.0	2.5	1.5	0.0	3.5	2.5	1.5
8400	MTR/SHEAVE	1.0	1.0	1.0	1.0	1.0	1.0	1.0	4.0	4.0	4.0	4.0	4.0	5.0	5.0	5.0	
	BHP	1.28	1.36	1.45	1.54	1.59	1.63	1.67	1.72	1.95	2.01	2.06	2.19	2.31	2.48	2.75	3.03
	RPM	580	620	641	661	682	702	722	742	782	802	822	863	902	944	991	1037
	TURNS OPEN	5.0	4.0	3.5	3.0	2.5	2.0	1.5	1.0	3.0	2.5	2.0	1.0	0.0	3.0	2.0	1.0
8800	MTR/SHEAVE	1.0	1.0	1.0	1.0	1.0	1.0	4.0	4.0	4.0	4.0	4.0	5.0	5.0	5.0		
	BHP	1.46	1.55	1.65	1.70	1.75	1.80	1.85	2.09	2.15	2.21	2.28	2.41	2.54	2.80	3.08	
	RPM	620	640	660	681	701	722	742	781	801	821	841	881	919	965	1012	
	TURNS OPEN	4.0	3.5	3.0	2.5	2.0	1.5	1.0	3.0	2.5	2.0	1.5	0.5	3.5	2.5	1.5	

7/25/07

### Bold Face Requires Larger 3.0 HP Motor

A=Std Static/Std Mtr;B=Low Static/Std. Mtr;C=High Static/Std. Mtr;D=Std Static/Large Mtr;E=High Static/Large Mtr

Units factory shipped with standard static sheave and drive at 2.5 turns open (7600 cfm @ 0.6 in. ESP). Other speeds require field selection.

ISO/AHRI rating point with standard static sheave and drive at 2 turns open (7600 cfm @ 0.7 in. ESP). Other speeds require field selection.

For applications requiring higher static pressures, contact your local representative.

Performance data does not include drive losses and is based on sea level conditions.

Do not operate in gray region. "na" = information not available at time of printing.

All airflow is rated at lowest Voltage if unit is dual Voltage rated, i.e. 208V for 208-230V units.

For wet coil performance first calculate the face velocity of the air coil (Face Velocity [fpm] = Airflow [cfm] / Face Area [sq ft]).

Then for velocities of 200 fpm reduce the static capability by 0.03 in. wg, 300 fpm by 0.08 in. wg, and 400 fpm by 0.12 in. wg.

BHP is given for each blower. Multiply BHP x 2 for unit BHP.

# Vertical YL300 - Blower Performance Data

## Belt Drive

Airflow in CFM with dry coil and clean air filter.

Rated CFM		External Static Pressure (in. w.g.)															
		0.0	0.1	0.2	0.3	0.4	0.5	0.6	0.7	0.8	0.9	1.0	1.2	1.4	1.6	1.8	2.0
8400	MTR/SHEAVE				2.0	2.0	2.0	2.0	2.0	1.0	1.0	1.0	1.0	1.0	1.0	3.0	
	BHP				1.46	1.49	1.77	1.94	2.11	2.29	2.32	2.39	2.65	2.72	2.80	2.36	
	RPM				677	696	745	778	810	841	858	878	912	932	951	994	
	TURNS OPEN				5.0	4.0	3.0	2.0	1.0	4.0	3.5	3.0	2.0	1.5	1.0	4.5	
8800	MTR/SHEAVE			2.0	2.0	2.0	2.0	1.0	1.0	1.0	1.0	1.0	1.0	3.0	3.0		
	BHP			1.55	1.70	1.86	2.03	2.21	2.39	2.42	2.50	2.75	2.83	2.91	2.63	2.61	
	RPM			674	708	742	774	806	837	853	873	907	926	945	981	1010	
	TURNS OPEN			5.0	4.0	3.0	2.0	1.0	4.0	3.5	3.0	2.0	1.5	1.0	4.5	4.0	
9200	MTR/SHEAVE		2.0	2.0	2.0	2.0	1.0	1.0	1.0	1.0	1.0	1.0	3.0	3.0	3.0		
	BHP		1.63	1.79	1.96	2.13	2.31	2.49	2.52	2.60	2.85	2.93	3.01	2.87	2.87	2.86	
	RPM		671	705	738	771	802	833	849	869	903	922	940	969	997	1025	
	TURNS OPEN		5.0	4.0	3.0	2.0	1.0	4.0	3.5	3.0	2.0	1.5	1.0	4.5	4.0	3.5	
9600	MTR/SHEAVE	2.0	2.0	2.0	2.0	1.0	1.0	1.0	1.0	1.0	1.0	3.0	3.0	3.0			
	BHP	1.72	1.88	2.04	2.22	2.40	2.58	2.62	2.70	2.95	3.03	3.11	3.09	3.10	3.11		
	RPM	668	702	735	767	799	829	845	864	898	917	935	959	985	1012		
	TURNS OPEN	5.0	4.0	3.0	2.0	1.0	4.0	3.5	3.0	2.0	1.5	1.0	4.5	4.0	3.5		
10000	MTR/SHEAVE	2.0	2.0	2.0	2.0	1.0	1.0	1.0	1.0	1.0	3.0	3.0	3.0				
	BHP	1.96	2.13	2.31	2.49	2.68	2.71	2.79	3.05	3.13	3.21	3.29	3.31	3.33			
	RPM	699	732	764	795	825	841	860	894	912	931	949	975	1001			
	TURNS OPEN	4.0	3.0	2.0	1.0	4.0	3.5	3.0	2.0	1.5	1.0	4.5	4.0	3.5			
10400	MTR/SHEAVE	2.0	2.0	2.0	1.0	1.0	1.0	1.0	1.0	3.0	3.0	3.0	3.0				
	BHP	2.21	2.39	2.58	2.77	2.81	2.89	3.13	3.22	3.31	3.39	3.51	3.54	3.56			
	RPM	729	761	792	821	837	856	890	908	926	944	965	990	1016			
	TURNS OPEN	3.0	2.0	1.0	4.0	3.5	3.0	2.0	1.5	1.0	4.5	4.0	3.5	3.0			
10800	MTR/SHEAVE	2.0	2.0	1.0	1.0	1.0	1.0	1.0	3.0	3.0	3.0	3.0					
	BHP	2.48	2.66	2.85	2.90	2.98	3.23	3.32	3.40	3.48	3.61	3.73	3.76				
	RPM	758	788	818	833	852	885	904	922	939	960	980	1005				
	TURNS OPEN	2.0	1.0	4.0	3.5	3.0	2.0	1.5	1.0	4.5	4.0	3.5	3.0				

7/25/07

A=Std Static/Std Mtr;B=Low Static/Std. Mtr;C=High Static/Std. Mtr;D=Std Static/Large Mtr;E=High Static/Large Mtr

Units factory shipped with standard static sheave and drive at 3.0 turns open (9500 cfm @ 0.7 in. ESP). Other speeds require field selection.

ISO/AHRI rating point with standard static sheave and drive at 3.0 turns open (9500 cfm @ 0.7 in. ESP). Other speeds require field selection.

For applications requiring higher static pressures, contact your local representative.

Performance data does not include drive losses and is based on sea level conditions.

Do not operate in gray region. "na" = information not available at time of printing.

All airflow is rated at lowest Voltage if unit is dual Voltage rated, i.e. 208V for 208-230V units.

For wet coil performance first calculate the face velocity of the air coil (Face Velocity [fpm] = Airflow [cfm] / Face Area [sq ft]).

Then for velocities of 200 fpm reduce the static capability by 0.03 in. wg, 300 fpm by 0.08 in. wg, and 400 fpm by 0.12 in. wg.

BHP is given for each blower. Multiply BHP x 2 for unit BHP.



## Selection Example

To achieve optimal performance, proper selection of each heat pump is essential. A building load program should be used to determine the heating and cooling load of each zone. A computer software selection program can then be used to develop an accurate and complete heat pump schedule. Software can be obtained from your local sales representative.

While software is the easiest and most accurate method to size and select equipment, however, selection can still be accomplished manually using this manual and the following selection procedure. Sizing so that the actual sensible capacity of the equipment will satisfy the sensible capacity of the zone is the recommended method for best results.

### Boiler/Tower Application

Typical boiler/tower application will result in entering water temperatures of 60-90°F with 70°F for heating and 90°F for cooling. Water to refrigerant insulation option would not be required. Flow rates are 2.5 to 3 gpm per ton with 2.5 gpm per ton often representing an economical design point.

### Geothermal Application

Typical geothermal application can result in a wide entering water temperature range of 30-100°F. Typically minimum heating entering water temperatures can range from 30 to 50°F depending upon loop type and geographical location. Cooling performance should be calculated using a maximum loop temperature of 100°F in most loop applications. Water flow is typically 2.5 to 3 gpm per ton with 3 gpm per ton recommended with the more extreme loop temperatures. **PLEASE NOTE THAT WATER COIL INSULATION OPTION SHOULD BE SELECTED WHEN ENTERING WATER TEMPERATURES ARE EXPECTED TO BE BELOW 45-50°F.**

## Geothermal Selection Example

### Capacity Tables

YL080-300

### Selection Procedure

#### I. Determine Unit Requirements

##### Zone Design Conditions:

Total Cooling Load.....	82,000 BTUH
Sensible Cooling Load .....	63,800 BTUH
Total Heating Load .....	91,000 BTUH
Required Airflow .....	2700 cfm
Required External Static.....	0.60 in wg

##### System Design Conditions:

Entering water conditions will vary depending upon system type. A boiler/tower system will typically have different entering water conditions than a closed loop system. Refer to the performance data tables for maximum and minimum entering water temperatures. Contact your technical representative if you have questions regarding a specific application. The following design example is for a commercial ground source vertical closed loop.

#### Unit Selection Parameters:

Ent Water Temperature (EWT) – Max Clg.....	95°F
Ent Water Temperature (EWT) – Min Htg.....	45°F
Ent Air Temperature Dry-Bulb (Summer).....	75°F
Ent Air Temperature Wet-Bulb (Summer) .....	63°F
Ent Air Temperature Dry-Bulb (Winter).....	65°F
Water Flow Per Ton .....	3.0 gpm
Unit Electrical .....	460/60/3

#### II. Initial Selection

Refer to performance data table, and pick a unit that has a capacity rating close to the design total cooling load and sensible cooling load. Multiple units may need selected in order to find the best match.

##### Unit Possibility #1

YL080, 7 ton unit  
 @ 90°F EWT, 22.0 gpm and 80/67 EA conditions  
 TC = 78,000 BTUH and SC = 57,800 BTUH  
 This unit does not meet required capacity.

##### Unit Possibility #2

YL095, 8 ton unit  
 @ 90°F EWT, 24.0 gpm and 80/67 EA conditions  
 TC = 90,800 BTUH and SC = 66,600 BTUH  
 This unit is within 10% of needed total cooling performance and of sensible cooling performance.

#### III. Correction Factors:

After the initial selection has been made we must determine our correction factors for entering water temperature, water flow, entering air, and airflow.

##### A. Entering Water Corrections:

Corrections for capacity based on different entering water temperatures can be made by interpolation of the performance table. The following interpolation will be used to find the capacity of a YL095 at 95°F EWT. Extrapolation of the performance table is not permitted.

$$TC @ 95°F = 90,800 + \frac{(95-90)}{(100-90)} \times (86,300 - 90,800)$$

$$TC @ 95°F = 88,550 \text{ BTUH}$$

Using the same methodology for sensible cooling.

$$SC @ 95°F = 66,600 \text{ BTUH}$$

##### B. Water flow Corrections:

Water flow corrections for capacity can be made by interpolation of the performance table. In this example, we are using a flow rate that is listed in the table, therefore interpolation is not necessary.

## Selection Example cont.

### C. Entering Air (EA) and Airflow (AF) Corrections:

The capacity is corrected using the equations below. It might be necessary to use interpolation in the tables to find the right correction factor. Once the correct factor is determined, use the equations below to find the final capacity of the unit at the design conditions.

$$\text{CORRECTED TC} = \text{TC} \times \text{EA} \times \text{AF}$$

$$\text{CORRECTED SC} = \text{SC} \times \text{EA} \times \text{AF}$$

The nominal cfm per ton of cooling can be determined by the following equation:

$$\begin{aligned} 1 \text{ ton} &= \text{BTUH} \div 12,000 \text{ BTUH/ton} \\ \text{Tons of cooling} &= 88,550 \div 12,000 = 7.38 \text{ tons} \\ \text{cfm} &= 2700 \\ \text{cfm/ton of clg} &= 2700 \div 7.38 \\ \text{nominal cfm/ton of clg} &= 365 \end{aligned}$$

For a YL095 at 75°F DB/ 63°F WB and 2700 cfm:

$$\begin{aligned} \text{CORRECTED TC} &= 88,550 \times 0.937 \times 0.998 \\ \text{CORRECTED TC} &= 82,105 \text{ BTUH} \end{aligned}$$

$$\begin{aligned} \text{CORRECTED SC} &= 66,600 \times 0.958 \times 0.992 \\ \text{CORRECTED SC} &= 63,290 \text{ BTUH} \end{aligned}$$

### IV. Blower Performance

Refer to blower performance data table to determine cfm capability at required external static pressure. Different blower packages are available to offer a large range of static capabilities. Sheave adjustments may be necessary to get the desired airflow at the external static pressure level.

For a YL095 with Package A:

At 2.0 turns open, the unit is capable of 2800 cfm at 0.60 in. w.g. This is within 5% of the design airflow. The drive sheave can be adjusted in 0.5 turn increments.

### V. Cooling Ratings

#### A. General ratings:

It is important to note that both the total cooling and sensible load must be met for the zone by the equipment. The actual unit capacity is within 5% of the design load which is acceptable.

### VI. Heating Ratings

#### A. General ratings:

Refer to heating capacity table and interpolate the capacity at 45°F EWT, 24.0 gpm and 2800 cfm at 70°F entering air conditions.

$$\text{Total Heating Capacity} = 83,100 \text{ BTUH}$$

### B. Dry Bulb and Airflow Corrections:

Find entering air dry bulb values in Entering Air Correction table. The correction factor for a dry bulb of 65°F is shown to be 1.011. In order to determine the correction factor for airflow, one must use the value based on nominal cfm/ton of cooling. It was determined in a previous step that the nominal cfm was approximately 365 cfm/ton of cooling. The correction factor for this was found to be 0.996. The total corrected heating capacity can be determined by the following equation:

$$\text{CORRECTED HC} = \text{HC} \times \text{EA} \times \text{AF}$$

For a YL095 at 65°F DB and 2700 cfm:

$$\text{CORRECTED HC} = 83,100 \times 1.011 \times 0.996$$

$$\text{CORRECTED HC} = 83,700 \text{ BTUH}$$

The design heating load was 91,000 BTUH and the actual capacity of the unit is only 83,700 BTUH. This unit will require a source of auxiliary heat to make up for the 7,300 BTUH that will be needed at the heating design point. Typically, a small 5 kW electric heat strip would be used to supplement the unit at this condition.

### VII. Final Results

YL095 (refer to model nomenclature):

$$\begin{aligned} \text{Total Cooling Capacity} &= 82,105 \text{ Btu/hr} \\ \text{Sensible Cooling Capacity} &= 63,290 \text{ Btu/hr} \end{aligned}$$

$$\text{Total Heating Capacity} = 83,700 \text{ Btu/hr}$$

## Antifreeze Correction

Catalog performance can be corrected for antifreeze use. Please use the following table and note the example given.

Antifreeze Type	Antifreeze % by wt	Cooling Capacity	Heating Capacity	Pressure Drop
EWT - degF [DegC]		<b>90 [32.2]</b>	<b>30 [-1.1]</b>	<b>30 [-1.1]</b>
Water	0	1.000	1.000	1.000
Ethylene Glycol	10	0.991	0.973	1.075
	20	0.979	0.943	1.163
	30	0.965	0.917	1.225
	40	0.955	0.890	1.324
	50	0.943	0.865	1.419
Propylene Glycol	10	0.981	0.958	1.130
	20	0.969	0.913	1.270
	30	0.950	0.854	1.433
	40	0.937	0.813	1.614
	50	0.922	0.770	1.816
Ethanol	10	0.991	0.927	1.242
	20	0.972	0.887	1.343
	30	0.947	0.856	1.383
	40	0.930	0.815	1.523
	50	0.911	0.779	1.639
Methanol	10	0.986	0.957	1.127
	20	0.970	0.924	1.197
	30	0.951	0.895	1.235
	40	0.936	0.863	1.323
	50	0.920	0.833	1.399

**Warning:**  
 Gray area represents antifreeze concentrations greater than 35% by weight and should be avoided due to the extreme performance penalty they represent.

### Antifreeze Correction Example

Antifreeze solution is Propylene Glycol 20% by weight. Determine the corrected heating and cooling performance at 30°F and 90°F respectively as well as pressure drop at 30°F for a Affinity Large Series YL080.

The corrected cooling capacity at 90°F would be:

$$78,000 \text{ MBtuh} \times 0.969 = 75,582 \text{ MBtuh}$$

The corrected heating capacity at 30°F would be:

$$60,300 \text{ MBtuh} \times 0.913 = 55,054 \text{ MBtuh}$$

The corrected pressure drop at 30°F and 22 GPM would be:

$$23.1 \text{ feet of head} \times 1.433 = 33.10 \text{ feet of head}$$

## Reference Calculations

Heating Calculations:	Cooling Calculations:
$LWT = EWT - \frac{HE}{GPM \times 500}$	$LWT = EWT + \frac{HR}{GPM \times 500}$
$LAT = EAT + \frac{HC}{CFM \times 1.08}$	$LAT (DB) = EAT (DB) - \frac{SC}{CFM \times 1.08}$
$TH = HC + HWC$	$LC = TC - SC$
	$S/T = \frac{SC}{TC}$

## Legend and Notes

### ABBREVIATIONS AND DEFINITIONS:

CFM = airflow, cubic feet/minute	HE = total heat of extraction, MBTUH
EWT = entering water temperature, Fahrenheit	HWC = hot water generator capacity, MBTUH
GPM = water flow in gallons/minute	EER = Energy Efficient Ratio = BTU output/Watt input
WPD = water pressure drop, PSI and feet of water	COP = Coefficient of Performance = BTU output/BTU input
EAT = entering air temperature, Fahrenheit (dry bulb/wet bulb)	LWT = leaving water temperature, °F
HC = air heating capacity, MBTUH	LAT = leaving air temperature, °F
TC = total cooling capacity, MBTUH	TH = total heating capacity, MBTUH
SC = sensible cooling capacity, MBTUH	LC = latent cooling capacity, MBTUH
KW = total power unit input, kilowatts	S/T = sensible to total cooling ratio
HR = total heat of rejection, MBTUH	

### Notes to Performance Data Tables

The following notes apply to all performance data tables:

- Performance ratings are based on 80°F DB / 67°F WB EAT for cooling and 70°F DB EAT for heating.
- Three flow rates are shown for each unit. The lowest flow rate shown is used for geothermal open loop/well water systems with a minimum of 50°F EWT. The middle flow rate shown is the minimum geothermal closed loop flow rate. The highest flow rate shown is optimum for geothermal closed loop systems and the suggested flow rate for boiler/tower applications.
- The hot water generator numbers are based on a flow rate of 0.4 GPM/ton of rated capacity with an EWT of 90°F.
- Entering water temperatures below 40°F assumes 15% antifreeze solution.
- For non-standard EAT conditions, apply the appropriate correction factors from the Correction Factor Tables.
- Interpolation between EWT, GPM and CFM data is permissible.

## Correction Factor Tables

### Air Flow Corrections (Dual Circuit)

Airflow		Cooling				Heating		
CFM Per Ton of Clg	% of Nominal	Total Cap	Sens Cap	Power	Heat of Rej	Htg Cap	Power	Heat of Ext
281	75%	0.981	0.910	0.956	0.976	0.956	1.049	0.947
299	80%	0.985	0.928	0.965	0.981	0.970	1.034	0.959
318	85%	0.988	0.947	0.975	0.986	0.977	1.027	0.968
337	90%	0.990	0.965	0.990	0.990	0.985	1.021	0.977
355	95%	0.996	0.985	0.995	0.997	0.992	1.014	0.986
<b>374</b>	<b>100%</b>	<b>1.000</b>	<b>1.000</b>	<b>1.000</b>	<b>1.000</b>	<b>1.000</b>	<b>1.000</b>	<b>1.000</b>
393	105%	1.005	1.030	1.012	1.014	1.010	0.993	1.005
412	110%	1.007	1.044	1.025	1.013	1.014	0.991	1.014
430	115%	1.010	1.065	1.035	1.018	1.021	0.987	1.024
449	120%	1.014	1.086	1.046	1.024	1.029	0.981	1.033
468	125%	1.017	1.106	1.059	1.027	1.040	0.980	1.039

07/25/07

### EA Corrections

#### Cooling Capacity Corrections

Entering Air WB °F	Total Clg Cap	Sensible Cooling Capacity Multipliers - Entering DB °F										Power Input	Heat of Rejection
		60	65	70	75	80	80.6	85	90	95	100		
55	0.898	0.723	0.866	1.048	1.185	*	*	*	*	*	*	0.985	0.913
60	0.912		0.632	0.880	1.078	1.244	1.260	*	*	*	*	0.994	0.927
65	0.967			0.694	0.881	1.079	1.085	1.270	*	*	*	0.997	0.972
66.2	0.983			0.655	0.842	1.040	1.060	1.232	*	*	*	0.999	0.986
<b>67</b>	<b>1.000</b>			0.616	0.806	<b>1.000</b>	1.023	1.193	1.330	*	*	<b>1.000</b>	<b>1.000</b>
70	1.053				0.693	0.879	0.900	1.075	1.250	1.404	*	1.003	1.044
75	1.168					0.687	0.715	0.875	1.040	1.261	1.476	1.007	1.141

NOTE: \* Sensible capacity equals total capacity at conditions shown.

11/10/09

#### Heating Capacity Corrections

Ent Air DB °F	Heating Corrections		
	Htg Cap	Power	Heat of Ext
45	1.062	0.739	1.158
50	1.050	0.790	1.130
55	1.037	0.842	1.096
60	1.025	0.893	1.064
65	1.012	0.945	1.030
68	1.005	0.976	1.012
<b>70</b>	<b>1.000</b>	<b>1.000</b>	<b>1.000</b>
75	0.987	1.048	0.970
80	0.975	1.099	0.930

11/10/09

## Operating Limits

Operating Limits	Cooling		Heating	
	(°F)	(°C)	(°F)	(°C)
<b>Air Limits</b>				
Min. Ambient Air	45	7.2	45	7.2
Rated Ambient Air	80	26.7	70	21.1
Max. Ambient Air	100	37.8	85	29.4
Min. Entering Air	50	10.0	40	4.4
Rated Entering Air db/wb	80.6/66.2	27/19	68	20.0
Max. Entering Air db/wb	110/83	43/28.3	80	26.7
<b>Water Limits</b>				
Min. Entering Water	30	-1.1	20	-6.7
Normal Entering Water	50-110	10-43.3	30-70	-1.1
Max. Entering Water	120	48.9	90	32.2

**NOTE:** Minimum/maximum limits are only for start-up conditions, and are meant for bringing the space up to occupancy temperature. Units are not designed to operate at the minimum/maximum conditions on a regular basis. The operating limits are dependant upon three primary factors: 1) water temperature, 2) return air temperature, and 3) ambient temperature. When any of the factors are at the minimum or maximum levels, the other two factors must be at the normal level for proper and reliable unit operation.

## Pressure Drop

Model	GPM	Pressure Drop (psi)				
		30°F	50°F	70°F	90°F	110°F
080	10.0	2.48	2.36	2.29	2.21	2.14
	16.0	5.96	5.62	5.22	4.89	4.69
	22.0	10.91	10.38	9.73	9.12	8.50
095	12.0	2.22	2.00	1.92	1.83	1.67
	18.0	4.62	4.02	3.80	3.75	3.65
	24.0	7.31	6.81	5.80	5.60	5.19
120	16.0	2.03	1.93	1.88	1.80	1.50
	22.0	3.69	3.58	3.40	3.19	2.99
	28.0	5.58	5.50	5.32	5.00	4.84
160	20.0	1.20	1.19	1.18	1.17	1.16
	28.0	2.64	2.50	2.37	2.24	2.12
	35.0	3.72	3.65	3.41	3.36	3.21
180	22.0	1.50	1.50	1.50	1.50	1.50
	34.0	3.95	3.90	3.85	3.80	3.75
	45.0	6.40	6.10	6.00	5.80	5.70
240	30.0	0.90	0.82	0.75	0.69	0.63
	45.0	2.22	2.06	1.91	1.77	1.64
	60.0	3.47	3.29	3.06	2.88	2.40
300	35.0	1.84	1.60	1.39	1.21	1.05
	56.0	4.09	3.88	3.69	3.51	3.33
	75.0	6.10	5.95	5.77	5.45	5.10

# Horizontal YL080 - Performance Data

## Belt Drive - Dual Circuit - 2600 CFM

EWT °F	WATER FLOW GPM	WPD		HEATING - EAT 70 °F					COOLING - EAT 80/67 °F					
		PSI	FT	HC	KW	HE	LAT	COP	TC	SC	S/T	KW	HR	EER
20	10.0	2.5	5.8	Operation not recommended					Operation not recommended					
	16.0	6.1	14.0	46.9	4.43	31.8	84.7	3.10						
	22.0	11.1	25.6	48.0	4.45	32.8	85.1	3.16						
30	10.0	2.5	5.8	Operation not recommended										
	16.0	6.0	13.8	54.9	4.53	39.4	87.5	3.55						
	22.0	10.9	25.2	55.9	4.56	40.3	87.9	3.59						
40	10.0	2.4	5.5	60.2	4.61	44.5	89.4	3.83	85.6	61.0	0.71	3.36	97.1	25.5
	16.0	5.8	13.4	62.8	4.66	47.0	90.4	3.96	79.6	58.0	0.73	3.15	90.4	25.2
	22.0	10.7	24.6	64.0	4.69	48.0	90.8	4.00	76.1	57.0	0.75	3.07	86.6	24.8
50	10.0	2.4	5.4	66.1	4.75	49.9	91.5	4.08	85.5	61.9	0.72	3.71	98.1	23.0
	16.0	5.6	13.0	70.6	4.80	54.2	93.1	4.31	82.5	60.8	0.74	3.53	94.6	23.4
	22.0	10.4	24.0	72.1	4.83	55.6	93.7	4.37	81.2	60.7	0.75	3.45	93.0	23.5
60	10.0	2.3	5.4	73.9	4.90	57.2	94.3	4.42	83.8	61.6	0.73	4.13	97.9	20.3
	16.0	5.4	12.5	78.0	4.94	61.1	95.8	4.62	83.3	61.9	0.74	3.91	96.6	21.3
	22.0	10.1	23.2	79.7	4.98	62.7	96.4	4.69	83.2	62.4	0.75	3.82	96.2	21.8
70	10.0	2.3	5.3	82.0	5.02	64.8	97.2	4.78	81.1	60.5	0.75	4.60	96.8	17.6
	16.0	5.2	12.1	84.7	5.08	67.4	98.2	4.89	82.2	61.5	0.75	4.31	96.9	19.1
	22.0	9.7	22.5	86.5	5.12	69.1	98.8	4.95	82.6	62.0	0.75	4.20	97.0	19.7
80	10.0	2.3	5.2	88.6	5.10	71.2	99.6	5.09	77.6	58.9	0.76	5.10	95.0	15.2
	16.0	5.0	11.6	90.5	5.19	72.8	100.2	5.12	79.6	60.1	0.76	4.75	95.8	16.7
	22.0	9.4	21.7	92.3	5.25	74.3	100.9	5.15	80.0	61.2	0.76	4.61	95.7	17.3
90	10.0	2.2	5.1	92.2	5.10	74.8	100.8	5.30	73.8	57.0	0.77	5.60	92.9	13.2
	16.0	4.9	11.3	95.3	5.26	77.4	102.0	5.31	75.6	58.0	0.77	5.26	93.5	14.4
	22.0	9.1	21.1	96.5	5.34	78.2	102.3	5.29	75.8	59.0	0.78	5.09	93.2	14.9
100	10.0	2.2	5.0	Operation not recommended					Operation not recommended					
	16.0	4.8	11.0						70.7	55.7	0.79	5.84	90.6	12.1
	22.0	8.8	20.2						70.6	56.2	0.80	5.65	89.9	12.5
110	10.0	2.1	4.9						Operation not recommended					
	16.0	4.7	10.8						65.0	53.4	0.82	6.51	87.2	10.0
	22.0	8.5	19.6						64.8	53.3	0.82	6.32	86.4	10.2
120	10.0	2.1	4.9	Operation not recommended										
	16.0	4.7	10.9	59.0	51.5	0.87	7.29	83.8	8.1					
	22.0	8.3	19.1	58.9	52.3	0.89	7.13	83.3	8.3					



# Horizontal YL095 - Performance Data

## Belt Drive - Dual Circuit - 3200 CFM

EWT °F	WATER FLOW GPM	WPD		HEATING - EAT 70 °F					COOLING - EAT 80/67 °F																	
		PSI	FT	HC	KW	HE	LAT	COP	TC	SC	S/T	KW	HR	EER												
20	12.0	2.1	4.9	Operation not recommended					Operation not recommended																	
	18.0	5.1	11.9	55.2	5.46	36.6	84.0	2.96																		
	24.0	7.2	16.6	56.8	5.52	38.0	84.4	3.02																		
30	12.0	2.1	4.9	Operation not recommended											Operation not recommended											
	18.0	4.6	10.7	71.6	5.57	52.6	88.7	3.77																		
	24.0	7.1	16.5	73.3	5.66	54.0	89.2	3.79																		
40	12.0	2.0	4.7	74.5	5.57	55.5	89.6	3.92													97.0	74.0	0.76	4.33	111.8	22.4
	18.0	4.3	9.8	82.6	5.70	63.2	91.9	4.25													93.5	72.5	0.78	4.05	107.3	23.1
	24.0	7.0	16.2	84.3	5.81	64.5	92.4	4.25													90.0	71.4	0.79	3.87	103.2	23.3
50	12.0	2.0	4.7	79.5	5.71	60.0	91.0	4.08	98.7	73.5	0.74	4.63	114.5	21.3												
	18.0	4.0	9.3	89.6	5.83	69.7	93.9	4.50	99.6	71.1	0.71	4.27	114.2	23.3												
	24.0	6.8	15.6	91.3	5.96	71.0	94.4	4.49	94.3	70.4	0.75	4.28	108.9	22.0												
60	12.0	2.0	4.5	85.6	5.84	65.7	92.8	4.30	97.8	72.5	0.74	5.05	90.8	19.4												
	18.0	3.9	9.0	94.1	5.97	73.8	95.2	4.62	101.3	70.0	0.69	4.64	117.1	21.8												
	24.0	6.5	14.9	95.9	6.09	75.1	95.7	4.61	95.8	69.7	0.73	4.71	111.9	20.3												
70	12.0	1.9	4.4	92.3	5.96	72.0	94.7	4.54	94.9	71.2	0.75	5.56	113.9	17.1												
	18.0	3.8	8.8	97.7	6.09	77.0	96.3	4.71	99.5	69.0	0.69	5.14	117.1	19.4												
	24.0	6.1	14.2	99.5	6.21	78.3	96.8	4.70	94.9	69.3	0.73	5.18	112.6	18.3												
80	12.0	1.8	4.2	98.7	6.06	78.0	96.6	4.78	90.7	69.6	0.77	6.12	111.5	14.8												
	18.0	3.8	8.7	102.0	6.19	80.8	97.5	4.83	95.1	68.0	0.72	5.75	114.7	16.6												
	24.0	5.8	13.4	103.7	6.31	82.2	98.0	4.82	92.1	68.5	0.74	5.69	111.5	16.2												
90	12.0	1.7	4.0	104.0	6.12	83.1	98.1	4.98	85.8	68.0	0.79	6.70	108.6	12.8												
	18.0	3.8	8.7	108.3	6.26	87.0	99.3	5.07	88.9	67.0	0.75	6.43	110.9	13.8												
	24.0	5.5	12.7	110.0	6.37	88.3	99.8	5.06	87.7	67.8	0.77	6.26	109.1	14.0												
100	12.0	1.7	3.9	Operation not recommended					Operation not recommended																	
	18.0	3.7	8.6						81.9	65.8	0.80	7.16	106.3	11.4												
	24.0	5.3	12.3						82.2	67.0	0.81	6.91	105.7	11.9												
110	12.0	1.7	3.9						Operation not recommended					Operation not recommended												
	18.0	3.6	8.4											74.9	64.4	0.86	7.93	101.9	9.4							
	24.0	5.2	12.0											75.9	65.9	0.87	7.65	102.0	9.9							
120	12.0	1.7	3.9											Operation not recommended					Operation not recommended							
	18.0	3.5	8.1																68.8	62.6	0.91	8.69	98.4	7.9		
	24.0	5.2	12.0																69.2	63.3	0.91	8.49	98.2	8.2		

# Horizontal YL120 - Performance Data

## Belt Drive - Dual Circuit - 3600 CFM

EWT °F	WATER FLOW GPM	WPD		HEATING - EAT 70 °F					COOLING - EAT 80/67 °F											
		PSI	FT	HC	KW	HE	LAT	COP	TC	SC	S/T	KW	HR	EER						
20	16.0	2.7	6.2	Operation not recommended					Operation not recommended											
	22.0	4.2	9.7	74.2	6.13	53.3	87.1	3.55												
	28.0	6.4	14.8	75.7	6.13	54.8	87.5	3.62												
30	16.0	2.6	6.0	Operation not recommended											Operation not recommended					
	22.0	4.1	9.4	88.0	6.25	66.7	90.6	4.13												
	28.0	6.2	14.3	90.1	6.21	68.9	91.2	4.25												
40	16.0	2.5	5.7	97.5	6.41	75.6	93.1	4.46	136.3	85.6	0.63	5.50	155.1	24.8						
	22.0	4.0	9.1	100.9	6.39	79.0	93.9	4.62	131.8	84.8	0.64	5.74	151.4	23.0						
	28.0	6.0	13.8	102.8	6.39	81.0	94.4	4.72	129.7	84.0	0.65	5.82	149.6	22.3						
50	16.0	2.4	5.6	106.7	6.55	84.4	95.5	4.78	133.6	84.0	0.63	6.36	155.3	21.0						
	22.0	3.9	8.9	113.2	6.56	90.9	97.1	5.06	133.0	83.7	0.63	6.34	154.6	21.0						
	28.0	5.8	13.4	114.8	6.62	92.3	97.5	5.08	133.4	83.9	0.63	6.29	154.8	21.2						
60	16.0	2.3	5.3	119.6	6.69	96.8	98.8	5.24	129.0	82.1	0.64	7.22	153.6	17.9						
	22.0	3.8	8.7	125.8	6.73	102.8	100.4	5.48	130.9	82.5	0.63	6.97	154.7	18.8						
	28.0	5.7	13.1	127.2	6.86	103.7	100.7	5.43	132.0	83.3	0.63	6.84	155.3	19.3						
70	16.0	2.2	5.0	134.2	6.82	111.0	102.5	5.77	123.3	80.0	0.65	8.07	150.8	15.3						
	22.0	3.7	8.5	139.0	6.88	115.6	103.8	5.92	126.4	81.0	0.64	7.66	152.5	16.5						
	28.0	5.5	12.7	140.8	7.07	116.7	104.2	5.84	126.9	82.0	0.65	7.48	152.4	17.0						
80	16.0	2.0	4.6	148.8	6.94	125.1	106.3	6.28	117.0	77.7	0.66	8.90	147.4	13.1						
	22.0	3.5	8.2	153.6	7.01	129.7	107.5	6.43	120.0	79.2	0.66	8.43	148.8	14.2						
	28.0	5.4	12.4	156.7	7.20	132.2	108.3	6.38	119.4	80.3	0.67	8.22	147.4	14.5						
90	16.0	1.8	4.2	161.5	7.07	137.4	109.5	6.70	110.8	75.5	0.68	9.71	143.9	11.4						
	22.0	3.4	7.8	170.0	7.09	145.8	111.7	7.03	112.6	77.0	0.68	9.29	144.3	12.1						
	28.0	5.2	12.0	176.0	7.20	151.4	113.3	7.16	110.8	78.0	0.70	9.06	141.7	12.2						
100	16.0	1.6	3.8	Operation not recommended					Operation not recommended											
	22.0	3.2	7.4						104.9	74.4	0.71	10.25	139.8	10.2						
	28.0	5.0	11.6						102.5	75.2	0.73	10.02	136.7	10.2						
110	16.0	1.5	3.5						Operation not recommended											
	22.0	3.0	6.9						97.5	71.2	0.73	11.34	136.2	8.6						
	28.0	4.8	11.2						95.8	71.8	0.75	11.10	133.7	8.6						
120	16.0	1.5	3.5	Operation not recommended																
	22.0	2.7	6.3	91.3	67.5	0.74	12.56	134.2	7.3											
	28.0	4.6	10.6	92.0	68.2	0.74	12.31	134.0	7.5											

# Vertical YL080 - Performance Data

## Belt Drive - Dual Circuit - 2600 CFM

EWT °F	WATER FLOW GPM	WPD		HEATING - EAT 70 °F					COOLING - EAT 80/67 °F					
		PSI	FT	HC	KW	HE	LAT	COP	TC	SC	S/T	KW	HR	EER
20	10.0	2.2	5.1	Operation not recommended					Operation not recommended					
	16.0	5.6	12.9	51.8	4.67	35.9	86.4	3.25						
	22.0	10.3	23.7	52.1	4.85	35.6	86.6	3.15						
30	10.0	2.2	5.1	Operation not recommended										
	16.0	5.5	12.7	59.8	4.85	43.3	89.3	3.62						
	22.0	10.0	23.1	60.3	4.92	43.5	89.5	3.59						
40	10.0	2.1	5.0	65.3	4.95	48.4	91.3	3.87	84.2	58.9	0.70	3.65	96.7	23.1
	16.0	5.3	12.3	68.0	5.01	50.9	92.2	3.98	78.1	55.1	0.71	3.35	89.5	23.3
	22.0	9.7	22.3	68.8	5.03	51.7	92.5	4.01	72.7	51.7	0.71	3.28	83.9	22.2
50	10.0	2.1	4.8	71.2	5.09	53.8	93.4	4.10	87.5	59.7	0.68	3.94	100.9	22.2
	16.0	5.2	12.0	76.0	5.16	58.4	95.1	4.32	84.0	59.3	0.71	3.67	96.5	22.9
	22.0	9.4	21.6	77.4	5.18	59.8	95.6	4.38	81.8	57.2	0.70	3.63	94.2	22.5
60	10.0	2.0	4.6	79.0	5.23	61.2	96.1	4.43	87.6	59.7	0.68	4.34	102.4	20.2
	16.0	5.0	11.6	83.7	5.31	65.6	97.8	4.63	86.2	61.0	0.71	4.04	100.0	21.3
	22.0	9.0	20.9	85.7	5.34	67.4	98.5	4.70	85.9	60.2	0.70	4.01	99.6	21.4
70	10.0	1.9	4.4	87.4	5.37	69.1	99.1	4.77	85.3	59.2	0.69	4.83	101.8	17.7
	16.0	4.9	11.2	91.0	5.45	72.4	100.4	4.89	85.3	60.8	0.71	4.48	100.6	19.1
	22.0	8.7	20.1	93.2	5.51	74.4	101.2	4.96	85.9	60.5	0.70	4.43	101.0	19.4
80	10.0	1.8	4.2	95.0	5.51	76.2	101.8	5.06	81.6	58.2	0.71	5.37	99.9	15.2
	16.0	4.7	10.8	97.5	5.60	78.4	102.7	5.10	82.2	59.3	0.72	4.97	99.2	16.5
	22.0	8.4	19.4	99.7	5.66	80.3	103.5	5.16	83.0	60.1	0.72	4.88	99.6	17.0
90	10.0	1.8	4.1	100.4	5.62	81.3	103.8	5.24	77.0	56.9	0.74	5.91	97.2	13.0
	16.0	4.5	10.5	103.2	5.77	83.5	104.7	5.25	77.6	56.9	0.73	5.53	96.5	14.0
	22.0	8.2	18.8	104.7	5.80	84.9	105.3	5.30	78.0	57.8	0.74	5.40	96.4	14.4
100	10.0	1.8	4.1	Operation not recommended					Operation not recommended					
	16.0	4.4	10.2						72.3	54.4	0.75	6.16	93.3	11.7
	22.0	7.9	18.2						72.0	54.4	0.76	5.98	92.4	12.0
110	10.0	1.8	4.1						Operation not recommended					
	16.0	4.3	9.9						67.0	52.2	0.78	6.86	90.4	9.8
	22.0	7.7	17.8						66.0	50.2	0.76	6.64	88.7	9.9
120	10.0	1.8	4.1	Operation not recommended										
	16.0	4.2	9.7	62.6	50.8	0.81	7.63	88.6	8.2					
	22.0	7.5	17.4	61.0	48.0	0.79	7.40	86.3	8.2					

# Vertical YL095 - Performance Data

## Belt Drive - Dual Circuit - 2800 CFM

EWT °F	WATER FLOW GPM	WPD		HEATING - EAT 70 °F					COOLING - EAT 80/67 °F											
		PSI	FT	HC	KW	HE	LAT	COP	TC	SC	S/T	KW	HR	EER						
20	12.0	2.2	5.1	Operation not recommended					Operation not recommended											
	18.0	4.7	10.9	56.8	5.42	38.3	86.8	3.07												
	24.0	8.0	18.6	57.8	5.47	39.1	87.1	3.10												
30	12.0	2.1	4.9	Operation not recommended											Operation not recommended					
	18.0	4.7	10.9	66.4	5.60	47.3	89.9	3.47												
	24.0	8.0	18.5	67.5	5.61	48.4	90.3	3.53												
40	12.0	2.0	4.6	73.5	5.72	54.0	92.3	3.77	101.6	70.9	0.70	4.14	115.8	24.5						
	18.0	4.6	10.7	76.4	5.78	56.7	93.3	3.88	97.5	66.1	0.68	3.80	110.4	25.7						
	24.0	7.8	18.1	77.9	5.77	58.2	93.8	3.96	93.6	62.7	0.67	3.71	106.3	25.2						
50	12.0	2.0	4.7	80.9	5.88	60.9	94.8	4.03	101.1	70.5	0.70	4.44	116.2	22.8						
	18.0	4.4	10.3	86.5	5.95	66.2	96.6	4.26	98.6	68.1	0.69	4.19	112.9	23.5						
	24.0	7.6	17.6	88.3	5.95	68.0	97.2	4.35	96.2	65.6	0.68	4.06	110.1	23.7						
60	12.0	2.0	4.6	91.0	6.06	70.3	98.1	4.40	98.8	69.8	0.71	4.89	115.5	20.2						
	18.0	4.2	9.8	96.4	6.13	75.5	99.9	4.61	97.8	68.8	0.70	4.62	113.6	21.2						
	24.0	7.3	16.9	98.5	6.14	77.5	100.6	4.70	97.1	67.5	0.69	4.48	112.4	21.7						
70	12.0	1.9	4.5	101.7	6.24	80.4	101.6	4.78	95.2	68.8	0.72	5.46	113.8	17.4						
	18.0	4.0	9.3	105.7	6.30	84.2	102.9	4.91	95.4	68.4	0.72	5.10	112.8	18.7						
	24.0	7.0	16.2	107.9	6.33	86.3	103.7	4.99	96.4	68.1	0.71	4.96	113.3	19.4						
80	12.0	1.9	4.3	111.4	6.41	89.5	104.8	5.10	90.8	67.6	0.74	6.08	111.6	14.9						
	18.0	3.8	8.9	114.0	6.48	91.9	105.7	5.16	91.9	67.3	0.73	5.65	111.1	16.3						
	24.0	6.7	15.5	116.1	6.52	93.9	106.4	5.22	94.2	68.3	0.72	5.50	113.0	17.1						
90	12.0	1.8	4.1	118.0	6.56	95.6	107.0	5.28	86.2	66.2	0.77	6.69	109.0	12.9						
	18.0	3.7	8.5	121.0	6.65	98.3	108.0	5.33	87.5	65.5	0.75	6.26	108.9	14.0						
	24.0	6.5	15.0	122.7	6.69	99.9	108.6	5.38	90.8	67.4	0.74	6.10	111.6	14.9						
100	12.0	1.7	4.0	Operation not recommended					Operation not recommended											
	18.0	3.6	8.3						82.8	63.4	0.77	6.95	106.5	11.9						
	24.0	6.3	14.5						86.3	65.8	0.76	6.76	109.4	12.8						
110	12.0	1.7	3.8						Operation not recommended					Operation not recommended						
	18.0	3.6	8.3											78.0	61.3	0.79	7.73	104.4	10.1	
	24.0	6.2	14.2											80.8	63.5	0.79	7.48	106.4	10.8	
120	12.0	1.6	3.7	Operation not recommended										Operation not recommended						
	18.0	3.7	8.5											73.6	59.4	0.81	8.60	103.0	8.6	
	24.0	6.2	14.3											74.6	61.4	0.82	8.26	102.8	9.0	

# Vertical YL120 - Performance Data

## Belt Drive - Dual Circuit - 3600 CFM

EWT °F	WATER FLOW GPM	WPD		HEATING - EAT 70 °F					COOLING - EAT 80/67 °F					
		PSI	FT	HC	KW	HE	LAT	COP	TC	SC	S/T	KW	HR	EER
20	16.0	2.1	4.9	Operation not recommended					Operation not recommended					
	22.0	4.0	9.2	69.6	7.41	44.3	85.9	2.75						
	28.0	5.8	13.4	72.1	7.42	46.8	86.5	2.85						
30	16.0	2.1	4.9	Operation not recommended										
	22.0	3.8	8.8	82.3	7.60	56.4	89.2	3.17						
	28.0	5.7	13.1	84.2	7.61	58.3	89.7	3.24						
40	16.0	2.0	4.7	92.6	7.69	66.4	91.8	3.53	140.9	100.0	0.71	6.04	161.5	23.3
	22.0	3.7	8.5	96.3	7.83	69.5	92.8	3.60	138.5	99.0	0.71	5.75	158.1	24.1
	28.0	5.6	12.9	98.0	7.86	71.2	93.2	3.66	137.2	98.0	0.71	5.59	156.3	24.5
50	16.0	1.9	4.5	103.4	7.94	76.3	94.6	3.82	136.9	97.3	0.71	6.47	158.9	21.2
	22.0	3.6	8.3	110.8	8.10	83.2	96.5	4.01	137.0	97.8	0.71	6.24	158.3	22.0
	28.0	5.5	12.7	112.8	8.14	85.0	97.0	4.06	135.5	97.1	0.72	6.07	156.2	22.3
60	16.0	1.9	4.4	118.3	8.24	90.1	98.4	4.21	130.9	94.2	0.72	7.08	155.1	18.5
	22.0	3.5	8.1	125.4	8.39	96.8	100.3	4.38	132.8	95.6	0.72	6.81	156.0	19.5
	28.0	5.4	12.5	128.0	8.45	99.2	100.9	4.44	131.6	95.5	0.73	6.63	154.2	19.9
70	16.0	1.9	4.3	134.2	8.58	104.9	102.5	4.58	123.7	90.8	0.73	7.83	150.4	15.8
	22.0	3.4	7.9	139.6	8.71	109.8	103.9	4.70	126.6	92.5	0.73	7.47	152.1	16.9
	28.0	5.3	12.3	142.9	8.78	113.0	104.8	4.77	126.1	93.0	0.74	7.27	150.8	17.3
80	16.0	1.9	4.3	148.2	8.95	117.6	106.1	4.85	116.1	87.3	0.75	8.65	145.6	13.4
	22.0	3.3	7.6	152.6	9.05	121.7	107.2	4.94	119.1	88.9	0.75	8.22	147.1	14.5
	28.0	5.2	12.0	157.0	9.12	125.9	108.4	5.04	119.3	90.4	0.76	8.00	146.6	14.9
90	16.0	1.8	4.2	157.2	9.36	125.3	108.4	4.92	108.7	83.9	0.77	9.48	141.1	11.5
	22.0	3.2	7.4	164.0	9.41	131.9	110.2	5.11	111.0	85.0	0.77	9.07	142.0	12.2
	28.0	5.0	11.6	169.5	9.47	137.2	111.6	5.25	112.0	87.0	0.78	8.83	142.1	12.7
100	16.0	1.7	3.9	Operation not recommended					Operation not recommended					
	22.0	3.1	7.1						103.1	81.1	0.79	10.02	137.2	10.3
	28.0	4.8	11.1						104.5	83.1	0.79	9.77	137.9	10.7
110	16.0	1.4	3.3						Operation not recommended					
	22.0	2.9	6.7						95.9	77.3	0.81	11.07	133.7	8.7
	28.0	4.5	10.4						97.5	78.7	0.81	10.81	134.4	9.0
120	16.0	1.4	3.3	Operation not recommended										
	22.0	2.7	6.2	90.4	74.1	0.82	12.23	132.1	7.4					
	28.0	4.1	9.5	91.3	75.0	0.82	11.98	132.2	7.6					

# Vertical YL160 - Performance Data

## Belt Drive - Dual Circuit - 5000 CFM

EWT °F	WATER FLOW GPM	WPD		HEATING - EAT 70 °F					COOLING - EAT 80/67 °F					
		PSI	FT	HC	KW	HE	LAT	COP	TC	SC	S/T	KW	HR	EER
20	20.0	1.2	2.8	Operation not recommended					Operation not recommended					
	28.0	2.7	6.3	Operation not recommended					Operation not recommended					
	35.0	3.9	8.9	Operation not recommended					Operation not recommended					
30	20.0	1.2	2.8	Operation not recommended					Operation not recommended					
	28.0	2.6	6.1	87.3	8.70	57.6	84.2	2.94	Operation not recommended					
	35.0	3.7	8.6	89.1	8.87	58.8	84.5	2.94	Operation not recommended					
40	20.0	1.2	2.8	98.2	8.91	67.8	86.2	3.23	168.0	119.0	0.71	7.66	194.1	21.9
	28.0	2.6	5.9	101.2	8.97	70.6	86.7	3.31	171.0	120.2	0.70	7.40	196.3	23.1
	35.0	3.7	8.5	103.6	9.10	72.5	87.2	3.34	174.0	122.0	0.70	7.27	198.8	23.9
50	20.0	1.2	2.7	111.9	9.19	80.6	88.7	3.57	163.5	117.8	0.72	8.22	191.5	19.9
	28.0	2.5	5.8	115.2	9.26	83.6	89.3	3.65	167.1	119.3	0.71	7.93	194.2	21.1
	35.0	3.7	8.4	118.1	9.32	86.2	89.9	3.71	170.3	120.6	0.71	7.68	196.5	22.2
60	20.0	1.2	2.7	124.1	9.48	91.8	91.0	3.84	159.3	114.3	0.72	8.84	189.4	18.0
	28.0	2.4	5.6	127.8	9.56	95.1	91.7	3.92	162.0	115.8	0.72	8.54	191.1	19.0
	35.0	3.5	8.2	130.9	9.64	98.0	92.2	3.98	164.4	117.2	0.71	8.27	192.6	19.9
70	20.0	1.2	2.7	136.4	9.77	103.0	93.3	4.09	155.0	110.8	0.71	9.46	187.3	16.4
	28.0	2.4	5.5	140.3	9.86	106.7	94.0	4.17	156.8	112.4	0.72	9.14	188.0	17.2
	35.0	3.4	7.9	143.8	9.95	109.8	94.6	4.23	158.4	113.8	0.72	8.86	188.6	17.9
80	20.0	1.2	2.7	148.6	10.07	114.2	95.5	4.33	149.2	106.9	0.72	10.30	184.4	14.5
	28.0	2.3	5.3	151.4	10.11	116.9	96.0	4.39	151.0	108.5	0.72	9.98	185.1	15.1
	35.0	3.4	7.8	154.8	10.21	119.9	96.7	4.44	152.6	109.9	0.72	9.70	185.7	15.7
90	20.0	1.2	2.7	160.8	10.31	125.6	97.8	4.57	141.7	101.8	0.72	10.90	178.9	13.0
	28.0	2.2	5.2	162.5	10.37	127.1	98.1	4.59	144.8	103.4	0.71	10.71	181.3	13.5
	35.0	3.4	7.8	165.8	10.47	130.0	98.7	4.64	146.8	106.0	0.72	10.54	182.8	13.9
100	20.0	1.2	2.7	Operation not recommended					Operation not recommended					
	28.0	2.2	5.0	Operation not recommended					136.7	101.3	0.74	11.80	176.9	11.6
	35.0	3.2	7.5	Operation not recommended					138.7	103.5	0.75	11.62	178.4	11.9
110	20.0	1.2	2.7	Operation not recommended					Operation not recommended					
	28.0	2.1	4.9	Operation not recommended					128.4	99.0	0.77	12.90	172.4	10.0
	35.0	3.2	7.4	Operation not recommended					130.7	101.1	0.77	12.71	174.0	10.3
120	20.0	1.2	2.7	Operation not recommended					Operation not recommended					
	28.0	2.1	4.8	Operation not recommended					118.0	95.2	0.81	14.27	166.7	8.3
	35.0	3.0	6.9	Operation not recommended					120.4	97.0	0.81	13.99	168.2	8.6

# Vertical YL180 - Performance Data

## Belt Drive - Dual Circuit - 5600 CFM

EWT °F	WATER FLOW GPM	WPD		HEATING - EAT 70 °F					COOLING - EAT 80/67 °F					
		PSI	FT	HC	KW	HE	LAT	COP	TC	SC	S/T	KW	HR	EER
20	22.0	1.5	3.5	Operation not recommended					Operation not recommended					
	34.0	4.0	9.2											
	45.0	6.4	14.9											
30	22.0	1.5	3.5	Operation not recommended					Operation not recommended					
	34.0	4.0	9.1	119.7	10.20	84.9	87.8	3.44						
	45.0	6.4	14.8	123.0	10.33	87.8	88.3	3.49						
40	22.0	1.5	3.5	129.6	10.43	94.1	89.4	3.64	176.8	122.3	0.69	8.78	206.8	20.1
	34.0	3.9	9.1	134.9	10.64	98.6	90.3	3.72	179.7	127.8	0.71	8.42	208.4	21.3
	45.0	6.3	14.4	140.0	10.82	103.1	91.1	3.79	182.8	129.7	0.71	8.03	210.2	22.8
50	22.0	1.5	3.5	146.0	10.89	108.8	92.1	3.93	172.5	121.3	0.70	9.49	204.9	18.2
	34.0	3.9	9.0	151.7	11.10	113.9	93.1	4.01	175.7	124.7	0.71	9.11	206.8	19.3
	45.0	6.1	14.1	157.0	11.30	118.4	94.0	4.07	178.7	127.8	0.72	8.77	208.6	20.4
60	22.0	1.5	3.5	166.1	11.39	127.2	95.5	4.27	168.4	120.3	0.71	10.30	203.5	16.3
	34.0	3.9	8.9	172.3	11.60	132.7	96.5	4.35	172.1	123.2	0.72	9.91	205.9	17.4
	45.0	6.1	14.0	178.0	11.79	137.8	97.4	4.42	175.4	125.8	0.72	9.55	208.0	18.4
70	22.0	1.5	3.5	186.1	11.89	145.5	98.8	4.59	164.3	119.3	0.73	11.11	202.2	14.8
	34.0	3.8	8.9	192.8	12.09	151.6	99.9	4.67	168.4	121.6	0.72	10.70	204.9	15.7
	45.0	6.0	13.9	199.0	12.28	157.1	100.9	4.75	172.1	123.8	0.72	10.33	207.3	16.7
80	22.0	1.5	3.5	210.6	12.43	168.2	102.8	4.97	161.0	117.6	0.73	11.98	201.9	13.4
	34.0	3.8	8.8	217.9	12.62	174.8	104.0	5.06	165.1	119.9	0.73	11.57	204.5	14.3
	45.0	5.9	13.6	224.0	12.79	180.4	105.0	5.13	168.8	122.1	0.72	11.20	207.0	15.1
90	22.0	1.5	3.5	237.8	12.99	193.5	107.3	5.37	159.7	115.5	0.72	13.02	204.1	12.3
	34.0	3.8	8.8	245.6	13.18	200.7	108.6	5.46	163.2	117.3	0.72	12.54	206.0	13.0
	45.0	5.8	13.4	249.0	13.30	203.6	109.2	5.49	165.5	120.3	0.73	12.06	206.6	13.7
100	22.0	1.5	3.5	Operation not recommended					Operation not recommended					
	34.0	3.8	8.7						159.2	115.7	0.73	13.63	205.7	11.7
	45.0	5.7	13.2						161.7	118.4	0.73	13.23	206.8	12.2
110	22.0	1.5	3.5	Operation not recommended					Operation not recommended					
	34.0	3.7	8.7						155.1	114.0	0.73	14.78	205.5	10.5
	45.0	5.7	13.2						157.8	116.4	0.74	14.40	206.9	11.0
120	22.0	1.5	3.5	Operation not recommended					Operation not recommended					
	34.0	3.7	8.6						151.9	112.8	0.74	16.01	206.5	9.5
	45.0	5.6	12.9						155.0	115.0	0.74	15.75	208.7	9.8

# Vertical YL240 - Performance Data

## Belt Drive - Dual Circuit - 7600 CFM

EWT °F	WATER FLOW GPM	WPD		HEATING - EAT 70 °F					COOLING - EAT 80/67 °F										
		PSI	FT	HC	KW	HE	LAT	COP	TC	SC	S/T	KW	HR	EER					
20	30.0	0.9	2.2	Operation not recommended					Operation not recommended										
	45.0	2.3	5.3																
	60.0	3.7	8.6																
30	30.0	0.9	2.1	Operation not recommended					Operation not recommended										
	45.0	2.2	5.1												178.9	10.81	142.0	89.8	4.85
	60.0	3.5	8.0												192.0	10.93	154.7	91.4	5.15
40	30.0	0.9	2.0	192.4	11.12	154.5	91.4	5.07	267.0	178.0	0.67	9.13	298.1	29.3					
	45.0	2.1	4.9	200.6	11.22	162.3	92.4	5.24	268.7	182.7	0.68	8.82	298.8	30.5					
	60.0	3.4	7.8	212.9	11.35	174.1	93.9	5.50	273.3	185.5	0.68	8.73	303.1	31.3					
50	30.0	0.8	1.9	215.1	11.51	175.9	94.2	5.48	266.3	180.4	0.68	9.69	299.4	27.5					
	45.0	2.1	4.7	224.4	11.64	184.7	95.3	5.65	268.2	182.2	0.68	9.39	300.2	28.6					
	60.0	3.3	7.6	233.7	11.78	193.5	96.5	5.82	270.0	184.0	0.68	9.08	301.0	29.7					
60	30.0	0.8	1.8	242.6	11.92	201.9	97.6	5.96	258.2	175.7	0.68	10.32	293.4	25.0					
	45.0	2.0	4.6	253.3	12.10	212.0	98.9	6.14	260.3	177.8	0.68	10.02	294.5	26.0					
	60.0	3.2	7.3	264.0	12.27	222.1	100.2	6.31	262.4	180.0	0.69	9.72	295.5	27.0					
70	30.0	0.8	1.7	270.1	12.34	228.0	100.9	6.42	250.2	171.0	0.68	10.94	287.5	22.9					
	45.0	1.9	4.4	282.2	12.55	239.4	102.4	6.59	252.4	173.5	0.69	10.65	288.8	23.7					
	60.0	3.1	7.1	294.3	12.77	250.8	103.9	6.76	254.7	175.9	0.69	10.35	290.0	24.6					
80	30.0	0.7	1.7	303.3	12.77	259.7	104.9	6.96	235.4	168.2	0.71	11.67	275.3	20.2					
	45.0	1.8	4.2	317.2	13.03	272.7	106.6	7.13	237.7	170.7	0.72	11.38	276.5	20.9					
	60.0	3.0	6.9	327.2	13.22	282.0	107.9	7.25	240.0	173.2	0.72	11.08	277.8	21.7					
90	30.0	0.7	1.6	339.8	13.22	294.7	109.4	7.53	217.3	163.6	0.75	12.36	259.5	17.6					
	45.0	1.8	4.1	355.6	13.53	309.5	111.3	7.70	222.0	166.1	0.75	12.12	263.4	18.3					
	60.0	2.9	6.7	360.0	13.68	313.3	111.9	7.71	225.2	170.4	0.76	11.81	265.5	19.1					
100	30.0	0.7	1.5	Operation not recommended					Operation not recommended										
	45.0	1.7	3.9						209.2	160.0	0.76	12.87	253.1	16.3					
	60.0	2.7	6.3						212.4	163.6	0.77	12.84	256.2	16.5					
110	30.0	0.6	1.4	Operation not recommended					Operation not recommended										
	45.0	1.6	3.8						196.1	153.4	0.78	13.70	242.9	14.3					
	60.0	2.4	5.5						199.5	156.7	0.79	13.86	246.8	14.4					
120	30.0	0.6	1.4	Operation not recommended					Operation not recommended										
	45.0	1.6	3.6						182.1	147.2	0.81	14.59	231.9	12.5					
	60.0	2.4	5.5						185.9	150.0	0.81	14.91	236.7	12.5					



# Vertical YL300 - Performance Data

## Belt Drive - Dual Circuit - 9500 CFM

EWT °F	WATER FLOW GPM	WPD		HEATING - EAT 70 °F					COOLING - EAT 80/67 °F										
		PSI	FT	HC	KW	HE	LAT	COP	TC	SC	S/T	KW	HR	EER					
20	35.0	2.0	4.6	Operation not recommended					Operation not recommended										
	56.0	4.2	9.7																
	75.0	6.3	14.7																
30	35.0	1.8	4.3	Operation not recommended					Operation not recommended										
	56.0	4.1	9.4												218.4	17.07	160.2	89.3	3.75
	75.0	6.1	14.1												225.0	17.15	166.5	89.9	3.85
40	35.0	1.7	4.0	233.3	17.71	172.9	90.7	3.86	305.4	209.0	0.68	12.95	349.6	23.6					
	56.0	4.0	9.2	244.1	17.74	183.6	91.8	4.03	314.6	211.1	0.67	12.36	356.7	25.4					
	75.0	6.0	13.9	254.7	17.87	193.7	92.8	4.18	320.0	214.3	0.67	11.84	360.4	27.0					
50	35.0	1.6	3.7	259.0	18.25	196.7	93.2	4.16	297.0	207.8	0.70	14.25	345.6	20.8					
	56.0	3.9	9.0	272.3	18.42	209.5	94.5	4.33	303.8	210.5	0.69	13.60	350.2	22.3					
	75.0	6.0	13.7	284.4	18.58	221.0	95.7	4.49	310.0	213.0	0.69	13.02	354.4	23.8					
60	35.0	1.5	3.5	289.6	18.82	225.4	96.2	4.51	289.4	206.6	0.71	15.77	343.2	18.3					
	56.0	3.8	8.7	306.3	19.16	240.9	97.9	4.68	296.6	209.2	0.71	15.06	348.0	19.7					
	75.0	5.9	13.5	321.4	19.47	255.0	99.3	4.84	303.1	211.5	0.70	14.41	352.3	21.0					
70	35.0	1.4	3.2	320.2	19.39	254.0	99.2	4.84	281.7	205.4	0.73	17.30	340.7	16.3					
	56.0	3.7	8.5	340.2	19.90	272.3	101.2	5.01	289.3	207.8	0.72	16.51	345.7	17.5					
	75.0	5.8	13.3	358.4	20.36	288.9	102.9	5.16	296.3	210.0	0.71	15.80	350.2	18.7					
80	35.0	1.3	3.0	356.7	19.98	288.5	102.8	5.23	274.6	204.5	0.74	18.82	338.8	14.6					
	56.0	3.6	8.3	381.1	20.68	310.5	105.1	5.40	282.2	206.9	0.73	18.03	343.7	15.7					
	75.0	5.6	13.0	399.2	21.18	326.9	106.9	5.52	289.1	209.1	0.72	17.32	348.2	16.7					
90	35.0	1.2	2.8	396.7	20.59	326.4	106.7	5.65	267.4	199.9	0.75	21.03	339.2	12.7					
	56.0	3.5	8.1	426.0	21.49	352.6	109.5	5.81	275.4	202.9	0.74	19.87	343.2	13.9					
	75.0	5.5	12.6	440.0	22.00	364.9	110.9	5.86	282.0	208.1	0.74	18.84	346.3	15.0					
100	35.0	1.1	2.6	Operation not recommended					Operation not recommended										
	56.0	3.4	7.9						268.7	199.5	0.74	22.12	344.2	12.1					
	75.0	5.3	12.2						275.0	204.0	0.74	20.85	346.2	13.2					
110	35.0	1.0	2.4	Operation not recommended					Operation not recommended										
	56.0	3.3	7.7						263.4	195.6	0.74	24.38	346.6	10.8					
	75.0	5.1	11.8						268.0	199.8	0.75	22.87	346.0	11.7					
120	35.0	1.0	2.3	Operation not recommended					Operation not recommended										
	56.0	3.2	7.5						252.8	193.6	0.77	26.86	344.5	9.4					
	75.0	5.0	11.6						258.0	197.3	0.76	25.33	344.4	10.2					

# Wiring Schematic - Dual Compressor with Aurora

460/-575/60/3

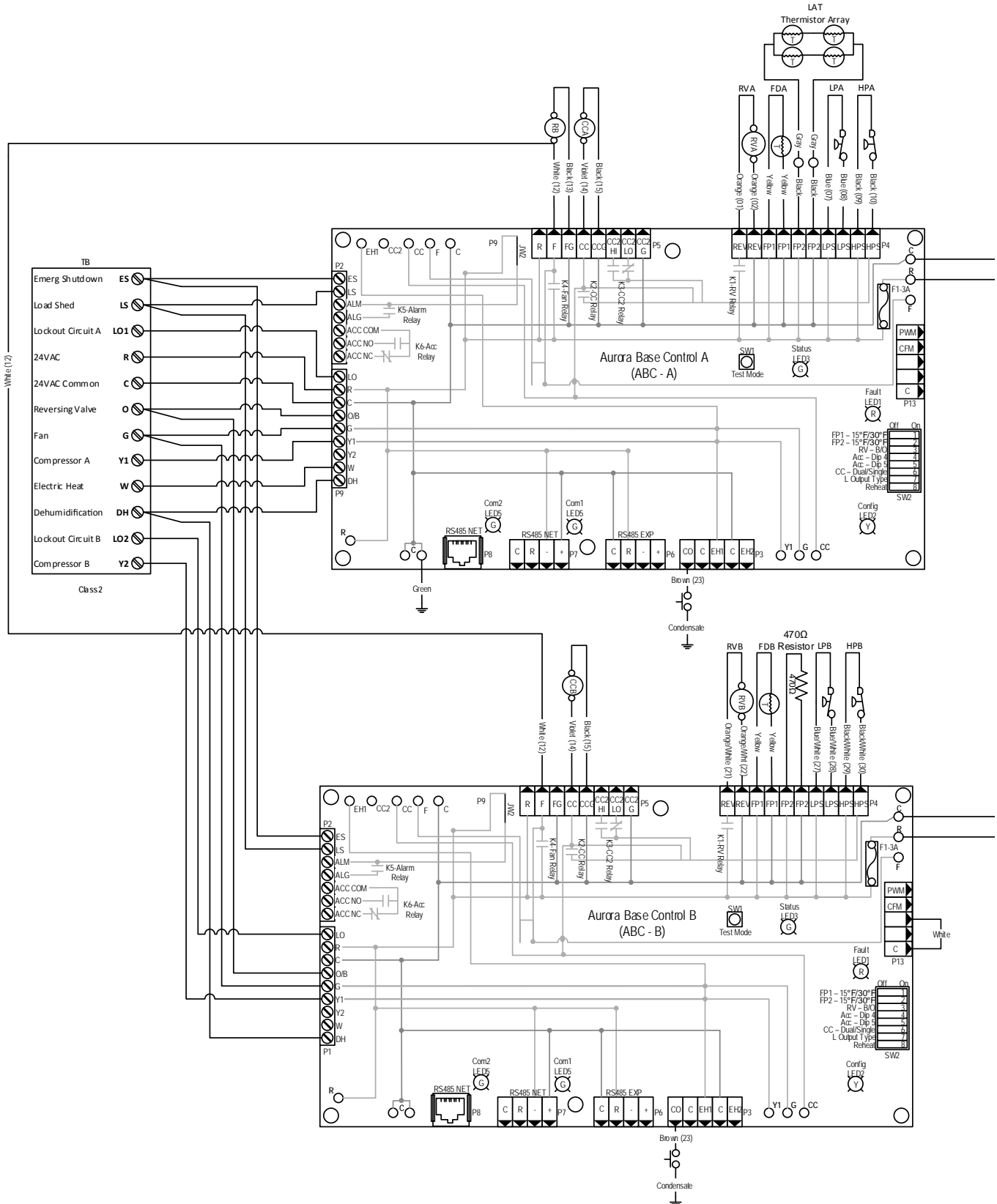

# Wiring Schematic - Dual Compressor with Aurora

460-575/60/3

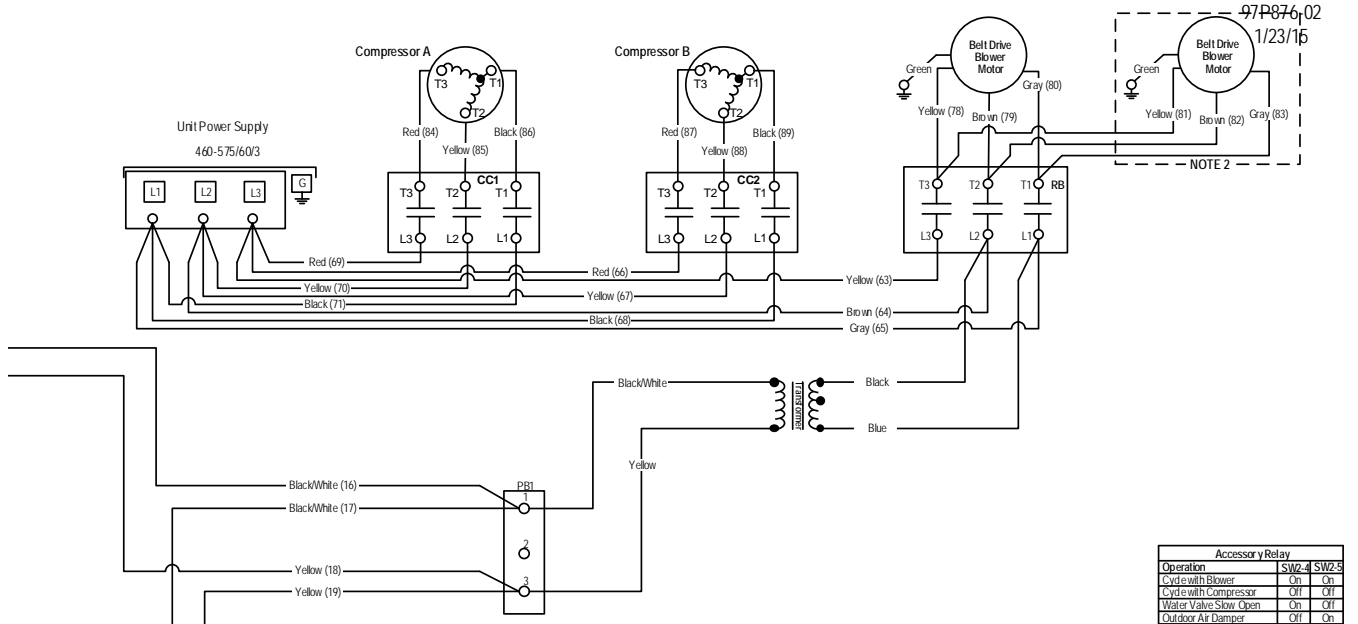

Accessory Relay		
Operation	SW2	SW2-5
Cycle with Blower	On	On
Cycle with Compressor	Off	Off
Water Valve Slow Open	On	Off
Outdoor Air Damper	Off	On

Aurora Timing Events		
Event	Normal Mode	Test Mode
Random Start Delay	5 to 80 seconds	1 second
Compressor On Delay	5 seconds	< 1 second
Compressor Minimum On Time	2 minutes	5 seconds
Compressor Short Cycle Delay	4 minutes	15 seconds
Blower Off Delay	30 seconds	2 seconds
Fault Recognition Delay - High Pressure	Less than 1 second	Less than 1 second
Start-Up Bypass - Low Pressure	2 minutes	30 seconds
Fault Recognition Delay - Low Pressure	30 seconds	30 seconds
Start-Up Bypass - Low Water/Air Coil Limit	2 minutes	30 seconds
Fault Recognition Delay - Low Water/Air Coil Limit	30 seconds	30 seconds
Fault Recognition Delay - Condensate Overflow	30 seconds	30 seconds
Thermostat Call Recognition Time	2 seconds	2 seconds
Auxiliary Heat Staging Delay	5 minutes	20 seconds
Emergency Heat Staging Delay	2 minutes	7.5 seconds
Water Valve Slow Open Delay	90 seconds	90 seconds
Reheat Delay	30 seconds	30 seconds

Aurora LED Flash Codes					
Slow Flash	1 second on and 1 second off				
Fast Flash	100 milliseconds on and 100 milliseconds off				
Flash Code	100 milliseconds on and 400 milliseconds off with a 2 second pause before repeating				
Random Start Delay					
Status LED (LED1, Green)	Fast Flash				
Configuration LED (LED2, Yellow)	Fast Flash				
Fault LED (LED3, Red)	Fast Flash				
Status LED (LED1, Green)		Configuration LED (LED2, Yellow)		Fault LED (LED3, Red)	
Normal Mode	ON	No Software Override	Flash ECM Setting	Normal Mode	OFF
Control Is Non-Functional	OFF	DIP Switch Override	Slow Flash	Input Fault Lockout	Flash Code 1
Test Mode	Slow Flash	ECM Configure Mode	Fast Flash	High Pressure Lockout	Flash Code 2
Lockout Active	Fast Flash	Reset Configure Mode	Off	Low Pressure Lockout	Flash Code 3
Dehumidification Mode	Flash Code 2			Low Air Coil Limit Lockout - FP2	Flash Code 4
Resized	Flash Code 3			Low Water Coil Limit Lockout - FP1	Flash Code 5
Reserved	Flash Code 4			Reserved	Flash Code 6
Load Shed	Flash Code 5			Condensate Overflow Lockout	Flash Code 7
E-SD	Flash Code 6			Over/Under Voltage Shutdown	Flash Code 8
Reserved	Flash Code 7			Reserved	Flash Code 9
				Reserved	Flash Code 10
				Air/Water Coil Limit Sensor Error	Flash Code 11

### Legend

	Factory Low Voltage Wiring		Thermistor
	Factory Line Voltage Wiring		Relay Coil
	Field Low Voltage Wiring		Switch - Condensate Overflow
	Field Line Voltage Wiring		Switch - High pressure
	Optional Block		Switch - Low pressure
	DC Voltage/PCB Traces		Polarized connector
	Field Zone Sensor Wiring		Light Emitting Diode - Green
	Internal Junction		Light Emitting Diode - Yellow
	Quick Connect Terminal		Light Emitting Diode - Red
	Field Wiring Lug		
	Ground		
	Relay Contacts - N.O., N.C.		
	Capacitor		
	Fuse		

CCA - Compressor Contactor A  
CCB - Compressor Contactor B  
CO - Condensate Overflow Sensor  
ES - Emergency Shutdown  
HPA - High Pressure Switch A  
HPB - High Pressure Switch B  
LPA - Low Pressure Switch A  
LPB - Low Pressure Switch B  
FDA - Freeze De-Iction Sensor A  
FDB - Freeze De-Iction Sensor B  
F1 - Fuse

SW1 - Push button  
SW2 - DIP package 8 position  
RVA - Reversing Valve Coil A  
RVB - Reversing Valve Coil B  
PGM - Phase Guard Monitor  
RH - Reheat Valve Coil

**Notes:**

1 - Only on units equipped with two fan motors.

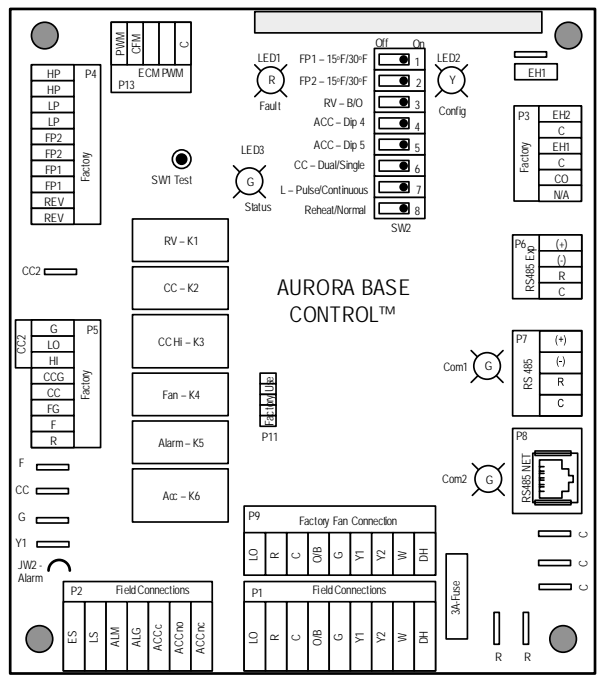

## Engineering Guide Specifications

### General

Furnish and install York Water Source Heat Pumps, as indicated on the plans. Equipment shall be completely assembled, piped and internally wired. Capacities and characteristics as listed in the schedule and the specifications that follow. The reverse cycle heating/cooling units shall be either suspended type with horizontal air inlet and discharge or floor mounted type with horizontal air inlet and vertical upflow/side air discharge. Units shall be AHRI/ISO 13256-1 certified (080-120) and listed by a nationally recognized safety-testing laboratory or agency, such as ETL Testing Laboratory. Each unit shall be computer run-tested at the factory with conditioned water and operation verified to catalog data. The units shall be designed to operate with entering liquid temperature between 20°F and 120°F [-6.7°C and 48.9°C]. Refer to the performance data tables actual operating range.

### Casing and Cabinet

The cabinet shall be fabricated from heavy-gauge galvanized steel and finished with corrosion-resistant powder coating (vertical units). This corrosion protection system shall meet the stringent 1000 hour salt spray test per ASTM B117. The interior shall be insulated with 1/2-inch thick, multi-density, Cleanable aluminum foil coated glass fiber with edges sealed or tucked under flanges to prevent the introduction of glass fibers into the discharge air. Standard cabinet panel insulation must meet NFPA 90A requirements, air erosion and mold growth limits of UL-181, stringent fungal resistance test per ASTM-C1071 and ASTM G21, and shall meet zero level bacteria growth per ASTM G22. Unit insulation must meet these stringent requirements or unit(s) will not be accepted.

Blower and compressor compartment access panels shall be 'lift-out' removable with supply and return ductwork in place.

A duct collar shall be provided on the supply air opening. Standard size 2 in. [5.1 cm] disposable filters shall be provided with each unit. The upflow vertical units shall have a removable insulated divider panel between the air handling section and the compressor section to minimize the transmission of compressor noise and to permit operational service testing without air bypass. Vertical units shall be supplied with left or right horizontal air inlet and top or side air discharge. Horizontal units shall be supplied with left or right air inlet and end or side air discharge.

Option: A 2 in. [5.1 cm] wide MERV 13 filter shall be installed in filter rack for high efficiency filter applications.

The compressor shall be double isolation mounted (160-300) using selected durometer grommets to provide vibration free compressor mounting. The compressor mounting bracket shall be acoustically deadened galvanized steel to prevent vibration transmission to the cabinet.

Option: A Super Quiet Sound package shall include multi-density full coverage compressor blanket.

The drain pan shall be of plastic (080-120) or stainless steel (080-300) construction to inhibit corrosion inhibit bacterial growth. Drain outlet shall be located on pan as to allow complete and unobstructed drainage of condensate. The unit as standard will be supplied with solid-state electronic condensate overflow protection. Mechanical float switches WILL NOT be accepted. Vertical units shall be furnished with a copper FPT condensate drain connection and an internal factory installed condensate trap. Horizontal units shall have a pipe drain connection suitable for standard 3/4 in. PVC glue fittings.

### Refrigerant Circuit

All units shall utilize the non-ozone depleting and low global warming potential refrigerant R-410A. All units shall contain a sealed refrigerant circuit including a hermetic motor-compressor, bidirectional thermostatic expansion valve, finned tube air-to-refrigerant heat exchanger, reversing valve, coaxial tube water-to-refrigerant heat exchanger, optional hot water generator coil, and service ports.

Compressors shall be high-efficiency single scroll type designed for heat pump duty and mounted on vibration isolators.

The air coil shall be sized for low-face velocity and constructed of lanced aluminum fins bonded to rifled aluminum tubes in a staggered pattern not less than three rows deep for enhanced performance. AlumiSeal™ electro-coated air coil for maximum protection against formicary corrosion.

The coaxial water-to-refrigerant heat exchanger shall be designed for low water pressure drop and constructed of a convoluted copper inner tube and a steel outer tube. Refrigerant to air heat exchangers shall utilize enhanced corrugated lanced aluminum fins and rifled copper tube construction rated to withstand 600 PSIG (4135 kPa) refrigerant working pressure. Refrigerant to water heat exchangers shall be of copper inner water tube and steel refrigerant outer tube design, rated to withstand 600 PSIG (4135 kPa) working refrigerant pressure and 450 PSIG (3101 kPa) working water pressure. The thermostatic expansion valve shall provide proper superheat over the entire liquid temperature range with minimal "hunting." The valve shall operate bidirectionally without the use of check valves.

Option: Cupronickel refrigerant to water heat exchangers shall be of copper-nickel inner water tube and steel refrigerant outer tube design, rated to withstand 600 PSIG (4135 kPa) working refrigerant pressure and 450 PSIG (3101 kPa) working water pressure. Water lines shall also be of cupronickel construction.

Option: Insulated water-to-refrigerant heat exchanger and refrigerant suction lines shall be insulated to prevent condensation at low liquid temperatures.

## Engineering Guide Specifications cont.

---

Option: Insulated water-to-refrigerant heat exchanger, water lines and refrigerant suction lines shall be insulated to prevent condensation at low liquid temperatures below 50 °F.

### Blower and Motor Assembly

All units shall have belt-driven centrifugal blowers. Blower motors shall be permanently lubricated with thermal overload protection. Units supplied without permanently lubricated motors must provide external oilers for easy service. The blower shall be double-width double inlet forward curved with dynamically balanced wheels. Blower motors shall be 1725 rpm, 56 frame sealed ball bearing type. The drive shall include fixed pitch blower sheave and variable pitch motor sheave sized for 115% of the blower brake horsepower. The blower and motor assembly must be capable of overcoming the external static pressures as shown on the schedule. Airflow / Static pressure rating of the unit shall be based on a wet coil and a clean filter in place. Ratings based on a dry coil and/or no filter, or on an ESP less than 0.25 in. (6.35 mm w.g.) shall NOT be acceptable.

Option: Various blower drive packages for selectable static pressure/airflow.

Option: High static blower motors available on select models.

### Electrical

A control box shall be located within the unit compressor compartment and shall contain a 75VA transformer, 24 Volt activated, 2 pole compressor contactor, terminal block for thermostat wiring and solid-state controller for complete unit operation. Electro-mechanical operation WILL NOT be accepted. Units shall be name-plated for use with time delay fuses or HACR circuit breakers. Unit controls shall be 24 Volt and provide heating or cooling as required by the remote thermostat/sensor.

An Aurora microprocessor-based controller that interfaces with a multi-stage electronic thermostat to monitor and control unit operation shall be provided. The control shall provide operational sequencing, blower speed control, high and low pressure switch monitoring, freeze detection, condensate overflow sensing, lockout mode control, LED status and fault indicators, fault memory, field selectable options and accessory output. The control shall provide fault retry three times before locking out to limit nuisance trips.

A detachable terminal block with screw terminals will be provided for field control wiring. All units shall have knockouts for entrance of low and line voltage wiring. The blower motor and control box shall be harness plug wired for easy removal.

### Piping

Supply and return water connections shall be copper fittings which eliminate the need for backup wrenches when making field connections. Optionally, all water piping shall be insulated to prevent condensation at low liquid temperatures.



## Revision Guide

---

Pages:	Description:	Date:	By:
All	Removed FX10 Control Option, Added Aurora Controls	01 June 2015	MA
4,29	Updated Nomenclature, Updated Physical Data Table	23 Jan 2015	MA
All	First Published	21 Oct 2013	DS







Product: **Affinity Large Series**  
Type: Geothermal Heat Pumps  
Size: 7-25 Ton Dual Capacity

Document Type: Specification Catalog  
Part Number: SC1021AK6A  
Release Date: 06/15

©2015 The manufacturer has a policy of continual product research and development and reserves the right to change design and specifications without notice.

York and Affinity are registered trademarks of Johnson Controls, Inc., and are used with permission.