



Heating and Air Conditioning

**SPECIFICATION CATALOG**  
**AFFINITY CONSOLE**  
**COMMERCIAL GEOTHERMAL/  
WATER SOURCE HEAT PUMPS**  
**SINGLE CAPACITY**

**MODELS:**

**YC09 - 18**

**(.75 THRU 1.5 NOMINAL TONS)**



Due to continuous product improvement, specifications are subject to change without notice.

Visit us on the web at [www.yorkgeothermal.com](http://www.yorkgeothermal.com)

Additional rating information can found at  
[www.ahridirectory.org](http://www.ahridirectory.org)

FOR DISTRIBUTION USE ONLY - NOT TO BE USED AT POINT OF RETAIL SALE



## Table of Contents

---

Model Nomenclature .....	4
AHRI Data .....	5
The Affinity Console .....	7
Inside the Affinity Console .....	8
Controls .....	9
Application Notes .....	12
Water Quality .....	20
Installation Notes .....	21
Selection Example .....	22
Dimensional Data .....	24
Physical Data .....	31
Electrical Data .....	32
Auxiliary Heat Ratings .....	33
Blower Performance Data .....	33
Pressure Drop .....	34
Correction Factor Tables .....	34
Reference Calculations .....	35
Legend and Notes .....	35
Operating Limits .....	35
Performance Data .....	36
Wiring Schematics .....	40
Engineering Guide Specifications .....	46
Revision Guide .....	49

# Model Nomenclature

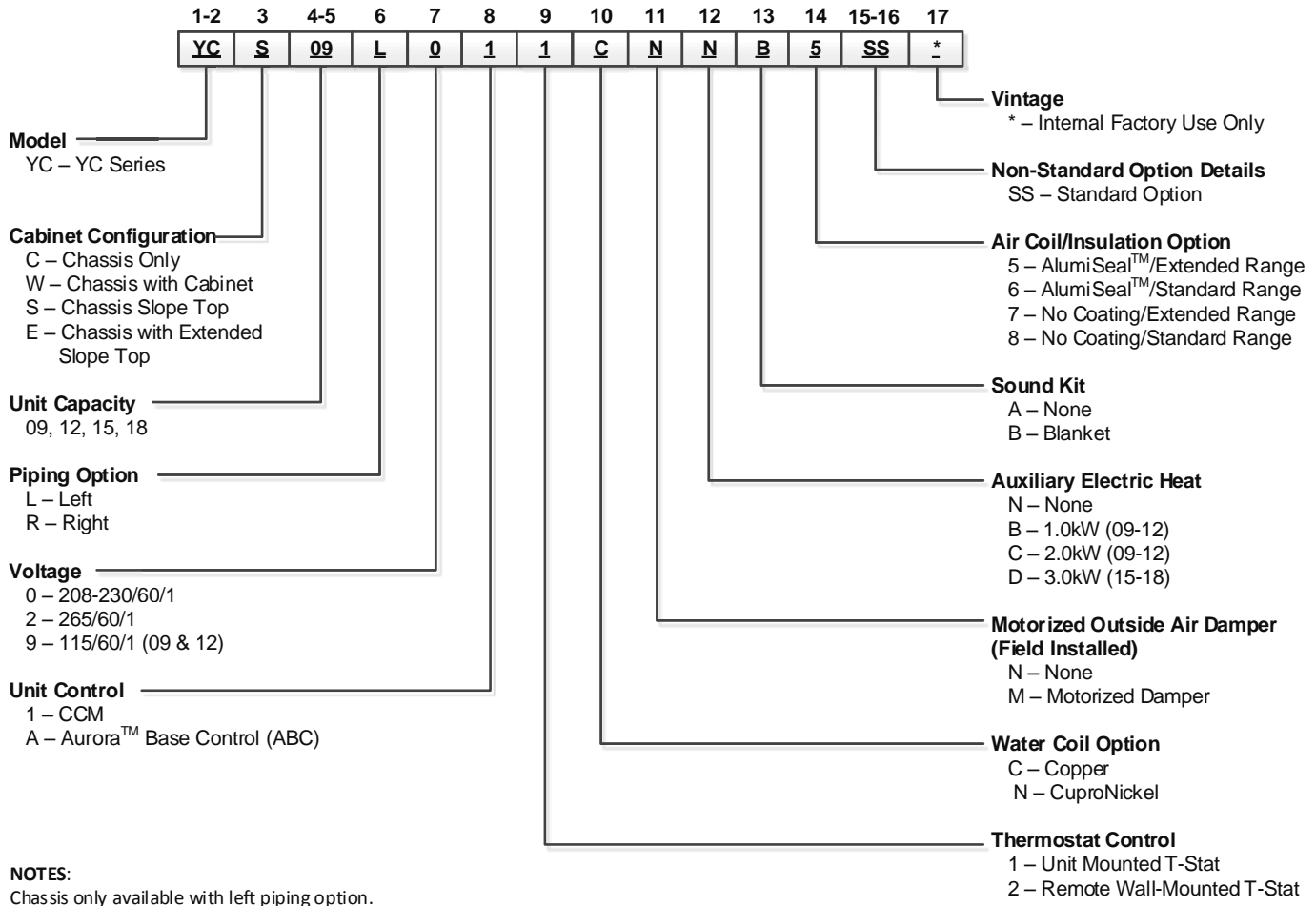

## Voltage Availability

Voltage	Model			
	09	12	15	18
115/60/1	•	•		
208-230/60/1	•	•	•	•
265/60/1	•	•	•	•

1/20/14



All Affinity Console Series product is Safety listed under UL1995 thru ETL and performance listed with AHRI in accordance with standard 13256-1.

# AHRI Data

## ECM Motors

AHRI/ASHRAE/ISO 13256-1

English (IP) Units

Model	Flow Rate		Water Loop Heat Pump				Ground Water Heat Pump				Ground Loop Heat Pump			
			Cooling EWT 86°F		Heating EWT 68°F		Cooling EWT 59°F		Heating EWT 50°F		Cooling EWT 77°F		Heating EWT 32°F	
	gpm	cfm	Capacity Btuh	EER Btuh/W	Capacity Btuh	COP	Capacity Btuh	EER Btuh/W	Capacity Btuh	COP	Capacity Btuh	EER Btuh/W	Capacity Btuh	COP
<b>09</b>	2.5	300	8,500	13.4	10,500	4.4	10,200	22.5	8,700	3.8	9,000	16.0	6,700	3.1
<b>12</b>	3.5	350	10,500	12.3	14,400	4.3	12,400	19.5	11,800	3.7	11,000	14.2	9,500	3.5
<b>15</b>	4.5	450	13,500	13.6	17,000	4.9	16,200	22.0	14,000	4.1	14,200	15.9	10,500	3.4
<b>18</b>	5.5	500	16,200	12.5	21,000	4.4	19,000	19.6	17,000	3.7	16,600	15.1	13,300	3.1

Cooling capacities based upon 80.6°F DB, 66.2°F WB entering air temperature  
 Heating capacities based upon 68°F DB, 59°F WB entering air temperature  
 All ratings based upon operation at the lower voltage of dual voltage rated models.

12/14/09

## AHRI Data cont.

The performance standard AHRI/ASHRAE/ISO 13256-1 became effective January 1, 2000 and replaces ARI Standards 320, 325, and 330. This new standard has three major categories: Water Loop (comparable to ARI 320), Ground Water (ARI 325), and Ground Loop (ARI 330). Although these standards are similar there are some differences:

### Unit of Measure: The Cooling COP

The cooling efficiency is measured in EER (US version measured in Btuh per Watt. The Metric version is measured in a cooling COP (Watt per Watt) similar to the traditional COP measurement.

### Water Conditions Differences

Entering water temperatures have changed to reflect the centigrade temperature scale. For instance the water loop heating test is performed with 68°F (20°C) water rounded down from the old 70°F (21.1°C).

### Air Conditions Differences

Entering air temperatures have also changed (rounded down) to reflect the centigrade temperature scale. For instance the cooling tests are performed with 80.6°F (27°C) dry bulb and 66.2°F (19°C) wet bulb entering air instead of the traditional 80°F (26.7°C) DB and 67°F (19.4°C) WB entering air temperatures. 80.6/66.2 data may be converted to 80/67 using the entering air correction table. This represents a significantly lower relative humidity than the old 80/67 of 50% and will result in lower latent capacities.

### Pump Power Correction Calculation

Within each model, only one water flow rate is specified for all three groups and pumping Watts are calculated using the following formula. This additional power is added onto the existing power consumption.

- Pump power correction = (gpm x 0.0631) x (Press Drop x 2990) / 300

Where 'gpm' is waterflow in gpm and 'Press Drop' is the pressure drop through the unit heat exchanger at rated water flow in feet of head.

### Blower Power Correction Calculation

Blower power is corrected to zero external static pressure using the following equation. The nominal airflow is rated at a specific external static pressure. This effectively reduces the power consumption of the unit and increases cooling capacity but decreases heating capacity. These Watts are significant enough in most cases to increase EER and COPs fairly dramatically over ARI 320, 325, and 330 ratings.

- Blower Power Correction = (cfm x 0.472) x (esp x 249) / 300

Where 'cfm' is airflow in cfm and 'esp' is the external static pressure at rated airflow in inches of water gauge.

### ISO Capacity and Efficiency Calculations

The following equations illustrate cooling calculations:

- ISO Cooling Capacity = Cooling Capacity (Btuh) + (Blower Power Correction (Watts) x 3.412)
- ISO EER Efficiency (W/W) = ISO Cooling Capacity (Btuh) x 3.412 / [Power Input (Watts) - Blower Power Correction (Watts) + Pump Power Correction (Watt)]

The following equations illustrate heating calculations:

- ISO Heating Capacity = Heating Capacity (Btuh) - (Blower Power Correction (Watts) x 3.412)
- ISO COP Efficiency (W/W) = ISO Heating Capacity (Btuh) x 3.412 / [Power Input (Watts) - Blower Power Correction (Watts) + Pump Power Correction (Watt)]

### Comparison of Test Conditions

	ARI 320	ISO/AHRI 13256-1 WLHP	ARI 325	ISO/AHRI 13256-1 GWHP	ARI 330	ISO/AHRI 13256-1 GLHP
<b>Cooling</b>						
Entering Air - DB/WB °F	80/67	80.6/66.2	80/67	80.6/66.2	80/67	80.6/66.2
Entering Water - °F	85	86	50/70	59	77	77
Fluid Flow Rate	*	**	**	**	**	**
<b>Heating</b>						
Entering Air - DB/WB °F	70	68	70	68	70	68
Entering Water - °F	70	68	50/70	50	32	32
Fluid Flow Rate	*	**	**	**	**	**

Note \*: Flow rate is set by 10°F rise in standard cooling test  
Part load entering water conditions not shown.

Note \*\*: Flow rate is specified by the manufacturer

WLHP = Water Loop Heat Pump; GWHP = Ground Water Heat Pump; GLHP = Ground Loop Heat Pump

### Conversions:

Airflow (lps) = CFM x 0.472;

ESP (Pascals) = ESP (in wg) x 249;

WaterFlow (lps) = GPM x 0.0631;

Press Drop (Pascals) = Press Drop (ft hd) x 2990

## The Affinity Console

The Affinity Console Series provides:

- Highest efficiencies and lowest operating costs
- Broadest R410A product line
- Standard or extended range (geothermal) operation
- Quiet operation
- Flexible control options

### Affinity Console Series Console Models

YCC 09-18 (3/4-1.5 tons) Chassis Only

YCW 09-18 (3/4-1.5 tons) Flat top cabinet

YCS 09-18 (3/4-1.5 tons) Slope top cabinet

YCE 09-18 (3/4-1.5 tons) Extended Slope Top cabinet



### High Efficiency

Affinity Console Series is the highest efficiency units available. Large oversized air coils, water to refrigerant heat exchangers and rotary compressors provide extremely efficient operation. This efficiency means the Affinity Console Series requires less loop than any product on the market. This can mean significant savings on commercial projects.

### Quiet Operation

All Affinity Console Series Console product is ARI 350 sound rated using third party sound testing. Room Noise Criteria Curves (NC Curve) may be calculated using data from the ARI 350 ratings giving the engineer total flexibility in assuring a quiet environment.

### Standard Features

- Slope and Flat top configurations
- Extended cabinet options
- Footprint matches "legacy" products for easy retrofits.
- Attractive rounded corners heavy gauge cabinet.
- Quiet rotary compressors in all models.
- 2-dimension refrigerant piping vibration loops to isolate the compressor.
- All interior cabinet surfaces including the compressor compartment are insulated with 1/2" [12.7mm] thick
- 1-1/2lb [681g] density, surface coated, acoustic type glass fiber insulation.

### Easy Maintenance and Service Advantages

- 2 removable compressor access panels
- Separate air handler and compressor section access panels permit service testing without bypass.
- Easy access to low voltage connector for easy thermostat wiring (remote & thermostat option).
- Quick attach wiring harnesses are used throughout for fast servicing.
- High and low pressure refrigerant service ports.
- Internal slide out blowers.

### Factory Quality

- All refrigerant brazing is performed in a nitrogen environment.
- Computer controlled deep vacuum and refrigerant charging system.
- All joints are leak detected for maximum leak rate of less than 1/4 oz. per year.
- Computer bar code equipped assembly line insures all components are correct.
- All units are computer run-tested with water to verify both function and performance.

## Inside the Affinity Console

### Refrigerant

Affinity Console Series products all feature zero ozone depletion and low global warming potential refrigerant R-410A.

### Cabinet

All units are all constructed of corrosion resistant galvanized sheet metal with white polyester powder coat paint rated for more than 1000 hours of salt spray. Refrigerant circuit is designed to allow primary serviceability from the front. One access panel allows servicing of the blower motor, blower, and drain pan. Cabinet is designed to match "industry" foot print for ease of replacement.

### Drain Pan

All condensate connections are welded stainless steel tubes for economical corrosion free connections. Bacteria resistant stainless steel drain pan is designed to promote complete drainage and will never rust or corrode. Complete drainage helps to inhibit bacterial or microbial growth. Units feature an internally trapped condensate line.

### Compressors

High efficiency R-410A rotary compressors are used on every model. Rotary compressors (available in 208-230V & 265V 60Hz Single Phase) provide both the highest efficiency available and great reliability.

### Electrical Box

Unit controls feature quick connect wiring harnesses for easy servicing. Large 75VA transformer assures adequate controls power for accessories.

### Thermostatic Expansion Valve

All Affinity Console Series models utilize a balanced port bi-directional thermostatic expansion valve (TXV) for refrigerant metering. This allows precise refrigerant flow in a wide range of entering water variation (20 to 120°F [-7 to 49 °C]) found in geothermal systems.



### Water to Refrigerant Coaxial Heat Exchanger Coil

Large oversized coaxial refrigerant to water heat exchangers provide unparalleled efficiency. The coaxes are designed for low pressure drop and low flow rates. All coaxes are pressure rated to 450 psi water side and 600 psi on the refrigerant side. Optional ThermaShield coated water-to-refrigerant coaxial heat exchanger is available to prevent condensation in low temperature loop operation.



### Service Connections and Serviceability

Two Schrader service ports are provided in every unit. The suction side and discharge side ports are for field charging and servicing access. All valves are 7/16" SAE connections. All water and electrical connections are made from the front of the unit. Unit is designed for front access serviceability.



### 4-Way Reversing Valve

Affinity Console Series units feature a reliable all-brass pilot operated refrigerant reversing valve. The reversing valve operation is limited to change of mode by the control to enhance reliability.



### 3-Speed ECM Constant Torque Motors

The 3-speed ECM is a 'Constant Torque' ECM motor and delivers air flow similar to a PSC but operates as efficiently as a variable speed ECM motor. Because it is an ECM motor, the 3-speed ECM can ramp slowly up or down like the variable speed ECM motor. There are 3 possible speed taps available on the 3-speed ECM motor with #1 being the lowest airflow and #3 being the highest airflow. These speed selections are preset at the time of manufacture and are easily changed in the field if necessary.

### All-Aluminum Air Coil

These air coils are constructed of lanced fin and rifled tube aluminum that is not susceptible to formicary corrosion. For additional condensate runoff and meeting project specifications, an optional AlumiSeal e-coating is available.



# Controls

Control	General Description	Application	Display/Interface	Protocol	Thermostat Options
<b>CCM Control</b> 	The CCM (Compressor control module) is a more reliable replacement for electro-mechanical control applications. It features a small microprocessor board that handles the lockout function of the unit. A second microprocessor handles the unit mounted thermostat for maintaining accurate room temperature.	Residential and commercial applications requiring minimal but reliable controls. Includes Random Start, High and low pressure switches and auto changeover capability.	Dial thermostat with Hi and Low blower speeds, and auto changeover or cont blower selection switches.	None	<b>Unit Mounted Digital Dial Thermostat</b>
					<b>Remote Mounted Standard Thermostat</b>

## Standard CCM Control Features

Compressor control module (CCM) controls are standard on the Affinity Console Series console heat pump. This control features unit mounted thermostat and switches,

Features of the standard control are:

- Easy to understand color coded thermostat adjustment markings.
- Large, rocker type mode and blower switches.
- Internally mounted blower switch to choose cycled or constant blower operation.
- High pressure and low pressure safety controls to protect the unit components.
- Lockout circuit to shut down unit operation upon receipt of a fault indicator from the safety controls.
- A 24 volt control circuit allows for safe and easy diagnosis.

The user selects either "Heat/Cool" or "Fan Only" on the mode switch, then either "High" or "Low" at the blower speed switch. The temperature can be controlled by rotating the thermostat control knob.

The "Fan Only" setting provides constant blower operation.

**Figure 6: Unit Mounted Control**

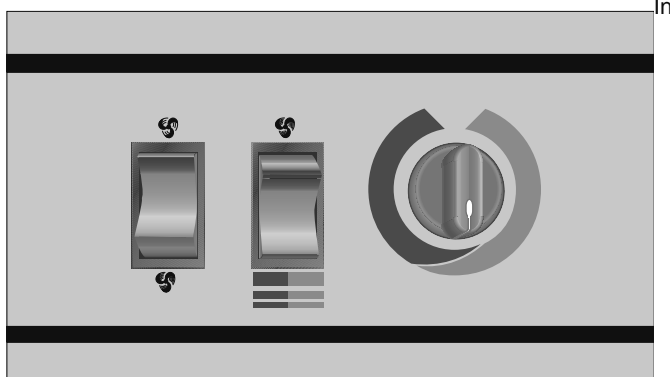

In the "Heat" mode, a call for heat by the thermostat closes the compressor contactor contacts, energizing the compressor, which will run until the thermostat is satisfied.

In the "Cool" mode, a call for cooling by the thermostat energizes the reversing valve and closes the compressor contactor contacts, energizing the compressor, which will run until the thermostat is satisfied.

The emergency electric heat operation in the "Heat/Cool" mode is subject to the setting of the internally mounted mode switch. The optional, factory installed electric heat will operate when the internally mounted mode switch is in the "Emergency Heat" mode. In the "Heat" mode, a call for heating energizes the blower and electric heater contactor, energizing the electric heat elements and blower, which will run until the thermostat is satisfied. When the internally mounted mode switch is in the "Normal/Boilerless" mode the unit operates in its normal "Heat/Cool" operation, unless there is an aquastat controller. When the normally open circuit of the aquastat closes and the unit is in the heating mode, it will switch to the "Emergency Heat" condition until the thermostat is satisfied or the aquastat opens restarting the compressor.

If either the low or high pressure safety switches are opened, the compressor and reversing valve are disabled by the lockout relay. Unit operation will resume only after the voltage to the unit is interrupted or the mode switch is placed in the "Off" position.

If the electric heat limit switches are opened, the electric heat is disabled.

## Controls cont.

### Aurora ‘Base’ Control



**NOTE:** Refer to the Aurora Base Control Application and Troubleshooting Guide and the Instruction Guide: Aurora Interface and Diagnostics (AID) Tool for additional information.

### Control Features

#### Software ABC Standard Version 3.0

#### Single or Dual Capacity Compressors

Either single or dual capacity compressors can be operated.

#### Variable Speed ECM

##### Blower Motor Option (If Applicable)

A Variable Speed ECM blower motor can be driven directly using the onboard PWM output. Four blower speeds are available based upon the G, Y1, Y2, and W input signals to the board. The blower speeds can be changed either by the ECM manual configurations mode method or by using the Aurora AID Tool directly. All four blower speeds can be set to the same speed if desired.

##### 5-Speed ECM Blower Motor Option (If Applicable)

A 5-Speed ECM blower motor will be driven directly using the thermostat connections. Any of the G, Y1, or Y2/W signals can drive any of the 5 available pre-programmed blower speeds on the motor. All 5 Series "G" vintage units will be wired this way at the factory.

### Other Control Features

- Random start at power up
- Anti-short cycle protection
- High and low pressure cutouts
- Loss of charge
- Water coil freeze detection
- Air coil freeze detection
- Over/under voltage protection
- Condensate overflow sensor
- Load shed
- Dehumidification (where applicable)
- Emergency shutdown
- Hot gas reheat operation (where applicable)
- Diagnostic LED
- Test mode push button switch
- Two auxiliary electric heat outputs
- Alarm output
- Accessory output with N.O. and N.C.
- Modbus communication (master)
- Modbus communication (slave)

### Field Selectable Options via Hardware

**DIP Switch (SW1)** – Test/Configuration Button (See SW1 Operation Table)

#### Test Mode

The control is placed in the test mode by holding the push button switch SW1 for 2 - 5 seconds. In test mode most of the control timings will be shortened by a factor of sixteen (16). LED3 (green) will flash at 1 second on and 1 second off. Additionally, when entering test mode LED1 (red) will flash the last lockout one time. Test mode will automatically time out after 30 minutes. Test mode can be exited by pressing and holding the SW1 button for 2 to 5 seconds or by cycling the power. **NOTE:** Test mode will automatically be exited after 30 minutes.

#### Variable Speed ECM Configuration Mode (If Applicable)

The control is placed in the ECM configuration mode by holding the pushbutton switch SW1 for 5 to 10 seconds, the high, low, and "G" ECM speeds can be selected by following the LED display lights. LED2 (yellow) will fast flash when entering the ECM configuration. When setting "G" speed LED3 (green) will be continuously lit, for low speed LED1 (red) will be continuously lit, and for high speed both LED3 (green) and LED1 (red) will be continuously lit. During the ECM configuration mode LED2 (yellow) will flash each of the 12 possible blower speeds 3 times. When the desired speed is flashed press SW1, LED2 will fast flash until SW1 is released. "G" speed has now been selected. Next select low speed, and high speed blower selections following the same process above. After third selection has been made, the control will exit the ECM configuration mode. Aux fan speed will remain at default or current setting and requires the AID Tool for adjustment.

#### Reset Configuration Mode

The control is placed in reset configuration mode by holding the push button switch SW1 for 50 to 60 seconds. This will reset all configuration settings and the EEPROM back to the factory default settings. LED3 (green) will turn off when entering reset configuration mode. Once LED3 (green) turns off, release SW1 and the control will reset.

#### DIP Switch (SW2)

**SW2-1** FP1 Selection – Low water coil temperature limit setting for freeze detection. On = 30°F; Off = 15°F.

**SW2-2** FP2 Selection – On = 30°F; Off = N/A

**SW2-3** RV – O/B - thermostat type. Heat pump thermostats with "O" output in cooling or "B" output in Heating can be selected. On = O; Off = B.

**SW2-4** Access Relay Operation (P2)  
**and 2-5**

Access Relay Operation	SW2-4	SW2-5
Cycle with Blower	ON	ON
Cycle with Compressor	OFF	OFF
Water Valve Slow Opening	ON	OFF
Cycle with Comm. T-stat Hum Cmd	OFF	ON

## Controls cont.

**Cycle with Blower** - The accessory relay will cycle with the blower output.

**Cycle with Compressor** - The accessory relay will cycle with the compressor output.

**Water Valve Slow Opening** - The accessory relay will cycle and delay both the blower and compressor output for 90 seconds.

**SW2-6** CC Operation - selection of single or dual capacity compressor. On = Single Stage; Off = Dual Capacity

**SW2-7** Lockout and Alarm Outputs (P2) - selection of a continuous or pulsed output for both the LO and ALM Outputs. On = Continuous; Off = Pulsed

**SW2-8** Future Use

### Alarm Jumper Clip Selection

From the factory, ALM is connected to 24 VAC via JW2. By cutting JW2, ALM becomes a dry contact connected to ALG.

### Variable Speed ECM Blower Speeds

The blower speeds can be changed either by using the ECM manual configurations mode method or by using the Aurora AID Tool directly (see Instruction Guide: Aurora Interface and Diagnostics (AID) Tool topic).

## Field Selectable Options via Software

(Selectable via the Aurora AID Tool)

### ECM Blower Speeds

An ECM blower motor can be driven directly using the onboard PWM output. Four blower speeds are available, based upon the "G", Y1 (low), Y2 (high), and Aux input signals to the board. The blower speeds can be changed either by the ECM manual configurations mode method (see ECM Configuration Mode topic) or by using the Aurora AID Tool directly. All four blower speeds can be set to the same speed if desired. Aux blower speed will remain at default or current setting and requires the AID Tool for adjustment.

## Safety Features

The following safety features are provided to protect the compressor, heat exchangers, wiring and other components from damage caused by operation outside of design conditions.

**Fuse** - a 3 amp automotive type plug-in fuse provides protection against short circuit or overload conditions.

**Anti-Short Cycle Protection** - 4 minute anti-short cycle protection for the compressor.

**Random Start** - 5 to 80 second random start upon power up.

**Fault Retry** - in the fault condition, the control will stage off the outputs and then "try again" to satisfy the thermostat Y input call. Once the thermostat input calls are satisfied, the control will continue on as if no fault occurred. If 3 consecutive faults occur without satisfying the thermostat Y input call, then the control will go to Lockout mode.

**Lockout** - when locked out, the blower will operate continuously in "G" speed, and PSC blower motor output will remain on. The Alarm output (ALM) and Lockout output (L) will be turned on. The fault type identification display LED1 (Red) shall flash the fault code. To reset lockout conditions with SW2-8 On, thermostat inputs "Y1", "Y2", and "W" must be removed for at least 3 seconds. To reset lockout conditions with SW2-8 Off, thermostat inputs "Y1", "Y2", "W", and "DH" must be removed for at least 3 seconds. Lockout may also be reset by turning power off for at least 30 seconds or by enabling the emergency shutdown input for at least 3 seconds.

**Lockout With Emergency Heat** - if the control is locked out in the heating mode, and a Y2 or W input is received, the control will operate in the emergency heat mode while the compressor is locked out. The first emergency heat output will be energized 10 seconds after the W input is received, and the blower will shift to high speed. If the control remains locked out, and the W input is present, additional stage of emergency heat will stage on after 2 minutes. When the W input is removed, all of the emergency heat outputs will turn off, and the ECM blower will shift to "G" speed and PSC blower motor output will remain on.

**High Pressure** - fault is recognized when the Normally Closed High Pressure Switch, P4-9/10 opens, no matter how momentarily. The High Pressure Switch is electrically in series with the Compressor Contactor and serves as a hard-wired limit switch if an overpressure condition should occur.

**Low Pressure** - fault is recognized when the Normally Closed Low Pressure Switch, P4-7/8 is continuously open for 30 seconds. Closure of the LPS any time during the 30 second recognition time restarts the 30 second continuous open requirement. A continuously open LPS shall not be recognized during the 2 minute startup bypass time.

**Loss of Charge** - fault is recognized when the Normally Closed Low Pressure Switch, P4-7/8 is open prior to the compressor starting.

**Condensate Overflow** - fault is recognized when the impedance between this line and 24 VAC common or chassis ground drops below 100K ohms for 30 seconds continuously.

**Freeze Detection (Coax)** - set points shall be either 30°F or 15°F. When the thermistor temperature drops below the selected set point, the control shall begin counting down the 30 seconds delay. If the thermistor value rises above the selected set point, then the count should reset. The resistance value must remain below the selected set point for the entire length of the appropriate delay to be recognized as a fault. This fault will be ignored for the initial 2 minutes of the compressor run time.

**Freeze Detection (Air Coil)** - uses the FP2 input to protect against ice formation on the air coil. The FP2 input will operate exactly like FP1 except that the set point is 30 degrees and is not field adjustable.

## Controls cont.

**Over/Under Voltage Shutdown** - An over/under voltage condition exists when the control voltage is outside the range of 18 VAC to 30 VAC. If the over/under voltage shutdown lasts for 15 minutes, the lockout and alarm relay will be energized. Over/under voltage shutdown is self-resetting in that if the voltage comes back within range of 18 VAC to 30 VAC for at least 0.5 seconds, then normal operation is restored.

### Operation Description

**Power Up** - The unit will not operate until all the inputs and safety controls are checked for normal conditions. The unit has a 5 to 80 second random start delay at power up. Then the compressor has a 4 minute anti-short cycle delay after the random start delay.

**Standby** In standby mode, Y1, Y2, W, DH, and G are not active. Input O may be active. The blower and compressor will be off.

### Heating Operation

#### **Single Compressor Heating, 2nd Stage (Y1, Y2)**

The compressor will be staged to full capacity 20 seconds after Y2 input is received. The ECM blower will shift to high speed seconds after the Y2 input is received.

#### **Dual Compressor Heating, 2nd Stage (Y1, Y2)**

In dual compressor operation, two ABC boards used in 24 VAC operation, there will be a Y2 call to the Y1 input on the second ABC. The compressor will stage to full capacity 30 seconds after Y1 input is received to the second board.

#### **Single Compressor Heating, 3rd Stage (Y1, Y2, W)**

The hot water pump is de-energized and the first stage of electric heat is energized 10 seconds after the W command is received. If the demand continues the second stage of electric heat will be energized after 5 minutes.

#### **Dual Compressor Heating, 3rd Stage (Y1, Y2, W) -**

The first stage of electric heat is energized 10 seconds after the W command is received. If the demand continues the second stage of electric heat will be energized after 5 minutes

**Emergency Heat (W)** - The blower will be started on "G" speed, 10 seconds later the first stage of electric heat will be turned on. 5 seconds after the first stage of electric heat is energized the blower will shift to Aux speed. If the emergency heat demand is not satisfied after 2 minutes the second electric heat stage will be energized.

**Blower (G)** - The blower will start immediately upon receiving a thermostat G command. If there are no other commands from the thermostat the ECM will run on "G" speed until the G command is removed. Regardless of blower input (G) from the thermostat, the blower will remain on for 30 seconds at the end of each heating cycle.

### Cooling Operation

In all cooling operations, the reversing valve directly tracks the O input. Thus, anytime the O input is present, the reversing valve will be energized.

#### **Single Compressor Cooling, 2nd Stage (Y1, Y2, O)**

The compressor will be staged to full capacity 20 seconds after Y2 input was received. The ECM blower will shift to high speed 15 seconds after the Y2 input was received.

#### **Dual Compressor Cooling, 2nd Stage (Y1, Y2, O)**

In dual compressor operation, two ABC boards used in 24 VAC operation, there will be a Y2 call to the Y1 input on the second ABC. The compressor will stage to full capacity 30 seconds after Y1 input is received to the second board.

**Blower (G)** - The blower will start immediately upon receiving a thermostat G command. If there are no other commands from the thermostat the ECM will run on "G" speed until the G command is removed. Regardless of blower input (G) from the thermostat, the blower will remain on for 30 seconds at the end of each heating, cooling, and emergency heat cycle.

**Dehumidification (Y1, O, DH or Y1, Y2, O, DH)** - When a DH command is received from the thermostat during a compressor call for cooling the ECM blower speed will be reduced by 15% to increase dehumidification.

**Emergency Shutdown** - Four (4) seconds after a valid ES input, P2-7 is present, all control outputs will be turned off and remain off until the emergency shutdown input is no longer present. The first time that the compressor is started after the control exits the emergency shutdown mode, there will be an anti-short cycle delay followed by a random start delay. Input must be tied to common to activate.

**Continuous Blower Operation** - The blower output will be energized any time the control has a G input present, unless the control has an emergency shutdown input present. The blower output will be turned off when G input is removed.

**Load Shed** - The LS input disables all outputs with the exception of the blower output. When the LS input has been cleared, the anti-short cycle timer and random start timer will be initiated. Input must be tied to common to activate.

## Controls cont.

### Aurora ‘Base’ Control LED Displays

These three LEDs display the status, configuration, and fault codes for the control. These can also be read in plain English via the Aurora AID Tool.

#### Status LED (LED3, Green)

Description of Operation	Fault LED, Green
Normal Mode	ON
Control is Non-functional	OFF
Test Mode	Slow Flash
Lockout Active	Fast Flash
Dehumidification Mode	Flash Code 2
(Future Use)	Flash Code 3
(Future Use)	Flash Code 4
Load Shed	Flash Code 5
ESD	Flash Code 6
(Future Use)	Flash Code 7

#### Configuration LED (LED2, Yellow)

Description of Operation	Configuration LED, Yellow
No Software Overwritten	Flashing ECM Setting
DIP Switch was Overwritten	Slow Flash
ECM Configuration Mode	Fast Flash

#### Fault LED (LED1, Red)

Red Fault LED	LED Flash Code*	Lockout	Reset/Remove
Normal - No Faults	OFF	-	
Fault - Input	1	No	Auto
Fault - High Pressure	2	Yes	Hard or Soft
Fault - Low Pressure	3	Yes	Hard or Soft
Fault - Freeze Detection FP2	4	Yes	Hard or Soft
Fault - Freeze Detection FP1	5	Yes	Hard or Soft
Fault - Condensate Overflow	7	Yes	Hard or Soft
Fault - Over/Under Voltage	8	No	Auto
Fault - FP1 & FP2 Sensor Error	11	Yes	Hard or Soft

**NOTE:** All codes >11 use long flash for tens digit and short flash for the ones digit. 20, 30, 40, 50, etc. are skipped.

### Aurora Interface and Diagnostics (AID) Tool

The Aurora Interface and Diagnostics (AID) Tool is a device that is a member of the Aurora network.

The AID Tool is used to troubleshoot equipment which uses the Aurora control via Modbus RTU communication. The AID Tool provides diagnostics, fault management, ECM setup, and system configuration capabilities to the Aurora family of controls. An AID Tool is recommended, although not required, for ECM airflow settings. The AID Tool simply plugs into the exterior of the cabinet in the AID Tool port.



### ABC Control Board Layout

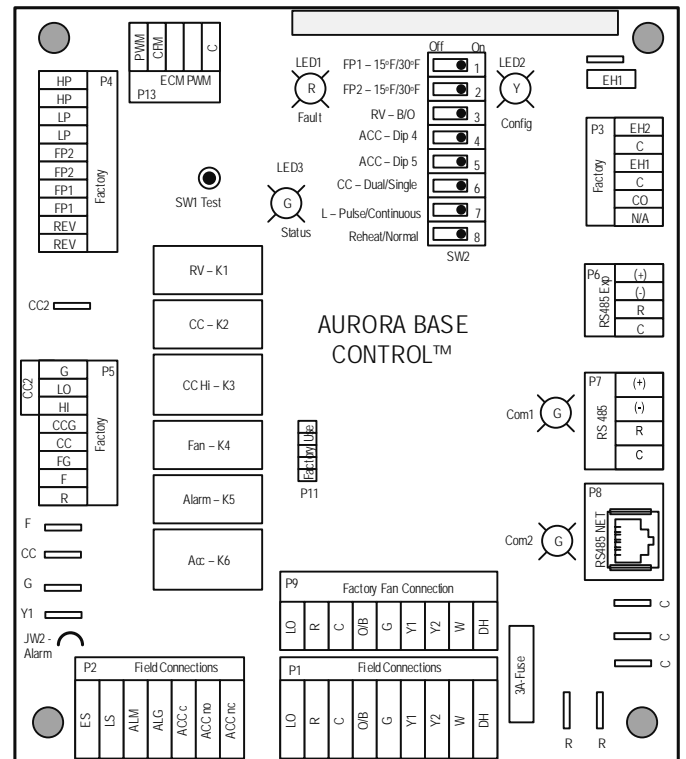

## Controls cont.

### Aurora ‘Advanced’ Control Features

The Aurora ‘Advanced’ Control system expands on the capability of the Aurora ‘Base’ Control (ABC) by adding the Aurora Expansion Board (AXB). All of the preceding features of the Aurora ‘Base’ Control are included. The following control description is of the additional features and capability of the Aurora advanced control.

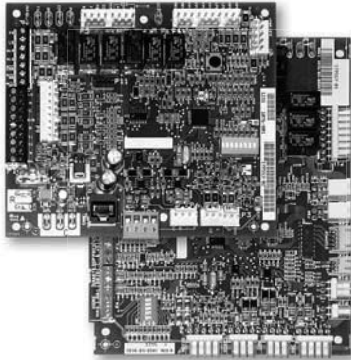

It is highly recommended the installing/servicing contractor obtain an Aurora Interface and Diagnostic Tool (AID) and specialized training before attempting to install or service an Aurora ‘Advanced’ control system.



The additional AXB features include the following:

#### AXB DIP Switch

**DIP 1 - ID:** This is the AXB ModBus ID and should always read On.

#### DIP 2 & 3 - Future Use

**DIP 4 & 5 - Accessory Relay2:** A second, DIP configurable, accessory relay is provided that can be cycled with the compressor 1 or 2, blower, or the Dehumidifier (DH) input. This is to complement the Accessory 1 Relay on the ABC board.

Position	DIP 4	DIP 5	Description
1	ON	ON	Cycles with Fan or ECM (or G)
2	OFF	ON	Cycles with CC1 first stage of compressor or compressor spd 6
3	ON	OFF	Cycles with CC2 second stage of compressor or compressor spd 7-12
4	OFF	OFF	Cycles with DH input from ABC board

### Advanced Hot Water Generator Control (Domestic Hot Water Option)

In lieu of the ‘Base Hot Water Generator Control’, the Advanced features an AID Tool selectable temperature limit and microprocessor control of the process. This will maximize hot water generation and prevent undesirable energy use. An alert will occur when the hot water input temperature is at or above setpoint (100°F - 140°F) for 30 continuous seconds (130°F is the default setting). This alert will appear as an E15 on the AID Tool and the hot water pump de-energizes. Hot water pump operations resume on the next compressor cycle or after 15 minutes of continuous compressor operation during

the current thermostat demand cycle. Since compressor hot gas temperature is dependent on loop temperature in cooling mode, loop temperatures may be too low to allow proper heating of water. The control will monitor water and refrigerant temperatures to determine if conditions are satisfactory for heating water. LED1 (red LED) will flash code 15 when the DHW limit is reached and when conditions are not favorable for water heating. Error code 15 will also be displayed on the AID Tool in the fault screen. This flash code is a noncritical alert and does not necessarily indicate a problem.

### Compressor Monitoring

The AXB includes two current transducers to monitor the compressor current and starting characteristics. Open circuits or welded contactor faults will be detected. A fault will produce an E10 code.

### IntelliZone2 Zoning Compatibility (Optional IntelliZone2 Zoning)

A dedicated input to connect and communicate with the IntelliZone2 (IZ2) zoning system is provided on P7. The is a dedicated communication port using a proprietary ModBus protocol. An AXB can be added to other selected ABC-only systems as well. Then an advanced communicating IntelliZone2 zoning system can be added to ABC-only systems. Consult the IntelliZone2 literature for more information.

### Variable Speed Pump

This input and output are provided to drive and monitor a variable speed pump. The VS pump output is a PWM signal to drive the variable speed pump. The minimum and maximum level are set using the AID Tool. 75% and 100% are the default settings respectively. The VS data input allows a separate PWM signal to return from the pump giving fault and performance information. Fault received from the variable speed pump will be displayed as E16.

### Modulating Water Valve

This output is provided to drive a modulating water valve. Through advanced design the 0-10VDC valve can be driven directly from the VS pump output. The minimum and maximum level are set in the same way as the VS pump using the AID Tool. 75% and 100% are the default settings respectively.

### Loop Pump Linking

This input and output are provided so that two units can be linked together with a common flow center. When either unit has a call for loop pump, both unit’s loop pump relays and variable speed pumps are energized. The flow center then can simply be wired to either unit. The output from one unit should be routed to the input of the other. If daisy chained up to 16 heat pumps can be wired and linked together in this fashion.

## Controls cont.

### Advanced Communication Ports

Communication ports P6 and P8 will provide future expansion via dedicated protocols. These are for future use.

### Smart Grid-On Peak (SG) Input

The 'On Peak' input was designed to allow utilities to utilize simple radio controlled switches to control the On Electric Peak behavior of the 5 and 7 Series Geothermal Heat Pumps. With a closed contact signal, this input will limit the operation and thus the power consumption of the unit by one of the below selections. The AID Tool will allow configuration of this input for the action of:

- No Action
- Disable compressor operation until removed
- Go to On Peak thermostat settings until removed [Requires Com T-Stat] (Future Release)
- Compressor limited to 50% or low cap until removed [dual capacity or variable speed only] (Future Release)
- Disable compressor operation for 1/2 hr (can be removed immediately) (Future Release)

Then Flash Code 7 on the Green LED for the 'On Peak' mode. And On Peak will display on communicating thermostats.

### Home Automation 1 and 2 Inputs

The Home automation inputs are simple closed contact inputs that will trigger an AID Tool and thermostat alert for the homeowner. These would require optional sensors and or equipment for connection to the AXB board. With two inputs two different sensors can be selected. The selected text will then be displayed on the AID Tool and communicating thermostats. These events will NOT alter functionality or operation of the heat pump/accessories and is for homeowner/service notification only.

#### Home Automation 1 - E23 HA1

With a closed dry contact signal, this input will cause an alarm and Alert Code 23 to indicate on the stat or flash on ABC. The AID Tool will allow configuration of this input between the following selections:

- No Action
- Home Automation Fault [no lockout info only]
  - Output from home automation system
- Security Alarm [no lockout info only]
  - Output from home security
- Sump Alarm Fault [no lockout info only]
  - Switch output from sump sensor
- Smoke/CO Alarm Fault [no lockout info only]
  - Switch output from Smoke/CO sensor
- Dirty Filter Alarm [no lockout info only]
  - Output from dirty filter sensor

#### Home Automation 2 - E24 HA2

With a closed dry contact signal, this input will cause an alarm and Alert Code 24 to indicate on the stat or flash on ABC. The AID Tool will allow configuration of this input between the following selections:

- No Action
- Home Automation Fault [no lockout info only]
  - Output from home automation system
- Security Alarm [no lockout info only]
  - Output from home security
- Sump Alarm Fault [no lockout info only]
  - Switch output from sump sensor
- Smoke/CO Alarm Fault [no lockout info only]
  - Switch output from Smoke/CO sensor
- Dirty Filter Alarm [no lockout info only]
  - Output from dirty filter sensor

## Monitoring Sensor Kits

### Energy Monitoring

#### (Standard Sensor Kit on 'Advanced' models)

The Energy Monitoring Kit includes two current transducers (blower and electric heat) added to the existing two compressor sensors so that the complete power usage of the heat pump can be measured. The AID Tool provides configuration detail for the type of blower motor and a line voltage calibration procedure to improve the accuracy. This information can be displayed on the AID Tool or selected communicating thermostats. The TPCM32U03/04 will display instantaneous energy use while the color touchscreen TPCC32U01 will in addition display a 13 month history in graph form.

### Refrigerant Monitoring (optional sensor kit)

The optional Refrigerant Monitoring Kit includes two pressure transducers, and three temperature sensors, heating liquid line, suction temperature and existing cooling liquid line (FP1). These sensors allow the measurement of discharge and suction pressures, suction and liquid line temperatures as well as superheat and subcooling. This information will only be displayed on the AID Tool.

### Performance Monitoring (optional sensor kit)

The optional Performance Monitoring Kit includes three temperature sensors, entering and leaving water, leaving air temperature and a water flow rate sensor. With this kit heat of extraction and rejection will be calculated. This requires configuration using the AID Tool for selection of water or antifreeze.

## Controls cont.

### Special Modes and Applications

#### 5-Speed ECM Blower Motor

Normally the 5-Speed ECM motor can be driven off of thermostat signals and the ABC connector P9.

Communicating thermostats, however present a special problem in this application since they operate without 24 VAC thermostat signals. The ABC board is wired to operate these systems from the alternate relay output signals CC1, CC2, Fan, and EH1 and should be wired for this.

#### Communicating Digital Thermostats

The Aurora controls system also features either monochromatic or color touch screen graphic display thermostats for user interface. These displays not only feature easy to use graphical interface but display alerts and faults in plain English. Many of the features discussed here may not be applicable without these thermostats.

#### Dehumidification - Passive

In passive dehumidification mode, the airflow is reduced by 15% from the heating airflow setting. If cooling airflow is set to +5, -5 or -10% of heating airflow it will automatically be set to -15% of heating airflow whenever the dehumidification call is present in the communicating stat or from the thermostat input DH. If the airflow for cooling is already set to -15% no airflow change will be noticed from normal cooling. Dehumidification mode will be shown on the ABC and the communicating thermostats.

### Aurora 'Advanced' Control LED Displays

These three LEDs display the status, configuration, and fault codes for the control. These can also be read in plain English via the Aurora AID Tool.

#### Status LED (LED3, Green)

Description of Operation	Fault LED, Green
Normal Mode	ON
Control is Non-functional	OFF
Test Mode	Slow Flash
Lockout Active	Fast Flash
Dehumidification Mode	Flash Code 2
Load Shed	Flash Code 5
Emergency Shutdown	Flash Code 6
On Peak Mode	Flash Code 7
(Future Use)	Flash Code 8
(Future Use)	Flash Code 9

#### Configuration LED (LED2, Yellow)

Description of Operation	Configuration LED, Yellow
No Software Overwritten	ECM Setting
DIP Switch Overwritten	Slow Flash
ECM Configuration Mode	Fast Flash
Reset Configuration Mode	OFF

#### Fault LED (LED1, Red)

Red Fault LED	LED Flash Code *	Lockout	Reset/Remove	Fault Condition Summary	
Normal - No Faults	Off	-			
ABC Basic Faults	Fault-Input	1	No	Auto	Tstat input error. Autoreset upon condition removal.
	Fault-High Pressure	2	Yes	Hard or Soft	HP switch has tripped (>600 psi)
	Fault-Low Pressure	3	Yes	Hard or Soft	Low Pressure Switch has tripped (<40 psi for 30 continuous sec.)
	Fault-Freeze Detection FP2	4	Yes	Hard or Soft	Freeze protection sensor has tripped (<15 or 30 degF for 30 continuous sec.)
	Fault-Freeze Detection FP1	5	Yes	Hard or Soft	Freeze protection sensor has tripped (<15 or 30 degF for 30 continuous sec.)
	Fault-Condensate Overflow	7	Yes	Hard or Soft	Condensate switch has shown continuity for 30 continuous sec.
	Fault-Over/Under Voltage	8	No	Auto	Instantaneous voltage is out of range. **Controls shut down until resolved.
	Fault-FP1 & 2 Snsr Error	11	Yes	Hard or Soft	If FP1 or 2 Sensor Error
ABC & AXB Advanced Faults	Fault-Compressor Monitor	10	Yes	Hard or Soft	Open Crkt, Run, Start or welded cont
	Non-CriticAXBSnsrErr	13	No	Auto	Any Other Sensor Error
	CriticAXBSnsrErr	14	Yes	Hard or Soft	Sensor Error for EEV or HW
	Alert-HotWtr	15	No	Auto	HW over limit or logic lockout. HW pump deactivated.
	Fault-VarSpdPump	16	No	Auto	Alert is read from PWM feedback.
	Not Used	17	No	Auto	IZ2 Com Fault. Autoreset upon condition removal.
	Non-CritComErr	18	No	Auto	Any non-critical com error
	Fault-CritComErr	19	No	Auto	Any critical com error. Auto reset upon condition removal
	Alarm - Low Loop Pressure	21	No	Auto	Loop pressure is below 3 psi for more than 3 minutes
	Alarm - Home Automation 1	23	No	Auto	Closed contact input is present on Dig 2 input - Text is configurable
Alarm - Home Automation 2	24	No	Auto	Closed contact input is present on Dig 3 input - Text is configurable	

**NOTES:**

\*All codes >11 use long flash for tens digit and short flash for the ones digit. 20, 30, 40, 50 etc. are skipped!

Alert' is a noncritical sensor or function that has failed. Normal operation of the heat pump is maintained but service is desired at some point.



## Application Notes

### The Closed Loop Heat Pump Concept

The basic principle of a water source heat pump is the transfer of heat into water from the space during cooling, or the transfer of heat from water into the space during heating. Extremely high levels of energy efficiency are achieved as electricity is used only to move heat, not to produce it. Using a typical Affinity Console Series, one unit of electricity will move four to five units of heat.

When multiple water source heat pumps are combined on a common circulating loop, the ultimate in energy efficiency is created: Units on cooling mode are adding heat to the loop which the units in heating mode can absorb, thus removing heat from the area where cooling is needed, recovering and redistributing that heat for possible utilization elsewhere in the system. In modern commercial structures, this characteristic of heat recovery from core area heat generated by lighting, office equipment, computers, solar radiation, people or other sources, is an important factor in the high efficiency and low operating costs of closed source heat pump systems.

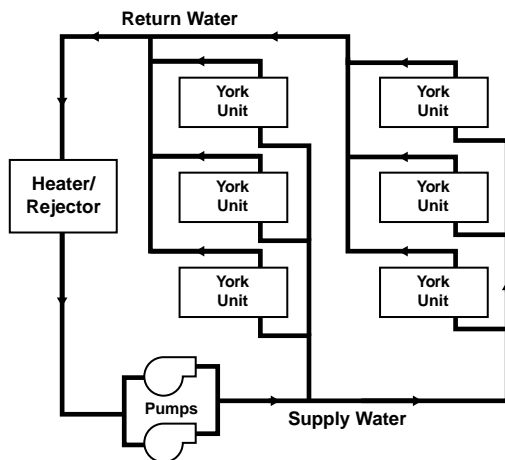

In the event that a building's net heating and cooling requirements create loop temperature extremes, Affinity Console Series units have the extended range capacity and versatility to maintain a comfortable environment for all building areas. Excess heat can be stored for later utilization or be added or removed in one of three ways; by ground-source heat exchanger loops: plate heat exchangers connected to other water sources, or conventional cooler/boiler configurations. Your representative has the expertise and computer software to assist in determining optimum system type for specific applications.

### The Closed Loop Advantage

A properly applied water source heat pump system offers many advantages over other systems. First costs are low because units can be added to the loop on an "as needed basis"- perfect for speculative buildings. Installed costs are low since units are self-contained and can be located adjacent to the occupied space, requiring minimal ductwork. Maintenance can be done on individual

units without system shut-down. Conditions remain comfortable since each unit operates separately, allowing cooling in one area and heating in another. Tenant spaces can be finished and added as needed. Power billing to tenants is also convenient since each unit can be individually metered: each pays for what each uses. Nighttime and/or weekend uses of certain areas are possible without heating or cooling the entire facility. A decentralized system also means if one unit should fault, the rest of the system will continue to operate normally, as well as eliminating air cross-contamination problems and expensive high pressure duct systems requiring an inefficient electric resistance reheat mode.

### The Affinity Console Series Approach

There are a number of proven choices in the type of Affinity Console Series system which would be best for any given application. Most often considered are:

#### *Vertical - Closed Loop/Ground Source*

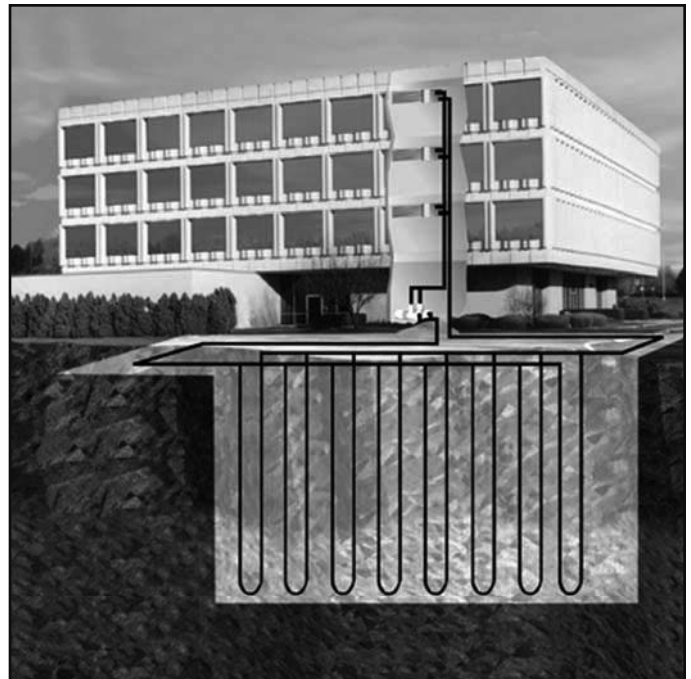

- **Closed Loop/Ground-Source Systems** utilize the stable temperatures of the earth to maintain proper water source temperatures (via vertical or horizontal closed loop heat exchangers) for Affinity Console Series extended range heat pump system. Sizes range from a single unit through many hundreds of units. When net cooling requirements cause closed loop water temperatures to rise, heat is dissipated into the cooler earth through buried high strength plastic pipe "heat exchangers." Conversely if net space heating demands cause loop heat absorption beyond that heat recovered from building core areas, the loop temperature will fall causing heat to be extracted from the earth. Due to the extended loop temperatures, AHRI/ISO 13256-1 Ground Loop Heat Pumps are required for this application.

## Application Notes cont.

Because auxiliary equipment such as a fossil fuel boiler and cooling tower are not required to maintain the loop temperature, operating and maintenance costs are very low.

Ground-source systems are most applicable in residential and light commercial buildings where both heating and cooling are desired, and on larger envelope dominated structures where core heat recovery will not meet overall heating loads. Both vertical and horizontally installed closed-loops can be used. The land space required for the "heat exchangers" is 100-250 sq. ft./ton on vertical (drilled) installations and 750-1500 sq. ft./ton for horizontal (trenched) installations. Closed loop heat exchangers can be located under parking areas or even under the building itself.

On large multi-unit systems, sizing the closed loop heat exchanger to meet only the net heating loads and assisting cooling loads with a closed circuit cooling tower may be the most cost effective choice.

### **Surface Water - Closed Loop/Ground Source**

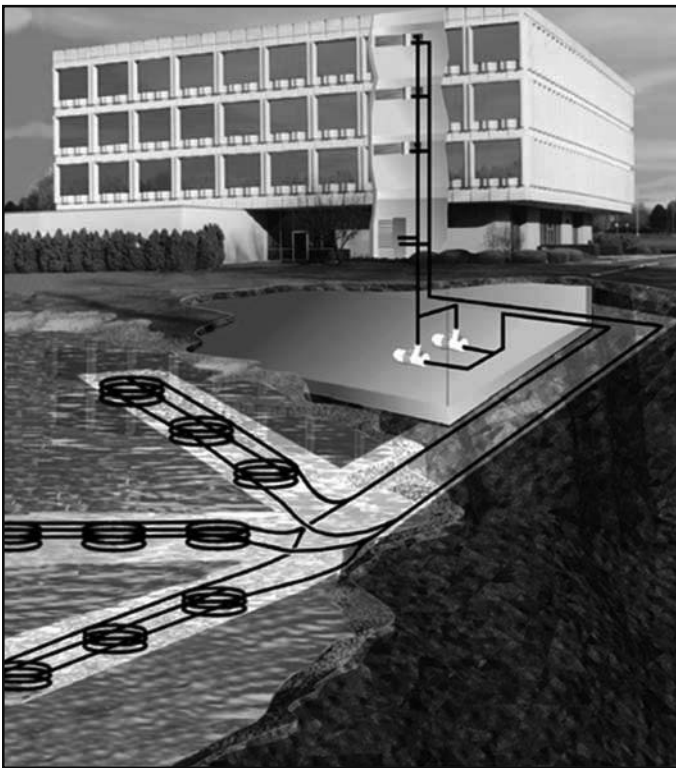

• **Closed Loop/Ground-Source Surface Water Systems** also utilize the stable temperatures of Surface Water to maintain proper water source temperatures for Affinity Console Series extended range heat pump systems. These systems have all of the advantages of horizontal and vertical closed loop systems. Due to the extended loop temperatures, AHRI/ISO 13256-1 Ground Water or Ground Loop Heat Pumps are required for this application.

In cooling dominated structures, the ground-source surface water systems can be very cost effective especially where local building codes require water retention ponds for short term storage of surface run-off. Sizing requirements for the surface water is a minimum of 500 sq. ft./ton of surface area at a minimum depth of 8 feet. York should be contacted when designs for heating dominated structures are required.

### **Plate Heat Exchanger - Closed Loop/Ground Water** •

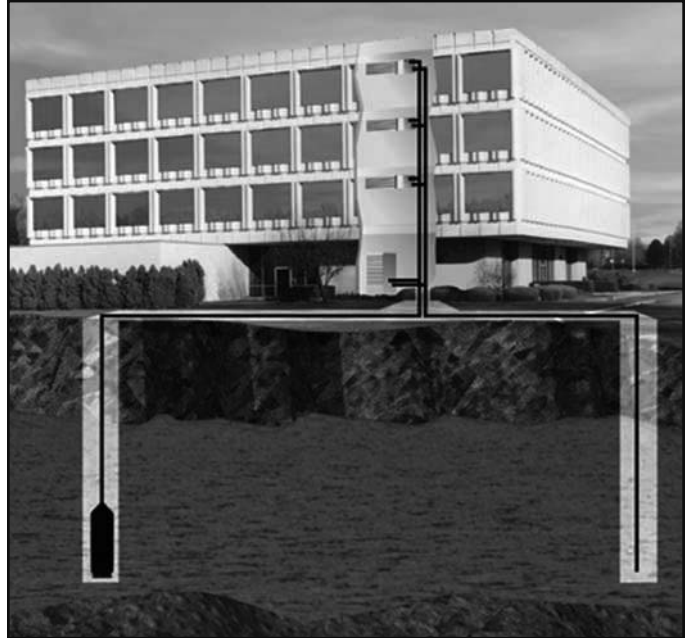

**Closed Loop/Ground Water Plate Heat Exchanger Systems** utilize lake, ocean, well water or other water sources to maintain closed loop water temperatures in multi-unit Affinity Console Series systems. A plate frame heat exchanger isolates the units from any contaminating effects of the water source, and allows periodic cleaning of the heat exchanger during off peak hours.

Operation and benefits are similar to those for ground-source systems. Due to the extended loop temperatures, AHRI/ISO 13256-1 Ground Loop Heat Pumps are required for this application. Closed loop plate heat exchanger systems are applicable in commercial, marine, or industrial structures where the many benefits of a water source heat pump system are desired, regardless of whether the load is heating or cooling dominated.

## Application Notes cont.

### *Cooler/Boiler - Closed Loop*

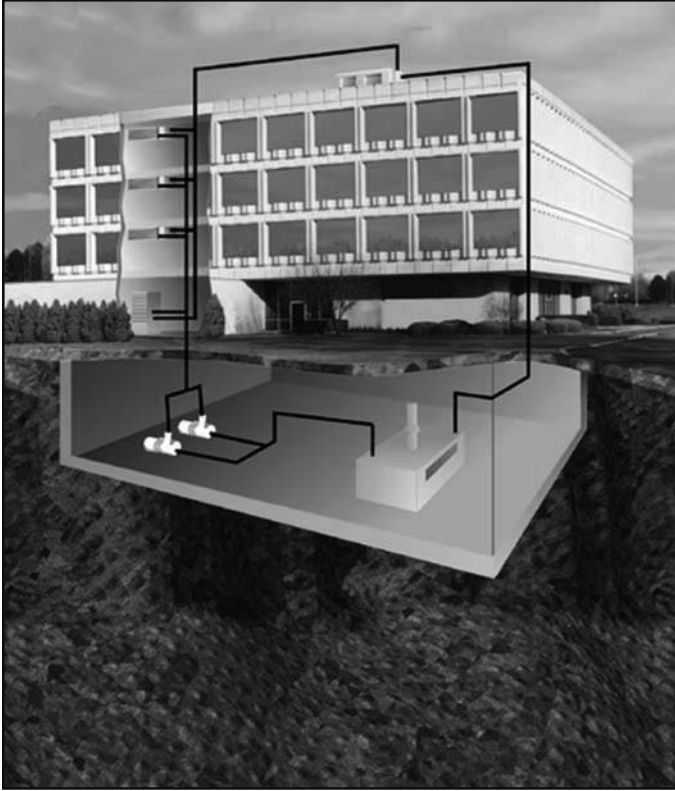

• **Closed Loop /Cooler-Boiler Systems** utilize a closed heat recovering loop with multiple water source heat pumps in the more conventional manner. Typically a boiler is employed to maintain closed loop temperatures above 60°r and a cooling tower to maintain loop temperatures below 90°F. These systems are applicable in medium to large buildings regardless of whether the load is heating or cooling dominated. Due to the moderate loop temperatures, AHRI/ISO 13256-1 Water Loop Heat Pumps are required for this application.

## Water Quality

In ground water situations where scaling could be heavy or where biological growth such as iron bacteria will be present, a closed loop system is recommended. The heat exchanger coils in ground water systems may, over a period of time, lose heat exchange capabilities due to a buildup of mineral deposits inside. These can be cleaned, but only by a qualified service mechanic, as special solutions and pumping equipment are required. Hot water generator coils can likewise become scaled and possibly plugged. In areas with extremely hard water, the owner should be informed that the heat exchanger may require occasional flushing.

Units with cupronickel heat exchangers are recommended for open loop applications due to the increased resistance to build-up and corrosion, along with reduced wear caused by acid cleaning. Failure to adhere to the guidelines in the water quality table could result in loss of warranty.

Material		Copper	90/10 Cupronickel	316 Stainless Steel
pH	Acidity/Alkalinity	7 - 9	7 - 9	7 - 9
Scaling	Calcium and Magnesium Carbonate	(Total Hardness) less than 350 ppm	(Total Hardness) less than 350 ppm	(Total Hardness) less than 350 ppm
Corrosion	Hydrogen Sulfide	Less than 0.5 ppm (rotten egg smell appears at 0.5 ppm)	10 - 50 ppm	Less than 1 ppm
	Sulfates	Less than 125 ppm	Less than 125 ppm	Less than 200 ppm
	Chlorine	Less than 0.5 ppm	Less than 0.5 ppm	Less than 0.5 ppm
	Chlorides	Less than 20 ppm	Less than 125 ppm	Less than 300 ppm
	Carbon Dioxide	Less than 50 ppm	10 - 50 ppm	10 - 50 ppm
	Ammonia	Less than 2 ppm	Less than 2 ppm	Less than 20 ppm
	Ammonia Chloride	Less than 0.5 ppm	Less than 0.5 ppm	Less than 0.5 ppm
	Ammonia Nitrate	Less than 0.5 ppm	Less than 0.5 ppm	Less than 0.5 ppm
	Ammonia Hydroxide	Less than 0.5 ppm	Less than 0.5 ppm	Less than 0.5 ppm
	Ammonia Sulfate	Less than 0.5 ppm	Less than 0.5 ppm	Less than 0.5 ppm
	Total Dissolved Solids (TDS)	Less than 1000 ppm	1000 - 1500 ppm	1000 - 1500 ppm
	LSI Index	+0.5 to -0.5	+0.5 to -0.5	+0.5 to -0.5
Iron Fouling (Biological Growth)	Iron, Fe <sup>2+</sup> (Ferrous) Bacterial Iron Potential	< 0.2 ppm	< 0.2 ppm	< 0.2 ppm
	Iron Oxide	Less than 1 ppm, above this level deposition will occur	Less than 1 ppm, above this level deposition will occur	Less than 1 ppm, above this level deposition will occur
Erosion	Suspended Solids	Less than 10 ppm and filtered for max. of 600 micron size	Less than 10 ppm and filtered for max. of 600 micron size	Less than 10 ppm and filtered for max. of 600 micron size
	Threshold Velocity (Fresh Water)	< 6 ft/sec	< 6 ft/sec	< 6 ft/sec

NOTES: Grains = ppm divided by 17  
mg/L is equivalent to ppm

2/22/12

## Installation Notes

### Typical Unit Installation Unit Location

Locate the unit in an indoor area that allows for easy removal of the filter and access panels. Location should have enough space for service personnel to perform maintenance or repair. Provide sufficient room to make water and electrical connection(s). Any access panel screws that would be difficult to remove after the unit is installed should be removed prior to setting the unit. **Care should be taken when units are located in unconditioned spaces to prevent damage from frozen water lines and excessive heat that could damage electrical components.**

### Installing Console Units

Console units are available in left or right air return configurations. Units should be mounted level on the floor. It is not necessary to anchor the unit to the floor.

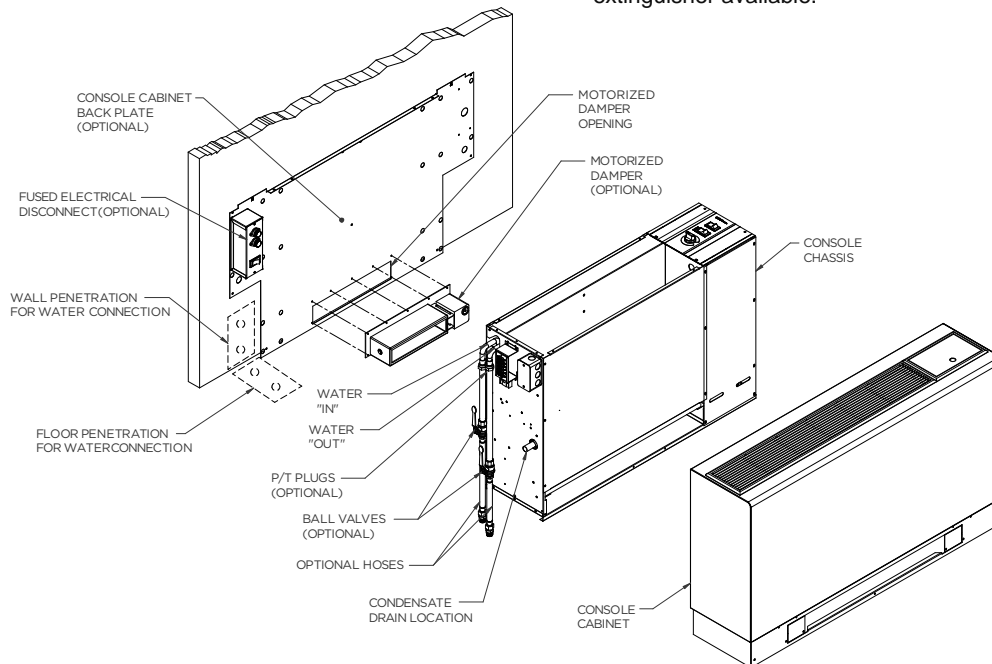

### Water Piping

Piping is usually design as 'reverse return' to equalize flow paths through each unit. A short flexible pressure rated hose is used to make connection to the fixed building piping system. This hose is typically stainless steel braid and includes a swivel fitting on one end for easy removal and is flexible to help isolate the unit for quieter operation. Isolation valves for servicing, y-strainers for filtering and memory-stop flow valve or a balancing valve can be provided for consistent water flow through the unit.

All unit source water connections are fittings that accept a male pipe thread (MPT). Insert the connectors by hand, then tighten the fitting with a wrench to provide a leakproof joint. The open and closed loop piping system should include pressure/temperature

**WARNING: Before performing service or maintenance operations on a system, turn off main power switches to the indoor unit. If applicable, turn off the accessory heater power switch. Electrical shock could cause personal injury.**

Installing and servicing heating and air conditioning equipment can be hazardous due to system pressure and electrical components. Only trained and qualified service personnel should install, repair or service heating and air conditioning equipment. Untrained personnel can perform the basic maintenance functions of cleaning coils and cleaning and replacing filters.

All other operations should be performed by trained service personnel. When working on heating and air conditioning equipment, observe precautions in the literature, tags and labels attached to the unit and other safety precautions that may apply. Follow all safety codes. Wear safety glasses and work gloves. Use a quenching cloth for brazing operations and have a fire extinguisher available.

ports for serviceability. The proper water flow must be provided to each unit whenever the unit operates. To assure proper flow, use pressure/temperature ports to determine the flow rate. These ports should be located at the supply and return water connections on the unit. The proper flow rate cannot be accurately set without measuring the water pressure drop through the refrigerant-to-water heat exchanger. Check carefully for water leaks.

### Condensate Drain

On console units, the internal condensate drain assembly consists of a drain tube which is connected to the drain pan. A condensate tube is inside all cabinets as a trapping loop; therefore, an external trap is not necessary.

## Selection Example

To achieve optimal performance, proper selection of each heat pump is essential. A building load program should be used to determine the heating and cooling load of each zone. A computer software selection program can then be used to develop an accurate and complete heat pump schedule. Software can be obtained from your local representative.

While a computer software program is the easiest and most accurate method to size and select equipment, however, selection can still be accomplished manually using this manual and the following selection procedure. Sizing so that the actual sensible capacity of the equipment will satisfy the sensible capacity of the zone is the recommended method for best results.

### Boiler/Tower Application

Typical boiler/tower application will result in entering water temperatures of 60-90°F with 70°F for heating and 90°F for cooling. Water to refrigerant insulation option would not be required. Flow rates are 2.5 to 3 gpm per ton with 2.5 gpm per ton often representing an economical design point.

### Geothermal Application

Typical geothermal application can result in a wide entering water temperature range of 30-100°F. Typically minimum heating entering water temperatures can range from 30 to 50°F depending upon loop type and geographical location. Cooling performance should be calculated using a maximum loop temperature of 100°F in most loop applications. Water flow is typically 2.5 to 3 gpm per ton with 3 gpm per ton recommended with the more extreme loop temperatures. **PLEASE NOTE THAT WATER COIL INSULATION OPTION SHOULD BE SELECTED WHEN ENTERING WATER TEMPERATURES ARE EXPECTED TO BE BELOW 45-50°F.**

### Geothermal Selection Example

**Step 1:** Determine the actual heating and cooling loads at the desired dry bulb and wet bulb conditions.

**Step 2:** Obtain the following design parameters: Entering water temperature, water flow rate in GPM, air flow in CFM, water flow pressure drop and design wet and dry bulb temperatures. Air flow CFM should be between 300 and 450 CFM per ton. Unit water pressure drop should be kept as close as possible to each other to make water balancing easier. Go to the appropriate tables and find the proper indicated water flow and water temperature.

**Step 3:** Select a unit based on total and sensible cooling conditions. Select a unit which is closest to, but no larger than, the actual cooling load.

**Step 4:** Enter tables at the design water flow and water temperature. Read the total and sensible cooling capacities (Note: interpolation is permissible, extrapolation is not).

**Step 5:** Read the heating capacity. If it exceeds the design criteria it is acceptable. It is quite normal for water source heat pumps to be selected on cooling capacity only since the heating output is usually greater than the cooling capacity.

**Step 6:** Determine the correction factors associated with the variable factors of dry bulb and wet bulb.

Corrected Total Cooling = tabulated total cooling x wet bulb correction.

Corrected Sensible Cooling = tabulated sensible cooling x wet/dry bulb correction.

**Step 7:** Compare the corrected capacities to the load requirements. Normally if the capacities are within 10% of the loads, the equipment is acceptable. It is better to undersize than oversize, as undersizing improves humidity control, reduces sound levels and extends the life of the equipment.

**Step 8:** When complete, calculate water temperature rise and assess the selection. If the units selected are not within 10% of the load calculations, then review what effect changing the GPM, water temperature and/or air flow and air temperature would have on the corrected capacities. If the desired capacity cannot be achieved, select the next larger or smaller unit and repeat the procedure. Remember, when in doubt, undersize slightly for best performance.

### Example Equipment Selection - Cooling

#### 1. Load Determination:

Assume we have determined that the appropriate cooling load at the desired dry bulb 75°F and wet bulb 60°F conditions is as follows:

Total Cooling..... 14,800 BTUH  
Sensible Cooling..... 11,200 BTUH  
Entering Air Temp .....75°F Dry Bulb / 60°F Wet Bulb

#### 2. Design Conditions:

Similarly, we have also obtained the following design parameters:  
Entering Water Temp ..... 100°F  
Water Flow (Based upon 10°F rise in temp.) 5.5 GPM  
Air Flow Required ..... 450 CFM

#### 3, 4 & 5. HP Selection:

After making our preliminary selection (YC18), we enter the tables at design water flow and water temperature and read

Total Cooling, Sens. Cooling and Heat of Rej. capacities:

Total Cooling..... 16,600 BTUH  
Sensible Cooling..... 12,600 BTUH  
Heat of Rejection ..... 21,400 BTUH

#### 6 & 7. Entering Air and Airflow Corrections:

Next, we determine our correction factors. (Refer to Correction Factor Tables - Air Flow and Entering Air correction tables — using 450 cfm. or 450÷500 nom. = 90%).

Corrected Total Cooling = 16,600 x 0.982 x 0.897 = 14,622

Corrected Sens Cooling = 12,600 x 0.933 x 0.995 = 11,697

Corrected Heat of Reject = 21,400 x 0.980 x 0.895 = 18,770

#### 8. Water Temperature Rise Calculation & Assessment:

**NOTE:** 500 = parameters for water & 485 = parameters for antifreeze solutions to 30% weight.

## Selection Example cont.

When we compare the Corrected Total Cooling and Corrected Sensible Cooling figures with our load requirements stated in Step 1, we discover that our selection is within +10% of our sensible load requirement. Further more, we see that our Corrected Total Cooling figure is within 1,000 Btuh of the actual indicated load.

$$HR = 500 \times GPM \times (T_{in} - T_{out})$$

$$\frac{HR}{500 \times GPM} = (T_{in} - T_{out}) \text{ or } \Delta T \text{ Rise}$$

$$\frac{18,770}{500 \times 5.5} = 6.83 \text{ } ^\circ\text{F Rise}$$

## Antifreeze Corrections

Catalog performance can be corrected for antifreeze use. Please use the following table and note the example given.

Antifreeze Type	Antifreeze % by wt	Cooling Capacity	Heating Capacity	Pressure Drop
EWT - degF [DegC]		90 [32.2]	30 [-1.1]	30 [-1.1]
Water	0	1.000	1.000	1.000
Ethylene Glycol	10	0.991	0.973	1.075
	20	0.979	0.943	1.163
	30	0.965	0.917	1.225
	40	0.955	0.890	1.324
	50	0.943	0.865	1.419
Propylene Glycol	10	0.981	0.958	1.130
	20	0.969	0.913	1.270
	30	0.950	0.854	1.433
	40	0.937	0.813	1.614
	50	0.922	0.770	1.816
Ethanol	10	0.991	0.927	1.242
	20	0.972	0.887	1.343
	30	0.947	0.856	1.383
	40	0.930	0.815	1.523
	50	0.911	0.779	1.639
Methanol	10	0.986	0.957	1.127
	20	0.970	0.924	1.197
	30	0.951	0.895	1.235
	40	0.936	0.863	1.323
	50	0.920	0.833	1.399

**Warning:** Gray area represents antifreeze concentrations greater than 35% by weight and should be avoided due to the extreme performance penalty they represent.

## Antifreeze Correction Example

Antifreeze solution is Propylene Glycol 20% by weight. Determine the corrected heating and cooling performance at 30°F and 90°F respectively as well as pressure drop at 30°F for an Affinity Console Series YC\*18.

The corrected cooling capacity at 90°F would be: 17,100 MBtuh x 0.969 = 16,569 MBtuh

The corrected heating capacity at 30°F would be: 14,300 MBtuh x 0.913 = 13,056 MBtuh

The corrected pressure drop at 30°F and 5.5 GPM would be: 18.2 feet of head x 1.270 = 23.1 feet of head

# Dimensional Data - Flat Top Cabinet

YCW09-18

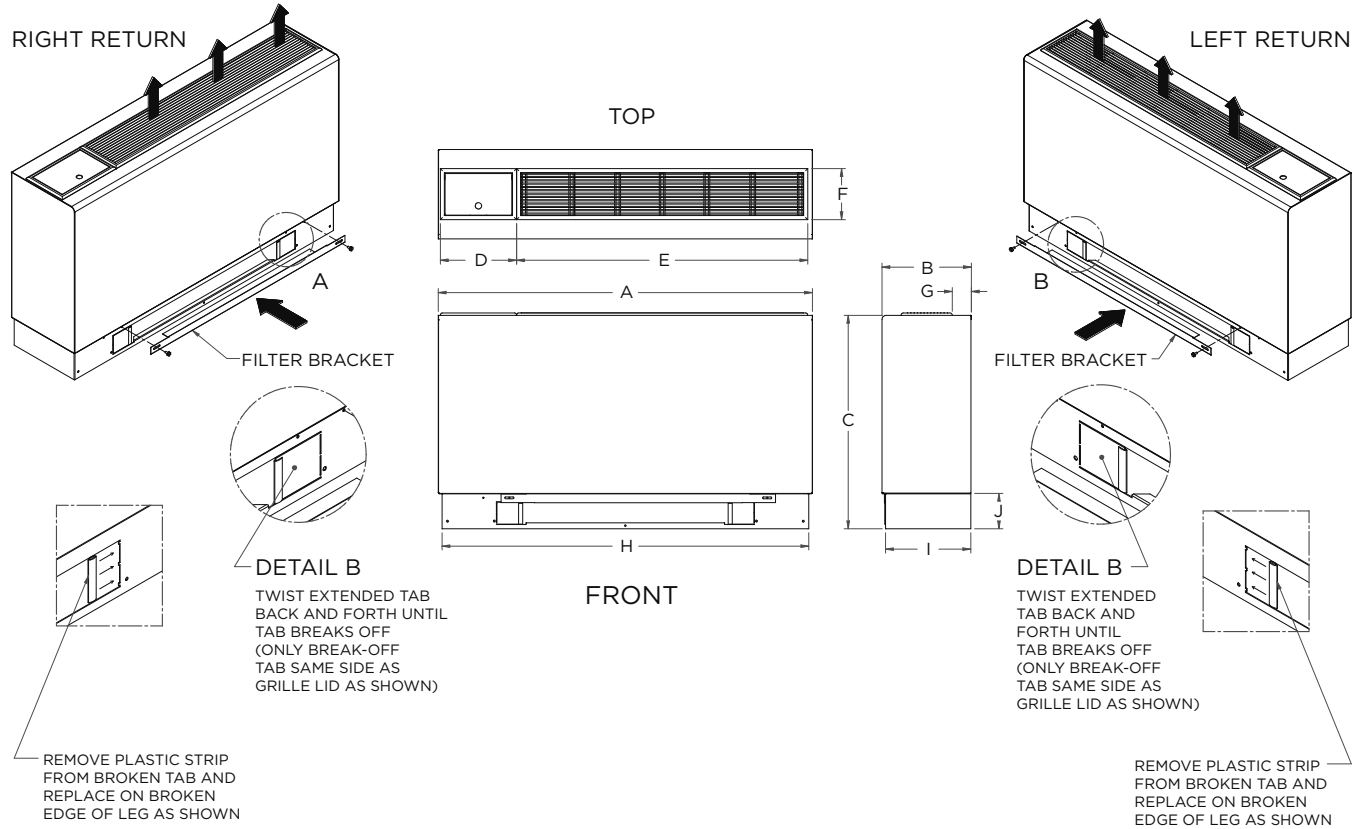

Flat Top Configuration		Overall Cabinet									
		A	B	C	D	E	F	G	H	I	J
		Width	Depth	Height	Grille Lid	Grille Length	Grille Width				
09-12	in.	45.0	10.8	25.7	9.2	35.0	6.1	2.3	44.1	10.3	4.3
	cm.	114.3	27.3	65.2	23.4	88.9	15.6	5.8	112.0	26.0	10.9
15-18	in.	50.0	12.3	25.7	9.2	35.0	6.1	3.3	49.1	11.8	4.3
	cm.	127.0	31.1	65.2	23.4	88.9	15.6	8.3	124.7	29.8	10.9



# Dimensional Data - Slope Top Cabinet

YCS09-18

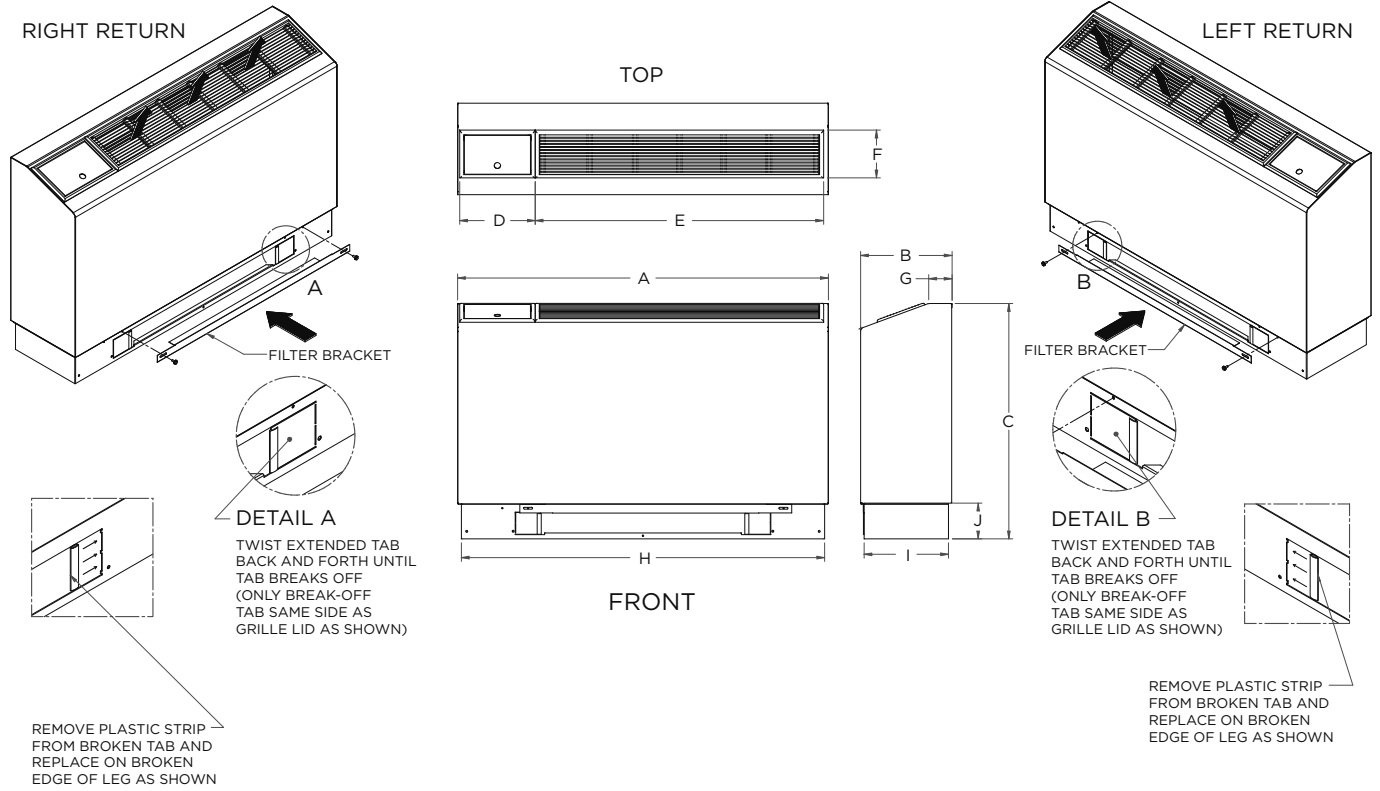

Slope Top Configuration		Overall Cabinet									
		A	B	C	D	E	F	G	H	I	J
		Width	Depth	Height	Grille Lid	Grille Length	Grille Width				
09-12	in.	45.0	11.1	28.6	9.2	35.0	6.1	2.8	44.1	10.3	4.3
	cm.	114.3	28.2	72.6	23.4	88.9	15.6	7.2	112.0	26.0	10.9
15-18	in.	50.0	12.6	29.1	9.2	35.0	6.1	2.5	49.1	11.8	4.3
	cm.	127.0	32.0	73.9	23.4	88.9	15.6	6.4	124.7	29.8	10.9

# Dimensional Data - Extended Slope Top Cabinet

YCE09-18

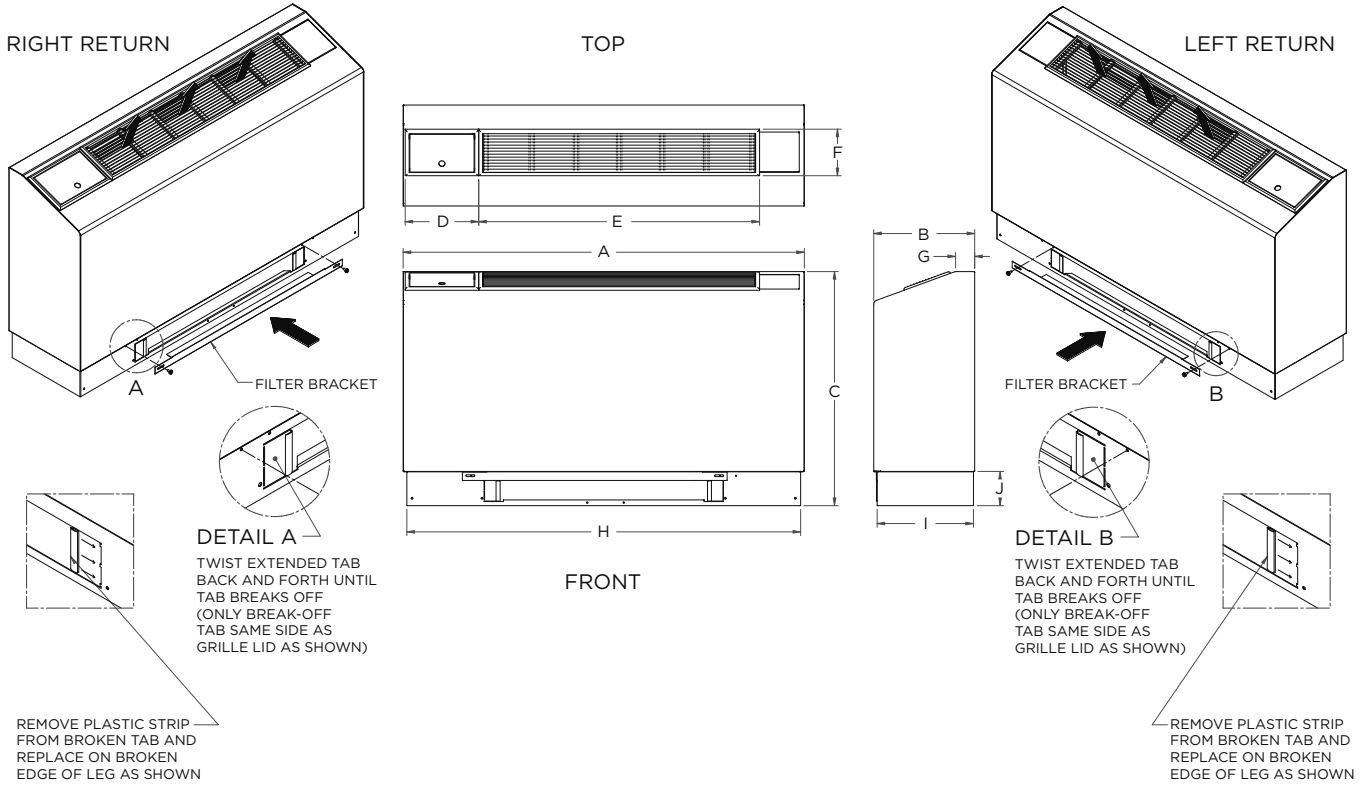

Ext. Slope Top Configuration		Overall Cabinet									
		A	B	C	D	E	F	G	H	I	J
		Width	Depth	Height	Grille Lid	Grille Length	Grille Width				
09-12	in.	50.0	12.6	29.1	9.2	35.0	6.1	2.4	49.1	12.0	4.3
	cm.	127.0	32.0	73.9	23.4	88.9	15.6	6.1	124.7	30.5	10.9
15-18	in.	55.0	12.6	29.1	9.2	35.0	6.1	2.5	54.1	11.8	4.3
	cm.	139.7	32.0	73.9	23.4	88.9	15.6	6.4	137.4	29.8	10.9

# Dimensional Data - Right Return Controls Detail

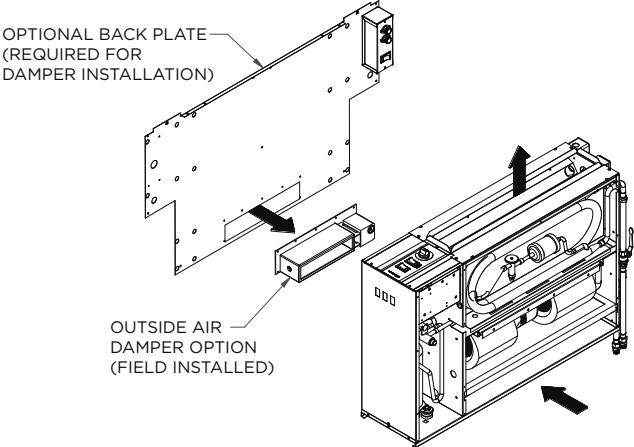
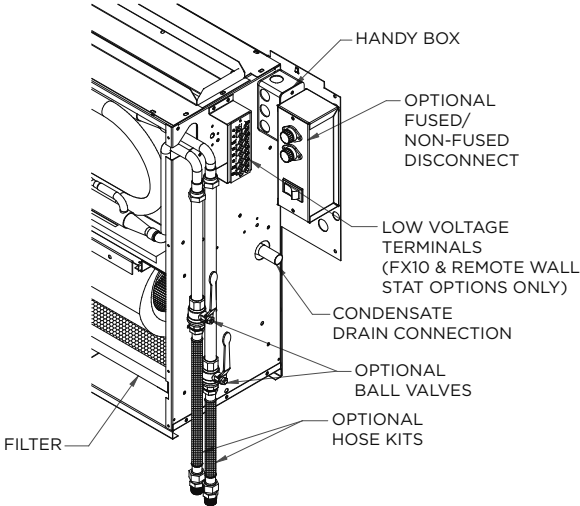
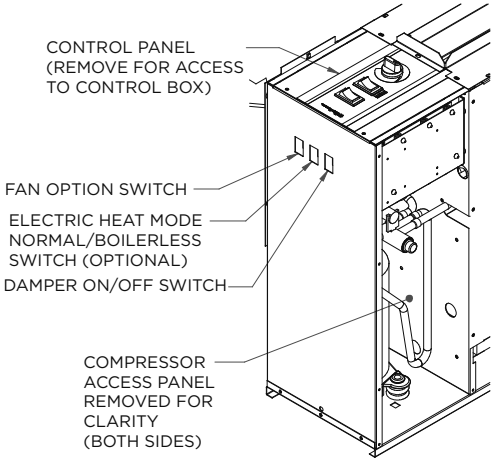

# Dimensional Data - Right Return Chassis

Data = inches (cm)

## Models 09-12

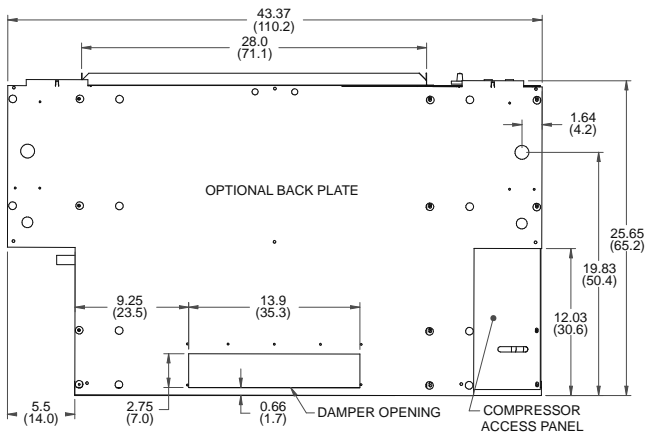
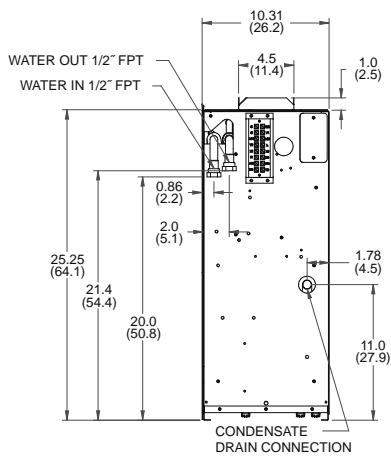
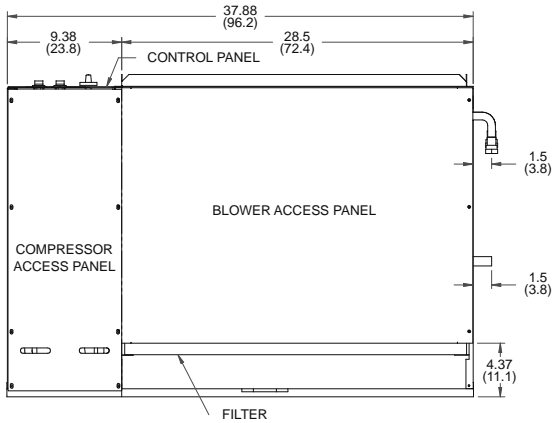

## Models 15-18

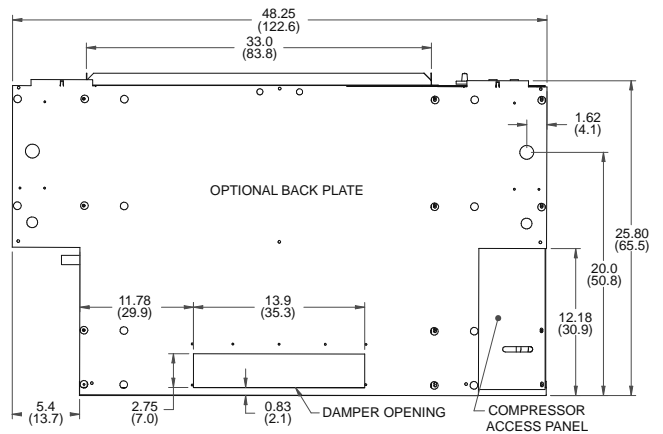
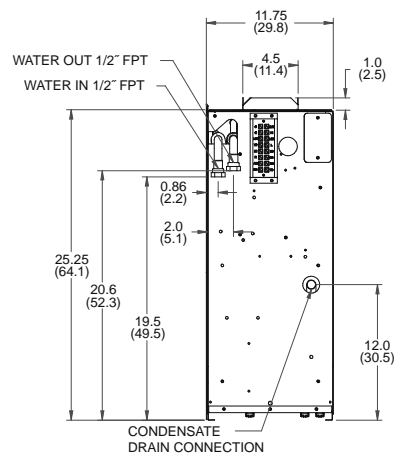
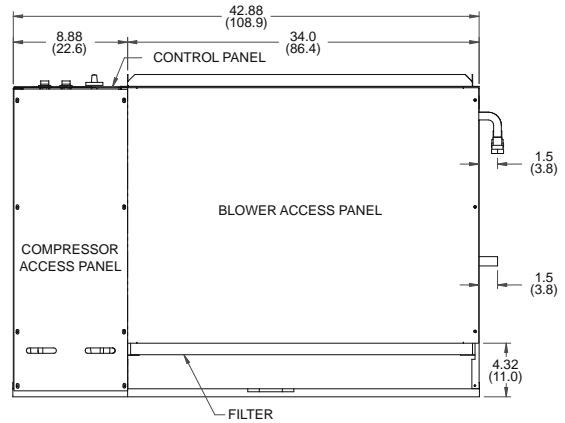

## Dimensional Data - Left Return Controls Detail

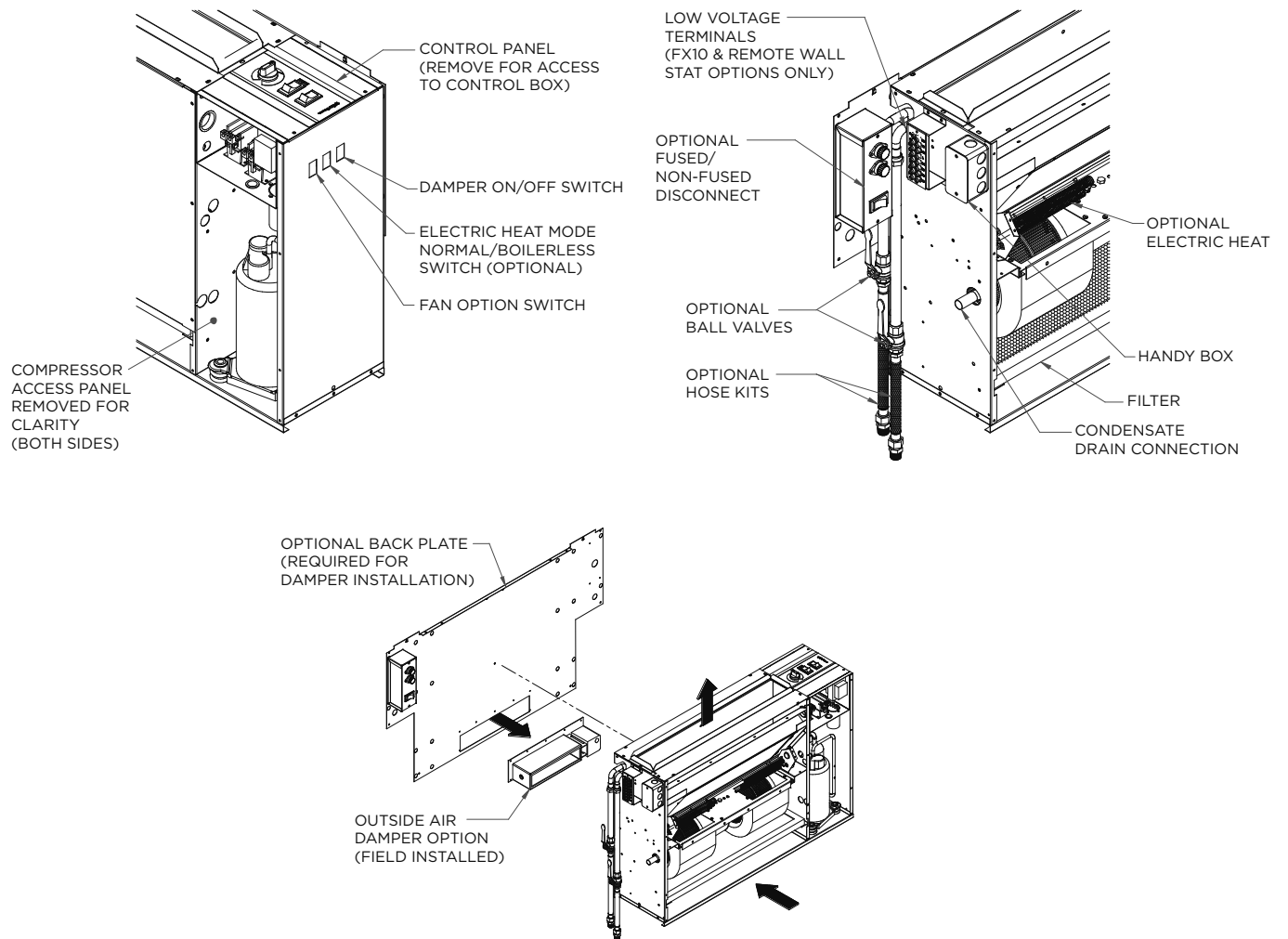

# Dimensional Data - Left Return Chassis

Data = inches (cm)

## Models 09-12

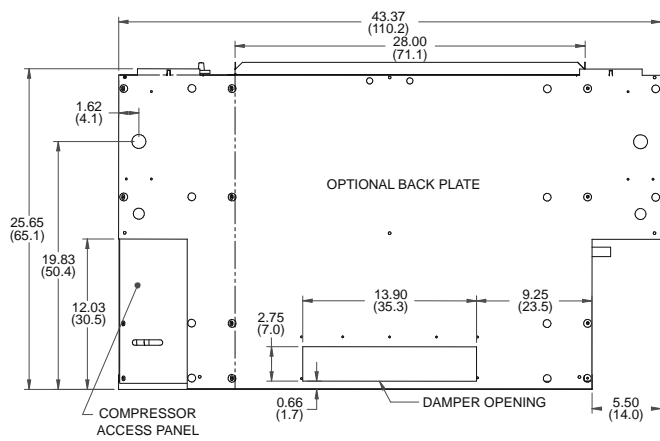
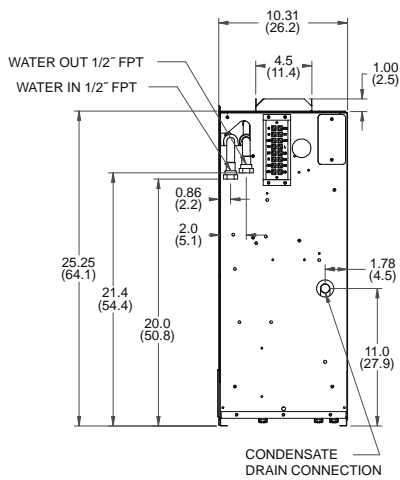
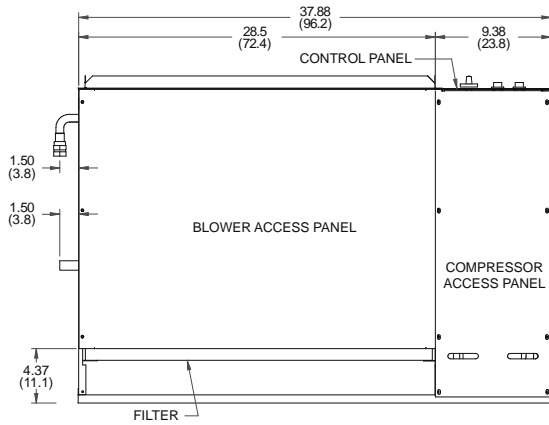

## Models 15-18

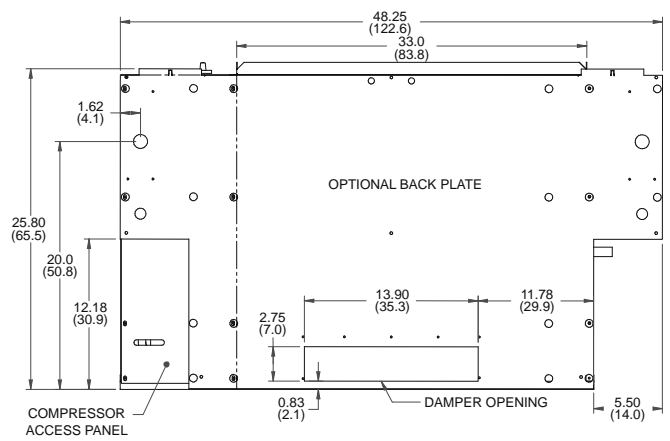
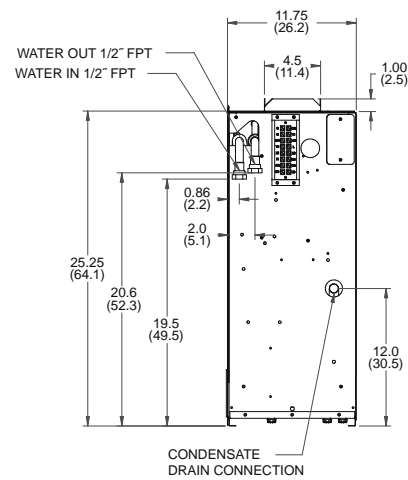
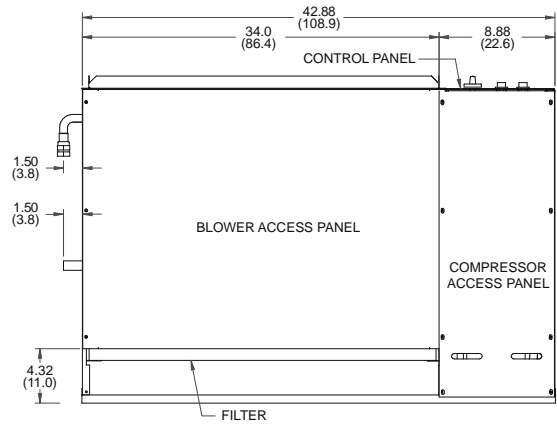

## Physical Data

Model		Consoles			
		09	12	15	18
Compressor (1 each)		Rotary			
Factory Charge R410A, oz [kg]		27 [0.77]	27 [0.77]	36 [1.02]	34 [0.96]
Fan Motor & Blower		3 Speeds			
Fan Motor Type/Speeds	ECM	3 Speeds			
Fan Motor- hp [W]	ECM	0.25 [186]	0.25 [186]	0.25 [186]	0.25 [186]
Blower Wheel Size (Dia x W), in. [mm]	ECM	5.75 x 5.5 [146 x 140]	5.75 x 5.5 [146 x 140]	6.0 x 6.5 [152 x 165]	6.0 x 6.5 [152 x 165]
Coax and Water Piping					
Water Connections Size - FPT - in [mm]		1/2" [12.7]	1/2" [12.7]	1/2" [12.7]	1/2" [12.7]
Coax & Piping Water Volume - gal [l]		0.15 [0.6]	0.18 [0.7]	0.35 [1.3]	0.35 [1.3]
Consoles					
Air Coil Dimensions (H x W), in. [mm]		8 x 22 [203 x 559]	8 x 22 [203 x 559]	8 x 30 [203 x 762]	8 x 30 [203 x 762]
Air Coil Total Face Area, ft <sup>2</sup> [m <sup>2</sup> ]		1.2 [0.114]	1.2 [0.114]	1.7 [0.155]	1.7 [0.155]
Air Coil Tube Size, in [mm]		3/8 [9.5]	3/8 [9.5]	3/8 [9.5]	3/8 [9.5]
Air Coil Number of rows		3	3	4	4
Filter Standard - 1" [25.4mm]		1 - 10 x 28 [254 x 711]	1 - 10 x 28 [254 x 711]	1 - 12 x 33 [305 x 838]	1 - 12 x 33 [305 x 838]
Weight - Operating, lb [kg]		210 [91]	210 [95]	230 [102]	235 [107]
Weight - Packaged, lb [kg]		220 [100]	220 [100]	240 [109]	245 [111]

1/20/14

## Electrical Data

### ECM Motor

Model	Rated Voltage	Voltage Min/Max	Compressor			Fan Motor FLA	Total Unit FLA	Min Circ Amp	Max Fuse/HACR
			MCC	RLA	LRA				
09	115/60/1	104/127	12.5	8.0	50.0	4.25	12.3	14.3	20
	208-230/60/1	187/253	6.4	4.1	21.0	2.6	6.7	7.7	10/15
	265/60/1	238/292	6.7	4.3	22.0	2.5	6.8	7.9	10/15
12	115/60/1	104/127	14.8	9.5	50.0	4.25	13.8	16.1	25
	208-230/60/1	187/253	7.7	4.9	25.0	2.6	7.5	8.8	10/15
	265/60/1	238/292	7.0	4.5	22.0	2.5	7.0	8.1	10/15
15	208-230/60/1	187/253	9.2	5.9	29.0	2.6	8.5	10.0	15
	265/60/1	238/292	7.8	5.0	28.0	2.5	7.5	8.8	10/15
18	208-230/60/1	187/253	10.4	6.7	33.5	2.6	9.3	10.9	15
	265/60/1	238/292	8.7	5.6	28.0	2.5	8.1	9.5	15

HACR circuit breaker in USA only

1/20/14



## Auxiliary Heat Ratings

### ECM Motors

Model	Rated Voltage	Voltage Min./Max.	Heater Element Watts	Fan Motor FLA	Heater Element FLA	Total Unit FLA	Min. Circuit Amp.	Max. Fuse/Brkr.
09-12 (1 kW)	208/60/1	197/254	818	2.45	3.93	6.4	8.0	10
	230/60/1	197/254	1000	2.60	4.35	7.0	8.7	15
	265/60/1	239/291	1000	2.50	3.77	6.3	7.8	10
09-12 (2 kW)	208/60/1	197/254	1636	2.45	7.86	10.3	12.9	20
	230/60/1	197/254	2000	2.60	8.70	11.3	14.1	25
	265/60/1	239/292	2000	2.50	7.55	10.1	12.6	20
15-18 (3 kW)	208/60/1	197/254	2454	2.45	11.80	14.3	17.8	30
	230/60/1	197/254	3000	2.60	13.04	15.6	19.6	35
	265/60/1	239/292	3000	2.50	11.32	13.8	17.3	30

Always refer to unit nameplate data prior to installation.

10/5/10

## Blower Performance Data

### ECM Motors

Model	CFM		
	Low Speed	Medium Speed	High Speed
09	300	325	400
12	300	325	400
15	350	450	600
18	350	450	600

For wet coil performance first calculate the face velocity of the air coil (Face Velocity [fpm] = Airflow [cfm] / Face Area [sq ft]). Then for velocities of 200 fpm reduce the static capability by 0.03 in. wg, 300 fpm by 0.08 in. wg, 400 fpm by 0.12in. wg. and 500 fpm by 0.16 in. wg.

## Pressure Drop

Model	GPM	Pressure Drop (psi)				
		30°F	50°F	70°F	90°F	110°F
09	1.2	1.0	0.9	0.8	0.7	0.6
	1.8	2.3	2.2	2.0	1.9	1.8
	2.5	3.8	3.7	3.5	3.3	3.1
12	1.5	0.9	0.8	0.7	0.6	0.5
	2.3	1.7	1.5	1.4	1.3	1.1
	3.5	3.0	2.7	2.5	2.4	2.2
15	2.0	1.7	1.6	1.5	1.4	1.3
	3.0	3.3	3.2	3.0	2.9	2.8
	4.5	5.7	5.5	5.3	5.1	4.9
18	3.0	1.7	1.6	1.5	1.4	1.3
	4.0	4.1	4.0	3.9	3.7	3.6
	5.5	7.9	7.6	7.4	7.2	6.9

12/14/09

## Correction Factor Tables

### Cooling Capacity Corrections

Entering Air WB °F	Total Clg Cap	Sensible Cooling Capacity Multipliers - Entering DB °F										Power Input	Heat of Rejection
		60	65	70	75	80	80.6	85	90	95	100		
45	0.719	0.891	1.058	1.128	*	*	*	*	*	*	*	0.898	0.741
50	0.719	0.893	0.980	1.106	*	*	*	*	*	*	*	0.898	0.741
55	0.812	0.629	0.844	1.026	1.172	*	*	*	*	*	*	0.922	0.819
60	0.897			0.820	0.995	1.206	1.238	*	*	*	*	0.955	0.895
65	0.960			0.568	0.810	1.004	1.052	1.227	*	*	*	0.982	0.951
66.2	0.984			0.505	0.743	1.002	1.027	1.151	*	*	*	0.993	0.980
67	1.000			0.463	0.699	1.000	1.011	1.101	1.310	*	*	1.000	1.000
70	1.047				0.599	0.865	0.879	1.007	1.225	1.433	*	1.018	1.029
75	1.148					0.567	0.584	0.734	0.956	1.261	1.476	1.056	1.118

Note: \* Sensible capacity equals total capacity at conditions shown.

7/20/06

### Heating Capacity Corrections

Ent Air DB °F	Heating Corrections		
	Htg Cap	Power	Heat of Ext
45	1.050	0.749	1.158
50	1.059	0.859	1.130
55	1.043	0.894	1.096
60	1.033	0.947	1.064
65	1.023	0.974	1.030
68	1.009	0.990	1.012
70	1.000	1.000	1.000
75	1.011	1.123	0.970
80	1.000	1.196	0.930

7/20/06

## Reference Calculations

Heating Calculations:	Cooling Calculations:
$LWT = EWT - \frac{HE}{GPM \times 500}$	$LWT = EWT + \frac{HR}{GPM \times 500}$
$LAT = EAT + \frac{HC}{CFM \times 1.08}$	$LAT (DB) = EAT (DB) - \frac{SC}{CFM \times 1.08}$
$TH = HC + HW$	$LC = TC - SC$
	$S/T = \frac{SC}{TC}$

## Legend and Notes

### ABBREVIATIONS AND DEFINITIONS:

CFM = airflow, cubic feet/minute  
 EWT = entering water temperature, Fahrenheit  
 GPM = water flow in gallons/minute  
 WPD = water pressure drop, PSI and feet of water  
 EAT = entering air temperature, Fahrenheit (dry bulb/wet bulb)  
 HC = air heating capacity, MBTUH  
 TC = total cooling capacity, MBTUH  
 SC = sensible cooling capacity, MBTUH  
 KW = total power unit input, kilowatts  
 HR = total heat of rejection, MBTUH

HE = total heat of extraction, MBTUH  
 HW = desuperheater capacity, MBTUH  
 EER = Energy Efficient Ratio = BTU output/Watt input  
 COP = Coefficient of Performance = BTU output/BTU input  
 LWT = leaving water temperature, °F  
 LAT = leaving air temperature, °F  
 TH = total heating capacity, MBTUH  
 LC = latent cooling capacity, MBTUH  
 S/T = sensible to total cooling ratio

### Notes to Performance Data Tables

- Performance ratings are based on 80°F DB / 67°F WB EAT for cooling and 70°F DB EAT for heating.
- Three flow rates are shown for each unit. The lowest flow rate shown is used for geothermal open loop/well water systems with a minimum of 50°F EWT. The middle flow rate shown is the minimum geothermal closed loop flow rate. The highest flow rate shown is optimum for geothermal closed loop systems and the suggested flow rate for boiler/ tower applications.
- The desuperheater numbers are based on a flow rate of 0.4 GPM/ton of rated capacity with an EWT of 90°F.
- Entering water temperatures below 40°F assumes 15% antifreeze solution.
- For non-standard EAT conditions, apply the appropriate correction factors on (Refer to Correction Factor Tables).
- Interpolation between EWT, GPM and CFM data is permissible.

## Operating Limits

Operating Limits	Cooling		Heating	
	(°F)	(°C)	(°F)	(°C)
<b>Air Limits</b>				
Min. Ambient Air	45	7.2	45	7.2
Rated Ambient Air	80	26.7	70	21.1
Max. Ambient Air	100	37.8	85	29.4
Min. Entering Air	50	10.0	40	4.4
Rated Entering Air db/wb	80.6/66.2	27/19	68	20.0
Max. Entering Air db/wb	110/83	43/28.3	80	26.7
<b>Water Limits</b>				
Min. Entering Water	30	-1.1	20	-6.7
Normal Entering Water	50-110	10-43.3	30-70	-1.1
Max. Entering Water	120	48.9	90	32.2

**NOTE:** Minimum/maximum limits are only for start-up conditions, and are meant for bringing the space up to occupancy temperature. Units are not designed to operate at the minimum/maximum conditions on a regular basis. The operating limits are dependent upon three primary factors: 1) water temperature, 2) return air temperature, and 3) ambient temperature. When any of the factors are at the minimum or maximum levels, the other two factors must be at the normal level for proper and reliable unit operation.

# YC09 - Performance Data

300 Rated CFM Heating / Cooling

Performance capacities shown in thousands of Btuh.

EWT °F	Flow Rate GPM	Water Pressure Drop		HEATING - EAT 70 °F					COOLING - EAT 80/67 °F					
		PSI	FT/HD	HC kBtuh	Power kW	HE kBtuh	LAT °F	COP	TC kBtuh	SC kBtuh	S/T Ratio	Power kW	HR kBtuh	EER
20	1.2	1.1	2.5	Operation not recommended					Operation not recommended					
	1.8	2.4	5.6	Operation not recommended					Operation not recommended					
	2.5	3.8	8.8	6.8	0.60	4.8	89.0	3.35	Operation not recommended					
30	1.2	1.0	2.3	Operation not recommended					Operation not recommended					
	1.8	2.3	5.4	6.9	0.60	4.8	89.3	3.38	12.1	7.3	0.61	0.38	13.4	31.8
	2.5	3.8	8.8	7.3	0.63	5.1	90.5	3.40	12.2	7.4	0.61	0.36	13.4	33.9
40	1.2	1.0	2.2	7.6	0.62	5.5	91.5	3.63	Operation not recommended					
	1.8	2.3	5.2	7.9	0.62	5.8	92.4	3.72	11.5	7.1	0.62	0.41	12.9	28.1
	2.5	3.8	8.7	8.3	0.64	6.1	93.7	3.80	11.6	7.2	0.62	0.39	12.9	30.0
50	1.2	0.9	2.1	8.8	0.65	6.6	95.2	4.00	10.7	6.8	0.63	0.45	12.3	23.6
	1.8	2.2	5.1	9.1	0.65	6.9	96.0	4.08	10.9	6.9	0.63	0.44	12.3	24.9
	2.5	3.7	8.5	9.4	0.66	7.1	97.0	4.17	11.0	7.0	0.64	0.41	12.4	26.6
60	1.2	0.9	2.0	10.3	0.68	8.0	99.8	4.46	10.4	6.7	0.64	0.52	12.1	19.9
	1.8	2.1	4.9	10.5	0.68	8.2	100.5	4.53	10.5	6.7	0.64	0.50	12.2	21.0
	2.5	3.6	8.3	10.8	0.69	8.5	101.3	4.60	10.7	6.9	0.64	0.47	12.3	22.4
70	1.2	0.8	1.8	11.8	0.71	9.4	104.5	4.88	10.0	6.5	0.65	0.59	12.0	17.1
	1.8	2.0	4.7	12.0	0.71	9.6	105.0	4.93	10.1	6.6	0.65	0.56	12.1	18.0
	2.5	3.5	8.1	12.2	0.72	9.8	105.7	4.99	10.3	6.7	0.65	0.54	12.1	19.2
80	1.2	0.8	1.7	12.7	0.73	10.2	107.3	5.11	9.5	6.3	0.67	0.65	11.7	14.5
	1.8	2.0	4.6	12.9	0.74	10.4	107.9	5.12	9.6	6.5	0.67	0.62	11.7	15.5
	2.5	3.4	7.9	13.1	0.75	10.5	108.4	5.13	9.9	6.5	0.66	0.60	11.9	16.4
90	1.2	0.7	1.6	13.6	0.76	11.0	110.0	5.24	9.2	6.1	0.67	0.72	11.6	12.7
	1.8	1.9	4.4	13.8	0.77	11.2	110.6	5.25	9.3	6.2	0.67	0.69	11.7	13.5
	2.5	3.3	7.6	14.0	0.78	11.3	111.2	5.26	9.4	6.3	0.67	0.67	11.7	14.1
100	1.2	0.7	1.5	Operation not recommended					Operation not recommended					
	1.8	1.8	4.3						Operation not recommended					
	2.5	3.2	7.4						9.0	6.0	0.67	0.76	11.6	11.8
110	1.2	0.6	1.5						Operation not recommended					
	1.8	1.8	4.1						Operation not recommended					
	2.5	3.1	7.2						8.6	5.8	0.67	0.83	11.5	10.4
120	1.2	0.6	1.4						Operation not recommended					
	1.8	1.7	4.0						Operation not recommended					
	2.5	3.0	6.9						8.2	5.5	0.67	0.90	11.3	9.1

# YC12 - Performance Data

350 Rated CFM Heating / Cooling

Performance capacities shown in thousands of Btuh.

EWT °F	Flow Rate GPM	Water Pressure Drop		HEATING - EAT 70 °F					COOLING - EAT 80/67 °F											
		PSI	FT/HD	HC kBtuh	Power kW	HE kBtuh	LAT °F	COP	TC kBtuh	SC kBtuh	S/T Ratio	Power kW	HR kBtuh	EER						
															Operation not recommended					
20	1.5	1.0	2.3	Operation not recommended					Operation not recommended											
	2.3	1.7	4.0	Operation not recommended					Operation not recommended											
	3.5	3.2	7.4	8.6	0.80	5.9	90.8	3.15	Operation not recommended											
30	1.5	0.9	2.1	Operation not recommended					Operation not recommended											
	2.3	1.7	3.8	10.0	0.85	7.1	94.3	3.44	14.2	9.8	0.69	0.45	15.8	31.6						
	3.5	3.0	6.9	10.2	0.86	7.3	95.1	3.48	14.4	10.0	0.69	0.42	15.9	34.1						
40	1.5	0.9	2.0	10.8	0.88	7.8	96.7	3.62	Operation not recommended											
	2.3	1.6	3.7	11.0	0.88	8.0	97.0	3.66	13.7	9.5	0.70	0.54	15.5	25.5						
	3.5	2.9	6.6	11.3	0.89	8.2	97.8	3.72	13.9	9.7	0.70	0.50	15.6	27.6						
50	1.5	0.8	1.8	11.9	0.91	8.8	99.6	3.86	13.0	9.1	0.70	0.64	15.2	20.2						
	2.3	1.5	3.5	12.1	0.91	9.0	100.0	3.89	13.1	9.2	0.71	0.62	15.2	21.1						
	3.5	2.7	6.2	12.3	0.92	9.2	100.6	3.94	13.3	9.4	0.71	0.58	15.3	22.8						
60	1.5	0.8	1.7	13.2	0.94	10.0	103.0	4.14	12.1	8.6	0.71	0.71	14.5	17.0						
	2.3	1.4	3.3	13.4	0.94	10.2	103.4	4.16	12.2	8.7	0.71	0.68	14.5	17.8						
	3.5	2.6	6.0	13.7	0.96	10.4	104.2	4.19	12.4	8.9	0.71	0.65	14.6	19.2						
70	1.5	0.7	1.6	14.5	0.97	11.2	106.4	4.39	11.1	8.0	0.72	0.77	13.8	14.4						
	2.3	1.4	3.2	14.7	0.98	11.4	106.9	4.40	11.3	8.1	0.72	0.75	13.8	15.0						
	3.5	2.5	5.8	15.0	1.00	11.6	107.7	4.41	11.5	8.3	0.72	0.71	13.9	16.3						
80	1.5	0.7	1.5	15.6	1.03	12.1	109.4	4.45	10.6	7.8	0.73	0.84	13.5	12.6						
	2.3	1.3	3.0	15.9	1.04	12.3	110.0	4.48	10.9	7.9	0.73	0.80	13.6	13.5						
	3.5	2.5	5.7	16.1	1.05	12.5	110.6	4.50	11.0	8.0	0.73	0.78	13.7	14.1						
90	1.5	0.6	1.4	16.7	1.07	13.0	112.1	4.55	10.2	7.5	0.73	0.92	13.4	11.1						
	2.3	1.3	2.9	16.9	1.09	13.2	112.8	4.56	10.4	7.6	0.74	0.88	13.4	11.8						
	3.5	2.4	5.5	17.2	1.10	13.4	113.5	4.57	10.5	7.7	0.73	0.85	13.4	12.4						
100	1.5	0.6	1.3	Operation not recommended					Operation not recommended											
	2.3	1.2	2.8						9.7	7.3	0.75	1.00	13.1	9.7						
	3.5	2.3	5.3						9.8	7.4	0.75	0.97	13.1	10.1						
110	1.5	0.5	1.2						Operation not recommended						Operation not recommended					
	2.3	1.1	2.6						8.9	6.9	0.77	1.11	12.7	8.1						
	3.5	2.2	5.1						9.1	7.0	0.77	1.08	12.8	8.4						
120	1.5	0.5	1.2						Operation not recommended						Operation not recommended					
	2.3	1.1	2.5						8.5	6.7	0.79	1.21	12.6	7.0						
	3.5	2.1	4.9						8.7	6.8	0.78	1.18	12.7	7.4						

# YC15 - Performance Data

450 Rated CFM Heating / Cooling

Performance capacities shown in thousands of Btuh.

EWT °F	Flow Rate GPM	Water Pressure Drop		HEATING - EAT 70 °F					COOLING - EAT 80/67 °F					
		PSI	FT/HD	HC kBtuh	Power kW	HE kBtuh	LAT °F	COP	TC kBtuh	SC kBtuh	S/T Ratio	Power kW	HR kBtuh	EER
20	2.0	1.8	4.1	Operation not recommended					Operation not recommended					
	3.0	3.4	7.8	Operation not recommended					Operation not recommended					
	4.5	5.9	13.6	10.7	0.93	7.5	90.0	3.37	Operation not recommended					
30	2.0	1.7	3.9	Operation not recommended					Operation not recommended					
	3.0	3.3	7.6	11.8	0.95	8.5	92.2	3.62	17.1	12.2	0.71	0.48	18.7	35.6
	4.5	5.7	13.2	12.3	0.97	9.0	93.3	3.72	17.3	12.4	0.71	0.45	18.9	38.4
40	2.0	1.7	3.8	12.7	0.95	9.4	94.1	3.93	Operation not recommended					
	3.0	3.2	7.5	12.9	0.96	9.6	94.6	3.94	16.7	12.0	0.72	0.60	18.8	27.8
	4.5	5.6	12.9	13.4	0.98	10.1	95.6	4.02	17.0	12.2	0.72	0.57	18.9	30.0
50	2.0	1.6	3.7	13.9	0.95	10.6	96.5	4.27	16.2	11.7	0.72	0.75	18.8	21.5
	3.0	3.2	7.3	14.1	0.97	10.8	97.1	4.28	16.4	11.8	0.72	0.72	18.8	22.6
	4.5	5.5	12.7	14.6	0.99	11.2	97.9	4.31	16.6	12.0	0.72	0.68	18.9	24.4
60	2.0	1.6	3.6	15.2	0.96	12.0	99.4	4.66	15.5	11.4	0.74	0.84	18.3	18.3
	3.0	3.1	7.1	15.6	0.97	12.2	100.0	4.69	15.6	11.5	0.74	0.81	18.4	19.2
	4.5	5.4	12.5	16.1	1.00	12.7	101.0	4.72	15.9	11.8	0.74	0.77	18.5	20.7
70	2.0	1.5	3.5	16.6	0.96	13.3	102.2	5.05	14.7	11.1	0.76	0.94	17.9	15.7
	3.0	3.0	7.0	17.0	0.98	13.7	103.0	5.08	14.9	11.3	0.76	0.90	18.0	16.5
	4.5	5.3	12.2	17.6	1.00	14.1	104.1	5.12	15.2	11.5	0.76	0.86	18.1	17.8
80	2.0	1.5	3.4	18.3	1.03	14.8	105.7	5.22	14.2	10.9	0.77	1.00	17.6	14.1
	3.0	3.0	6.8	18.6	1.04	15.1	106.3	5.24	14.5	11.1	0.77	0.96	17.7	15.1
	4.5	5.2	12.0	18.9	1.05	15.3	106.8	5.26	14.7	11.2	0.76	0.93	17.8	15.8
90	2.0	1.4	3.2	19.6	1.07	15.9	108.3	5.35	13.7	10.6	0.77	1.08	17.4	12.7
	3.0	2.9	6.7	19.9	1.09	16.2	108.9	5.36	13.9	10.8	0.78	1.03	17.4	13.5
	4.5	5.1	11.8	20.2	1.10	16.4	109.5	5.38	14.1	10.9	0.77	1.00	17.5	14.1
100	2.0	1.4	3.1	Operation not recommended					Operation not recommended					
	3.0	2.8	6.5						13.4	10.5	0.78	1.14	17.3	11.8
	4.5	5.0	11.6						13.6	10.6	0.78	1.10	17.3	12.3
110	2.0	1.3	3.0						Operation not recommended					
	3.0	2.8	6.4						12.8	10.1	0.79	1.23	17.0	10.4
	4.5	4.9	11.3						13.0	10.3	0.79	1.20	17.1	10.8
120	2.0	1.3	2.9						Operation not recommended					
	3.0	2.7	6.2						11.3	9.2	0.81	1.39	16.0	8.1
	4.5	4.8	11.1						11.5	9.3	0.81	1.35	16.1	8.5

# YC18 - Performance Data

500 Rated CFM Heating / Cooling

Performance capacities shown in thousands of Btu/h.

EWT °F	Flow Rate GPM	Water		HEATING - EAT 70 °F					COOLING - EAT 80/67 °F					
		Pressure Drop		HC kBtu/h	Power kW	HE kBtu/h	LAT °F	COP	TC kBtu/h	SC kBtu/h	S/T Ratio	Power kW	HR kBtu/h	EER
		PSI	FT/HD											
20	3.0	1.8	4.1	Operation not recommended					Operation not recommended					
	4.0	4.2	9.7	Operation not recommended					Operation not recommended					
	5.5	8.0	18.5	13.0	1.20	8.9	92.0	3.16	Operation not recommended					
30	3.0	1.7	3.9	Operation not recommended					Operation not recommended					
	4.0	4.1	9.6	14.2	1.24	10.0	94.3	3.35	22.2	16.0	0.72	0.69	24.6	32.1
	5.5	7.9	18.2	14.3	1.25	10.1	94.5	3.36	22.5	16.3	0.72	0.65	24.7	34.6
40	3.0	1.7	3.8	15.5	1.26	11.2	96.7	3.60	Operation not recommended					
	4.0	4.1	9.4	15.8	1.27	11.5	97.3	3.65	21.3	15.5	0.72	0.79	24.1	26.9
	5.5	7.8	17.9	16.2	1.28	11.8	98.0	3.71	21.7	15.8	0.73	0.75	24.2	29.1
50	3.0	1.6	3.7	17.2	1.28	12.8	99.9	3.93	20.3	14.8	0.73	0.93	23.5	21.9
	4.0	4.0	9.2	17.6	1.29	13.2	100.5	3.98	20.5	14.9	0.73	0.89	23.5	23.0
	5.5	7.6	17.6	18.1	1.31	13.6	101.5	4.05	20.8	15.2	0.73	0.84	23.7	24.8
60	3.0	1.6	3.6	19.2	1.30	14.8	103.6	4.33	19.0	13.9	0.73	1.01	22.4	18.7
	4.0	3.9	9.1	19.7	1.32	15.2	104.4	4.37	19.2	14.1	0.73	0.97	22.5	19.7
	5.5	7.5	17.3	20.3	1.34	15.7	105.6	4.43	19.5	14.4	0.74	0.92	22.6	21.2
70	3.0	1.5	3.5	21.3	1.32	16.8	107.4	4.71	17.6	13.1	0.74	1.09	21.3	16.1
	4.0	3.9	8.9	21.8	1.34	17.2	108.3	4.75	17.8	13.2	0.74	1.06	21.5	16.9
	5.5	7.4	17.1	22.5	1.37	17.8	109.7	4.80	18.2	13.5	0.74	1.00	21.6	18.2
80	3.0	1.5	3.4	23.3	1.40	18.6	111.2	4.88	17.1	12.9	0.75	1.25	21.3	13.7
	4.0	3.8	8.8	23.7	1.41	18.9	111.9	4.92	17.4	13.1	0.75	1.19	21.5	14.7
	5.5	7.3	16.9	24.0	1.43	19.1	112.4	4.93	17.7	13.2	0.75	1.15	21.6	15.3
90	3.0	1.4	3.2	24.7	1.44	19.8	113.8	5.03	16.6	12.6	0.76	1.41	21.4	11.8
	4.0	3.7	8.6	25.1	1.46	20.1	114.5	5.04	16.9	12.8	0.76	1.34	21.5	12.6
	5.5	7.2	16.6	25.5	1.48	20.5	115.2	5.06	17.1	12.9	0.75	1.30	21.5	13.2
100	3.0	1.4	3.1	Operation not recommended					Operation not recommended					
	4.0	3.7	8.5						16.4	12.5	0.76	1.49	21.5	11.0
	5.5	7.1	16.3						16.6	12.6	0.76	1.44	21.5	11.5
110	3.0	1.3	3.0						Operation not recommended					
	4.0	3.6	8.3						15.8	12.1	0.77	1.62	21.3	9.7
	5.5	6.9	15.9						16.0	12.3	0.77	1.58	21.4	10.1
120	3.0	1.3	2.9						Operation not recommended					
	4.0	3.5	8.2						14.7	11.7	0.80	1.77	20.8	8.3
	5.5	6.8	15.7						15.0	11.9	0.79	1.72	20.9	8.7

# Wiring Schematics

CCM - with ECM Motor and Electronic Stat

208-230-265/60/1

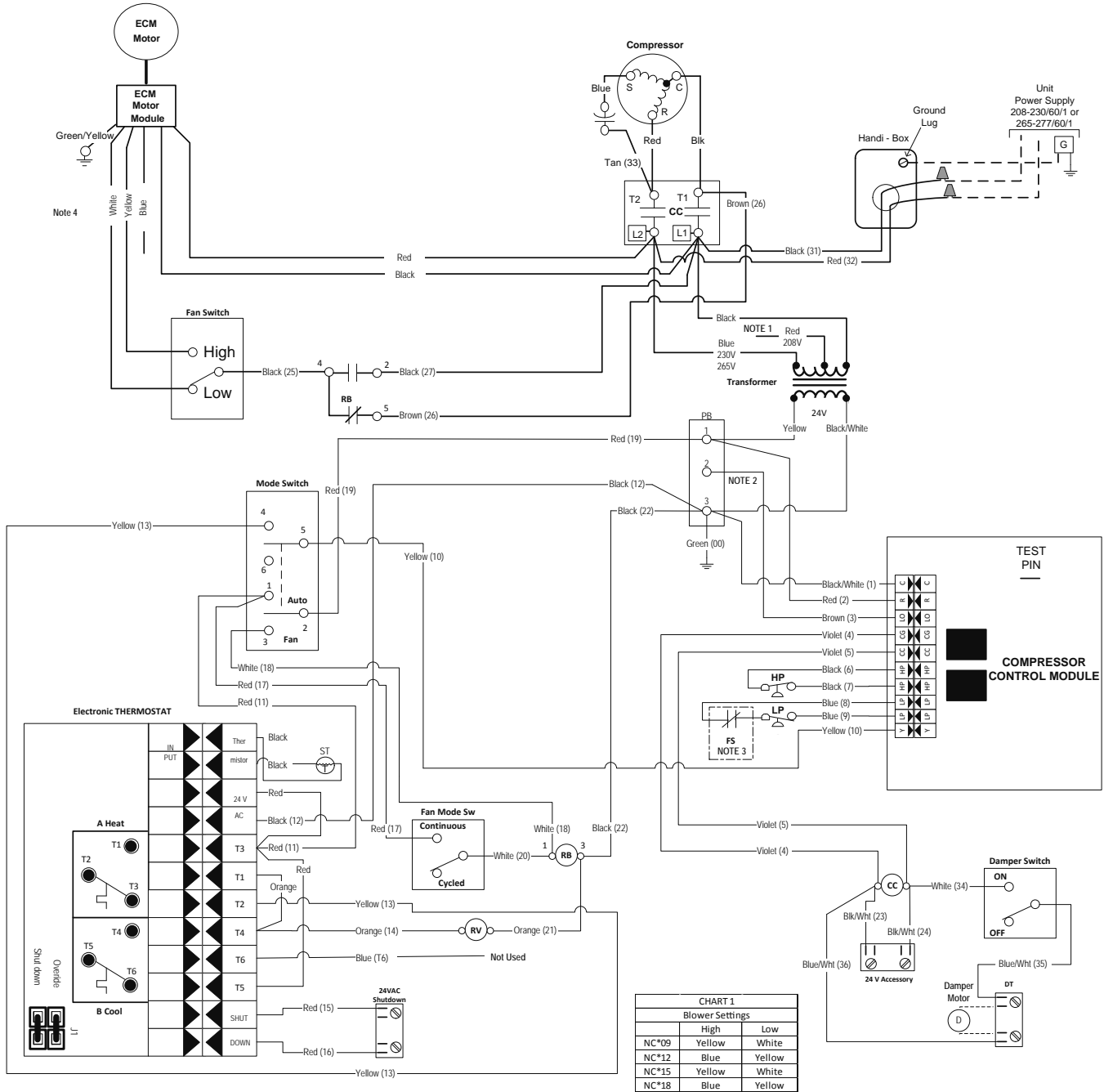

## Legend

<p>— Factory low voltage wiring</p> <p>— Factory line voltage wiring</p> <p>- - - Field low voltage wiring</p> <p>- - - Field line voltage wiring</p> <p>○ Quick connect terminal</p> <p>▲ Wire nut</p>	<p>CC - Compressor Contactor</p> <p>DT - Damper Terminal Block</p> <p>FS - Freeze Sensing Device</p> <p>HP - High Pressure Switch</p> <p>LP - Low Pressure Switch</p> <p>PB - Power Block</p> <p>RB - Blower Relay</p> <p>RV - Reversing Valve Coil</p> <p>ST - Entering Air Temperature Sensor</p>	<p>L1 Field wire lug</p> <p>Earth Ground</p> <p>Relay Contacts - N.O., N.C.</p> <p>Polarized connector</p>	<p>HP Switch - High Pressure</p> <p>LP Switch - Low Pressure</p> <p>Relay coil</p> <p>Capacitor</p> <p>Thermistor</p> <p>Temperature Switch</p>	<p><b>Notes:</b></p> <ol style="list-style-type: none"> <li>1. Switch Red and Blue wires for 208 volt operation</li> <li>2. Terminal C of 24 V PB is used as "L" output for Brown wire 3 for Lockout.</li> <li>3. Optional field installed freeze sensing device.</li> <li>4. Factory wired. Refer to blower table settings.</li> </ol>
---	---	--	---	---



# Wiring Schematics cont.

## CCM - with ECM, Electric Heat and Electronic Stat

208-230-265/60/1

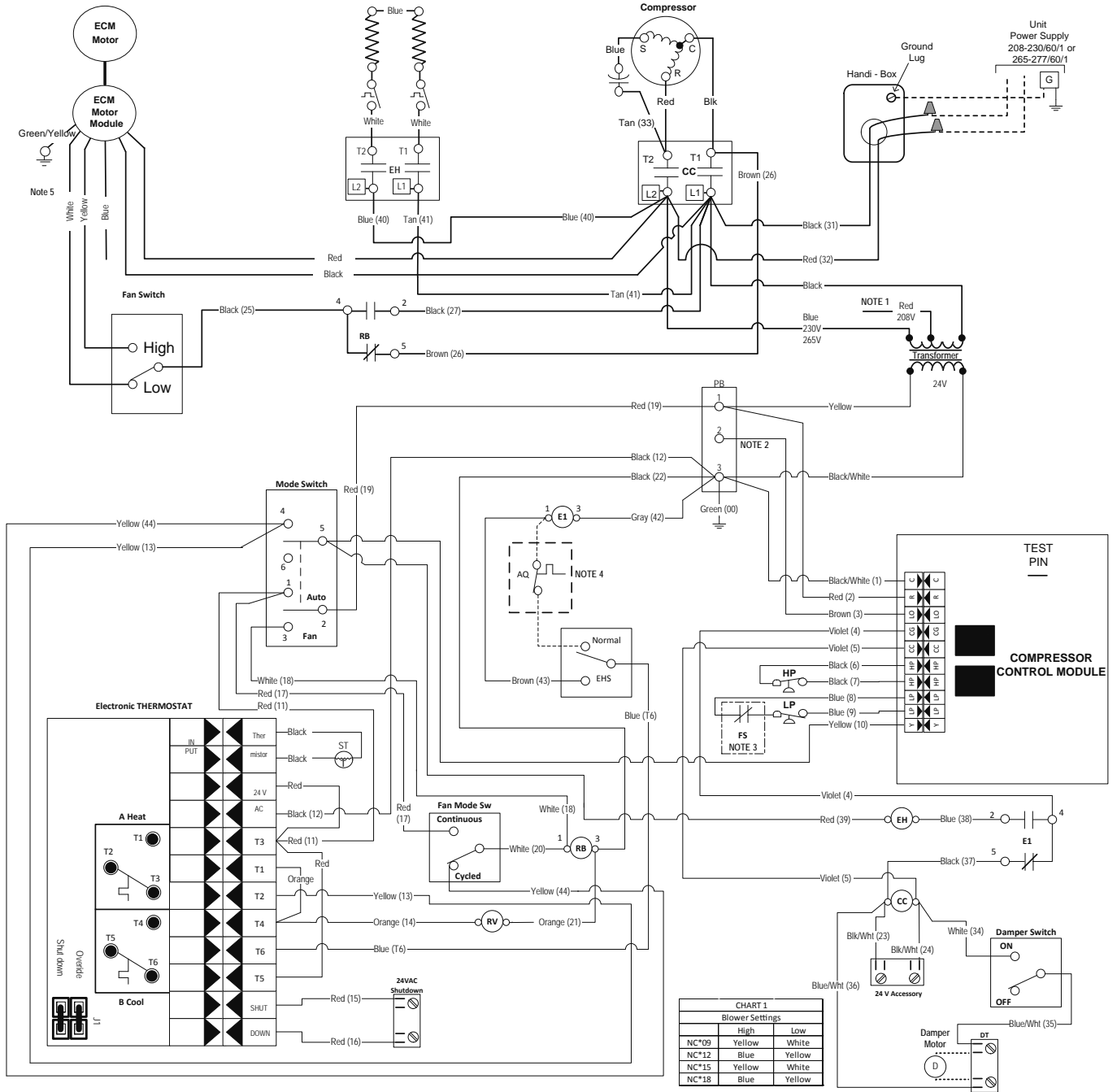

### Legend

Factory low voltage wiring	L1 - Field wire lug	HP - Switch - High Pressure	<b>Notes:</b> 1. Switch Red and Blue wires for 208 volt operation 2. Terminal C of 24 V PB is used as "L" output for Brown wire 3 for Lockout. 3. Optional field installed freeze sensing device. 4. Optional field installed aquastat. 5. Factory wired. Refer to blower table settings.
Factory line voltage wiring	Earth Ground	LP - Switch - Low Pressure	
Field low voltage wiring	Relay Contacts - N.O., N.C.	Relay coil	
Field line voltage wiring	Polarized connector	Capacitor	
Quick connect terminal		Thermistor	
Wire nut		Temperature Switch	

# Wiring Schematics cont.

## ABC - ECM with Electric Heat and Remote Stat

208-230-265/60/1

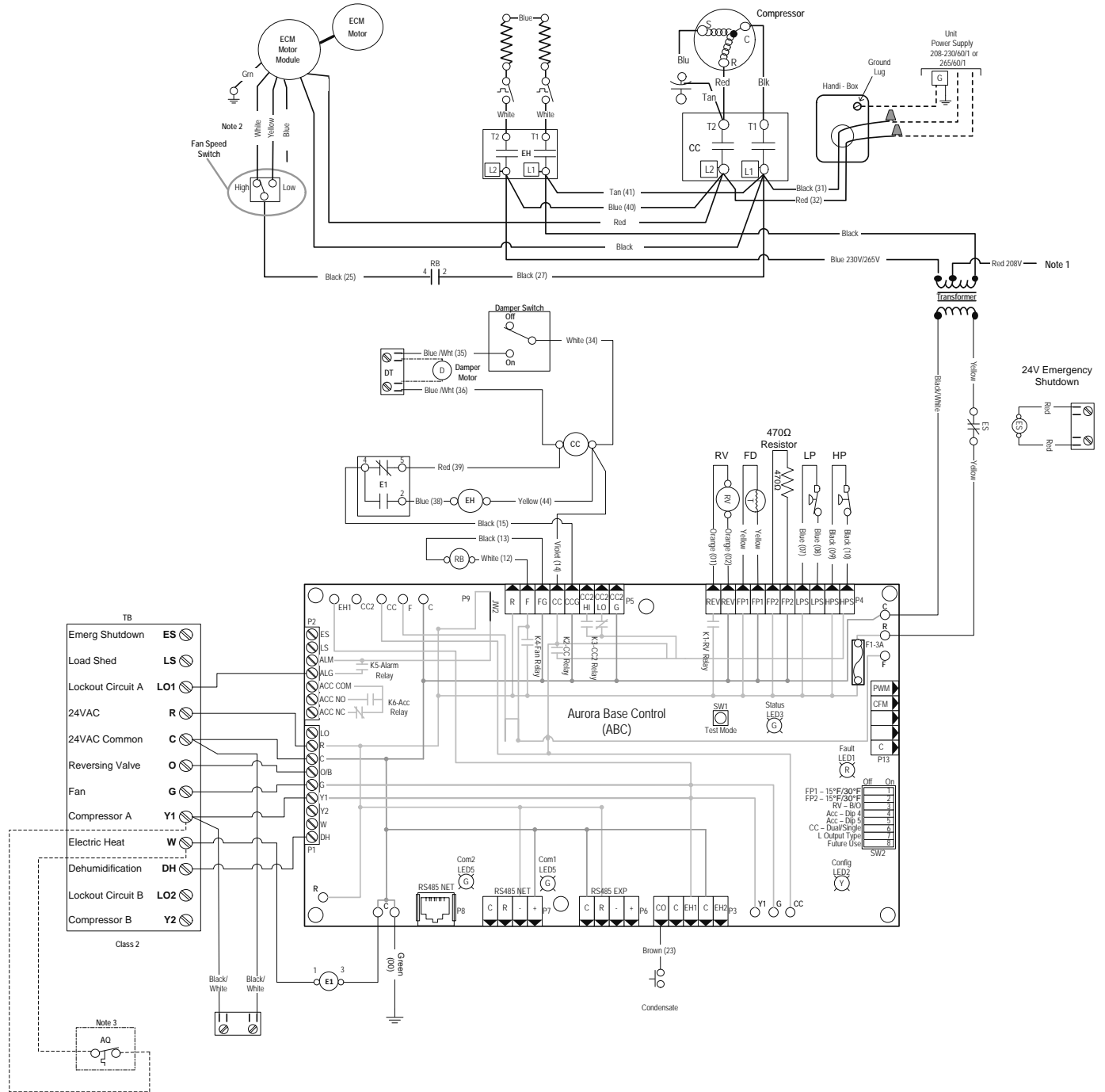

# Wiring Schematics cont.

ABC - ECM with Electric Heat and Remote Stat

208230265/60/1

**Notes:**

- 1 - Swap blue and red leads for 208V operation.
- 2 - Factory wired. Refer to blower table settings.
- 3 Optional field installed Aquastat for use with single heat.

Accessory Relay		
Operation	SW2-4	SW2-5
Cycle with Blower	On	On
Cycle with Compressor	Off	Off
Water Valve Slow Open	On	Off
Outdoor Air Damper	Off	On

Aurora Timing Events		
Event	Normal Mode	Test Mode
Random Start Delay	5 to 80 seconds	1 second
Compressor On Delay	5 seconds	< 1 second
Compressor Minimum On Time	2 minutes	5 seconds
Compressor Short Cycle Delay	4 minutes	15 seconds
Blower Off Delay	30 seconds	2 seconds
Fault Recognition Delay - High Pressure	Less than 1 second	Less than 1 second
Start-Up Bypass - Low Pressure	2 minutes	30 seconds
Fault Recognition Delay - Low Pressure	30 seconds	30 seconds
Start-Up Bypass - Low Water/Air Coil Limit	2 minutes	30 seconds
Fault Recognition Delay - Low Water/Air Coil Limit	30 seconds	30 seconds
Fault Recognition Delay - Condensate Overflow	30 seconds	30 seconds
Thermostat Call Recognition Time	2 seconds	2 seconds
Auxiliary Heat Staging Delay	5 minutes	20 seconds
Emergency Heat Staging Delay	2 minutes	7.5 seconds
Water Valve Slow Open Delay	90 seconds	90 seconds
Reheat Delay	30 seconds	30 seconds

Aurora LED Flash Codes			
Slow Flash	1 second on and 1 second off		
Fast Flash	100 milliseconds on and 100 milliseconds off		
Flash Code	100 milliseconds on and 400 milliseconds off with a 2 second pause before repeating		
Random Start Delay			
Status LED (LED1, Green)	Fast Flash		
Configuration LED (LED2, Yellow)	Fast Flash		
Fault LED (LED3, Red)	Fast Flash		
Status LED (LED1, Green)	Configuration LED (LED2, Yellow)	Fault LED (LED3, Red)	
Normal Mode	ON	No Software Override	Flash ECM Setting
Control is Non-Functional	OFF	DIP Switch Override	Slow Flash
Test Mode	Slow Flash	ECM Configure Mode	Fast Flash
Lockout Active	Fast Flash	Reset Configure Mode	Off
Dehumidification Mode	Flash Code 2		Low Pressure Lockout
Reserved	Flash Code 3		Low Air Coil Limit Lockout - FP2
Reserved	Flash Code 4		Low Water Coil Limit Lockout - FP1
Load Shed	Flash Code 5		Reserved
ESD	Flash Code 6		Condensate Overflow Lockout
Reserved	Flash Code 7		Over/Under Voltage Shutdown
			Reserved
			Reserved
			Reserved
			Air/Water Coil Limit Sensor Error

CHART 1 Blower Settings		
	High	Low
NC*09	Yellow	White
NC*12	Blue	Yellow
NC*15	Yellow	White
NC*18	Blue	Yellow

### Legend

	Factory Low Voltage Wiring		Thermistor
	Factory Line Voltage Wiring		Relay Coil
	Field Low Voltage Wiring		Switch - Condensate Overflow
	Field Line Voltage Wiring		Switch - High pressure
	Optional Block		Switch - Low pressure
	DC Voltage PCB Traces		Polarized connector
	Field Zone Sensor Wiring		Light Emitting Diode - Green
	Internal Junction		Light Emitting Diode - Yellow
	Quick Connect Terminal		Light Emitting Diode - Red
	Field Wiring Lug		Wire nut
	Ground		
	Relay Contacts - N.O., N.C.		
	Capacitor		
	Fuse		
	Temperature Switch		

AO - Aquastat	SW1 - Push button
CG - Compressor Contactor	SW2 - DIP package 8 position
CO - Condensate Overflow Sensor	PB - Power Block
ES - Emergency Shutdown	RB - Blower Relay
HP - High Pressure Switch	RV - Reversing Valve Coil
LP - Low Pressure Switch	
FD - Freeze Detection Sensor	
F1 - Fuse	

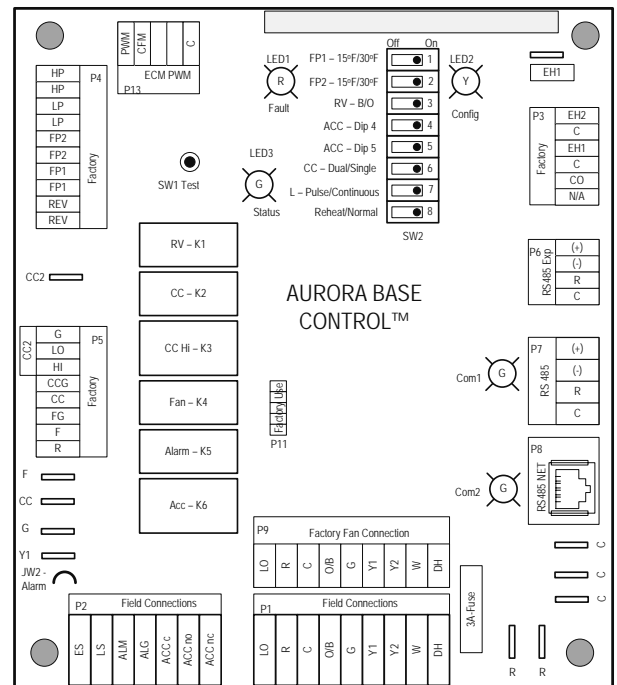

# Wiring Schematics cont.

ABC - with ECM and Electronic Stat

208-230-265/60/1

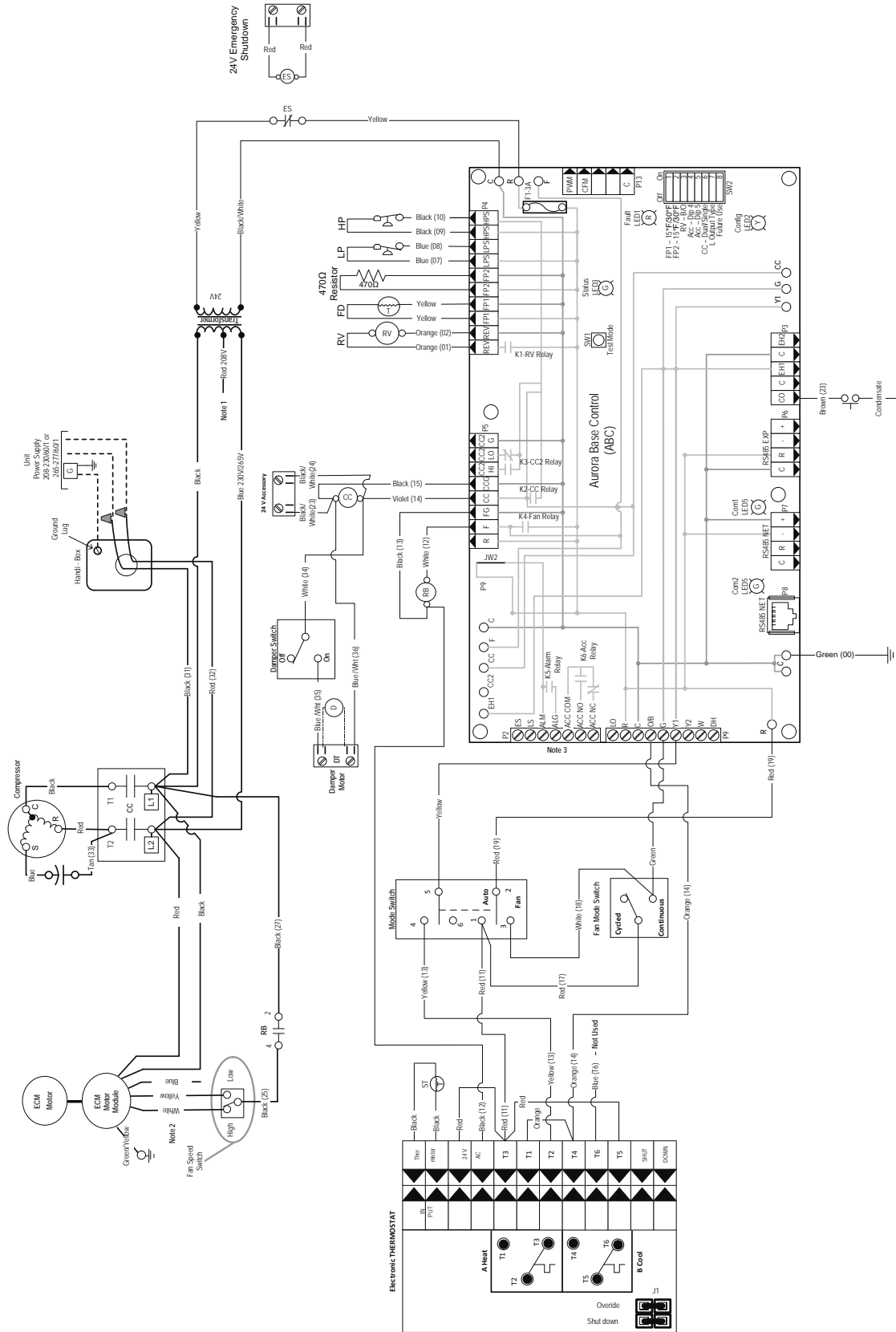

# Wiring Schematics cont.

ABC - with ECM and Electronic Stat

208-230-265/60/1

Accessory Relay		
Operation	SW2-4	SW2-5
Cycle with blower	On	On
Cycle with compressor	Off	Off
Water Valve Slow Open	On	Off
Outdoor Air Damper	Off	On

Aurora Timing Events		
Event	Normal Mode	Test Mode
Random Start Delay	5 to 80 seconds	1 second
Compressor On Delay	5 seconds	< 1 second
Compressor Minimum On Time	2 minutes	5 seconds
Compressor Short Cycle Delay	4 minutes	15 seconds
Blower Off Delay	30 seconds	2 seconds
Fault Recognition Delay - High Pressure	Less than 1 second	Less than 1 second
Start-Up Bypass - Low Pressure	2 minutes	30 seconds
Fault Recognition Delay - Low Pressure	30 seconds	30 seconds
Start-Up Bypass - Low Water/Air Coil Limit	2 minutes	30 seconds
Fault Recognition Delay - Low Water/Air Coil Limit	30 seconds	30 seconds
Fault Recognition Delay - Condensate Overflow	30 seconds	30 seconds
Thermostat Call Recognition Time	2 seconds	2 seconds
Auxiliary Heat Staging Delay	5 minutes	20 seconds
Emergency Heat Staging Delay	2 minutes	7.5 seconds
Water Valve Slow Open Delay	90 seconds	90 seconds
Reheat Delay	30 seconds	30 seconds

Aurora LED Flash Codes					
<b>Slow Flash</b>	1 second on and 1 second off				
<b>Fast Flash</b>	100 milliseconds on and 100 milliseconds off				
<b>Flash Code</b>	100 milliseconds on and 400 milliseconds off with a 2 second pause before repeating				
Random Start Delay					
Status LED (LED1, Green)	Fast Flash				
Configuration LED (LED2, Yellow)	Fast Flash				
Fault LED (LED3, Red)	Fast Flash				
Status LED (LED1, Green)	Configuration LED (LED2, Yellow)	Fault LED (LED3, Red)			
Normal Mode	ON	No Software Override	Flash ECM Setting	Normal Mode	OFF
Control is Non-Functional	OFF	DIP Switch Override	Slow Flash	Input Fault Lockout	Flash Code 1
Test Mode	Slow Flash	ECM Configure Mode	Fast Flash	High Pressure Lockout	Flash Code 2
Lockout Active	Fast Flash	Reset Configure Mode	Off	Low Pressure Lockout	Flash Code 3
Dehumidification Mode	Flash Code 2			Low Air Coil Limit Lockout - FP2	Flash Code 4
Reserved	Flash Code 3			Low Water Coil Limit Lockout - FP1	Flash Code 5
Reserved	Flash Code 4			Reserved	Flash Code 6
Load Shed	Flash Code 5			Condensate Overflow Lockout	Flash Code 7
ESD	Flash Code 6			Over/Under Voltage Shutdown	Flash Code 8
Reserved	Flash Code 7			Reserved	Flash Code 9
				Reserved	Flash Code 10
				Air/Water Coil Limit Sensor Error	Flash Code 11

### Legend

Factory Low Voltage Wiring

Factory Line Voltage Wiring

Field Low Voltage Wiring

Field Line Voltage Wiring

Optional Block

DC Voltage PCB Traces

Field Zone Sensor Wiring

Internal Junction

Quick Connect Terminal

Field Wiring Lug

Ground

Relay Contacts - N.O., N.C.

Capacitor

Fuse

Temperature Switch

Thermistor

Relay Coil

Switch - Condensate Overflow

Switch - High pressure

Switch - Low pressure

Polarized connector

Light Emitting Diode - Green

Light Emitting Diode - Yellow

Light Emitting Diode - Red

Wire nut

SW1 - Push button

SW2 - DIP package 8 position

PB - Power Block

HP - High Pressure Switch

LP - Low Pressure Switch

FD - Freeze Detection Sensor

F1 - Fuse

### Notes:

- 1 - Swap blue and red leads for 208V operation.
- 2 - Factory wired. Refer to blower table settings.
- 3 - Use ALG Output for 24V lockout.

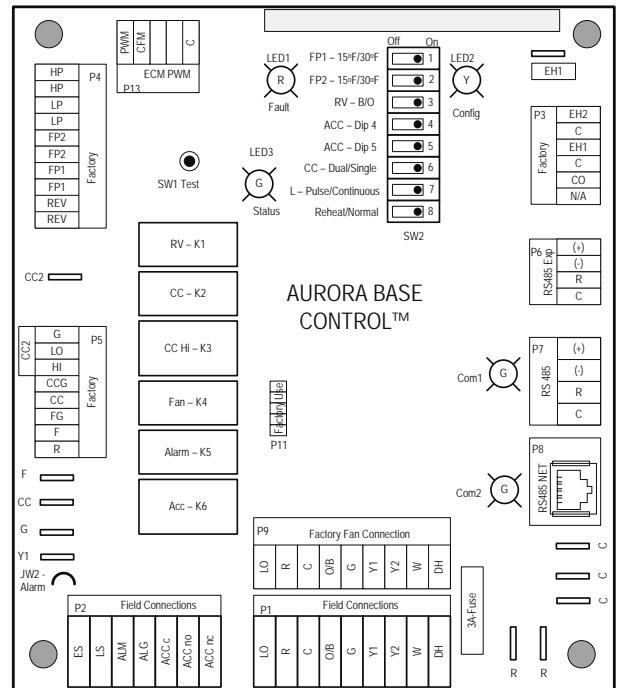

## Engineering Guide Specifications

### General

Furnish and install York Water Source Heat Pumps, as indicated on the plans. Equipment shall be completely assembled, piped and internally wired. Chassis shall be installed with factory built cabinet or other approved custom cabinet. Chassis SHALL NOT be installed without an approved cabinet enclosure. Capacities and characteristics as listed in the schedule and the specifications that follow. The reverse cycle heating/cooling units shall be floor mounted console type with horizontal air inlet and up-flow air discharge. Units shall be AHRI/ISO 13256-1 certified and listed by a nationally recognized safety-testing laboratory or agency, such as ETL Testing Laboratory. Each unit shall be computer run-tested at the factory with conditioned water and operation verified to catalog data. Each unit shall be mounted on a pallet and shipped in a corrugated box or stretch-wrapped. The units shall be designed to operate with entering liquid temperature between 20°F and 120°F [-6.7°C and 48.9°C].

### Chassis & Cabinet

The cabinet shall be fabricated from heavy-gauge galvanized steel and finished with a beige textured epoxy powder coating on both sides for added protection. This corrosion protection system shall meet the stringent 1000 hour salt spray test per ASTM B117.

The cabinet shall be easily removable to allow for ease of service to the controls compartment, chassis, and piping. The top of the cabinet and grille is a horizontally flat (optional sloped) surface with a hinged control door cover. The return air filter shall be 1" (25.4 mm) fiberglass disposable type media.

The return and supply air sections are insulated with a 1/4" (6.4 mm) thick, dual density, 2 lb/ft<sup>3</sup> (32 kg/m<sup>3</sup>) coated mat glass fiber with edges sealed or tucked under flanges to prevent the introduction of glass fibers into the discharge supply air through the aluminum grille. Standard cabinet panel insulation must meet NFPA 90A requirements, air erosion and mold growth limits of UL-181, stringent fungal resistance test per ASTM-C1071 and ASTM G21, and shall meet zero level bacteria growth per ASTM G22. Unit insulation must meet these stringent requirements or unit(s) will not be accepted.

**Option: A Super Quiet Sound package** shall include multi-density full coverage compressor blanket.

**Option: Shipped with motorized outside air damper and damper assembly for 25% make-up air.**

The drain pan shall be of stainless steel construction to inhibit corrosion and bacterial growth. Drain outlet shall be located on pan as to allow complete and unobstructed drainage of condensate. The unit as standard will be supplied with solid-state electronic condensate overflow protection with microprocessor. Mechanical float switches WILL NOT be accepted. Condensate tube shall be constructed of stainless steel and have an internal factory installed condensate trap.

### Refrigerant Circuit

All units shall utilize the non-ozone depleting and low global warming potential refrigerant R410A. All units shall contain a sealed refrigerant circuit including a hermetic motor-compressor, bi-directional thermostatic expansion valve, finned tube air-to-refrigerant heat exchanger, reversing valve, coaxial tube water-to-refrigerant heat exchanger, and service ports.

Compressors shall be high-efficiency single speed rotary type designed for heat pump duty and mounted on durometer grommets to provide vibration free compressor mounting. Compressor motors shall be single-phase ECM with internal overload protection.

The air coil shall be sized for low-face velocity and constructed of lanced aluminum fins bonded to rifled aluminum tubes in a staggered pattern not less than three rows deep for enhanced performance.

**Option: AlumiSeal electro-coated air coil.**

The coaxial water-to-refrigerant heat exchanger shall be designed for low water pressure drop and constructed of a convoluted copper (cupronickel option) inner tube and a steel outer tube. Refrigerant to air heat exchangers shall utilize enhanced corrugated lanced aluminum fins and rifled aluminum tube construction rated to withstand 600 psig (4135 kPa) refrigerant working pressure. Refrigerant-to-water heat exchangers shall be of copper inner water tube and steel refrigerant outer tube design, rated to withstand 600 psig (4135 kPa) working refrigerant pressure and 450 psig (3101 kPa) working water pressure. The thermostatic expansion valve shall provide proper superheat over the entire liquid temperature range with minimal "hunting." The valve shall operate bi-directionally without the use of check valves.

**Option: Cupro-nickel refrigerant to water heat exchanger** shall be of copper-nickel inner water tube and steel refrigerant outer tube design, rated to withstand 600 PSIG (4135 kPa) working refrigerant pressure and 450 PSIG (3101 kPa) working water pressure. Water lines shall also be of cupronickel construction.

**Option: ThermaShield coated water-to-refrigerant heat exchanger, water lines and refrigerant suction lines** shall be insulated to prevent condensation at low liquid temperatures below 50°F.

### Blower Motor & Assembly

The blower shall be a direct drive centrifugal type with a twin dynamically balanced wheel. The housing and wheel shall be designed for quiet, low outlet velocity operation. The blower housing shall be constructed of galvanized steel and shall be removable from the unit for servicing of the blower motor. The blower motor shall be a two-speed type and shall be isolated from the housing by rubber grommets. The motor shall be permanently lubricated and have thermal overload protection.

### Electrical

A control box shall be located within the unit compressor compartment and shall contain a 75VA transformer, 24 Volt activated, 2 pole compressor contactor, and solid-state controller for complete unit operation. Units shall be name-plated for use with time delay fuses or HACR circuit breakers. Unit controls shall be

## Engineering Guide Specifications cont.

24 Volt and provide heating or cooling as required by the remote thermostat/sensor.

Unit mounted controls shall consist of switches for "OFF", "FAN", and "AUTO" or "HEAT/COOL". An additional switch is provided for blower speed setting of "HI" or "LO". The unit shall be equipped with a blower switch on the side of the control to provide "CONTINUOUS" or "CYCLED" blower operation. "CYCLED" blower will turn the blower on with the compressor. A unit-mounted electronic thermostat with a remote electronic thermistor located in the return air will control compressor operation in heating and cooling modes. Unit mounted thermostat shall be the standard thermostat option. All unit mounted thermostats shall be auto changeover. Manual changeover WILL NOT be accepted. Electromechanical operation WILL NOT be accepted.

### Controls

**Standard: A compressor control module (CCM)** shall be included to disable compressor operation in the event of a trip of any of the safety switches and to send a signal to activate a fault indicator light at the thermostat. The CCM shall be capable of being reset from the thermostat or from the unit main disconnect switch. A terminal block with screw terminals shall be provided for field connection of all low-voltage wiring.

An Aurora microprocessor-based controller that interfaces with a multi-stage electronic thermostat to monitor and control unit operation shall be provided. The control shall provide operational sequencing, blower speed control, high and low pressure switch monitoring, freeze detection, condensate overflow sensing, lockout mode control, LED status and fault indicators, fault memory, field selectable options and accessory output. The control shall provide fault retry three times before locking out to limit nuisance trips. A detachable terminal block with screw terminals will be provided for field control wiring. All units shall have knockouts for entrance of low and line voltage wiring. The blower motor and control box shall be harness plug wired for easy removal.

**Option: Remote mounted thermostat** is available for CCM and Aurora Base Control. A terminal block with screw terminals will be provided for field control wiring.

### Piping

Supply and return water connections shall be 1/2 in. [12.7 mm] FPT copper threaded fittings. All water piping shall be insulated to prevent condensation at low liquid temperatures.

A stainless steel tube stubbed out from the chassis is provided for condensate drain attachment. A short piece of polyvinyl hose is supplied to assist in adapting to drain.

### Accessories

#### Hose Kits – Ball Valves (field-installed)

A flexible steel braid hose featuring Kevlar® reinforced EPDM core with ANSI 302/304 stainless steel outer braid and fire rated materials per ASTM E 84-00 (NFPA 255, ANSI/UL 723 & UBC 8-1). Ball valve at one end; swivel connector with adapter at the other end (swivel to adapter connection via fiber or EPDM gasket). Swivel connection provides union between heat pump and piping system. The hoses feature brass fittings, stainless steel ferrules.

A full port ball valve shall be provided with integral P/T (pressure/temperature) port on supply hose. Specifications: Temperature range of 35°F [2°C] to 180°F [82°C]. Max. working pressure of 400 psi [2757 kPa] for 1/2" and 3/4" hose kits; max. working pressure of 350 psi [kPa] for 1" and 1-1/4" hose kits.

#### Hose Kits - Automatic Balancing and Ball Valves (field-installed)

A flexible steel braid hose featuring Kevlar® reinforced EPDM core with ANSI 302/304 stainless steel outer braid and fire rated materials per ASTM E 84-00 (NFPA 255, ANSI/UL 723 & UBC 8-1). Ball valve at one end; swivel connector with adapter at the other end (swivel to adapter connection via fiber or EPDM gasket). Swivel connection provides union between heat pump and piping system. The hoses feature brass fittings, stainless steel ferrules. A full port ball valve shall be provided with integral P/T (pressure/temperature) port on supply hose and automatic balancing valve with integral P/T ports and full port ball valve on return hose. Specifications:

- Temperature range of 35°F [2°C] to 180°F [82°C].
- Max. working pressure of 400 psi [2757 kPa] for 1/2" and 3/4" hose kits; max. working pressure of 350 psi [2413 kPa] for 1" and 1-1/4" hose kits.
- Minimum burst pressure of four times working pressure.

#### Hose Kits – Automatic Balancing and Ball Valves with 'Y' strainer (field-installed)

A flexible steel braid hose featuring Kevlar® reinforced EPDM core with ANSI 302/304 stainless steel outer braid and fire rated materials per ASTM E 84-00 (NFPA 255, ANSI/UL 723 & UBC 8-1). Ball valve at one end; swivel connector with adapter at the other end (swivel to adapter connection via fiber or EPDM gasket). Swivel connection provides union between heat pump and piping system. The hoses feature brass fittings, stainless steel ferrules. A "y" strainer is provided on one end for fluid straining and integral "blowdown" valve.. A full port ball valve shall be provided with integral P/T (pressure/temperature) port on supply hose and automatic balancing valve with integral P/T ports and full port ball valve on return hose.

Specifications:

- Temperature range of 35°F [2°C] to 180°F [82°C].
- Max. working pressure of 400 psi [2757 kPa] for 1/2" and 3/4" hose kits; max. working pressure of 350 psi [2413 kPa] for 1" and 1-1/4" hose kits.
- Minimum burst pressure of four times working pressure.

#### Auxiliary Heater (field-installed 208-230V units only)

An electric resistance heater shall provide supplemental and/or emergency heating capability. A manual switch shall be mounted on the side of the control compartment with "NORMAL" or "BOILERLESS" mode. "NORMAL" will run the compressor when there is a call for heating or cooling. "BOILERLESS" mode operation will run electric heat whenever there is a call for heating and run the compressor for a cooling call.

## Notes

---



## Revision Guide

---

<b>Pages:</b>	<b>Description:</b>	<b>Date:</b>	<b>By:</b>
All	Updated Nomenclature and Wiring Schematics (ABC Controls)	1 Sept 2015	MA
All	Obsoleted PSC Option, Updated Nomenclature, Updated Wiring Schematics	04 Mar 2015	MA
All	Updated with All-Aluminum Air Coils	10 Mar 2014	DS
All	First Published	30 Oct 2013	DS



Product: **Affinity Console Series**  
Type: Geothermal/Water Source Heat Pumps  
Size: 0.75-1.5 Ton

Document Type: Specification Catalog  
Part Number: SC101CK6B  
Release Date: 09/15