



Heating and Air Conditioning

INSTALLATION MANUAL

AFFINITY *OptiHeat*

GEOHERMAL HEAT PUMPS

SINGLE SPEED HYDRONIC

WITH VAPOR INJECTION

MODELS:

YAW040 - 066

(3 THRU 5 NOMINAL TONS)



Due to continuous product improvement,
specifications are subject to change without notice.

Visit us on the web at www.york-geothermal.com

Additional rating information can found at
www.ahridirectory.org

FOR DISTRIBUTION USE ONLY - NOT TO BE USED AT POINT OF RETAIL SALE

Table of Contents

Model Nomenclature	4
General Installation Information	5
Field Connected Water Piping	6
Flow Centers	11
Electrical Information	12
Hydronic Section	16
External Control	19
Accessories and Options	20
Electrical Data	22
Wiring Schematics	24
Unit Startup	26
Aurora Base Control	28
Reference Calculations	36
Legend and Notes	36
Water Pressure Drop	37
Pressure Drop	38
Operating Limits	39
Physical Data	39
Flow Rates	39
Heating & Cooling Operating Envelope	40
Thermistor and Compressor Resistance	41
Operating Parameters	41
Antifreeze Correction	43
Troubleshooting Guideline for Refrigerant Circuit	44
HR Data	45
HE Data	46
OptiHeat Sensor Location	47
Heating and Cooling Cycle Analysis	48
Troubleshooting Form	49
Troubleshooting	50
Preventive Maintenance	51
Service Parts	52
Revision Guide	55

Model Nomenclature

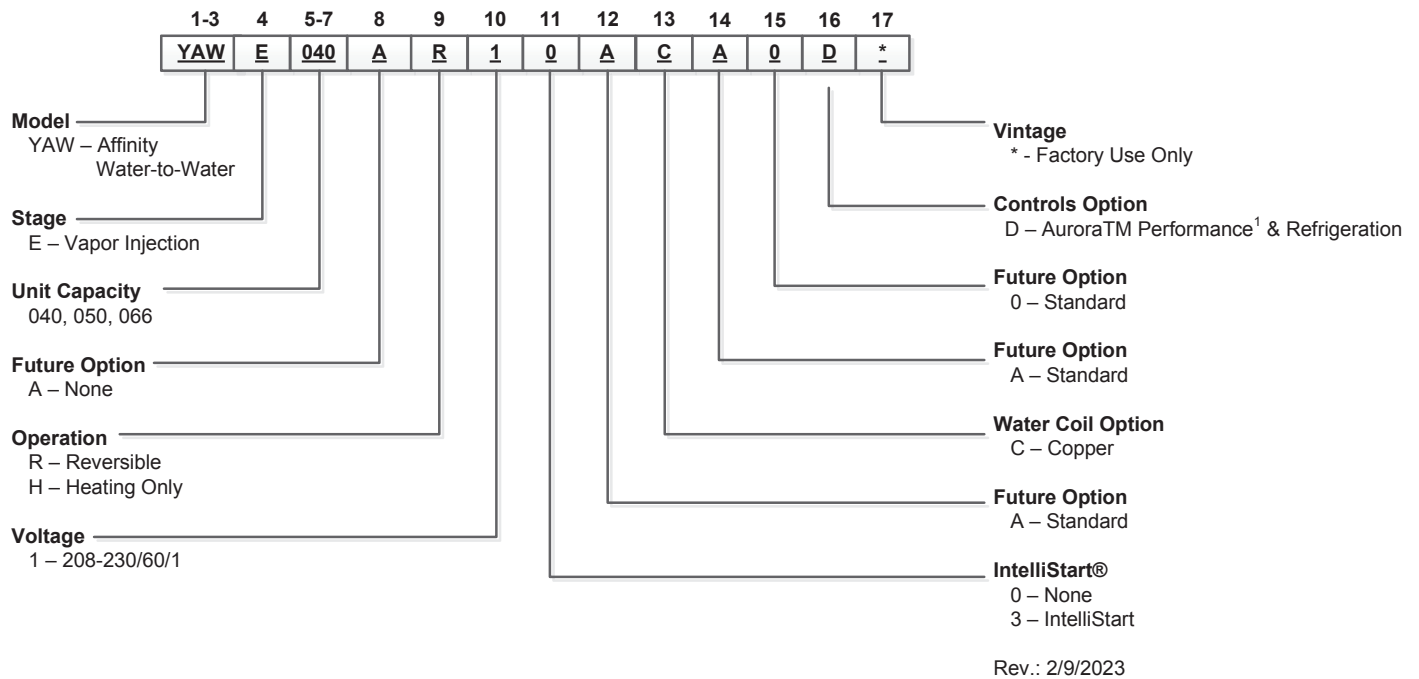

NOTES: 1 – Flow meter for Performance and Refrigeration option is shipped inside the unit and must be externally field installed.



All Affinity Single Stage Hydronic with OptiHeat product is safety listed under UL1995 thru ETL and performance listed with AHRI in accordance with standard 13256-1. The Affinity Single Stage Hydronic with OptiHeat is also ENERGY STAR® rated.

General Installation Information

Safety Considerations

Installing and servicing air conditioning and heating equipment can be hazardous due to system pressure and electrical components. Only trained and qualified service personnel should install, repair or service heating and air conditioning equipment. When working on heating and air conditioning equipment, observe precautions in the literature, tags and labels attached to the unit and other safety precautions that may apply.

Follow all safety codes. Wear safety glasses and work gloves. Use quenching cloth for brazing operations. Have fire extinguisher available for all brazing operations.

NOTE: Before installing, check voltage of unit(s) to ensure proper voltage.



WARNING: Before performing service or maintenance operations on the system, turn off main power switches to the unit. Electrical shock could cause serious personal injury.



WARNING: This heat pump is capable of producing hot water up to 150°F. All exposed piping surfaces shall be insulated to prevent serious personal injury that can occur from touching water piping.

Application

Units are not intended for heating domestic (potable) water or swimming pools by direct coupling. If used for this type of application, a secondary heat exchanger must be used.

An indirect water heater directly coupled to the unit as the secondary heat exchanger is not recommended. The heating capacity of this equipment is too large for the extremely small amount of water located in the coils of the indirect water heater. A storage tank of adequate size (see guidelines in this manual) should be used ahead of the indirect water heater to reduce the risk of short cycling, high head pressure faults, and compressor thermal overload trips.

Application where there is either a boiler backup or a second water to water heat pump isolation valves need to be installed to eliminate source and load water flow from going through the heat pump when it is not operating. Most boiler applications are over 145°F. Running source and load water flow through the heat pump when it is off could be detrimental to the long-term reliability of the compressor. (Refer to guidelines in this manual)

The use of HydroStat (HSC) or HydroZone (HZA, HZO) are recommended for controlling the storage tank temperature and heat pump control. When using third party controls special attention needs to be made so that the leaving load temperature never exceeds 145°F. You may have to increase the load water flow or decrease the set point. You also need to look at leaving load temperatures over the source water operating range to ensure the leaving load temperature never exceed 145°F. Care also needs to be taken to ensure that the heat pump is not constantly cycling on and off. 4-minute anti-short cycle and 2-minute minimum compressor run time. Constant cycling of the compressor will reduce the reliability of the compressor.

Moving and Storage

Move units in the normal “Up” orientation as indicated by the labels on the unit packaging. When the equipment is received, all items should be carefully checked against the bill of lading to ensure that all crates and cartons have been received in good condition. Examine units for shipping damage, removing unit packaging if necessary to properly inspect unit. Units in question should also be internally inspected. If any damage is observed, the carrier should make the proper notation on delivery receipt acknowledging the damage. Units are to be stored in a location that provides adequate protection from dirt, debris and moisture.



WARNING: To avoid equipment damage, do not leave the system filled in a building without heat during cold weather, unless adequate freeze protection levels of antifreeze are used. Heat exchangers do not fully drain and will freeze unless protected, causing permanent damage.

Unit Location

Provide sufficient room to make water and electrical connections. If the unit is located in a confined space, provisions must be made for unit servicing. Locate the unit in an indoor area that allows easy removal of the access panels and has enough space for service personnel to perform maintenance or repair. These units are not approved for outdoor installation and, therefore, must be installed inside a structure being conditioned. Do not locate units in areas subject to freezing conditions.

Field Connected Water Piping



WARNING: Do not store or install units in corrosive environments or in locations subject to temperature or humidity extremes (e.g. attics, garages, rooftops, etc.). Corrosive conditions and high temperature or humidity can significantly reduce performance, reliability, and service life.

Mounting Units

Prior to setting the unit in place, remove and discard the compressor hold down shipping bolt located at the front of each compressor mounting bracket. Units should be mounted level on a vibration absorbing pad slightly larger than the base to provide isolation between the unit and the floor. It is not necessary to anchor the unit to the floor. Allow access to the front, back, top and side access panels for servicing.

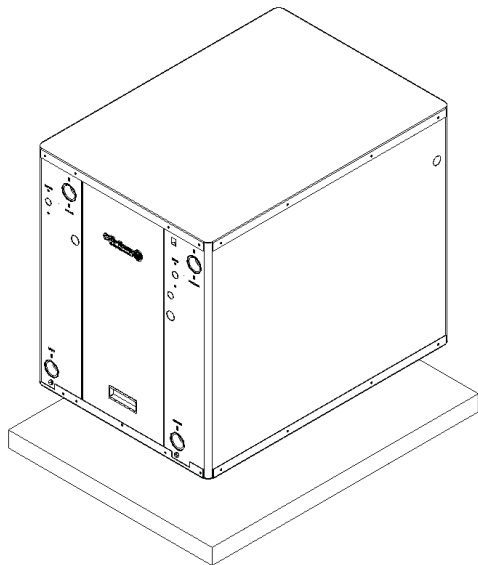

Vibration Pad Mounting

General

Each unit is equipped with captive FPT water connections to eliminate 'egg-shaping' from use of a backup wrench. For making the water connections to the unit, a Teflon tape thread sealant is recommended to minimize internal fouling of the piping. Do not over tighten connections. All supply and return water piping should be insulated to prevent excess condensation from forming on the water lines.

NOTE: Units are factory run-tested using propylene glycol. Prior to connecting piping to unit, thoroughly flush heat exchangers.

The piping installation should provide service personnel with the ability to measure water temperatures and pressures. The water lines should be routed so as not to interfere with access to the unit. The use of a short length of high pressure hose with a swivel type fitting may simplify the connections and prevent vibration. Optional stainless steel hose kits are available as an accessory item.

Before final connection to the unit, the supply and return hose kits must be connected, and the system flushed to remove dirt, piping chips and other foreign material. Normally, a combination balancing and close-off (ball) valve is installed at the return, and a rated gate or ball valve is installed at the supply. The return valve can be adjusted to obtain the proper water flow. The valves allow the unit to be removed for servicing.

The proper water flow must be delivered to each unit whenever the unit heats or cools. To assure proper flow, the use of pressure/temperature ports is recommended to determine the flow rate. These ports should be located adjacent to the supply and return connections on the unit. The proper flow rate cannot be accurately set without measuring the water pressure drop through the refrigerant-to-water heat exchanger (See Pressure Drop Table for water flow and pressure drop information). Normally about 3 GPM flow rate per ton of cooling capacity (2.25 GPM per ton minimum) is needed. Both source as well as load fluid piping must be at least as large as the unit connections on the heat pump (larger on long runs).

Never use flexible hoses of a smaller inside diameter than that of the water connection on the unit and limit hose length to 10 ft. per connection. Check carefully for water leaks.



CAUTION: Water piping exposed to outside temperature may be subject to freezing.

Water Quality

It is the responsibility of the system designer and installing contractor to ensure that acceptable water quality is present and that all applicable codes have been met in these installations. Failure to adhere to the guidelines in the water quality table could result in loss of warranty. In ground water situations where scaling could be heavy or where biological growth such as iron bacteria will be present, a closed loop system is recommended. The heat exchanger coils in ground water systems may, over a period of time, lose heat exchange capabilities due to a buildup of mineral deposits inside. These can be cleaned, but only by a qualified service mechanic, as special solutions and pumping equipment are required. Hot water generator coils can likewise become scaled and possibly plugged. In areas with extremely hard water, the owner should be informed that the heat exchanger may require occasional flushing.

Heat pumps with cupronickel heat exchangers are recommended for open loop applications due to the increased resistance to build-up and corrosion, along with reduced wear caused by acid cleaning.

Field Connected Water Piping cont.

Material		Copper	90/10 Cupronickel	316 Stainless Steel
pH	Acidity/Alkalinity	7 - 9	7 - 9	7 - 9
Scaling	Calcium and Magnesium Carbonate	(Total Hardness) less than 350 ppm	(Total Hardness) less than 350 ppm	(Total Hardness) less than 350 ppm
Corrosion	Hydrogen Sulfide	Less than 0.5 ppm (rotten egg smell appears at 0.5 ppm)	10 - 50 ppm	Less than 1 ppm
	Sulfates	Less than 125 ppm	Less than 125 ppm	Less than 200 ppm
	Chlorine	Less than 0.5 ppm	Less than 0.5 ppm	Less than 0.5 ppm
	Chlorides	Less than 20 ppm	Less than 125 ppm	Less than 300 ppm
	Carbon Dioxide	Less than 50 ppm	10 - 50 ppm	10 - 50 ppm
	Ammonia	Less than 2 ppm	Less than 2 ppm	Less than 20 ppm
	Ammonia Chloride	Less than 0.5 ppm	Less than 0.5 ppm	Less than 0.5 ppm
	Ammonia Nitrate	Less than 0.5 ppm	Less than 0.5 ppm	Less than 0.5 ppm
	Ammonia Hydroxide	Less than 0.5 ppm	Less than 0.5 ppm	Less than 0.5 ppm
	Ammonia Sulfate	Less than 0.5 ppm	Less than 0.5 ppm	Less than 0.5 ppm
	Total Dissolved Solids (TDS)	Less than 1000 ppm	1000 - 1500 ppm	1000 - 1500 ppm
	LSI Index	+0.5 to -0.5	+0.5 to -0.5	+0.5 to -0.5
Iron Fouling (Biological Growth)	Iron, FE ²⁺ (Ferrous) Bacterial Iron Potential	< 0.2 ppm	< 0.2 ppm	< 0.2 ppm
	Iron Oxide	Less than 1 ppm, above this level deposition will occur	Less than 1 ppm, above this level deposition will occur	Less than 1 ppm, above this level deposition will occur
Erosion	Suspended Solids	Less than 10 ppm and filtered for max. of 600 micron size	Less than 10 ppm and filtered for max. of 600 micron size	Less than 10 ppm and filtered for max. of 600 micron size
	Threshold Velocity (Fresh Water)	< 6 ft/sec	< 6 ft/sec	< 6 ft/sec

NOTES: Grains = ppm divided by 17 mg/L is equivalent to ppm

2/22/12

Water Treatment

Do not use untreated or improperly treated water. Equipment damage may occur. The use of improperly treated or untreated water in this equipment may result in scaling, erosion, corrosion, algae or slime. Purchase of a pre-mix antifreeze could significantly improve system reliability if the water quality is controlled and there are additives in the mixture to inhibit corrosion. There are many examples of such fluids on the market today such as Environol™ 1000 (pre-mix ethanol), and others. The services of a qualified water treatment specialist should be engaged to determine what treatment, if any, is required. The product warranty specifically excludes liability for corrosion, erosion or deterioration of equipment.

The heat exchangers and water lines in the units are copper or cupronickel tube. There may be other materials in the buildings piping system that the designer may need to take into consideration when deciding the parameters of the water quality. If antifreeze or water treatment solution is to be used, the designer should confirm it does not have a detrimental effect on the materials in the system.

Contaminated Water

In applications where the water quality cannot be held to prescribed limits, the use of a secondary heat exchanger is recommended to separate the unit from the contaminated water. The table above outlines the water quality guidelines for unit heat exchangers. If these conditions are exceeded, a secondary heat exchanger is required. Failure to supply a secondary heat exchanger where needed will result in a warranty exclusion for primary heat exchanger corrosion or failure.



WARNING: Must have intermediate heat exchanger when used in pool and spa applications.

Field Connected Water Piping cont.

Open Loop Well Water Systems

Always maintain water pressure in the heat exchanger by placing water control valves at the outlet of the unit. Use a closed bladder type expansion tank to minimize mineral deposits. Ensure proper water flow through the unit by checking pressure drop across the heat exchanger and comparing it to the figures in the pressure drop table. Normally, about 2 GPM flow rate per ton of cooling capacity is needed in open loop systems, (1.5 GPM per ton minimum if entering source temperature is above 50°F [10°C]).

Some water control valves draw their power directly from the unit's 24V transformer and can overload and possibly burn out the transformer. Check total VA draw of the water valve(s) and ensure it is under 40 VA.

Discharge water from a heat pump can be disposed of in various ways depending on local building codes (i.e. recharge well, storm sewer, drain field, adjacent stream or pond, etc.). Most local codes restrict the use of sanitary sewer for disposal. Consult your local building and zoning departments to ensure compliance in your area.

Figure 1a: Open Loop Solenoid Valve Connection Option

Typical quick operating external 24V water solenoid valve (type PPV100 or BPV100) wiring.

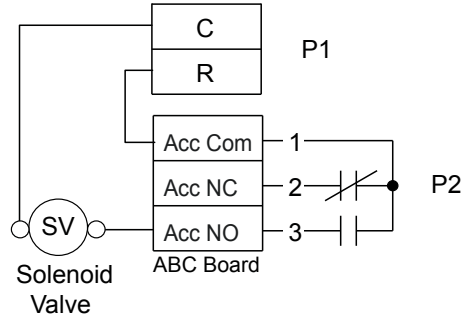

NOTE: SW2-4 and SW2-5 should be "OFF" to cycle with the compressor.

Figure 1b: Open Loop Solenoid Valve Connection Option

Typical slow operating external 24V water solenoid valve (type V100FPT) wiring.

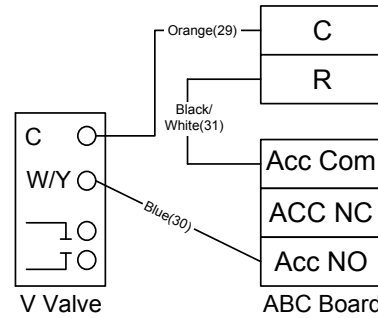

NOTE: SW2-4 should be "ON" and SW2-5 should be "OFF" when using a slow opening (V100FPT) water valve.

Typical Open Loop Installation

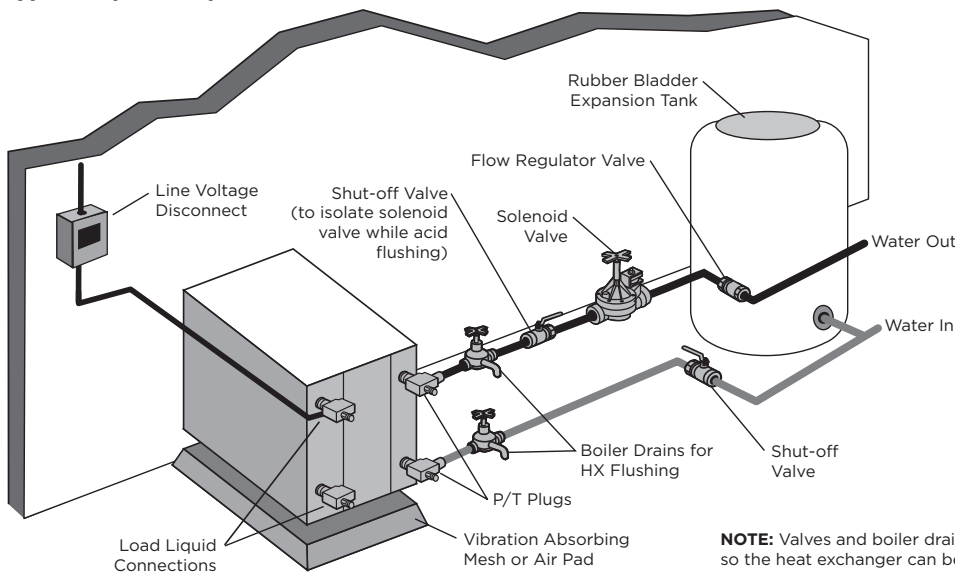

NOTE: Valves and boiler drains must be installed so the heat exchanger can be acid flushed.

Field Connected Water Piping cont.

Modulating Water Valve Setup

When using a modulating water valve kit (4MWVK or 5MWVK) the use of an AID Tool will be necessary to adjust minimum and maximum flow rates. The factory default is minimum = 70% and maximum = 100% flow levels. **Since the OptiHeat is a single speed unit, the minimum and maximum must be set at the same level.** See the Variable Speed Pump Setup and Modulating Water Valve Setup instructions within the Unit Startup section which is located in the back of this manual. Refer to the Flow Rate section of this manual to ensure that there is adequate flow for the heat pump.

Modulating Water Valve Connection Option

4MWVK Wiring

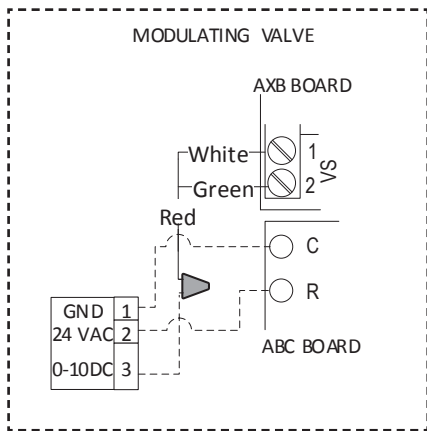

5MWVK Wiring

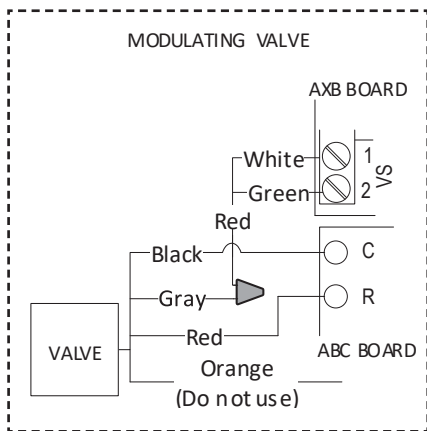

Earth Coupled Systems with Flow Center

NOTE: For closed loop systems with antifreeze protection, set SW2-1 to the "LOOP" (15°F) position. (Refer to the DIP Switch Settings table in the Aurora Control section.)

Once piping is completed between the unit, pumps and the ground loop (see figure below), final purging and charging of the loop is required. A flush cart (or a 1.5 HP pump minimum) is needed to achieve adequate flow velocity in the loop to purge air and dirt particles from the loop itself. Antifreeze solution is used in most areas to prevent freezing. Flush the system adequately to remove as much air as possible then pressurize the loop to a static pressure of 40-50 psi (summer) or 50-75 psi (winter). This is normally adequate for good system operation. Loop static pressure will fluctuate with the seasons. Pressures will be higher in the winter months than during the cooling season. This fluctuation is normal and should be considered when initially charging the system.

After pressurization, be sure to turn the venting (burping) screw in the center of the pump two (2) turns open (water will drip out), wait until all air is purged from the pump, then tighten the plug. Ensure that the flow center provides adequate flow through the unit by checking pressure drop across the heat exchanger and by comparing it to the figures shown in the Pressure Drop tables. Usually 3 GPM/ton or minimum 2.25 GPM/ton of cooling capacity is needed in closed loop earth-coupled applications.

Typical Closed Loop Earth Coupled Installation

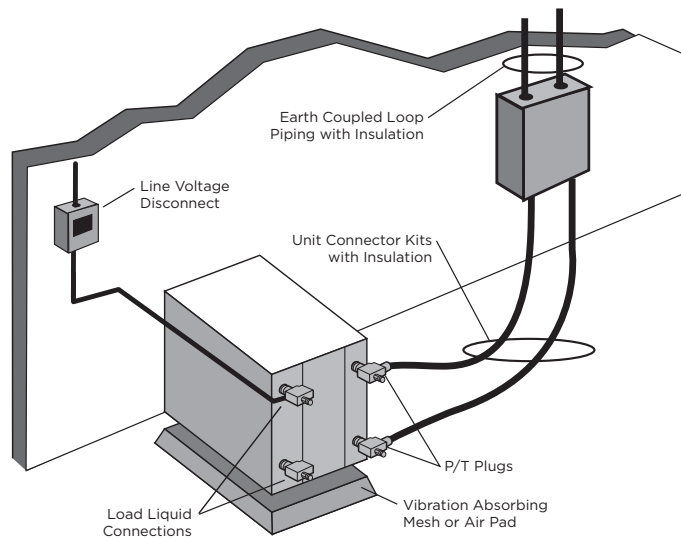

Field Connected Water Piping cont.

Multiple Units on One Flow Center

NOTE: This feature is only available in the Aurora Advanced Control package (AXB board), NOT the Aurora Base Control (ABC).

When two units are connected to one loop pumping system, pump control is automatically achieved by connecting the SL terminals on connector P2 in both units with 2-wire thermostat wire. These terminals are polarity dependant (see Figure 2). The loop pump(s) may be powered from either unit, whichever is more convenient. If either unit calls, the loop pump(s) will automatically start. The use of two units on one flow center is generally limited to a total of 20 gpm capacity. It is recommended that water solenoid valves be installed on heat pumps that share a flow center. This is to allow water flow through only the heat pump that has a demand. Circulating fluid through a heat exchanger of a system that is not operating could be detrimental to the long term reliability of the compressor.

Figure 2: Primary/Secondary Hook-up

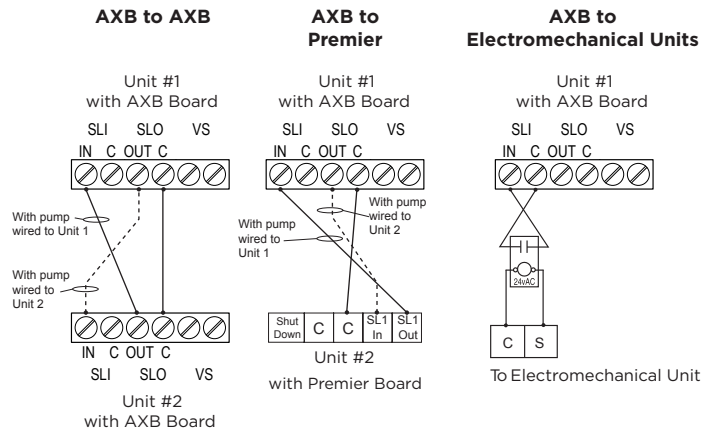

Variable Speed Pump Setup

When using a variable speed pump flow center (FCV Type) the use of an AID Tool will be necessary to adjust minimum and maximum flow rates. The factory default is minimum = 75% and maximum 100% flow levels. Since the OptiHeat is a single speed unit, the minimum and maximum must be set at the same level. See the Variable Speed Pump Setup and Modulating Water Valve Setup instructions within the Unit Startup section which is located in the back of this manual. Refer to the Flow Rate section of this manual to ensure that there is adequate flow for the heat pump.

Applications that have multiple OptiHeat units or alternate source as backup you must install valving on the load side of the system to stop water flow when the unit is not in operation. Water flowing thru the load side COAX can cause liquid refrigerant to migrate. Once the compressor turns on the liquid refrigerant can flood the compressor and wash oil out of the compressor.

Flow Centers

Pressurized Flow Centers:

- Part numbers: FC1-GL, FC2-GL, FC1-FPT, FC2-FPT,FCV1B-GL, FCV2B-GL
- Used with one or two one or multiple heat pumps on a single loop (need to follow installation manual and install check valves)
- Fixed speed and variable speed pumping available.
- Small footprint for mounting location flexibility.
- Can be mounted in several orientations (see flow center manual for acceptable orientations)
- Injection molded and insulated cabinet
- Brass 3-way valves
- Standard hose kits available

Non-Pressurized Flow Center:

- Part numbers: FC1-GLNP, FC2-GLNP, FCV1B-GLNPP, FCV2B-GLNPP
- Used with a single heat pump on a single loop (or two units if using pump sharing feature). Multiple units cannot be installed in parallel with multiple heat pumps on the same loop.
- Fixed speed and variable speed pumping available.
- Floor mounted (larger footprint than pressurized flow centers)
- Design allows for air and debris separation, and easy fluid checking or addition
- Insulated plastic cabinet
- Composite 3-way valves
- GLNPP flow centers use standard hose kit

Non-Pressurized Dual Circuit Flow Centers:

- Part numbers: FC3-GLNPD, FC4-GLNPD, FCV2AB-GLNPD, FCV2BB-GLNPD, FCV3CB-GLNPD, FCV4AB-GLNPD
- Designed for applications with two geothermal heat pumps by eliminating the need for T's, additional piping, check valves, and pump sharing wiring.
- Multiple pump configurations (fixed and variable speed) to match your flow requirements.
- Insulated sheet metal cabinet
- Brass and composite 3-way valves
- Design allows for air and debris separation, and easy fluid checking or addition
- Floor mounted (larger footprint than pressurized flow centers)
- Standard hose kits available

Electrical Information

Fixed Speed Flow Center

The pump(s) will be connected to the terminals on PB1 in the unit electrical box as shown in Figure 3a. The pumps will automatically be cycled as required by the unit or by a signal from another unit sharing the flow center (See Figures 5 and 6). Pumps are protected by circuit breakers (CB) shown in Figure 3a.

Figure 3a: Unit Wiring for Loop Pumps

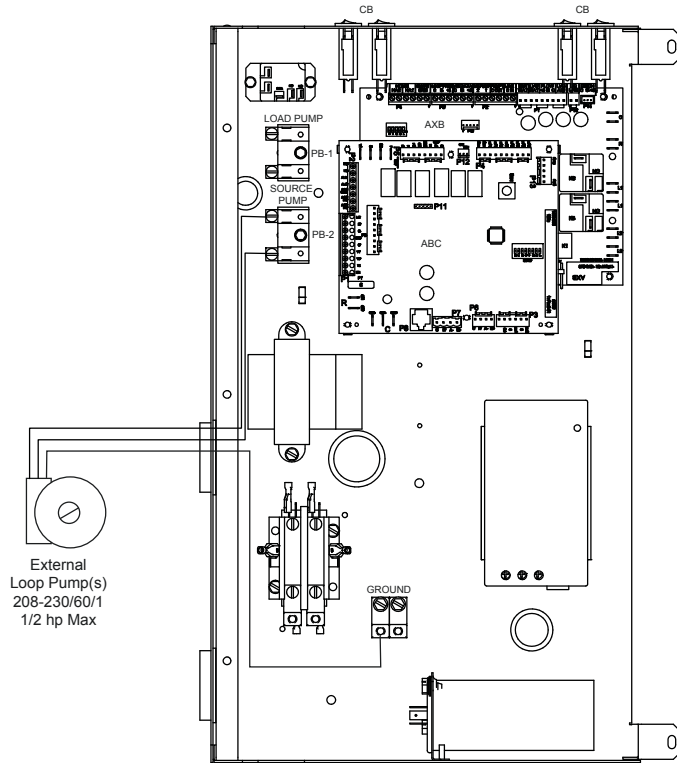

NOTES: For closed loop systems with antifreeze protection, set SW2 DIP Switch #1 to the "Loop" position on units with the Aurora control and SW2-2 should be set to "Loop" on the Premier control.

Figure 3c: FCM and FCL Flow Center Wiring (Not Referenced)

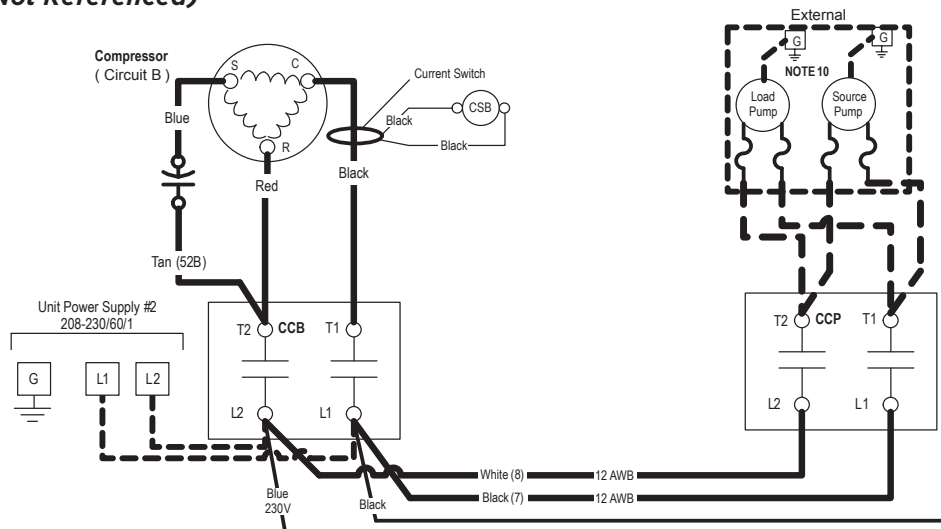

NOTES: FCM and FCL Flow Centers must be wired to a separate contactor (20 amp minimum). The HydroZone Accessory Control Box works best for this application.

Electrical Information cont.

Variable Speed Flow Center

Single Pump Variable Speed Flow Center

If a variable speed single pump flow center is used, the flow center will come with two red and one green wires for the high voltage wiring. The variable speed pump **MUST** be powered at all times and therefore **MUST** be wired to the “L” side of electrical system or damage to the pump will occur (pump cannot be powered from “T” side of compressor contactor). Connect the red HIGH VOLTAGE wires to L1 and L2 on the AXB, connect the green GROUND wire to the ground lug, as shown in figure 4a. Follow all electrical and local codes for wiring.

The variable speed UPMXL 25-124 pump also requires a low voltage signal to operate properly, if the low voltage signal isn't present the pump will run at 100%. Route the low voltage harness connected to the pump to the AXB screw terminals on P2 and P3 connectors per diagram 4b.

Both the low and high voltage harnesses are labeled. The pump will be automatically cycled as required either by the unit or by a signal from another unit sharing the same flow center. Pumps are protected by circuit breakers as shown on the unit schematic.

Figure 4a: Single VS Pump High Voltage Wiring

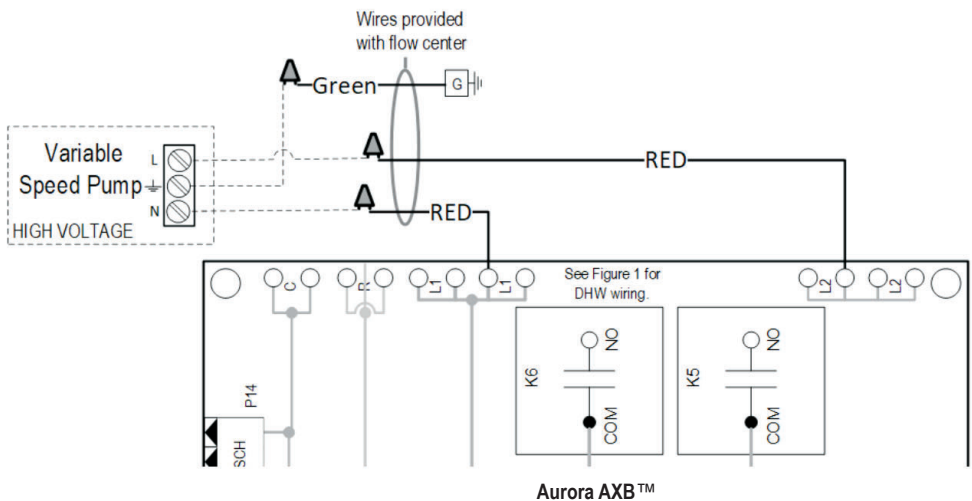
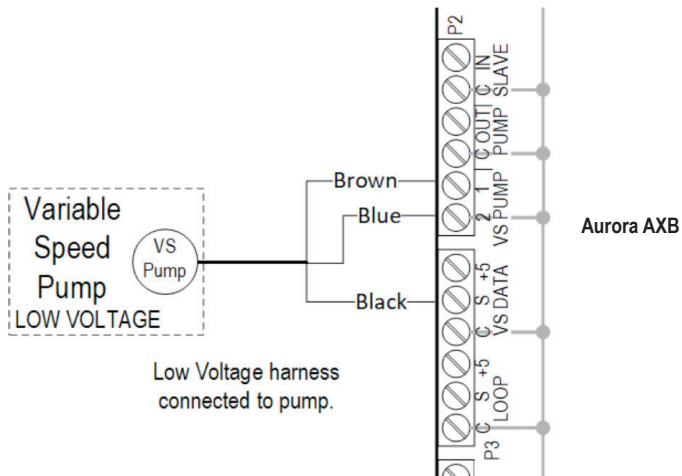

Figure 4b: Single VS Pump Low Voltage Wiring



Note: Aurora AXB must be used to control the UPMXL 25-124 pump.

Electrical Information cont.

Variable Speed Flow Center cont.

Two Pump Variable Speed Flow Center

If a variable speed two pump flow center is used, the flow center will come with four red and two green wires for the high voltage wiring. The second set of (2) red and (1) green wires is provided for installation flexibility. The variable speed pump **MUST** be powered at all times and therefore **MUST** be wired to the “L” side of electrical system or damage to the pump will occur (pump cannot be powered from “T” side of compressor contactor). The UPMXL 25-124 pump has screw terminals for the high voltage connection. Connect the red HIGH VOLTAGE wires to L1 and L2 on the AXB, connect the green GROUND wire to the ground lug, as shown in figure 4d. Follow all electrical and local codes for wiring.

The variable speed UPMXL 25-124 pump also requires a low voltage signal to operate properly, if the low voltage signal isn't present the pump will run at 100%. Route the low voltage harness connected to the right hand pump to the AXB screw terminals on P2 and P3 connectors. Route the low voltage harness connected to the left hand pump to the AXB screw terminals on P2 and P3 connector per figure 4c. The black wire on the left hand pump will have a label on it that reads **“DO NOT CONNECT THIS WIRE. ONLY ONE VS PUMP FEEDBACK SIGNAL CAN BE CONNECTED TO AXB BOARD”**.

Both the low and high voltage harnesses are labeled. The pump will be automatically cycled as required either by the unit or by a signal from another unit sharing the same flow center. Pumps are protected by circuit breakers as shown on the unit schematic.

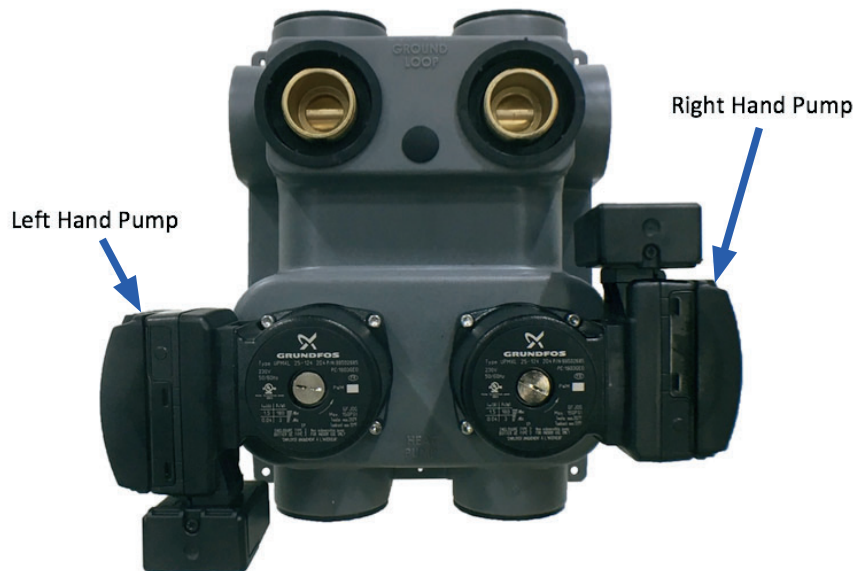

NOTE: Both pumps will speed up and slow down together.

Electrical Information cont.

Variable Speed Units cont.

Two Pump Variable Speed Flow Center cont.

The use of the black wire on the left hand pump is ONLY to be connected for troubleshooting of the pumps. The left hand pump will have a closed end splice connector crimped to the black wire. Cut the closed end splice connector off and strip the wire. During troubleshooting remove the black wire from the right hand pump from the AXB P3 VS DATA S screw terminal and connect the black wire from the left hand pump to the same location. After the troubleshooting is complete remove the black wire from the left hand pump and connect the black wire from the right hand pump.

Place electrical tape or wire nut on the left hand pump black wire. The two pump variable speed flow center cannot have each UPMXL 25-124 pump wired to two separate heat pumps otherwise damage to the pumps will occur (unless it's an NPD Series flow center).

Figure 4c: Two VS Pump Low Voltage Wiring

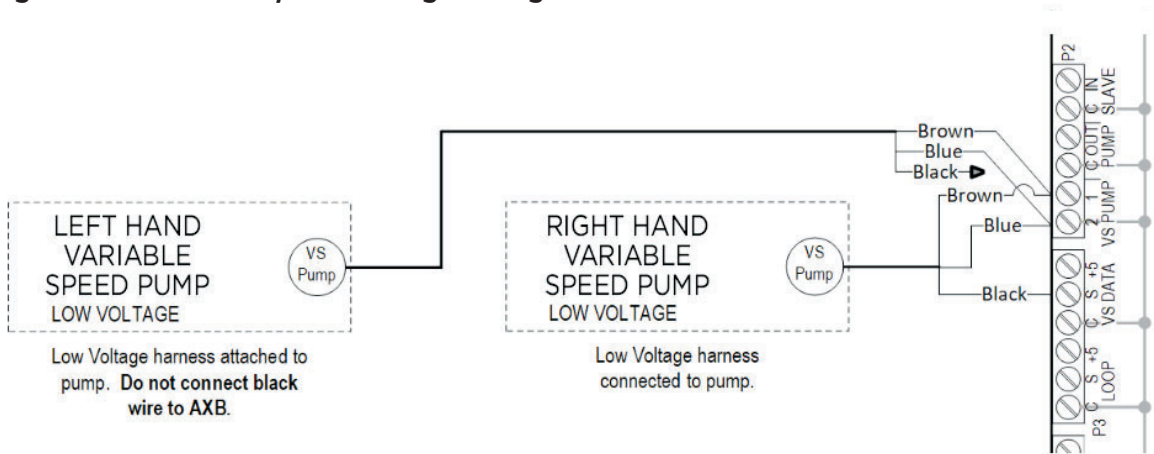

Note: Aurora AXB must be used to control the UPMXL 25-124 pump.

Figure 4d: Two VS Pump High Voltage Wiring

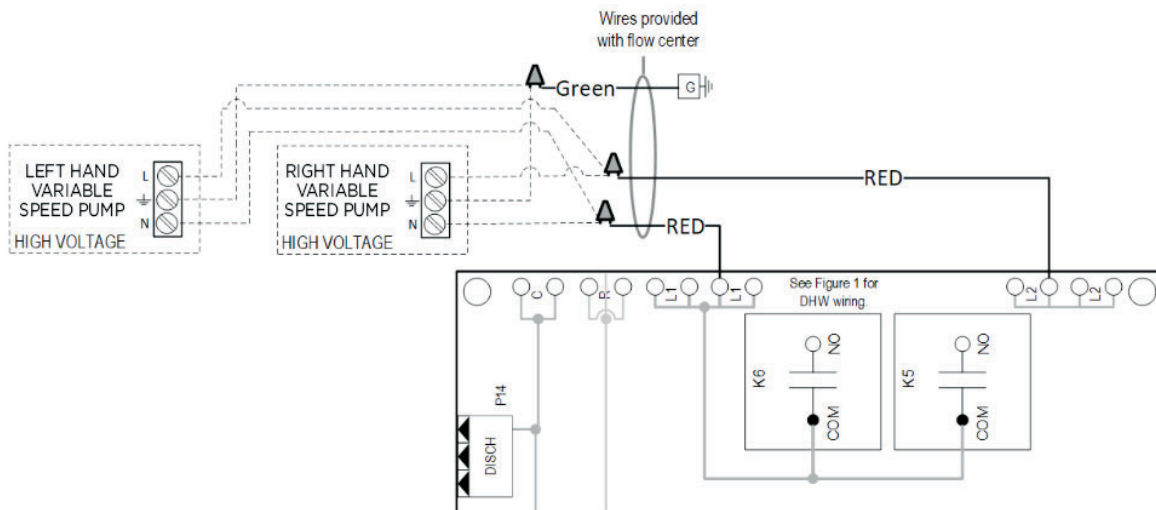

Hydronic Section

General guidelines are shown below for component selection and design/installation criteria for the piping system. Local codes supersede any recommendations in this manual.

Shut Off/Flow Regulation Valves

Use full port ball valves or gate valves for component isolation. If valves are going to be used frequently, ball valves are recommended. Globe valves are designed for flow regulation. Always install globe valves in the correct direction (fluid should enter through the lower body chamber).

Check valves

Swing check valves must be installed in the horizontal position with the bonnet of the valve upright. Spring check valves can be mounted in any position. A flow check valve is required to prevent thermo-siphoning (or gravity flow) when the circulator pump is off or when there are two circulators on the same system.

Storage (Buffer) Tank

A buffer tank is required for all hydronic heating systems using OptiHeat heat pumps. The tank should be sized to provide a minimum of 2 gallons of storage capacity for every one thousand Btuh's of nominal heat pump capacity. Sizing in this manner will provide the proper amount of heat pump cycling and storage.

Pressure Relief Valve

Most codes require the use of a pressure relief valve if a closed loop heat source can be isolated by valves. Even if local code does not require this device, the manufacturer recommends its installation. If the pressure relief valve in the buffer tank is not already rated at 30 psi (207 kPa) maximum pressure, one must be installed. The pressure relief valve should be tested at start up for operation. Note that the waste pipe must be at least the same diameter as the valve outlet (never reduce), and valves may not be added to this pipe. The bottom of the pipe must terminate at least 6" (15 cm) above the floor. If the piping is connected to a drain, there must be an air gap.

Backflow Prevention Check Valves

Most codes require backflow prevention check valves. Note that a single check valve is not equal to a backflow prevention check valve. Even if local code does not require this device, The manufacturer recommends its installation. This is particularly important if the system will use antifreeze.

Pressure Reducing Valves or Feed Water Valves

This valve lowers the pressure from the make-up water line to the system. Most are adjustable and directional. A "fast fill" valve is required for initial filling of the system. Some have screens, which must be cleaned after the initial filling. If there is a restriction in the screen, the system could go to 0 psi (0 kPa), potentially causing pumps(s) failure. A valve should be installed on each side of the pressure reducing valve for servicing. Both valves should have tags reading "Do not shut this valve under normal operation - service valve only."

Expansion Tanks

Expansion tanks are required on hydronic systems to help absorb the pressure swings as the temperature in the system fluctuates.

Elbows/Tees

Long radius elbows or two 45° elbows will lower pressure drop. Standard tees have a greater restriction on the "T" portion than tees designed with angled outlet ports.

Antifreeze

Antifreeze is required if any of the piping system is located in areas subject to freezing.

Dielectric Unions

Dielectric unions are recommended whenever connecting two dissimilar metals together to prevent electro-galvanic corrosion.

When using the various types of hydronic heat distribution systems, the temperature limits of the geothermal system must be a major consideration. In new construction, the distribution system can easily be designed with the temperature limits in mind. In retrofits, care must be taken to address the operating temperature limits of the existing distribution system. The maximum storage tank temperature for the OptiHeat is 150°F (65°C). Typical in floor radiant systems require much lower temperatures, typically 100°-115°F, which is ideal for the OptiHeat.

On load pumps open the screw 2 turns only in the end of the pump motor (if Grundfos® pumps are used) to allow trapped air to be discharged and to ensure the motor housing has been flooded.

Hydronic Section cont.

If using a Geothermal Storage tank there will be two red wires exiting out of the top of the tank. These red wires extend internally down to the thermistor/tank thermostat section of the tank. Remove the bottom tank cover to expose the red wires as well as the yellow tank thermistor wires.

HydroZone

If using HydroZone control under the cover on the Geothermal Storage Tank, connect the two red wires to the two yellow wires using wire nuts. Next, connect the two red wires from the top of the Geothermal Storage tank to "TS" and "GND" on the HydroZone. The "OAT" and "GND" terminals on the HydroZone are used for an outdoor air sensor.

HydroStat

If using HydroStat control under the cover on the Geothermal Storage Tank, connect the two red wires to the yellow wires using wire nuts. Next, connect the two red wires from the top of the Geothermal Storage tank to "TS" and "GND" on the HydroStat. The "OAT" and "GND" terminals on the HydroStat are used to connect the controller to the ELWT (Entering Load Water Temperature) well point sensor. This sensor is located on the load side entering water line inside the unit.

For other field installed controllers, these two red wires will need wired to the appropriate sensor input terminals. Another option for connection is to connect the thermostat on the Geothermal Storage tank directly to "R" and "Y1" on the ABC board.

Adequate rate of flow (GPM) is very important to system performance and long term reliability. Follow the guidelines for recommended flow in the recommendations table.

Leaving load temperature to never exceed 145°F.

Geothermal Storage Tank Thermostat and Thermistor

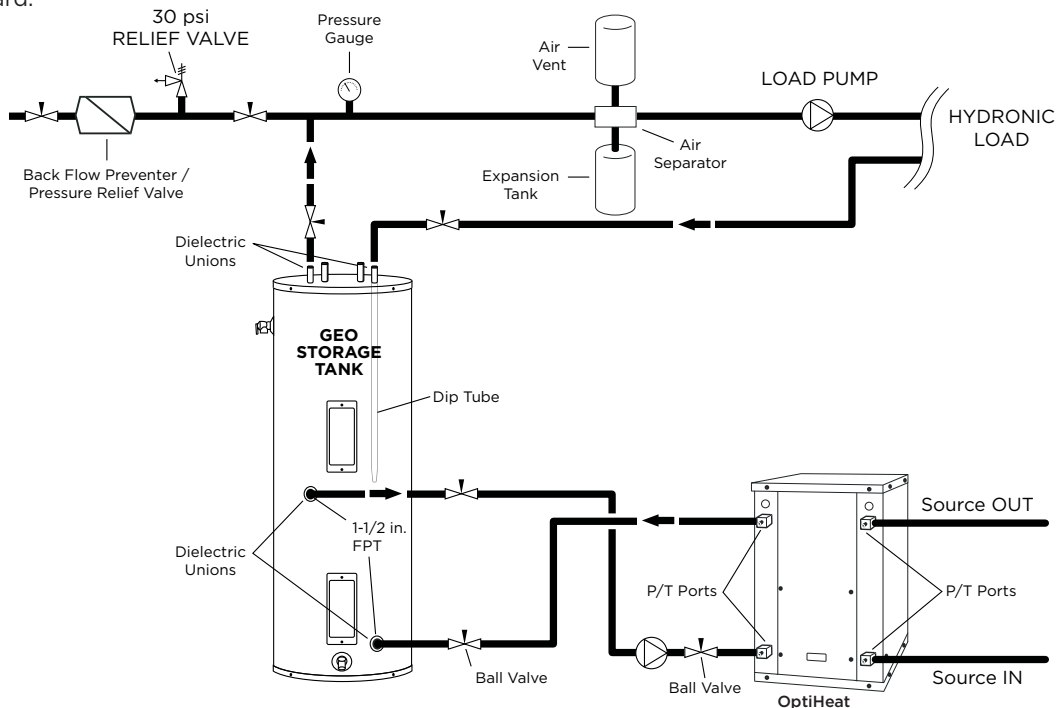
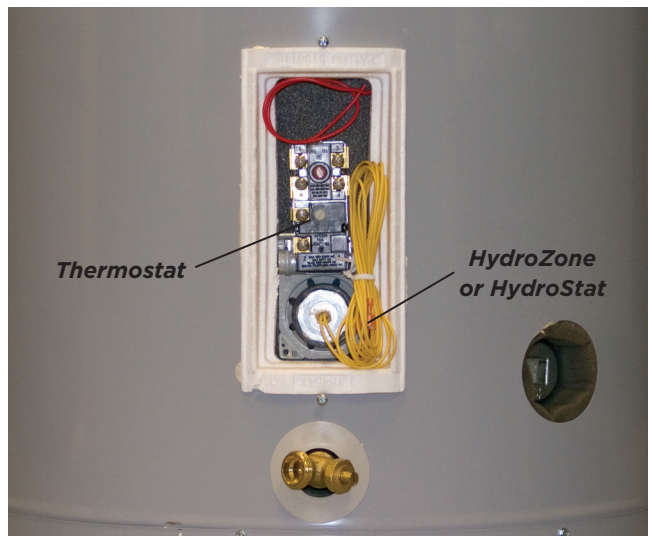

NOTES:

- * A 30 psi pressure relief valve (Part No: SRV30) should be used in hydronic applications.
- ** Vent valve or P/T port at highest point in return line prior to ball valve.

Hydronic Section cont.

Optiheat With Back Up Boiler

SOURCE		LOAD			
MODEL	MINIMUM OPEN LOOP FLOW RATE	MINIMUM CLOSED LOOP FLOW RATE	NORMAL SOURCE RATE	MINIMUM FLOW RATE *	MAXIMUM FLOW RATE *
040	5.0	8.0	10.0	8.0	12.0
050	8.0	12.0	15.0	11.5	18.0
066	10.0	15.0	20.0	15.0	25.0

Optiheat Recommended Storage Tank Sizing

Model	Tank Capacity Gallons/Liters
040	80 G/300 L
050	120 G/450 L
066	120 G/450 L



Recommend using HydroStat to control the Optiheat, set tank temperature and deadband (min 10° F) among other features. The HydroStat set point should be adjusted so that when the set point is reached the Optiheat leaving load temp does not exceed 145° F. The tank sensor will connect to the HydroStat. When the tank temp falls below the set point minus the deadband the circulator pump will be required to pump water through the Optiheat. The sensor will be installed with a temp sensor inside the Optiheat and will determine if the Optiheat operates.

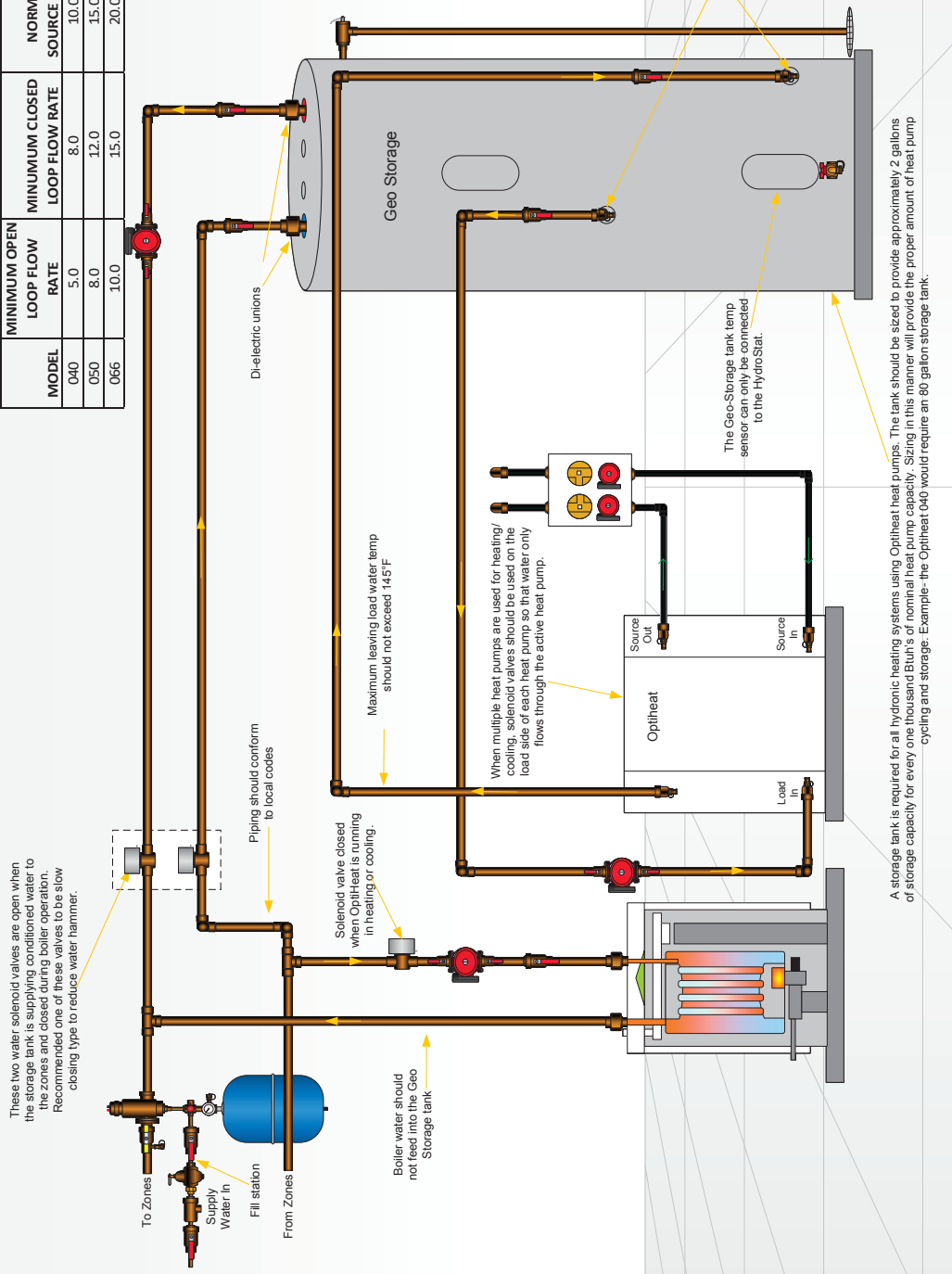

These two water solenoid valves are open when the storage tank is supplying conditioned water to the zones and closed during boiler operation. Recommended one of these valves to be slow closing type to reduce water hammer.

Boiler water should not feed into the Geo Storage tank

A storage tank is required for all hydronic heating systems using Optiheat heat pumps. The tank should be sized to provide approximately 2 gallons of storage capacity for every one thousand Btu's of nominal heat pump capacity. Sizing in this manner will provide the proper amount of heat pump cycling and storage. Example- the Optiheat 040 would require an 80 gallon storage tank.

External Control

An external controller is necessary for operation. For water storage tank set point control the HydroStat HSC, HZC, and HZO were designed specifically for our Geo-Storage Tanks. A field supplied aquastat may also be used as the external control to the heat pump.

HydroStat (HSC) features:

- Communicating Controller
- Pump Sampling
- 2 1/2" x 2 1/2" LCD display and five push buttons serve as the human interface
- Controls and regulates water tank temperature
- Fahrenheit or Celsius
- Symphony Compatibility - without HydroStat the tank temperature won't be displayed on Symphony. (if available)
- Single Stage
- Outdoor Reset

HydroZone (HZC) features:

- 2 1/2" x 2 1/2" LCD display and five push buttons serve as the human interface
- Controls and regulates water tank temperature
- Fahrenheit or Celsius
- Outdoor reset
- Warm weather shutdown
- Single Stage

HydroZone (HZO) features:

- HZC mounted on 7.5" x 7.5" x 3.25" electrical box
- HydroZone relay board
- 2 1/2" x 2 1/2" LCD display and five push buttons serve as the human interface
- Controls and regulates water tank temperature
- Fahrenheit or Celsius
- Outdoor reset
- Warm weather shutdown
- Staging (up to 4 stages)
- Lead/Lag (when staging)

When designing the controls for the heat pump you need to make sure the leaving load temperature (LLT) does not exceed 145°F during operation. Operating the heat pump with a LLT above 145°F results in the compressor running out of envelope and reducing compressor reliability. You may need to increase load water flow or decrease the set point. Increasing the load water flow will lower the discharge pressure and compressor temperature. You also need to make sure that there is adequate run time, so that the compressor is not constantly cycling on and off based on the anti-short cycle timer (4 minutes) and compressor minimum run time (2 minutes). Consistent cycling of the compressor will reduce the reliability of the compressor.

Accessories and Options

IntelliStart

IntelliStart is a single phase compressor soft starter which reduces the normal start current (LRA) by 60-70%. It should be used in applications that require low starting amps, reduced compressor start-up noise, off-grid, and improved start-up behavior. IntelliStart is available as a factory installed option or a field installed kit. IntelliStart is available on 208-230/60/1 voltage.

Water Connection Kits (Field Installed)

Water connection kits are available to facilitate loop side and load side water connections.

- **MA4FPT** - Forged brass 1" MPT x 1" FPT square street elbow with P/T plug for O40 water side connections
- **MA5FPT** - Forged brass 1.25" MPT x 1.25" FPT square street elbow with P/T plug for O50-O66 water side connections
- **WFI-HKM-100-24-MO** - 1 inch x 24 inch stainless steel braided hose kit
- **WFI-HKM-125-24-MO** - 1¼ inch x 24 inch stainless steel braided hose kit

Earth Loop Pump Kit (Field Installed)

A specially designed one or two-pump module provides all liquid flow, fill and connection requirements for independent single unit systems (230/60/1 only). The one-pump module (FC1-FPT or FC1-GL) is capable of 25 feet of head at 12.0 GPM, while the two-pump module (FC2-FPT or FC1-GL) is capable of 50 feet of head at 12.0 GPM.

Load-side Pump Kit (Field Installed)

Four (4) load pump kits are available to provide all liquid flow requirements for independent single unit systems (230/60/1 only). Part number **24S516-10** (Grundfos UPS15-42RU) is a composite body pump. **EWPK2** (Grundfos UP26-99SF) is stainless steel body pump. Part number EWPK1 and EWPK3 come with a cast iron body pump (Grundfos UP26-99F) that can be used for hydronic heating applications.

Calculate the system pressure drop then refer to the pump curves in figure 8 to select the proper pump. All four (4) of the pump kits can be used for hydronic heating applications as long as they meet the flow requirements. If the flow requirements are outside the pump curve, an alternate pump will need to be obtained to maintain the necessary flow.

- **24S516-10** - UPS15-42RU composite PPS, ¾ inch union sweat connection
- **EWPK1** - UP26-99F cast iron volute, 1 inch FPT flange connection
- **EWPK2** - UP26-99SF Stainless Steel volute, 1 inch FPT flange connection
- **EWPK3** - UP26-99F cast iron volute, 1-¼ inch FPT flange connection

Figure 8: UPS15-42RU and UP26-99F Pump Curve

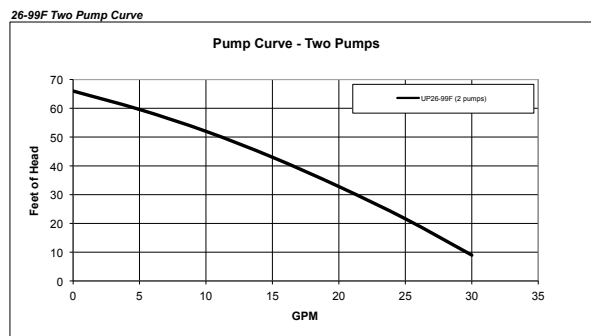
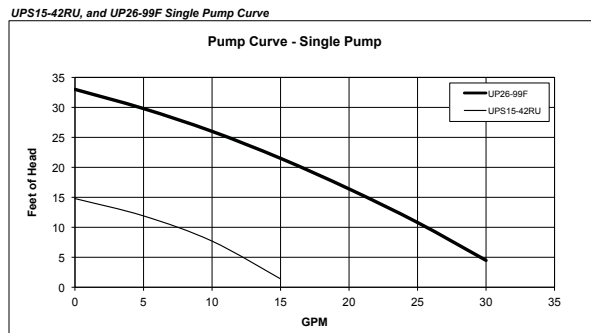

NOTE: Never use piping smaller than 1 inch. Limit length of pipe to 50 feet or less.

Type L Copper Pressure Loss Ft of Hd per 100 ft

GPM	Type L Copper Tube				
	¾	1	1-¼	1-½	2
2	1.5				
3	3.2				
4	5.5	1.4			
5	8.5	2.1			
6		2.9	1.1		
7		3.9	1.4		
8		5.0	1.8		
9		6.1	2.3	0.9	
10		7.5	2.8	1.1	
12			3.9	1.6	
14			5.2	2.1	
16			6.6	2.7	
18			8.2	3.4	
20			10.0	4.1	1.1
22				5.0	1.3
25				6.3	1.6
30					2.2
35					2.9
40					3.8
45					4.7
50					5.7

NOTE: Standard piping practice limits pressure drop to 4 feet of hd per 100 feet in 2 inch and larger pipe.

Accessories and Options cont.

Geo Storage Tank Dimensions

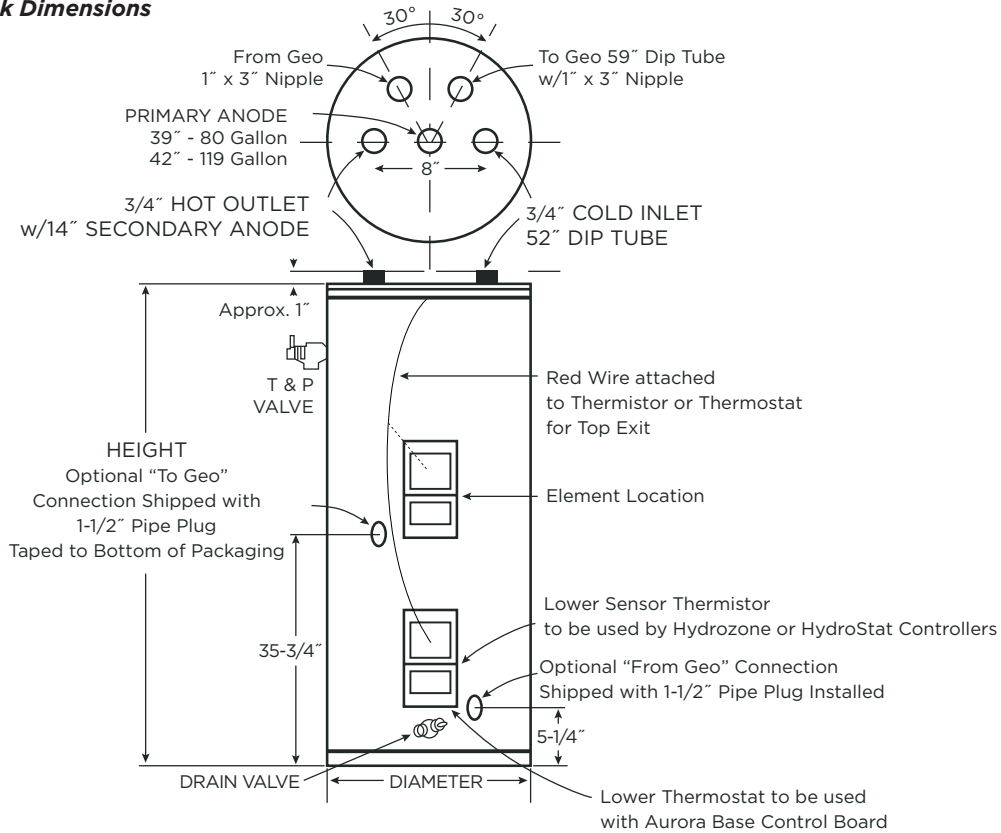

MODEL NUMBER	GALLON CAPACITY	ELEMENT WATTAGE (240 VOLT)	NUMBER OF ELEMENTS	R VALUE	DIMENSIONS IN INCHES		APPROX. SHIPPING WEIGHT (lbs.)
					HEIGHT	DIAMETER	
GEO-STORAGE-80*	80	4500	1	16	63-1/4	24	204
GEO-STORAGE-120**	119	4500	1	16	63-1/4	28	311

* 040 Only

** 050 & 066 Only

NOTE: A buffer tank is required for all hydronic heating systems using OptiHeat heat pumps. The tank should be sized to provide a minimum of 2 gallons of storage capacity for every one thousand Btuh's of nominal heat pump capacity. Sizing in this manner will provide the proper amount of heat pump cycling and storage. The tank must be sized correctly to match the load of the system so that there is adequate compressor run time. An under sized tank will cause the compressor to have a short run time. We do not recommend the use of indirect water heaters for that reason. If the indirect tank is plumbed to the internal water coil there is not enough water volume and depending on the draw of the tank the call for heating may be less than the 2 minute minimum compressor run time, but since the unit will until the 2 minute timer expires the LLT may exceed 145°F. Operating the heat pump with a LLT above 145°F results in the compressor running out of envelope and reducing compressor reliability.

Electrical Data

Model	Rated Voltage	Voltage Min/Max	Compressor				Load Pump	Source Pump	Total Unit FLA	Min Ckt Amp	Maximum Fuse/HACR
			MCC	RLA	LRA	LRA*					
040	208-230/60/1	198/254	27.7	17.8	135.0	47.0	1.8	5.4	25.0	29.5	45
050	208-230/60/1	198/254	37.8	24.2	178.0	62.0	1.8	5.4	31.4	37.5	60
066	208-230/60/1	198/254	40.3	25.8	178.0	62.0	1.8	5.4	33.0	39.5	60

Notes: All fuses type "D" time delay (or HACR circuit breaker in USA).
 Source pump amps shown are for up to a 1/2 HP pump
 Load pump amps shown are for small circulators.
 *LRA with IntelliStart installed

11/21/22

OptiHeat Control Box

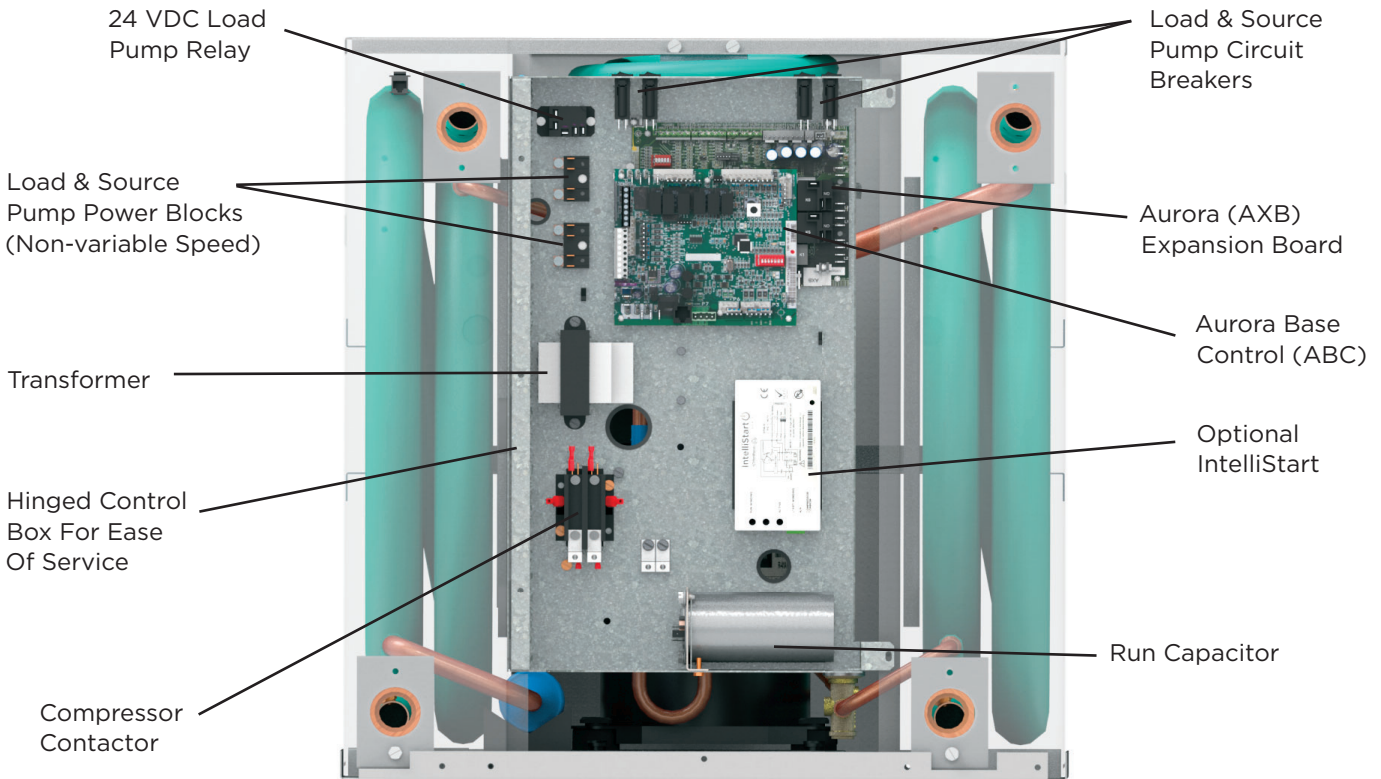

Electrical Data cont.

208 Volt Operation

All 208-230 volt units are factory wired for 230 volt operation. To convert the unit from a 230V unit to a 208V unit follow these steps:

1. Remove the blue transformer wire from terminal L2 on the compressor contactor and secure the wire taking care to insulate the end with electrical tape.
2. Locate the red transformer wire and connect it to the L2 terminal of the compressor contactor.

Electrical

Be sure the available power is the same voltage and phase as that shown on the unit serial plate. Line and low voltage wiring must be done in accordance with local codes or the National Electric Code, whichever is applicable. Refer to the Electrical Data table for wire and fuse or circuit breaker sizing information.

Flow Center Pump Connection (208-230/60/1)

Two circuit breaker protected internal terminal block connections with 1/4-inch spade connectors are provided; one for the load pump and one for the source pump. The source pump directly connects to the PB2 terminal block. The load pump directly connects to the PB1 terminal block. Do not wire variable speed pumps in this manner. See schematics for VS pump wiring.

Control Box Relocation

The control box can be installed on the rear non water line side of the unit. To relocate the control box, follow the procedures below.

1. Remove all power sources to the unit.
2. Remove the unit's top panel.
3. Cut all plastic wire ties to the following:
 - a) High pressure switch (black wires)
 - b) Low pressure switch (blue wires)
 - c) Freeze sensing temperature sensor
 - d) Load temperature sensor
 - e) Compressor wires
4. Remove the five screws from the control box. (3 hinge-side, 2 in opposite corner posts.)
5. Relocate the control box to opposite end of the unit.
6. Using the screws removed in step 4 above, reattach the control box.
7. Secure all wires so they do not come in contact with refrigerant lines.
8. Move the RS485 Keystone coupler to the opening on the back side of the unit.
9. Replace the top of the unit.
10. Replace both access panels.
11. Reapply power sources.

Wiring Schematics

Aurora Advanced EVI Water-Water 208-230/60/1

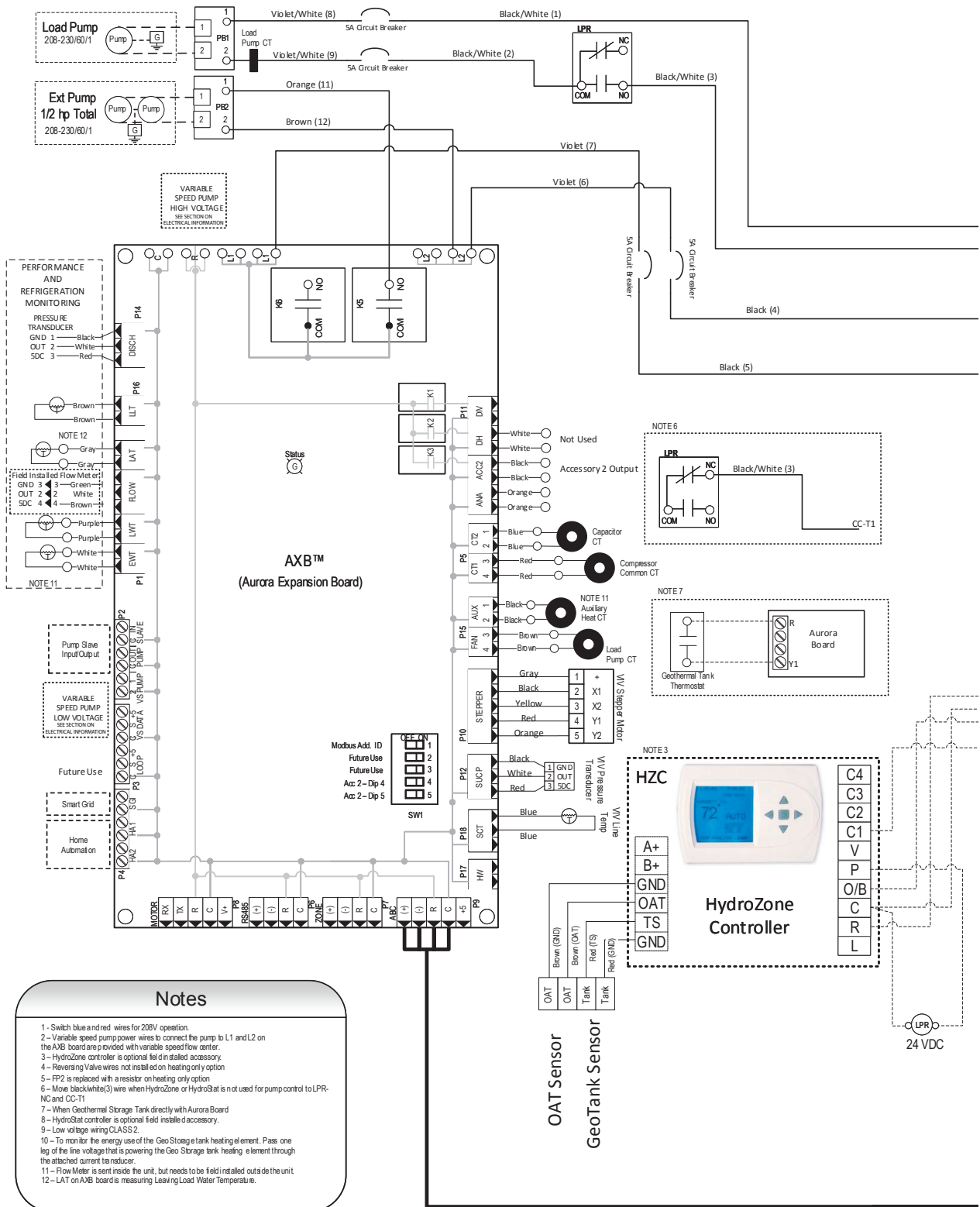

Wiring Schematics cont.

Aurora Advanced EVI Water-Water 208-230/60/1

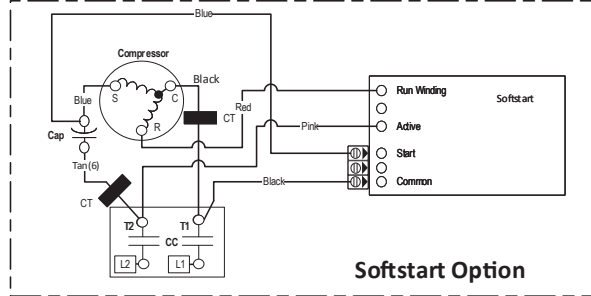
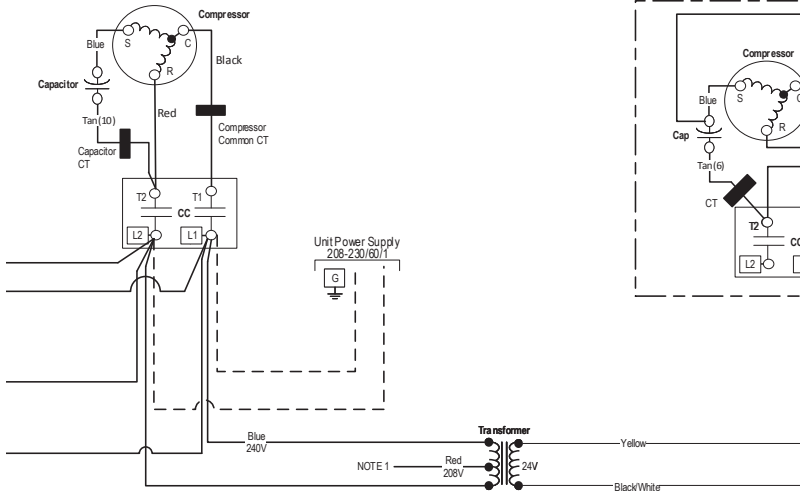

Aurora LED Flash Codes

Slow Flash	1 second on and 1 second off	Configuration LED (LED2, Yellow)	No Software Override	OFF
Fast Flash	100 milliseconds on and 100 milliseconds off	Configuration LED (LED2, Yellow)	DIP Switch Override	Slow Flash
Flash Code	100 milliseconds on and 400 milliseconds off with a 2 second pause before repeating	Configuration LED (LED2, Yellow)		
Random Start Delay (Alerting Colors)		Configuration LED (LED2, Yellow)		
Status LED (LED1, Green)	Fast Flash	Configuration LED (LED2, Yellow)	Fast Flash	
Fault LED (LED3, Red)	Fast Flash	Fault LED (LED3, Red)	Fast Flash	
Fault LED (LED1, Red)		Status LED (LED3, Green)		
Normal Mode	OFF	Normal Mode	ON	
Input Fault Lockout	Flash Code 1	Control is Non-Functional	OFF	
High Pressure Lockout	Flash Code 2	Test Mode	Slow Flash	
Low Pressure Lockout	Flash Code 3	Lockout Active	Fast Flash	
Future Use	Flash Code 4	Dehumidification Mode	Flash Code 2	
Freeze Detection - FP1	Flash Code 5	Future Use	Flash Code 3	
Reserved	Flash Code 6	Future Use	Flash Code 4	
Condensate Overflow Lockout	Flash Code 7	Load Shed	Flash Code 5	
Over/Under Voltage Shutdown	Flash Code 8	ESD	Flash Code 6	
Future Use	Flash Code 9	On Peak Mode	Flash Code 7	
Compressor Monitor	Flash Code 10			
FP1 Sensor Error	Flash Code 11			

ABC SW2 Accessory Relay

DESCRIPTION	SW2-4	SW2-5
Cycle with Blower	ON	ON
Cycle with Compressor	OFF	OFF
Water Valve Slow Opening	ON	OFF
Cycle with Comm. T-stat Hum Cnd	OFF	ON

Aurora Timing Events

Event	Normal Mode	Test Mode
Random Start Delay	5 to 80 seconds	1 second
Compressor On Delay	5 seconds	< 1 second
Compressor Minimum On Time	2 minutes	5 seconds
Compressor Short Cycle Delay	4 minutes	15 seconds
Fault Recognition Delay - High Pressure	Less than 1 second	Less than 1 second
Start-Up Bypass - Low Pressure	2 minutes	30 seconds
Fault Recognition Delay - Low Pressure	30 seconds	30 seconds
Start-Up Bypass - Low Water Coil Limit	2 minutes	30 seconds
Fault Recognition Delay - Low Water Coil Limit	30 seconds	30 seconds
Fault Recognition Delay - Condensate Overflow	30 seconds	30 seconds
HydroZone Call Recognition Time	2 seconds	2 seconds
Water Valve Slow Open Delay	90 seconds	90 seconds

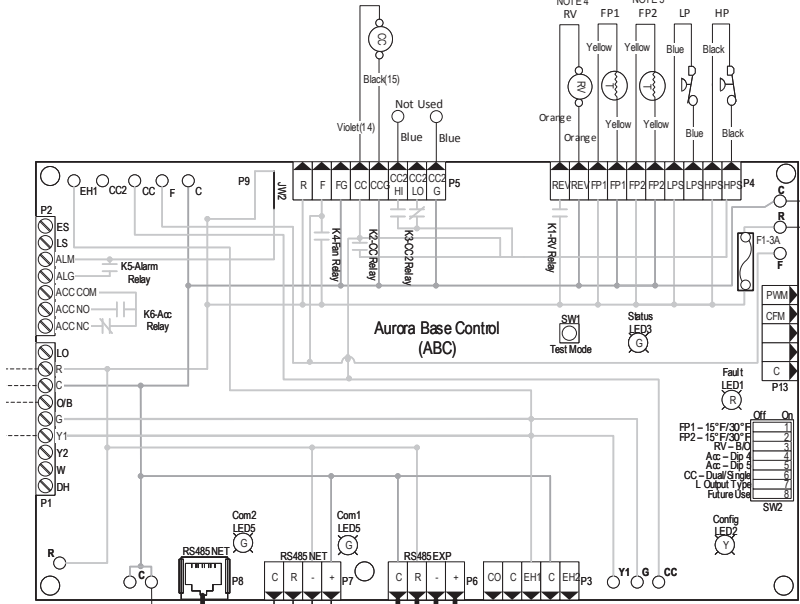

Legend

- Field Installed Item
- Factory Low voltage wiring
- Factory Line voltage wiring
- Field low voltage wiring
- Field line voltage wiring
- Optional block
- DC Voltage PCB traces
- Junction
- Quick connect terminal
- Wire nut
- Field wire lug
- Ground
- Relay Contacts - NO, N.C.
- Fuse
- Blower
- Compressor Contactor
- Condensate overflow sensor
- DHW pump relay
- Loop pump relay
- High pressure switch
- Low pressure switch
- Vapor Injection Valve
- Load Pump Relay
- Thermistor
- Light emitting diode - Green
- Relay coil
- Capacitor w/ bleed resistor
- Switch - Condensate overflow
- Switch - High pressure
- Switch - Low pressure
- Polarized connector
- Compressor Contactor
- Condensate overflow sensor
- DHW pump relay
- Loop pump relay
- High pressure switch
- Low pressure switch
- Vapor Injection Valve
- Load Pump Relay
- Power blocks
- Reversing Valve coil
- DIP package 5 position AXB
- TESTMODE ABC Board
- DIP package 8 position ABC Board
- Freeze Protection
- Outdoor Air Temperature

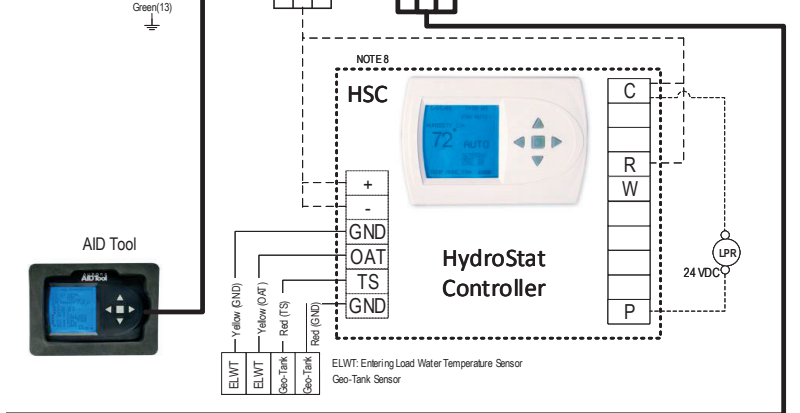

Unit Startup

Before Powering Unit, Check the Following:

NOTE: Remove and discard the compressor hold down shipping bolt located at the front of the compressor mounting bracket.

- **High voltage wiring is correct and matches the nameplate.**
- **Fuses, breakers and wire size are correct.**
- Piping is completed and water system has been cleaned and flushed.
- Air is purged from the closed loop system.
- Isolation valves are open and loop water control valves or loop pumps are wired.
- Service/access panels are in place.

Powering The Controls

Initial Configuration of the Unit

Before operating the unit, apply power and complete the following Aurora Startup procedure for the controls configuration. An AID Tool is recommended for setup, configuration and troubleshooting, especially with an Aurora 'Advanced' Control. AID Tool version 2.18 or greater is preferred.

1. Configure Aurora Screen

- a. In advanced controls - Confirm AXB is added and communicating.
- b. If HydroStat is installed, add 'TST' and ensure communication is present.

2. Aurora Setup Screen

- a. AXB Setup
 - i. Variable Speed Pump Setup and Modulating Water Valve Setup - Can be setup to a range between 5% and 100%. Defaults are 75% and 100%.
 - From the Main Menu of the AID Tool go to AXB Setup and select "Yes" at the bottom of the screen to Make Changes
 - Set VS Pump Control to MIN
 - The pump(s) or water valve should begin to operate and flow rate is visible on this screen, it may take several seconds for flow to stabilize. Adjust the minimum % until the minimum flow rate is achieved.
 - Go back to Set VS Pump Control and select MAX.
 - Adjust maximum % to the same setting as minimum %.
 - Press Enter.
- b. Sensor Kit Setup
 - i. Brine Selection - for HE/HR capacity calculation
 - ii. Flow Meter - activates the flow meter
 - iii. Activate energy option
Load pump and Aux heat current sensor activation
 - iv. Line Voltage calibration - Voltmeter required to calibrate line voltage during heating or cooling. Refer to Line Voltage Calibration in this manual for more details.
- c. Smart Grid Setup - Select Action option for utility received on-peak signal
- d. Home Automation 1 & 2 Setup - Select type of sensor for two home automation inputs.

Unit Startup cont.

Configuring the Sensor Kits

Configuring the Sensor kits

The Aurora Advanced Control allows Refrigeration, Energy, and Performance Monitoring sensor kits. These kits can be factory or field installed. The following description is for field activation of a factory installation of the sensor kits.

Energy Monitoring (Standard Sensor Kit)

The Energy Monitoring Kit includes two current transducers (load pump and electric heat) and two compressor sensors so that the complete power usage of the heat pump can be measured. The AID Tool provides a line voltage calibration procedure to improve accuracy. This information can be displayed on the AID Tool or Symphony via AWL (if available). Ensure the Energy Kit has been enabled by accessing the 'Sensor Kit Setup' in the AID Tool and complete the following:

- a. Activate 'Energy Option' to activate the sensors for compressor (2), load pump and aux heat current.
- b. Select 'Pump' option of FC1, FC2, or open loop. Select 'Open Loop' if this heat pump is linked to a flow center through another heat pump. This selects the pump watts used in the calculation. Source pump watts are not measured but estimated.
- c. Line Voltage Calibration - Voltmeter required to calibrate line voltage during heating or cooling. Refer to Line Voltage Calibration in this manual for more details.
 - i. Turn on Unit in Heating or Cooling .
 - ii. Use multimeter at L1 and L2 to measure line voltage
 - iii. In the Sensor Kit Setup screen adjust the 'Base Voltage' to the nearest value to that is measured
 - iv. Then use the 'Fine Adjust' to select the exact voltage being measured at L1 and L2.
 - v. Exit 'Sensor Setup' Screen
- e. Power Adjustment: Refer to the Power Adjustment tables in the Aurora 'Advanced' Control section of the literature
 - i. On the Main Menu screen select Setup
 - ii. Once in the Setup menu select the Power Adjustment Factor
 - iii. Power Adjustment - allows you to enter the unit's compressor power setting for high and low speed operation. Refer to the tables and use the voltage that is closest to the unit's line voltage and set the power adjustment accordingly.
- f. Energy monitoring can be read on any of the following components:
 - i. AID Tool - instantaneous information only
 - ii. Symphony Web Portal via AWL device connected to Aurora (if available)

Performance and Refrigerant Monitoring (Standard Sensor Kit)

The optional Performance and Refrigeration Monitoring Kits includes a pressure sensor, temperature sensors, and a source side water flow rate sensor. The temperature sensors monitor entering and leaving source, leaving load water, heating liquid line and existing cooling liquid line (FP1). The pressure sensor monitors the system's discharge pressure. With this kit, heat of extraction and rejection will be calculated. This requires configuration using the AID Tool for selection of water or antifreeze. These sensors also allow for the subcooling to be displayed on the AID Tool or Symphony via AWL (if available). **NOTE: Superheat displayed on the AID Tool is not true superheat, it is the superheat of the vapor injection circuit.**

Ensure the Performance and Refrigeration Kit has been enabled by accessing the "Sensor Kit Setup" in the AID Tool and complete the following:

- a. Select "Brine" - and then choose Water or Antifreeze for the proper factor.
- b. Select "Flow Meter" - to activate the flow sensor choose 1 in.
- c. Turn on the Unit in Heating or Cooling.
- d. Use the AID Tool to view the refrigerant performance in the "Refrigerant Monitor" screen.
- e. Use the AID Tool to view the performance in the "Performance Monitor" screen.
- f. Performance and Refrigerant monitoring can be read on any of the following components:
 - i. AID Tool - Instansaneous information only
 - ii. Symphony Web Portal via AWL device connected to Aurora. (If available)

The Aurora ‘Base’ Control System

Aurora ‘Base’ Control

The Aurora ‘Base’ Control (ABC) System is a complete residential and commercial comfort system that brings all aspects of the HVAC system into one cohesive module network. The ABC features microprocessor control and HP, LP, freeze detection, over/under voltage faults.

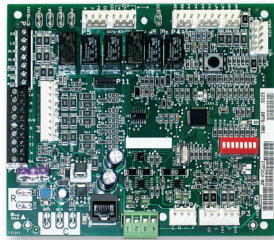

Aurora uses the Modbus communication protocol to communicate between modules. Each module contains the logic to control all features that are connected to the module. The Aurora ‘Base’ Control (ABC) has two Modbus channels for connecting the Aurora Interface Diagnostics Tool (AID Tool).

Aurora ‘Advanced’ Control

The Aurora ‘Advanced’ Control expands on the capability of the Aurora ‘Base’ Control (ABC) System by adding the Aurora Expansion Board (AXB). The additional features include loop pump linking and variable speed pump capability. The AXB also features a second field configurable accessory relay, and two home automation inputs that are AID configurable for different types of alarms from sump pumps to home security. The Smart Grid input is AID configurable with many options to react to Utility controlled relay operation for ON Peak optimization.

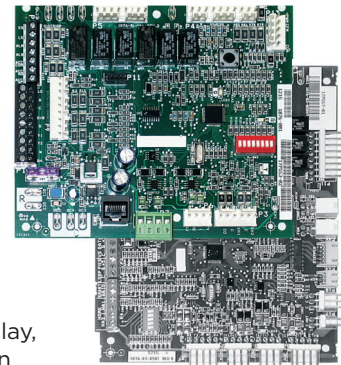

Aurora Control Features	Description	Aurora ‘Advanced’
Microprocessor Compressor Control	Microprocessor control of compressor for timings with FP1, HP, LP, Condensate, assignable Acc relay	•
Advanced Microprocessor Features	Smart Grid, Home Automation Alarm Inputs, and Accessory2 Relay (HRV/ERV)	•
Advanced Speed Pump Control	Microprocessor and separate power relay for loop pump and inline circuit breakers and loop pump linking.	•
Variable Speed Pump	Capable of setup, monitoring and controlling a variable speed flow center.	•
Smart Grid/Utility Input	Allows simple input to externally enable of occupied/unoccupied mode for basic utility time of use programs.	Dry Contact x1
Home Automation Alarm Input	Allows simple input to signal sump, security, or smoke/CO sensor alarms from other home automation or security systems. The two inputs can be field configured to a number of options and logic.	Dry Contactx2

Service Device	Description	Aurora ‘Advanced’
 <p>Aurora Interface and Diagnostics (AID) Tool</p>	<p>Allows setup, monitoring and troubleshooting of any Aurora Control.</p> <p>NOTE: Although the ABC has basic compatibility with all Aurora, new product features may not be available on older AID Tools. To simplify the basic compatibility ensure the version of AID is at least the same or greater than the ABC software version.</p>	<p>For Service (Ver. 2.xx or greater)</p>

The Aurora™ Control System cont.

Add On Control Feature Kits (field or factory installed)	Description	Aurora 'Advanced'
Geo Energy Monitoring Kit	Monitors realtime power consumption of compressor, aux heat and pump. AXB required.	Standard
Performance & Refrigeration Monitoring Kit	Monitors real time refrigerant temperatures, pressures & water temperatures. For subcooling & calculates the heat of extraction/rejection.	Optional Sensor Kit

Add On Thermostats and Zoning	Description	Aurora 'Advanced'
HSC - HydroStat	Communicating tank controller for one hydronic heat pump.	Optional
HZO	Non-communicating tank controller for up to four heat pumps.	Optional
HZC	Non-communicating tank controller for one hydronic heat pump	Optional

The Aurora ‘Base’ Control System cont.

Aurora ‘Base’ Control

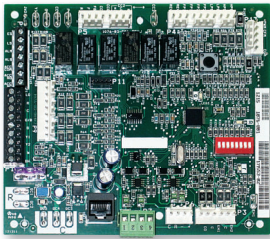

NOTE: Refer to the Aurora Base Control Application and Troubleshooting Guide and the Instruction Guide: Aurora Interface and Diagnostics (AID) Tool for additional information.

Control Features

- Random start at power up
- Anti-short cycle protection
- High and low pressure cutouts
- Loss of charge
- Water coil freeze detection
- Over/under voltage protection
- Load shed
- Emergency shutdown
- Diagnostic LED
- Test mode push button switch
- Alarm output
- Accessory output with N.O. and N.C.
- Two Modbus communication ports

Field Selectable Options via Hardware

DIP Switch (SW1) – Test/Configuration Button (See SW1 Operation Table)

Test Mode

The control is placed in the test mode by holding the push button switch SW1 for 2 - 5 seconds. In test mode most of the control timings will be shortened by a factor of sixteen (16). LED3 (green) will flash at 1 second on and 1 second off. Additionally, when entering test mode LED1 (red) will flash the last lockout one time. Test mode will automatically time out after 30 minutes. Test mode can be exited by pressing and holding the SW1 button for 2 to 5 seconds or by cycling the power. **NOTE:** Test mode will automatically be exited after 30 minutes.

Reset Configuration Mode

The control is placed in reset configuration mode by holding the push button switch SW1 for 50 to 60 seconds. This will reset all configuration settings and the EEPROM back to the factory default settings. LED3 (green) will turn off when entering reset configuration mode. Once LED3 (green) turns off, release SW1 and the control will reset.

DIP Switch (SW2)

SW2-1 (Source) FP1 Selection – Low water coil temperature limit setting for freeze detection. On = 30°F; Off = 15°F.

SW2-2 (Load) FP2 Selection – On = 30°F; Off = 15°F

SW2-3 RV – O/B - thermostat type. Heat pump thermostats with “O” output in cooling or “B” output in Heating can be selected. On = O; Off = B.

SW2-4 Access Relay Operation (P2) and 2-5

Access Relay Operation	SW2-4	SW2-5
Cycle with Blower	ON	ON
Cycle with Compressor	OFF	OFF
Water Valve Slow Opening	ON	OFF
Cycle with Comm. T-stat Hum Cmd	n/a	

Cycle with Blower – Used with water-to-water solenoid valves

Cycle with Compressor – The accessory relay will cycle with the compressor output.

Water Valve Slow Opening – The accessory relay will cycle and delay both the blower and compressor output for 90 seconds.

SW2-6 CC Operation – selection of single or dual capacity compressor. On = Single Stage; Off = Dual Capacity

SW2-7 Lockout and Alarm Outputs (P2) – selection of a continuous or pulsed output for both the LO and ALM Outputs. On = Continuous; Off = Pulsed

SW2-8 *Future Use*

Solenoid Valve

When multiple units are used solenoid valves are to be used on the source and load side of the heat pump. The solenoid valve for the source side is recommended to be wired off of the ABC accessory relay and set to cycle with the fan. Dip switch SW2-4 and SW2-5 both in the ON position.

Alarm Jumper Clip Selection

From the factory, ALM is connected to 24 VAC via JW2. By cutting JW2, ALM becomes a dry contact connected to ALG.

Field Selectable Options via Software

(Selectable via the Aurora AID Tool)

Safety Features

The following safety features are provided to protect the compressor, heat exchangers, wiring and other components from damage caused by operation outside of design conditions.

Fuse – a 3 amp automotive type plug-in fuse provides protection against short circuit or overload conditions.

Anti-Short Cycle Protection – 4 minute anti-short cycle protection for the compressor.

Random Start – 5 to 80 second random start upon power up.

The Aurora 'Base' Control System cont.

Fault Retry - in the fault condition, the control will stage off the outputs and then "try again" to satisfy the thermostat Y input call. Once the thermostat input calls are satisfied, the control will continue on as if no fault occurred. If 3 consecutive faults occur without satisfying the thermostat Y input call, then the control will go to Lockout mode.

Lockout - The Alarm output (ALM) and Lockout output (L) will be turned on. The fault type identification display LED1 (Red) shall flash the fault code. To reset lockout conditions with SW2-8 On, thermostat inputs "Y1", "Y2", and "W" must be removed for at least 3 seconds. To reset lockout conditions with SW2-8 Off, thermostat inputs "Y1", "Y2", "W", and "DH" must be removed for at least 3 seconds. Lockout may also be reset by turning power off for at least 30 seconds or by enabling the emergency shutdown input for at least 3 seconds.

High Pressure - fault is recognized when the Normally Closed High Pressure Switch, P4-9/10 opens, no matter how momentarily. The High Pressure Switch is electrically in series with the Compressor Contactor and serves as a hard-wired limit switch if an overpressure condition should occur.

Low Pressure - fault is recognized when the Normally Closed Low Pressure Switch, P4-7/8 is continuously open for 30 seconds. Closure of the LPS any time during the 30 second recognition time restarts the 30 second continuous open requirement. A continuously open LPS shall not be recognized during the 2 minute startup bypass time.

Loss of Charge - fault is recognized when the Normally Closed Low Pressure Switch, P4-7/8 is open prior to the compressor starting.

Freeze Detection (Source Coax) - set points shall be either 30°F or 15°F. When the thermistor temperature drops below the selected set point, the control shall begin counting down the 30 seconds delay. If the thermistor value rises above the selected set point, then the count should reset. The resistance value must remain below the selected set point for the entire length of the appropriate delay to be recognized as a fault. This fault will be ignored for the initial 2 minutes of the compressor run time.

Freeze Detection (Load Coax) - uses the FP2 input to protect against ice formation on the coax. The FP2 input will operate exactly like FP1.

Over/Under Voltage Shutdown - An over/under voltage condition exists when the control voltage is outside the range of 18 VAC to 30 VAC. If the over/under voltage shutdown lasts for 15 minutes, the lockout and alarm relay will be energized. Over/under voltage shutdown is self-resetting in that if the voltage comes back within range of 18 VAC to 30 VAC for at least 0.5 seconds, then normal operation is restored.

Operation Description

Power Up - The unit will not operate until all the inputs and safety controls are checked for normal conditions. The unit has a 5 to 80 second random start delay at power up. Then the compressor has a 4 minute anti-short cycle delay after the random start delay.

Standby In standby mode, Y1, Y2, W, DH, and G are not active. Input O may be active. The blower and compressor will be off.

Heating Operation

Heating, 1st Stage (Y1) - The compressor is energized 10 seconds after the Y1 input is received.

Cooling Operation

In all cooling operations, the reversing valve directly tracks the O input. Thus, anytime the O input is present, the reversing valve will be energized.

Cooling, 1st Stage (Y1, O) - The compressor is energized 10 seconds after the Y1 input is received.

Emergency Shutdown - Four (4) seconds after a valid ES input, P2-7 is present, all control outputs will be turned off and remain off until the emergency shutdown input is no longer present. The first time that the compressor is started after the control exits the emergency shutdown mode, there will be an anti-short cycle delay followed by a random start delay. Input must be tied to common to activate.

Load Shed - The LS input disables all outputs from the ABC control board. When the LS input has been cleared, the anti-short cycle timer and random start timer will be initiated. Input must be tied to common to activate.

The Aurora ‘Base’ Control System cont.

Aurora ‘Base’ Control LED Displays

These three LEDs display the status, configuration, and fault codes for the control. These can also be read in plain English via the Aurora AID Tool.

Status LED (LED3, Green)

Description of Operation	Fault LED, Green
Normal Mode	ON
Control is Non-functional	OFF
Test Mode	Slow Flash
Lockout Active	Fast Flash
Dehumidification Mode	Flash Code 2
(Future Use)	Flash Code 3
(Future Use)	Flash Code 4
Load Shed	Flash Code 5
Emergency Shut Down	Flash Code 6
On Peak Mode	Flash Code 7

Aurora Interface and Diagnostics (AID) Tool

The Aurora Interface and Diagnostics (AID) Tool is a device that is a member of the Aurora network. The AID Tool is used to troubleshoot equipment which uses the Aurora control via Modbus RTU communication. The AID Tool provides diagnostics, fault management, ECM setup, and system configuration capabilities to the Aurora family of controls. An AID Tool is recommended, although not required. The AID Tool simply plugs into the exterior of the cabinet in the AID Tool port.



ABC Control Board Layout

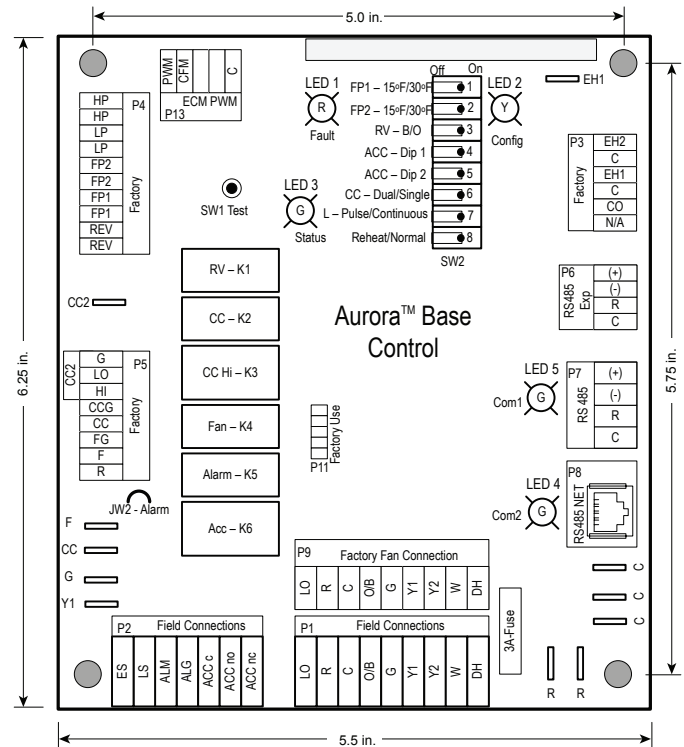

The Aurora ‘Base’ Control System cont.

Aurora ‘Advanced’ Control Features

The Aurora ‘Advanced’ Control system expands on the capability of the Aurora ‘Base’ Control (ABC) by adding the Aurora Expansion Board (AXB). All of the preceding features of the Aurora ‘Base’ Control are included. The following control description is of the additional features and capability of the Aurora advanced control.

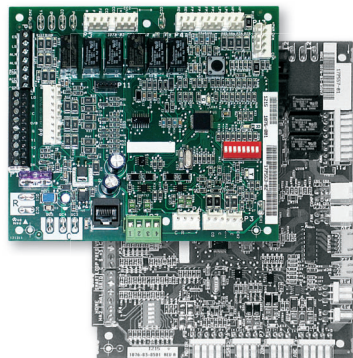

It is highly recommended the installing/servicing contractor obtain an Aurora Interface and Diagnostic Tool (AID) and specialized training before attempting to install or service an Aurora ‘Advanced’ control system.



The additional AXB features include the following:

AXB DIP Switch

DIP 1 - ID: This is the AXB ModBus ID and should always read On.

DIP 2 & 3 - Future Use

DIP 4 & 5 - Accessory Relay2: A second, DIP configurable, accessory relay is provided that can be cycled with the compressor 1 or 2, blower, or the Dehumidifier (DH) input. This is to complement the Accessory 1 Relay on the ABC board.

Position	DIP 4	DIP 5	Description
1	ON	ON	Cycles with Fan or ECM (or G)
2	OFF	ON	Cycles with CC1 first stage of compressor or compressor spd 1-12
3	ON	OFF	Cycles with CC2 second stage of compressor or compressor spd 7-12
4	OFF	OFF	Cycles with DH input from ABC board

Variable Speed Pump

This input and output are provided to drive and monitor a variable speed pump. The VS pump output is a PWM signal to drive the variable speed pump. The minimum and maximum level are set using the AID Tool. 75% and 100% are the default settings respectively. The VS data input allows a separate PWM signal to return from the pump giving fault and performance information. Fault received from the variable speed pump will be displayed as E16. With single speed equipment both min & max should be set to the same value.

Modulating Water Valve

This output is provided to drive a modulating water valve. Through advanced design the 0-10VDC valve can be driven directly from the VS pump output. The minimum and maximum level are set in the same way as the VS pump using the AID Tool. 75% and 100% are the default settings respectively. With single speed equipment both min & max should be set to the same value.

Solenoid Valve

When multiple units are used solenoid valves are to be used on the source and load side of the heat pump. The solenoid valve for the load side is recommended to be wired off of the AXB accessory relay and set to cycle with the fan. Dip switch SW2-4 and SW2-5 both in the ON position.

Compressor Monitoring

The AXB includes two current transducers to monitor the compressor current and starting characteristics. Open circuits or welded contactor faults will be detected. A fault will produce an E10 code.

If the E10 fault code is due to the thermal overload on the compressor being tripped. Ensure adequate water flow on both the load and source side of the unit and review the unit operating envelope. If the unit is operating in the “Sensitive Operating Range”, as shown in the OptiHeat Installation Manual, you may need to adjust the leaving load temperatures.

Loop Pump Linking

This input and output are provided so that two units can be linked together with a common flow center. When either unit has a call for loop pump, both unit’s loop pump relays and variable speed pumps are energized. The flow center then can simply be wired to either unit. The output from one unit should be routed to the input of the other. If daisy chained up to 16 heat pumps can be wired and linked together in this fashion.

Advanced Communication Ports

Communication ports P6 and P8 will provide future expansion via dedicated protocols. These are for future use.

The Aurora ‘Base’ Control System cont.

Smart Grid-On Peak (SG) Input

The ‘On Peak’ input was designed to allow utilities to utilize simple radio controlled switches to control the On Electric Peak behavior of the 5 and 7 Series Geothermal Heat Pumps. With a closed contact signal, this input will limit the operation and thus the power consumption of the unit by one of the below selections. The AID Tool will allow configuration of this input for the action of:

- No Action
- Disable compressor operation until removed
- Go to On Peak thermostat settings until removed [Requires Com T-Stat] (Future Release)
- Compressor limited to 50% or low cap until removed [dual capacity or variable speed only] (Future Release)
- Disable compressor operation for 1/2 hr (can be removed immediately) (Future Release)

Then Flash Code 7 on the Green LED for the ‘On Peak’ mode. And On Peak will display on communicating thermostats.

Home Automation 1 and 2 Inputs

The Home automation inputs are simple closed contact inputs that will trigger an AID Tool and thermostat alert for the homeowner. These would require optional sensors and or equipment for connection to the AXB board. With two inputs two different sensors can be selected. The selected text will then be displayed on the AID Tool and communicating thermostats. These events will NOT alter functionality or operation of the heat pump/accessories and is for homeowner/service notification only.

Home Automation 1 - E23 HA1

With a closed dry contact signal, this input will cause an alarm and Alert Code 23 to indicate on the stat or flash on ABC. The AID Tool will allow configuration of this input between the following selections:

- No Action
- Home Automation Fault [no lockout info only]
 - Output from home automation system
- Security Alarm [no lockout info only]
 - Output from home security
- Sump Alarm Fault [no lockout info only]
 - Switch output from sump sensor
- Smoke/CO Alarm Fault [no lockout info only]
 - Switch output from Smoke/CO sensor
- Dirty Filter Alarm [no lockout info only]
 - Output from dirty filter sensor

Home Automation 2 - E24 HA2

With a closed dry contact signal, this input will cause an alarm and Alert Code 24 to indicate on the stat or flash on ABC. The AID Tool will allow configuration of this input between the following selections:

- No Action
- Home Automation Fault [no lockout info only]
 - Output from home automation system
- Security Alarm [no lockout info only]
 - Output from home security
- Sump Alarm Fault [no lockout info only]
 - Switch output from sump sensor
- Smoke/CO Alarm Fault [no lockout info only]
 - Switch output from Smoke/CO sensor
- Dirty Filter Alarm [no lockout info only]
 - Output from dirty filter sensor

Monitoring Sensor Kits

Energy monitoring (Standard Sensor Kit)

The Energy Monitoring Kit includes two current transducers (load pump and electric heat) added to the existing two compressor sensors so that the complete power usage of the heat pump can be measured. The AID Tool provides a line voltage calibration procedure to improve the accuracy, and a power adjustment setting that allows the compressor power to be adjusted to match the units line voltage using the provided tables. This information can be displayed on the AID Tool.

Performance and Refrigeration Monitoring (Standard Sensor Kit)

The Performance and Refrigeration Monitoring Kits includes a pressure sensor, temperature sensors, and a source side water flow rate sensor. The temperature sensors monitor entering and leaving source, leaving load water, heating liquid line and existing cooling liquid line (FPI). The pressure sensor monitors the system’s discharge pressure. With this kit, heat of extraction and rejection will be calculated. This requires configuration using the AID Tool for selection of water or antifreeze. These sensors also allow for the subcooling to be displayed on the AID Tool. **NOTE: Superheat displayed on the AID Tool is not true superheat, it is the superheat of the vapor injection circuit.**

Power Adjustment Table

Model	Voltage		
	208V	230V	250V
040	.96	.89	.77
050	.96	.89	.77
066	.96	.89	.77

The Aurora™ Control System cont..

Aurora ‘Advanced’ Control LED Displays

These three LEDs display the status, configuration, and fault codes for the control. These can also be read in plain English via the Aurora AID Tool.

Status LED (LED3, Green)

Description of Operation	Fault LED, Green
Normal Mode	ON
Control is Non-functional	OFF
Test Mode	Slow Flash
Lockout Active	Fast Flash
Dehumidification Mode	Flash Code 2
Load Shed	Flash Code 5
Emergency Shutdown	Flash Code 6
On Peak Mode	Flash Code 7
(Future Use)	Flash Code 8
(Future Use)	Flach Code 9

Fault LED (LED1, Red)

Red Fault LED	LED Flash Code *	Lockout	Reset/Remove	Fault Condition Summary	
Normal - No Faults	Off	-			
ABC Basic Faults	Fault-Input	1	No	Auto	Tstat input error. Autoreset upon condition removal.
	Fault-High Pressure	2	Yes	Hard or Soft	HP switch has tripped (>650 psi)
	Fault-Low Pressure	3	Yes	Hard or Soft	Low Pressure Switch has tripped (<40 psi for 30 continuous sec.)
	Fault-Freeze Detection FP2	4	Yes	Hard or Soft	Freeze protection sensor has tripped (<15 or 30 degF for 30 continuous sec.)
	Fault-Freeze Detection FP1	5	Yes	Hard or Soft	Freeze protection sensor has tripped (<15 or 30 degF for 30 continuous sec.)
	Fault-Condensate Overflow	7	Yes	Hard or Soft	Condensate switch has shown continuity for 30 continuous sec.
	Fault-Over/Under Voltage	8	No	Auto	Instantaneous voltage is out of range. **Controls shut down until resolved.
	Fault-FP1 Snsr Error	11	Yes	Hard or Soft	If FP1 Sensor Error
ABC & AXB Advanced Faults	Fault-Compressor Monitor	10	Yes	Hard or Soft	Open Crkt, Run, Start or welded cont, Comp operation in sensitive operating range
	Non-CriticAXBSnsrErr	13	No	Auto	Any Other Sensor Error
	CriticAXBSnsrErr	14	Yes	Hard or Soft	Sensor Error for EEV or HW
	Alert-HotWtr	15	No	Auto	HW over limit or logic lockout. HW pump deactivated.
	Fault-VarSpdPump	16	No	Auto	Alert is read from PWM feedback.
	Not Used	17	No	Auto	IZ2 Com Fault. Autoreset upon condition removal.
	Non-CritComErr	18	No	Auto	Any non-critical com error
	Fault-CritComErr	19	No	Auto	Any critical com error. Auto reset upon condition removal
	Alarm - Low Loop Pressure	21	No	Auto	Loop pressure is below 3 psi for more than 3 minutes
	Alarm - Home Automation 1	23	No	Auto	Closed contact input is present on Dig 2 input - Text is configurable
Alarm - Home Automation 2	24	No	Auto	Closed contact input is present on Dig 3 input - Text is configurable	

NOTES:

*All codes >11 use long flash for tens digit and short flash for the ones digit. 20, 30, 40, 50 etc. are skipped!

Alert' is a noncritical sensor or function that has failed. Normal operation of the heat pump is maintained but service is desired at some point.

Reference Calculations

<p>Heating Calculations:</p> $LWT = EWT - \frac{HE}{GPM \times C^*}$ $HE = C^* \times GPM \times (EWT - LWT)$	<p>Cooling Calculations:</p> $LWT = EWT + \frac{HR}{GPM \times C^*}$ $HR = C^* \times GPM \times (LWT - EWT)$
--	--

NOTE: * C = 500 for pure water, 485 for brine.

Legend and Notes

Abbreviations and Definitions

ELT = entering load fluid temperature to heat pump	kW = kilowatts
SWPD = source coax water pressure drop	EST = entering source fluid temperature to heat pump
LLT = leaving load fluid temperature from heat pump	HE = heat extracted in MBTUH
PSI = pressure drop in pounds per square inch	LST = leaving source fluid temperature from heat pump
LGPM = load flow in gallons per minute	HC = total heating capacity in MBTUH
FT HD = pressure drop in feet of head	COP = coefficient of performance, heating [HC/kW x 3.413]
LWPD = load coax water pressure drop	EER = energy efficiency ratio, cooling
LWT = leaving water temperature	TC = total cooling capacity in MBTUH
EWT = entering water temperature	HR = heat rejected in MBTUH
Brine = water with a freeze inhibiting solution	

Notes to Performance Data Tables

The following notes apply to all performance data tables:

- Three flow rates are shown for each unit. The lowest flow rate shown is used for geothermal open loop/well water systems with a minimum of 50°F EST. The middle flow rate shown is the minimum geothermal closed loop flow rate. The highest flow rate shown is optimum for geothermal closed loop systems and the suggested flow rate for boiler/tower applications.
- Entering water temperatures below 40°F assumes 15% antifreeze solution.
- Interpolation between ELT, EST, and GPM data is permissible.
- Operation in the gray areas is not recommended.

Water Pressure Drop

Model 040

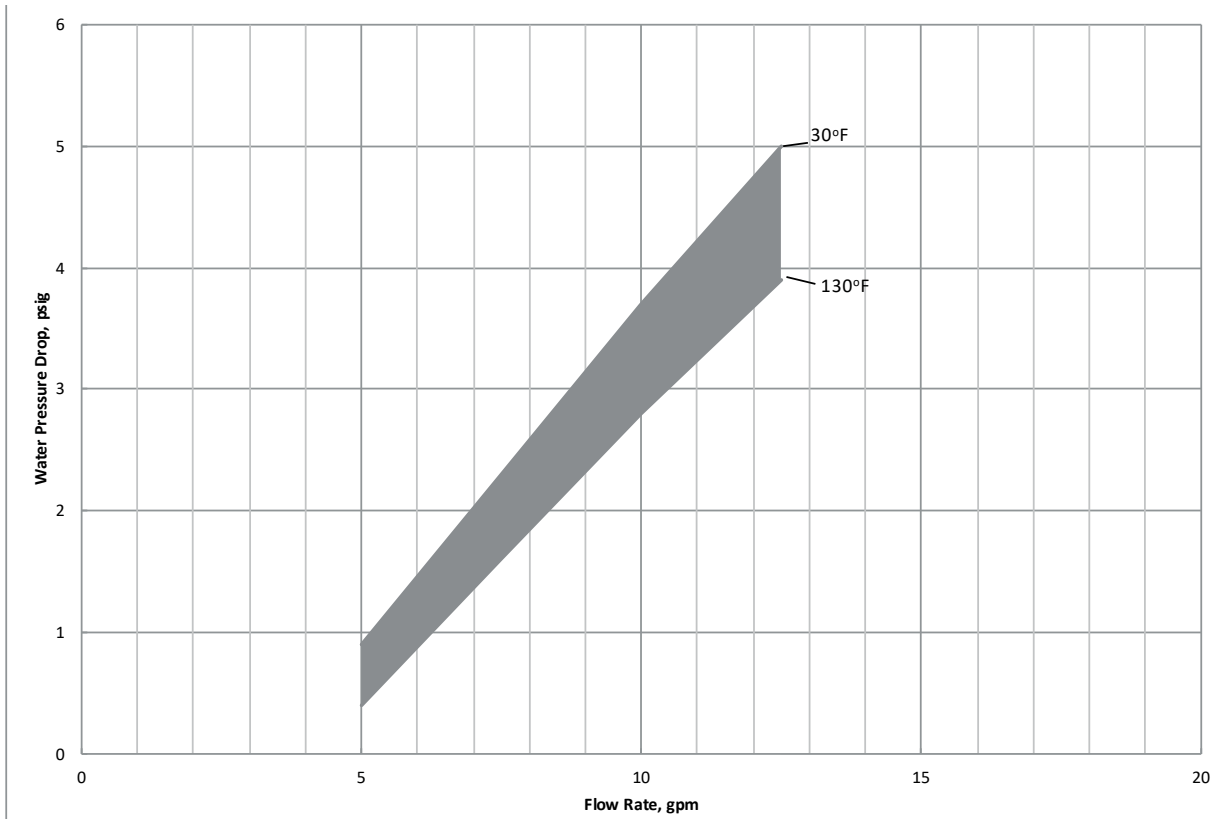

Model 050

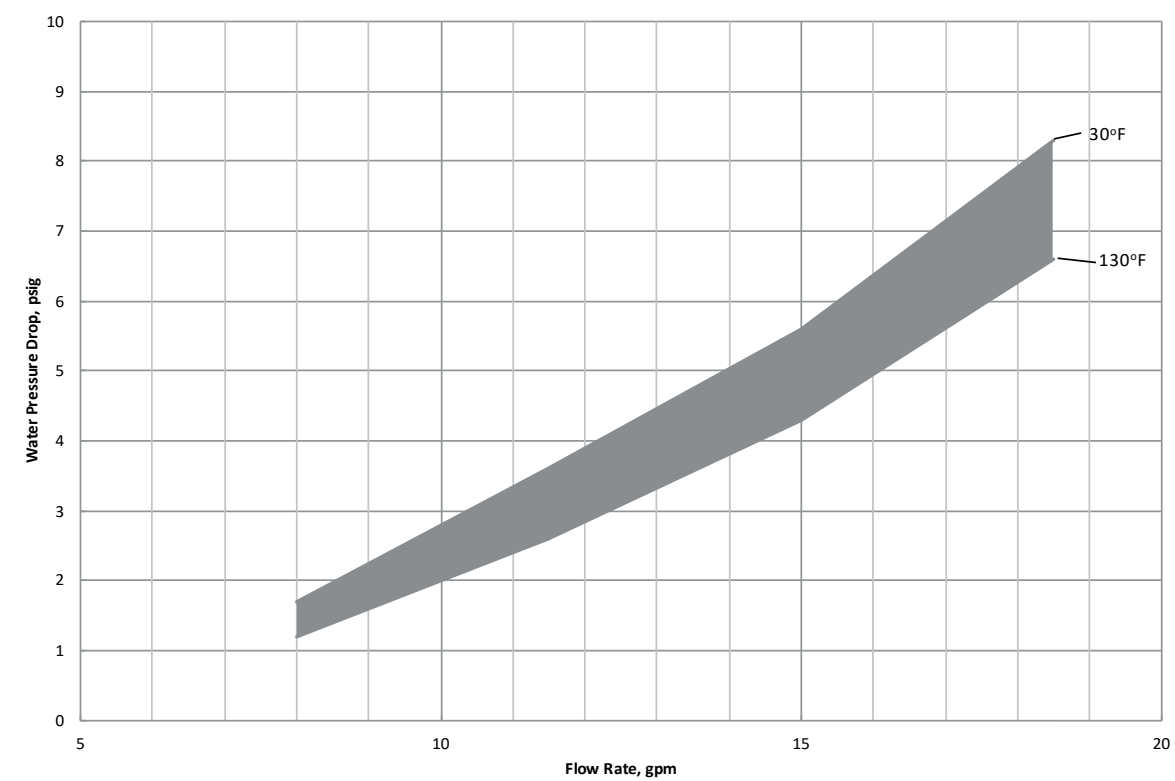

Water Pressure Drop cont.

Model 066

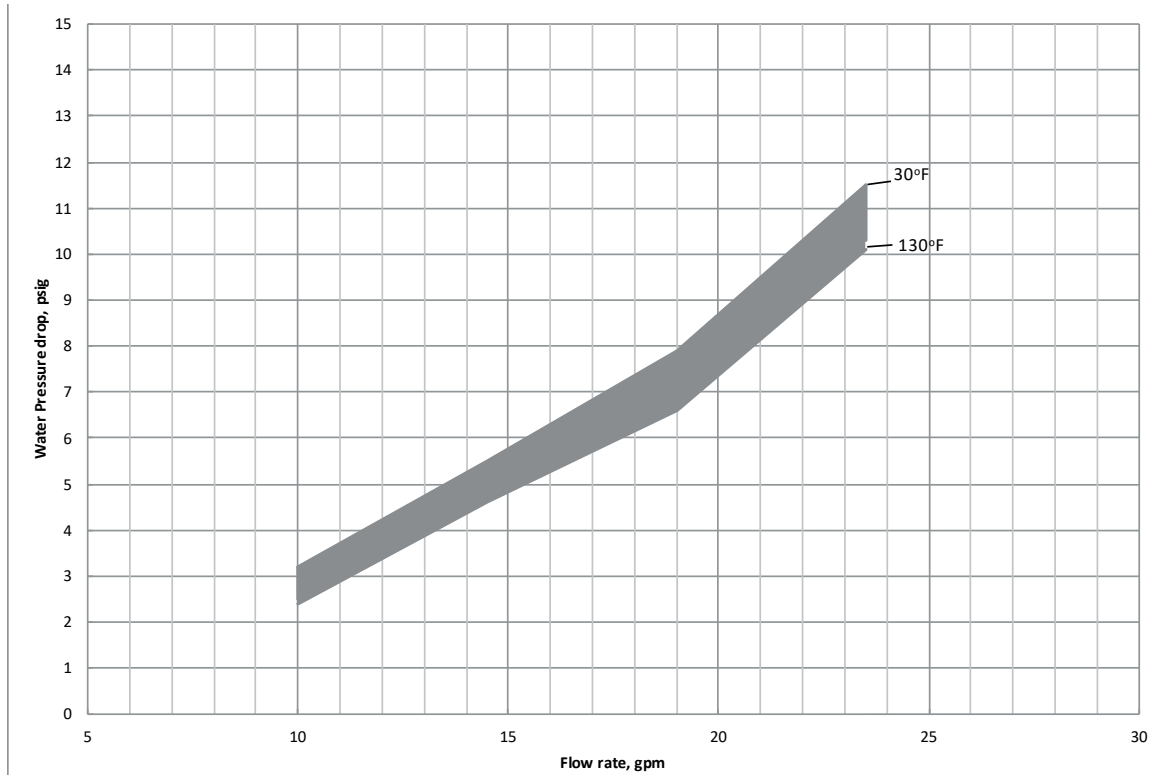

Pressure Drop

Model	GPM	Pressure Drop (psi)						
		30°F	50°F	70°F	90°F	110°F	130°F	150°F
040	5.0	0.9	0.6	0.6	0.5	0.5	0.4	0.3
	7.5	2.3	2.1	2.0	1.9	1.8	1.6	1.5
	10.0	3.7	3.5	3.3	3.2	3.0	2.8	2.7
	12.5	5.0	4.7	4.4	4.2	4.1	3.9	3.7
050	8.0	1.7	1.4	1.4	1.3	1.3	1.2	1.1
	11.5	3.6	3.4	3.2	3.0	2.8	2.6	2.5
	15.0	5.6	5.4	5.0	4.6	4.4	4.3	4.1
	18.5	8.3	8.1	7.6	7.2	6.8	6.6	6.4
066	10.0	3.2	3.0	2.8	2.7	2.5	2.4	2.3
	14.5	5.5	5.3	5.1	4.9	4.7	4.6	4.5
	19.0	7.9	7.6	7.3	7.1	6.8	6.6	6.5
	23.5	11.5	11.3	11.0	10.8	10.3	10.1	9.9

7/8/14

Operating Limits

Operating Limits	Cooling		Heating	
	°F	°C	°F	°C
Source Side Water Limits				
Minimum Entering Water	30	-1.1	20	-6.7
Normal Entering Water	85	29.4	60	15.6
Maximum Entering Water	110	43.3	90	32.2
Load Side Water Limits				
Minimum Entering Water	50	10.0	60	15.6
Normal Entering Water	60	15.6	100	37.8
Maximum Entering Water	90	32.2	140	60

NOTES: Minimum/maximum limits are only for start-up conditions, and are meant for bringing the space up to occupancy temperature. Units are not designed to operate at the minimum/maximum conditions on a regular basis. The operating limits are dependant upon three primary factors: 1) entering source temperature, 2) entering load temperature, and 3) flow rate (gpm). When any of the factors are at the minimum or maximum levels, the other two factors must be at the normal level for proper and reliable unit operation. Consult the Capacity Tables for each model to determine allowable normal operating conditions. Units are not designed for outdoor installation.

Physical Data

Model	040	050	066
Compressor (1 each)	Scroll		
Factory Charge R410A, oz [kg]	94 [2.66]	108 [3.06]	142 [4.02]
Coax & Piping Water Volume - gal [l]	1.0 [3.94]	1.4 [5.25]	1.6 [6.13]
Weight - Operating, lb [kg]	313 [142.0]	348 [157.9]	368 [166.9]
Weight - Packaged, lb [kg]	328 [148.8]	363 [164.7]	383 [173.7]

6/13/19

Flow Rates

MODEL	SOURCE			LOAD	
	MINIMUM OPEN LOOP FLOW RATE	MINIMUM CLOSED LOOP FLOW RATE	NORMAL SOURCE RATE	MINIMUM FLOW RATE *	MAXIMUM FLOW RATE *
040	5.0	8.0	10.0	8.0	12.0
050	8.0	12.0	15.0	11.5	18.0
066	10.0	15.0	20.0	15.0	25.0

Load water flow is to be adjusted so that the maximum Leaving Load Temperature is below 145°F. Operating the heat pump above 145°F will result in the compressor running out of envelope and reducing compressor reliability. You may need to increase load water flow or decrease the set point. Increasing the load water flow will lower the discharge pressure and compressor temperature.

3/29/23

Load flow may have to be adjusted based on source temperature variations.

Heating Operating Envelope

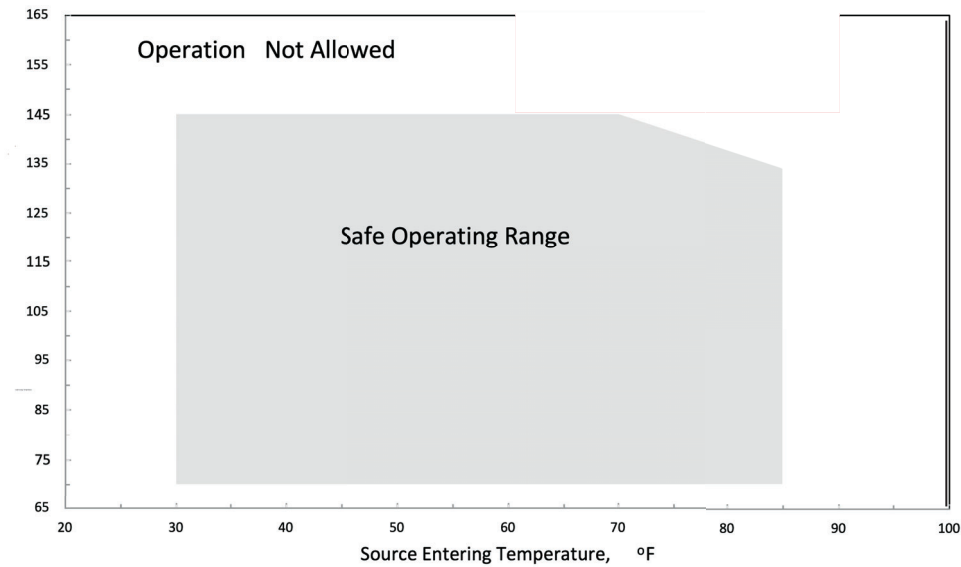

If you are experiencing E10 faults caused by the thermal limit in the compressor being tripped you may need to increase load water flow or decrease the set point. Increasing the load water flow will lower the discharge pressure and compressor temperature. Leaving load temperatures higher than 140F are outside the safe operation of the compressor.

Cooling Operating Envelope

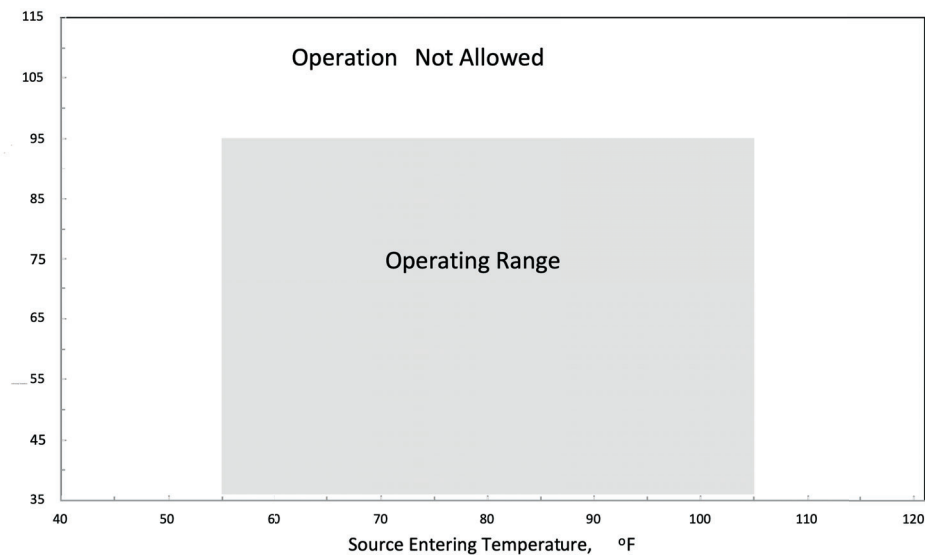

Thermistor and Compressor Resistance

Thermistor Resistance

Thermistor Temperature (°F)	Microprocessor Resistance (Ohms)
5	75757-70117
14	57392-53234
23	43865-40771
32	33809-31487
41	26269-24513
50	20570-19230
59	16226-15196
68	12889-12093
77	10310-9688
86	8300-7812
95	6723-6337
104	5480-5172
113	4490-4246
122	3700-3504
131	3067-2907
140	2554-2424
149	2149-2019

7/8/14

Compressor Resistance Chart

Model	208-230/60/1	
	Run	Start
040	0.46	0.85
050	0.36	0.97
066	0.36	0.97

Note: Table values have a +/- 7% tolerance

7/8/14

Operating Parameters

Heating Mode

Entering Load Temp (°F)	Entering Source Temp (°F)	Suction Pressure (psig)	Discharge Pressure (psig)	Superheat (°F)	Subcooling (°F)	Total Subcooling (°F)
60	30	67-82	208-235	7-14	6-14	20-30
	50	95-113	216-245	7-14	6-12	15-25
	70	124-144	225-255	8-19	5-15	6-16
	90	143-167	230-275	14-26	8-12	8-12
80	30	69-84	293-323	10-12	7-18	7-18
	50	98-125	302-335	12-14	8-16	25-35
	70	121-148	311-346	14-18	8-16	15-25
	90	150-179	319-363	14-26	8-16	8-16
100	30	77-85	378-411	10-12	7-15	45-55
	50	100-126	388-425	12-14	7-15	30-45
	70	133-152	398-438	14-18	3-12	25-35
	90	170-191	408-452	14-22	3-12	14-25
120	30	74-87	464-500	6-16	5-17	55-65
	50	106-128	474-515	5-17	5-15	40-50
	70	135-156	485-530	6-16	4-15	30-40
	90	180-195	500-545	8-14	3-9	20-30
130	30	74-87	520-560	6-16	5-17	55-65
	50	106-128	540-590	5-17	5-15	40-50
	70	140-160	550-600	6-16	3-9	30-40
	90	185-200	560-615	8-14	2-8	20-30

7/8/2014

Operating Parameters cont.

Cooling Mode

Entering Load Temp (°F)	Entering Source Temp (°F)	Suction Pressure (psig)	Discharge Pressure (psig)	Superheat (°F)	Subcooling (°F)
50	30	86-99	135-160	12-22	2-15
	50	92-107	191-214	10-19	4-15
	70	98-115	248-268	5-15	6-16
	90	101-119	335-367	6-15	8-16
	110	105-122	425-465	8-16	10-19
70	30	89-106	131-163	15-20	3-6
	50	103-125	194-223	11-15	6-9
	70	118-143	257-273	11-15	9-12
	90	125-151	344-381	8-12	12-14
	110	135-155	280-315	8-16	10-19
90	30	92-113	128-166	15-20	3-6
	50	115-143	197-233	11-15	6-9
	70	129-158	266-294	11-15	9-12
	90	145-165	350-390	20-30	8-19
	110	160-180	360-400	25-35	7-16
110	30	96-121	125-170	55-65	2-20
	50	127-161	200-243	41-52	4-18
	70	158-200	275-315	21-38	8-19
	90	155-175	360-400	30-40	5-15
	110	170-195	460-500	25-35	5-15

Notes: Operating parameters at 3 gpm/ton source and load flow.

7/8/2014

Consult the Capacity Tables for each 504W11 OptiHeat model for normal allowable operating conditions. Some of the conditions shown above are outside of the compressor operational limits for specific models.

Antifreeze Correction

Catalog performance can be corrected for antifreeze use. Please use the following table and note the example given.

Antifreeze Type	Antifreeze % by wt	Heating		Cooling		Pressure Drop
		Load	Source	Load	Source	
EWT - °F [°C]		80 [26.7]	30 [-1.1]	50 [10.0]	90 [32.2]	30 [-1.1]
Water	0	1.000	1.000	1.000	1.000	1.000
Ethylene Glycol	10	0.990	0.973	0.976	0.991	1.075
	20	0.978	0.943	0.947	0.979	1.163
	30	0.964	0.917	0.921	0.965	1.225
	40	0.953	0.890	0.897	0.955	1.324
	50	0.942	0.865	0.872	0.943	1.419
Propylene Glycol	10	0.981	0.958	0.959	0.981	1.130
	20	0.967	0.913	0.921	0.969	1.270
	30	0.946	0.854	0.869	0.950	1.433
	40	0.932	0.813	0.834	0.937	1.614
	50	0.915	0.770	0.796	0.922	1.816
Ethanol	10	0.986	0.927	0.945	0.991	1.242
	20	0.967	0.887	0.906	0.972	1.343
	30	0.944	0.856	0.869	0.947	1.383
	40	0.926	0.815	0.830	0.930	1.523
	50	0.907	0.779	0.795	0.911	1.639
Methanol	10	0.985	0.957	0.962	0.986	1.127
	20	0.969	0.924	0.929	0.970	1.197
	30	0.950	0.895	0.897	0.951	1.235
	40	0.935	0.863	0.866	0.936	1.323
	50	0.919	0.833	0.836	0.920	1.399



WARNING: Gray area represents antifreeze concentrations greater than 35% by weight and should be avoided due to the extreme performance penalty they represent.

Antifreeze Correction Example

Antifreeze solution is propylene glycol 20% by weight for the source and methanol 10% for the load. Determine the corrected heating at 30°F source and 80°F load as well as pressure drop at 30°F for an 050. Also, determine the corrected cooling at 90°F source and 50°F load.

The corrected heating capacity at 30°F/80°F would be:

$$45,600 \text{ BTU/H} \times 0.913 \times 0.985 = 41,008 \text{ BTU/H}$$

The corrected cooling capacity at 90°F/50°F would be:

$$41,700 \times 0.969 \times 0.962 = 38,871 \text{ BTU/H}$$

The corrected pressure drop at 30°F and 15 GPM would be:

$$5.6 \text{ psi} \times 1.270 = 7.11 \text{ psi}$$

Troubleshooting Guideline for Refrigerant Circuit

The chart below will assist in determining if measurements taken at the unit are within factory specifications and aid in accurate diagnosis (SYMPTOM) and repair. The chart is general in nature and represents whether a symptom would result in normal, high, or low readings from the typical operating range.

Symptom	Head Pressure	Suction Pressure	Compressor Amp Draw	Superheat	Subcooling	Water Temp. Differential
Under Charged System (Possible Leak)	Low	Low	Low	High	Low	Low
Over Charged System	High	High	High	Normal	High	Normal
Low Water Flow Evaporator	Low/Normal	Low/Normal	Low	Low	High	High
Low Water Flow Condensor	High	High	High	High	Low	High
High Water Flow Evaporator	Normal	Low	Normal	High	Normal	Low
High Water Flow Condensor	Low	Low	Low	Low	High	Low
Restricted TXV (Check Service Advisory)	High	Low	Normal/Low	High	High	Low
Insufficient Compressor (Possible Bad Valves)	Low	High	Low	High	Normal/High	Low
TXV - Bulb Loss of Charge	Low	Low	Low	High	High	Low
Scaled Coaxial Heat Exchanger Evaporator	Low	Low	Low	Normal/Low	High	Low
Scaled Coaxial Heat Exchanger Condensor	High	High	High	Normal/Low	Low	Low
Restricted Filter Drier	Check temperature difference (delta T) across filter drier.					

7/8/14

HR Data

	Source EST °F	Source GPM	Load Flow - 5 GPM				Load Flow - 8 GPM				Load Flow - 10 GPM				
			ELT 50 °F	ELT 70 °F	ELT 90 °F	ELT 110 °F	ELT 50 °F	ELT 70 °F	ELT 90 °F	ELT 110 °F	ELT 50 °F	ELT 70 °F	ELT 90 °F	ELT 110 °F	
040	50	5.0	34.6	37.1	39.6	42.1	35.2	37.6	40.0	42.4	35.8	38.1	40.4	42.7	
		8.0	33.5	35.7	38.0	40.2	34.0	36.2	38.3	40.5	34.5	36.6	38.7	40.8	
		10.0	32.7	34.8	36.9	39.0	33.1	35.2	37.2	39.3	33.6	35.6	37.6	39.6	
	70	5.0	34.0	37.5	41.0	44.4	34.6	38.1	41.5	44.9	35.2	38.6	42.0	45.3	
		8.0	33.1	36.4	39.6	42.9	33.6	36.9	40.2	43.4	34.2	37.4	40.7	43.9	
		10.0	32.5	35.6	38.8	41.9	33.0	36.1	39.3	42.4	33.5	36.7	39.8	42.9	
	90	5.0	33.4	37.9	42.3	46.7	34.0	38.5	42.9	47.4	34.7	39.1	43.6	48.0	
		8.0	32.7	37.0	41.3	45.6	33.3	37.6	42.0	46.3	33.9	38.3	42.6	47.0	
		10.0	32.2	36.4	40.6	44.8	32.8	37.1	41.3	45.6	33.4	37.7	42.0	46.3	
	110	5.0	32.8	38.2	43.6	49.0	33.5	38.9	44.4	49.9	34.1	39.6	45.2	50.7	
		8.0	32.3	37.7	43.0	48.3	33.0	38.4	43.8	49.2	33.6	39.1	44.6	50.1	
		10.0	32.0	37.3	42.5	47.8	32.7	38.0	43.4	48.8	33.3	38.8	44.3	49.7	
050	50	8.0	Load Flow - 11.5 GPM				Load Flow - 15 GPM				Load Flow - 18.5 GPM				
			ELT 50 °F	ELT 70 °F	ELT 90 °F	ELT 110 °F	ELT 50 °F	ELT 70 °F	ELT 90 °F	ELT 110 °F	ELT 50 °F	ELT 70 °F	ELT 90 °F	ELT 110 °F	
			52.8	56.3	59.7	63.2	53.5	57.0	60.5	64.0	54.1	57.6	61.2	64.7	
	70	8.0	12.0	51.9	55.4	58.9	62.4	52.5	56.0	59.6	63.1	53.1	56.7	60.2	63.8
			15.0	51.1	54.6	58.1	61.5	51.6	55.1	58.7	62.2	52.1	55.7	59.3	62.9
			12.0	48.9	55.5	62.1	68.7	49.5	56.1	62.8	69.4	50.1	56.8	63.4	70.1
	90	8.0	12.0	48.3	54.9	61.6	68.2	48.8	55.5	62.2	68.9	49.4	56.2	62.9	69.7
			15.0	47.7	54.4	61.0	67.7	48.2	55.0	61.7	68.5	48.7	55.6	62.4	69.2
			12.0	45.0	54.7	64.4	74.1	45.5	55.3	65.1	74.8	46.1	55.9	65.7	75.5
	110	8.0	12.0	44.6	54.4	64.2	74.0	45.2	55.0	64.9	74.8	45.7	55.6	65.6	75.5
			15.0	44.3	54.2	64.0	73.9	44.8	54.8	64.7	74.7	45.4	55.4	65.5	75.5
			12.0	41.1	53.9	66.8	79.6	41.5	54.5	67.4	80.3	42.0	55.0	68.0	80.9
110	12.0	12.0	41.0	53.9	66.9	79.8	41.5	54.5	67.6	80.6	42.0	55.1	68.2	81.4	
		15.0	40.9	53.9	67.0	80.0	41.4	54.6	67.8	80.9	42.0	55.3	68.5	81.8	
		15.0	40.9	53.9	67.0	80.0	41.4	54.6	67.8	80.9	42.0	55.3	68.5	81.8	
066	50	10.0	Load Flow - 10 GPM				Load Flow - 15 GPM				Load Flow - 120 GPM				
			ELT 50 °F	ELT 70 °F	ELT 90 °F	ELT 110 °F	ELT 50 °F	ELT 70 °F	ELT 90 °F	ELT 110 °F	ELT 50 °F	ELT 70 °F	ELT 90 °F	ELT 110 °F	
			62.1	66.3	70.5	74.7	62.8	66.9	71.0	75.0	63.6	67.5	71.5	75.4	
	70	10.0	15.0	60.6	64.4	68.3	72.1	61.4	65.1	68.8	72.5	62.1	65.7	69.3	72.9
			20.0	59.2	62.6	66.1	69.5	59.9	63.3	66.6	70.0	60.7	63.9	67.2	70.5
			15.0	60.4	66.1	71.8	77.5	61.4	67.0	72.5	78.1	62.4	67.8	73.2	78.7
	90	10.0	20.0	59.4	64.8	70.1	75.4	60.5	65.6	70.8	76.0	61.5	66.5	71.6	76.6
			15.0	60.7	68.6	76.4	84.3	61.9	69.7	77.4	85.2	63.1	70.7	78.4	86.0
			20.0	59.7	66.9	74.1	81.4	61.0	68.0	75.0	82.1	62.3	69.1	75.9	82.8
	110	10.0	15.0	60.2	67.7	75.3	82.8	61.4	68.8	76.2	83.6	62.7	69.9	77.2	84.4
			20.0	60.0	69.7	79.4	89.2	61.4	71.0	80.6	90.2	62.8	72.3	81.8	91.3
			20.0	60.0	69.4	78.8	88.2	61.5	70.7	79.9	89.2	62.9	72.0	81.1	90.1
110	20.0	20.0	60.0	69.1	78.2	87.3	61.5	70.4	79.2	88.1	63.1	71.7	80.3	88.9	

HE Data

	Source EST °F	Source GPM	Load Flow - 8 GPM					Load Flow - 10 GPM					Load Flow - 12 GPM				
			ELT 60 °F	ELT 80 °F	ELT 100 °F	ELT 130 °F	ELT 140 °F	ELT 60 °F	ELT 80 °F	ELT 100 °F	ELT 130 °F	ELT 140 °F	ELT 60 °F	ELT 80 °F	ELT 100 °F	ELT 130 °F	ELT 140 °F
040	30	5.0	25.8	25.1	23.9	22.5		26.2	25.4	24.3	22.9		26.2	25.4	24.3	22.9	
		8.0	26.5	25.3	24.0	22.0		26.9	25.6	24.4	22.5		26.9	25.6	24.4	22.5	
		10.0	27.0	26.3	24.9	22.8		27.3	26.6	25.3	23.3		27.3	26.6	25.3	23.3	
	50	5.0	31.4	30.9	29.6	28.9		31.7	31.3	30.0	29.3		31.8	31.5	30.2	29.6	
		8.0	32.2	31.0	29.9	28.1		32.6	31.4	30.3	28.6		32.7	31.6	30.5	28.9	
		10.0	32.8	32.3	30.9	29.3		33.1	32.7	31.3	29.8		33.2	32.9	31.5	30.0	
	70	5.0	37.3	36.4	36.0	35.2		37.7	35.9	34.9	33.3		37.8	36.9	34.9	35.3	
		8.0	38.8	38.0	37.2	36.0		38.7	37.0	35.3	32.7		38.8	37.9	37.0	35.7	
		10.0	39.7	38.9	38.5	36.9		39.4	37.5	36.3	33.0		39.5	38.5	36.3	36.0	
	90	5.0	47.6	46.2	45.3	42.1		48.0	46.6	45.7	42.6		48.0	46.6	45.7	42.8	
		8.0	48.8	48.4	47.9			49.2	46.8	44.4	40.9		49.2	48.5	47.8	46.6	
		10.0	49.6	48.1	47.0	42.7		50.0	48.6	47.5	43.2		50.0	48.6	47.5	43.4	
050	30	8.0	34.8	33.2	31.8	29.9		35.4	33.8	32.5	30.7		35.9	34.4	33.1	31.5	
		12.0	35.6	33.7	31.8	29.0		36.2	34.4	32.5	29.8		36.7	35.0	33.2	30.6	
		15.0	36.4	34.8	33.2	30.4		37.0	35.4	33.9	31.2		37.5	36.0	34.6	32.0	
	50	8.0	40.7	39.5	39.2	39.0		41.3	40.2	39.9	39.8		41.9	40.8	40.6	40.7	
		12.0	41.6	40.7	39.7	38.3		42.2	41.3	40.5	39.2		42.8	42.0	41.2	40.1	
		15.0	42.5	41.3	40.8	39.6		43.1	42.0	41.6	40.4		43.7	42.7	42.3	41.3	
	70	8.0	50.1	48.2	47.9	46.0		51.8	49.8	50.8	49.5		53.6	51.3	53.6	52.9	
		12.0	51.6	50.2	48.8	46.6		53.0	51.4	49.9	47.6		54.3	52.6	51.0	48.5	
		15.0	53.1	51.6	51.6	49.5		54.1	52.0	52.8	50.2		55.0	52.4	54.1	50.9	
	90	8.0	61.5	59.5	60.7	56.4		62.1	60.3	61.5	57.3		62.8	61.0	59.2	58.1	
		12.0	62.8	61.4	60.0	57.9		63.4	61.7	60.0	57.4		64.1	62.1	58.7	56.9	
		15.0	64.1	62.1	63.1	57.3		64.8	62.9	63.9	58.2		65.4	63.6	64.7	59.1	
066	30	10.0	43.5	41.3	38.5	35.2		44.1	42.0	39.3	36.2		44.8	42.8	40.2	37.2	35.0
		15.0	44.4	41.6	38.8	34.6		45.1	42.4	39.7	35.6		45.8	43.1	40.4	36.3	34.9
		20.0	45.4	43.2	40.3	35.8		46.1	44.0	41.1	36.8		46.8	44.8	42.0	37.8	35.6
	50	10.0	54.4	53.2	50.5	46.9		55.1	54.1	51.4	48.0		55.9	54.9	52.4	49.2	
		15.0	55.6	53.0	50.5	46.6		56.3	53.9	51.4	47.8		57.1	54.7	52.4	48.9	
		20.0	56.8	55.7	52.7	47.7		57.5	56.5	53.6	48.8		58.0	57.0	54.2	49.3	
	70	10.0	63.7	60.3	57.2	53.1		67.1	64.5	62.2	59.9		70.6	68.7	67.3	67.0	
		15.0	66.0	62.9	59.8	55.1		68.6	66.2	63.8	60.3		71.1	69.5	67.9	65.5	
		20.0	68.4	65.2	62.1	57.3		70.0	67.4	64.8	60.9		71.6	69.5	67.5	64.4	
	90	10.0	76.4	80.2	79.6	74.5		77.3	81.1	80.6	75.7		78.1	82.0	81.7	76.8	
		15.0	78.0	74.4	70.7	65.1		78.9	76.3	73.8	70.0		79.7	78.4	77.0	74.9	
		20.0	79.7	83.6	82.7	75.6		80.5	84.6	83.8	76.8		81.4	85.6	84.8	78.0	

Operation Not Recommended

OptiHeat Sensor Locations

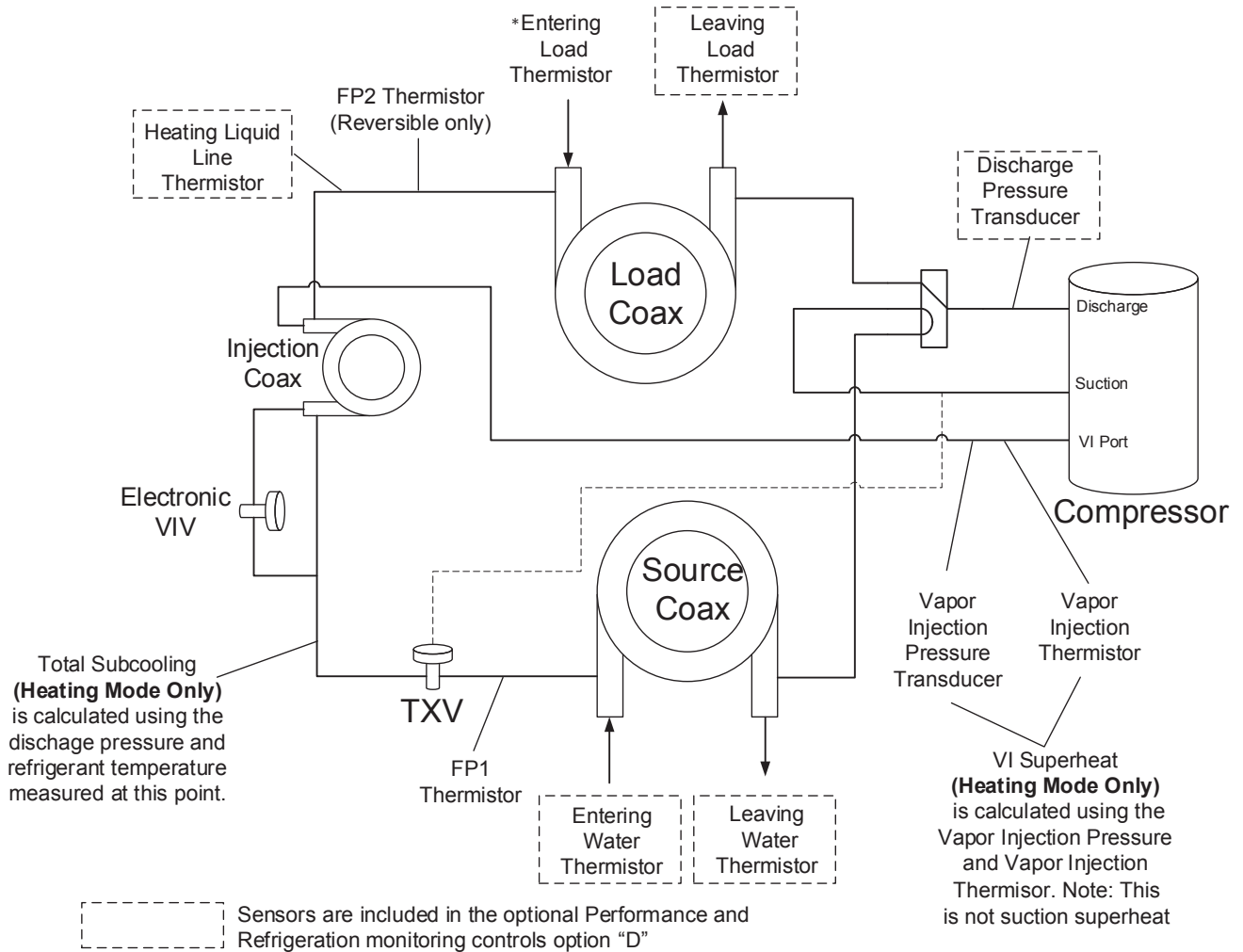

*Only used with HydroStat

Cooling Cycle Analysis

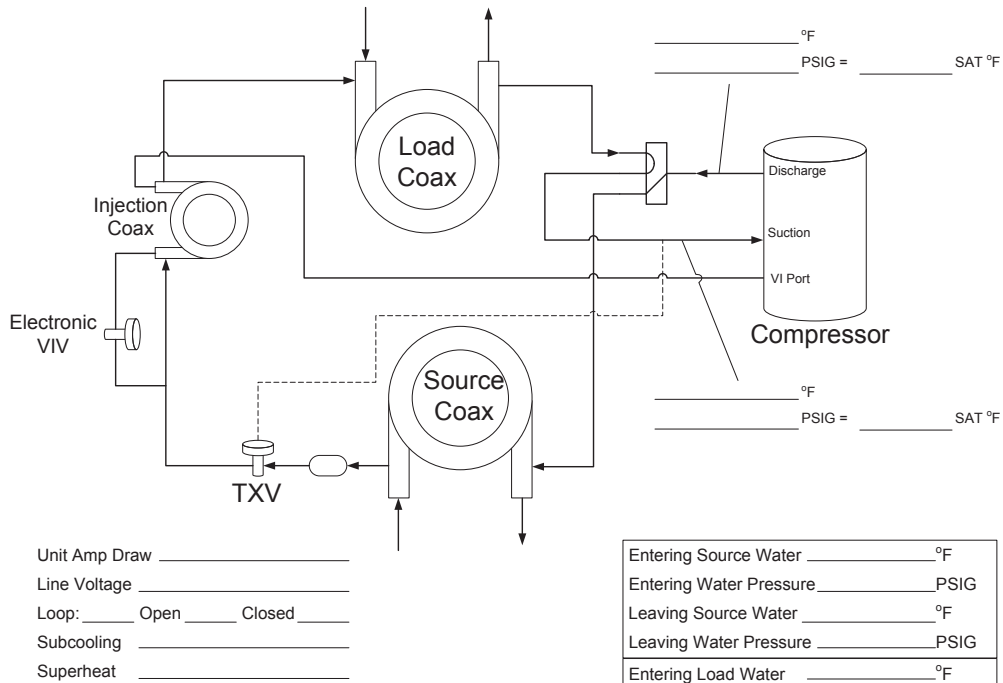

Note: Do not attach refrigerant gauges unless a problem is suspected!
VIV closed in cooling mode!

Heating Cycle Analysis

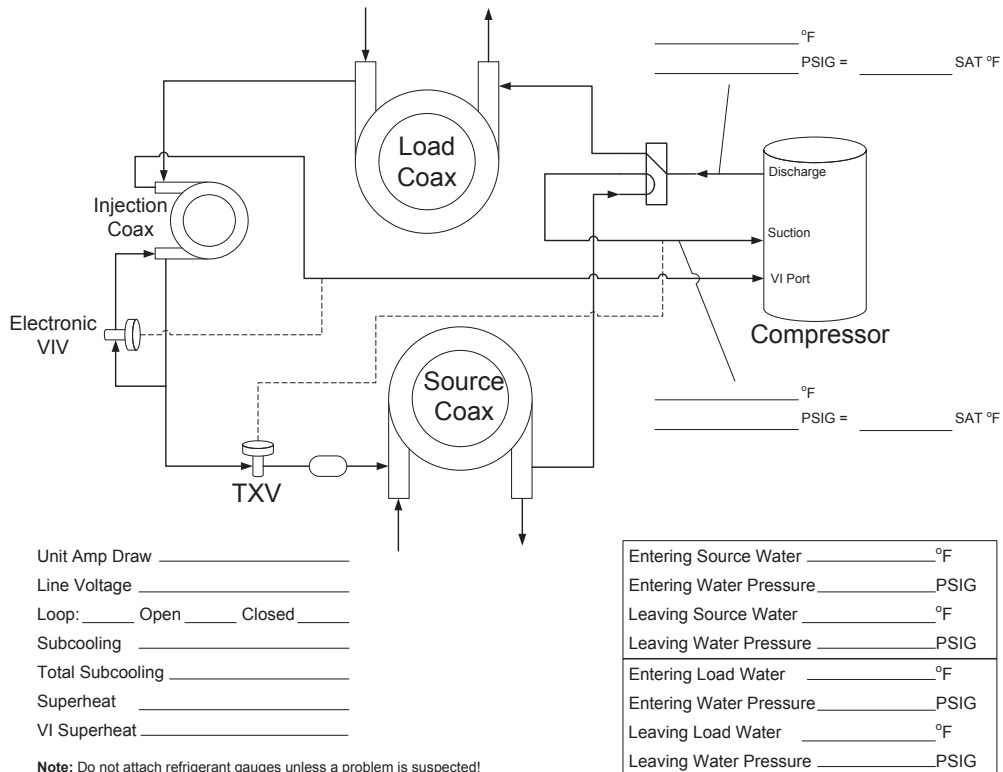

Note: Do not attach refrigerant gauges unless a problem is suspected!

OptiHeat Startup and Troubleshooting Form

Company Name: _____ Company Phone No: _____
 Technician Name: _____ Date: _____
 Model No: _____ Serial No: _____
 Owner's Name: _____ Open or Closed Loop: _____
 Installation Address: _____ Installation Date: _____

Check One

Start up/Check-out for new installation Troubleshooting Problem: _____

1. FLOW RATE IN GPM (SOURCE/LOAD SIDE HEAT EXCHANGER)

Water In Pressure:	a. _____ PSI	a. _____ PSI
Water Out Pressure:	b. _____ PSI	b. _____ PSI
Pressure Drop = a - b	c. _____ PSI	c. _____ PSI
Convert Pressure Drop to Flow Rate (refer to <i>Pressure Drop</i> table)	d. _____ GPM	d. _____ GPM

2. TEMPERATURE RISE OR DROP ACROSS SOURCE SIDE HEAT EXCHANGER

	COOLING	HEATING
Water In Temperature:	e. _____ °F	e. _____ °F
Water Out Temperature:	f. _____ °F	f. _____ °F
Temperature Difference:	g. _____ °F	g. _____ °F

3. TEMPERATURE RISE OR DROP ACROSS LOAD SIDE HEAT EXCHANGER

	COOLING	HEATING
Water In Temperature:	h. _____ °F	h. _____ °F
Water Out Temperature:	i. _____ °F	i. _____ °F
Temperature Difference:	j. _____ °F	j. _____ °F

4. HEAT OF REJECTION (HR) / HEAT OF EXTRACTION (HE) CALCULATION

HR or HE = Flow Rate x Temperature Difference x Brine Factor*
 d. (above) x g. (above) x 485 for Methanol or Environol, 500 for water*
 Heat of Extraction (Heating Mode) = _____ btu/hr
 Heat of Rejection (Cooling Mode) = _____ btu/hr
 Compare results to Capacity Data Tables

Note: Steps 5 through 8 need only be completed if a problem is suspected

5. WATTS

	COOLING	HEATING	HYDRONIC
Volts:	m. _____ VOLTS	m. _____ VOLTS	m. _____ VOLTS
Total Amps (Comp. + Fan):	n. _____ AMPS	n. _____ AMPS	n. _____ AMPS
Watts = m. x n. x 0.85	o. _____ WATTS	o. _____ WATTS	o. _____ WATTS

6. CAPACITY

Cooling Capacity = HR. - (o. x 3.413) p. _____ btu/hr
 Heating Capacity = HE. + (o. x 3.413) p. _____ btu/hr

7. EFFICIENCY

Cooling EER = p. / o. q. _____ EER
 Heating COP = p. / (o. x 3.413) q. _____ COP

8. SUPERHEAT (S.H.) / SUBCOOLING (S.C.)

	COOLING	HEATING	HYDRONIC
Suction Pressure:	r. _____ PSI	r. _____ PSI	r. _____ PSI
Suction Saturation Temperature:	s. _____ °F	s. _____ °F	s. _____ °F
Suction Line Temperature:	t. _____ °F	t. _____ °F	t. _____ °F
Superheat = t. - s.	u. _____ °F	u. _____ °F	u. _____ °F
Head Pressure:	v. _____ PSI	v. _____ PSI	v. _____ PSI
High Pressure Saturation Temp.:	w. _____ °F	w. _____ °F	w. _____ °F
Liquid Line Temperature*:	x. _____ °F	x. _____ °F	x. _____ °F
Subcooling = w. - x.	y. _____ °F	y. _____ °F	y. _____ °F

* Note: Liquid line is between the source heat exchanger and the expansion valve in the cooling mode; between the load heat exchanger and the expansion valve in the heating mode.

Troubleshooting

Should a major problem develop, refer to the following information for possible causes and corrective steps:

Compressor Won't Run

1. The fuse may be blown or the circuit breaker is open. Check electrical circuits and motor windings for shorts or grounds. Investigate for possible overloading. Replace fuse or reset circuit breakers after the fault is corrected.
2. Supply voltage may be too low. Check voltage with a volt meter.
3. Remote control system may be faulty. Check aquastat for correct wiring, setting and calibration. Check 24-volt transformer for burnout.
4. Wires may be loose or broken. Replace or tighten.
5. The low pressure switch may have tripped due to one or more of the following:
 - a. Fouled or plugged coaxial heat exchangers
 - b. Low or no water flow (source side heating, load side cooling)
 - c. Water too cold (source side heating)
 - d. Low refrigerant
6. The high pressure switch may have tripped due to one or more of the following:
 - a. Fouled or plugged coaxial heat exchanger
 - b. Low or no water flow (source side cooling, load side heating)
 - c. Water too warm (source side cooling)
7. Check the capacitor.
8. The compressor overload protection may be open. If the compressor dome is extremely hot, the overload will not reset until cooled down. If the overload does not reset when cool, it may be defective. If so, replace the compressor.
9. The internal winding of the compressor motor may be grounded to the compressor shell. If so, replace the compressor.
10. The compressor winding may be open. Check continuity with an ohm meter. If the winding is open, replace the compressor.

Insufficient Cooling or Heating

1. Check aquastat for improper location.
2. Check for restriction in water flow.
3. Check subcooling for low refrigerant charge.
4. The reversing valve may be defective and creating a bypass of refrigerant. If the unit will not cool, check the reversing valve coil.
5. Check thermal expansion valve for possible restriction of refrigerant flow.

Noisy Unit Operation

1. Check compressor for loosened mounting bolts. Make sure compressor is floating free on its isolator mounts.
2. Check for tubing contact with the compressor or other surfaces. Readjust it by bending slightly.
3. Check screws on all panels.
4. Check for chattering or humming in the contactor or relays due to low voltage or a defective holding coil. Replace the component.
5. Check for proper installation of vibration absorbing material under the unit. Unit must be fully supported, not just on corners.
6. Check for abnormally high discharge pressures.
7. Check that compressor shipping bolt has been removed.

Preventive Maintenance

1. Keep all air out of the water lines. An open loop system should be checked to ensure that the well head is not allowing air to infiltrate the water line. Lines should always be airtight.
2. Keep the system under pressure at all times. In open loop systems, it is recommended that a water control valve be placed in the discharge line to prevent loss of pressure during off cycles. Closed loop systems must have a positive static pressure.

NOTES: If the installation is performed in an area with a known high mineral content in the water, it is best to establish a periodic maintenance schedule to check the water-to-refrigerant heat exchanger on a regular basis. Should periodic cleaning be necessary, use standard cleaning procedures which are compatible with either the cupronickel or copper water lines. Generally, the more water flowing through the unit, the less chance there is for scaling. Low GPM flow rates produce higher temperatures through the coil. To avoid excessive pressure drop and the possibility of copper erosion, do not exceed GPM flow rate as shown on the specification sheets for each unit.

Cleaning Procedure

1. Close the inlet and outlet water valves to isolate the heat pump from the well system, water heater or loop pumps.
2. Disconnect piping and remove solenoid valve, pumps, etc. from the inlet and outlet connections on the heat pump.
3. Connect plastic hoses from the circulating pump* to the outlet of the water-to-refrigerant heat exchanger to be de-limed (refer to the Cleaning Connections illustration).
4. Connect a plastic hose from the circulating pump inlet to the bottom of a plastic five (5) gallon pail (refer to the Cleaning Connections illustration).
5. Connect a plastic hose from the inlet line of the water-to-refrigerant heat exchanger to the plastic pail. Secure tightly to ensure that circulating solution does not spill (refer to the Cleaning Connections illustration).
6. Partially fill the plastic pail with clear water (about two-thirds full) and prime the circulating pump. Circulate until lines are full.
7. Start the circulating pump and slowly add a commercial scale remover** to the water as recommended by the scale remover manufacturer's directions.
8. Be sure the pump circulation is opposite to the normal water flow through the water-to-refrigerant heat exchanger.
9. Maintain re-circulation until all scale and other material has been dissolved and flushed from the heat exchanger.
10. Upon completion of the procedure. Safely dispose of the solution.
11. Rinse the pump and plastic pail. Refill with clear water.
12. Start the pump circulation and flush the system until all acid residue has been removed from the system. Refill the plastic pail until only clear water is circulated.
13. Turn off the circulating pump and disconnect all hoses and fittings.
14. Replace solenoid valves, pumps, hoses and other devices in their original locations. On closed loop systems, be sure to purge between the flow center and unit to avoid getting air into the loop.
15. Put the heat pump back into operation. Check for proper operating temperature.

Cleaning Connections

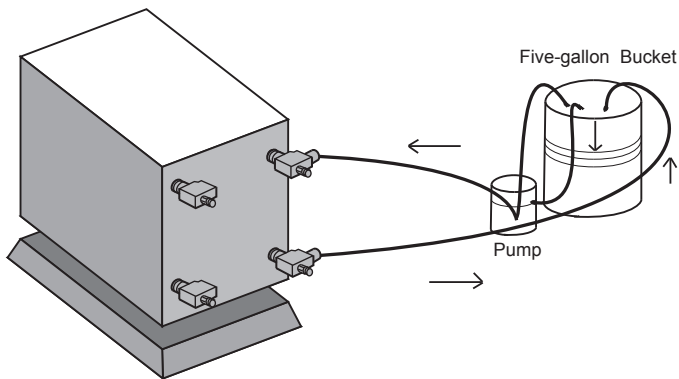

WARNING: This process involves a caustic solution and may be harmful to people and animals. Wear protective equipment (glasses, rubber gloves, apron, etc.)

NOTES: *Virginia Chemical Co. makes a Pump model H460.

* W.W. Granger Co. sells a Pump #2P-017 made by Little Giant.

**Virginia Chemical Co. makes a liquid ice machine cleaner which should be used on water-to-refrigerant heat exchangers serving a domestic hot water system. Calci-Solve by NYCO is available for use on other heat exchangers

Service Parts - Residential

Part Description		040	050	066
		208-230/60/1		
Refrigeration Components	Compressor 208-230/60/1	34P663-01	34P664-01	34P665-01
	Compressor Capacitor 208-230/60/1	16P008D25CK	16P008D41CK	
	Compressor Sound Jacket	92P526-01		
	Thermal Expansion Valve	33P605-10	33P605-15	33P605-07
	VI Electronic Expansion Valve	33P617-01		
	VI Electronic Expansion Valve Solenoid	33P617-04		
	Filter Drier for 'Reversible Models'	36P500B01	36P500B02	
	Filter Drier for 'Heating Only' Models	36P510-01		
	Reversing Valve with Coil	33P503-05	33P526-05	
	Source Coaxial Heat Exchanger (copper)	62I597-01	62I598-01	62I599-01
	Load Coaxial Heat Exchanger (copper)	62I597-01	62I598-01	62I599-01
	VI Coaxial Heat Exchanger	62I617-01		62I596-01
	Safety / Sensor	High Pressure Switch	SKHP650	
Low Pressure Switch		SKLPE40		
Discharge Pressure Transducer		SK5SHPT		
VI Pressure Transducer		SK5SHPT		
Freeze Detection Sensor		12P505-08		
Electrical	Compressor Contactor - 208-230/60/1	13P004A03		
	Transformer - 208-230v	15P501-02		
	Load Pump Relay	13P711-01		
	Current Sensors	12P557-01		
	Pump Power Block	12P500A01		
	Pump Circuit Breaker	19P583-01		
	ABC	17X553-06		
	AXB	17X557-04		
	VI Temperature Sensor	12P555-09		
	IntelliStart Soft Starter	IS1C16-40EN	IS1C16-40EN	
Grounding Lug	12P004A			
Cabinet	Access Panels	40P749-04	40P749-04	40P749-04
	Top Panel	42P548-02	42P548-02	42P548-02

04/28/19

Notes

Revision Guide

Pages:	Description:	Date:	By:
Misc.	Standardized IntelliStart	14 June 2023	JM
4	Updated Nomenclature	01 June 2021	MA
1, 16	3 Inch Larger Cabinet	29 Feb 2020	JM
Misc.	Added Compressor Monitoring kit, misc. updates	5 Oct 2018	JM
All	Literature Creation	5 Feb 2015	MA



Product: **Affinity Series**
Type: Geothermal Hydronic Heat Pump with OptiHeat
Size: 3-5 Ton Single Speed

Document Type: Installation Manual
Part Number: IM2508WK6A
Release Date: 06/23