



Heating and Air Conditioning

SUBMITTAL SET

**AFFINITY OUTDOOR SPLIT
GEOTHERMAL HEAT PUMPS
DUAL CAPACITY**

MODELS:

YAST026 - 072

(2 THRU 6 NOMINAL TONS)



Due to continuous product improvement, specifications are subject to change without notice.

Visit us on the web at www.york-geothermal.com

Additional rating information can found at www.ahridirectory.org

FOR DISTRIBUTION USE ONLY - NOT TO BE USED AT POINT OF RETAIL SALE

Contractor: _____ P.O.: _____

Engineer: _____

Project Name: _____ Unit Tag: _____

**Affinity Dual Capacity
Outdoor Split Series
2 - 6 Tons 60Hz**



Model Nomenclature

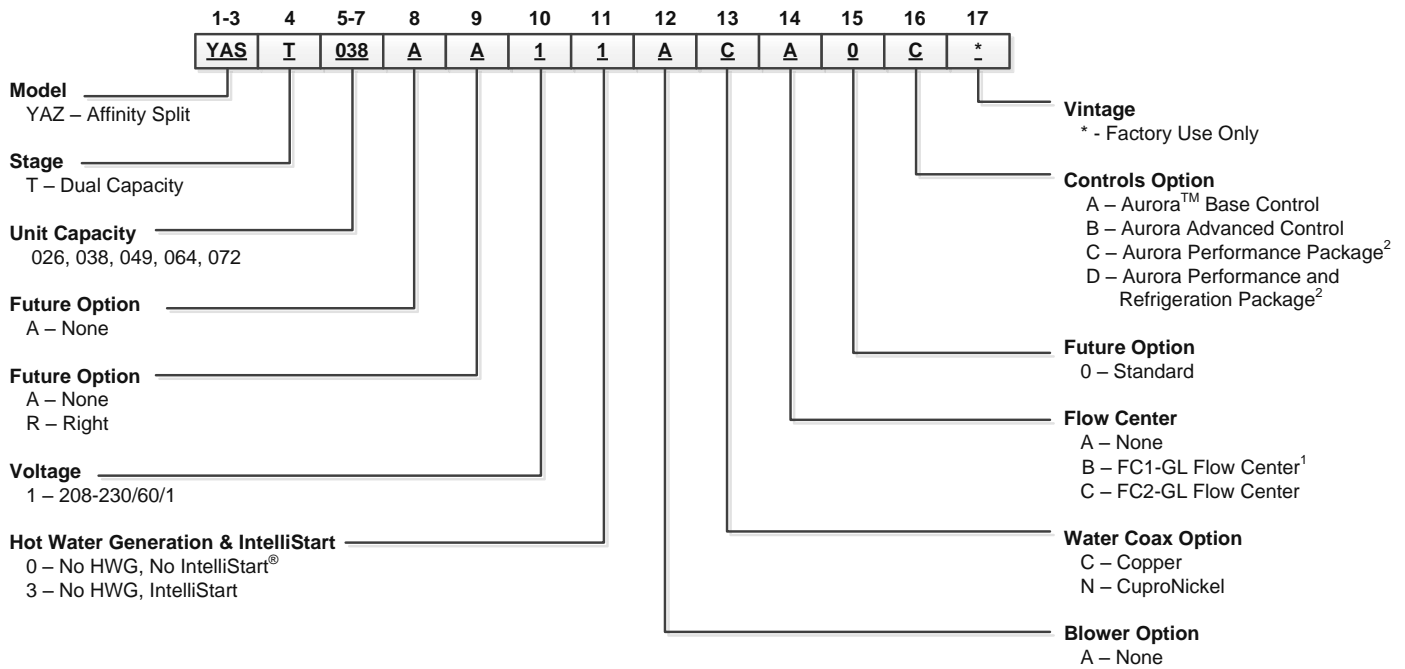

Rev.: 2/9/2017

Note:

- 1 – FC1-GL Not Available on 064-072 Units
- 2 – Performance Package just includes water temperature monitoring.



All Affinity Series product is safety listed under UL1995 thru ETL and performance listed with AHRI in accordance with standard 13256-1. The Affinity Series is also ENERGY STAR® rated.

The manufacturer works continually to improve its products. As a result, the design and specifications of each product at the time of order may be changed without notice. Purchaser's approval of this data set signifies that the equipment is acceptable under the provisions of the job specification. Statements and other information contained herein are not express warranties and do not form the basis of any bargain between the parties, but are merely the manufacturer's opinion or commendation of its products. York and Affinity are registered trademarks of Johnson Controls, Inc., and are used with permission.

Contractor: _____ P.O.: _____

Engineer: _____

Project Name: _____ Unit Tag: _____

**Affinity Dual Capacity
Outdoor Split Series
2 - 6 Tons 60Hz**



AHRI Data

Model	SAH	Capacity Modulation	Flow Rate		Water Loop Heat Pump				Ground Water Heat Pump				Ground Loop Heat Pump			
					Cooling Brine EWT 86°F		Heating Brine EWT 68°F		Cooling EWT 59°F		Heating EWT 50°F		Cooling Brine Full Load 77°F Part Load 68°F		Heating Brine Full Load 32°F Part Load 41°F	
			gpm	cfm	Capacity Btuh	EER Btuh/W	Capacity Btuh	COP	Capacity Btuh	EER Btuh/W	Capacity Btuh	COP	Capacity Btuh	EER Btuh/W	Capacity Btuh	COP
026	026	Full	8	850	22,500	15.0	28,100	5.0	25,800	23.0	23,300	4.6	23,400	17.5	18,400	3.7
		Part	7	750	17,400	17.0	21,200	6.0	20,000	29.0	17,400	5.0	19,200	24.5	15,500	4.3
038	036	Full	9	1200	34,400	16.3	41,600	5.2	38,200	24.2	35,100	4.7	36,000	19.0	27,900	4.0
		Part	8	800	24,600	18.3	30,000	5.4	28,000	32.5	25,100	4.7	27,000	27.0	22,500	4.2
049	048	Full	12	1500	43,200	15.4	56,300	5.1	51,000	24.2	47,100	4.6	46,300	18.0	37,700	3.9
		Part	11	1300	32,500	17.0	41,600	5.9	39,400	31.0	34,000	4.9	37,500	25.8	30,000	4.4
064	060	Full	16	1800	54,800	15.0	66,900	4.8	63,200	22.5	56,000	4.4	57,400	17.0	45,200	3.7
		Part	14	1500	40,900	16.5	48,900	5.4	48,500	29.0	40,100	4.6	46,300	24.5	35,600	4.1
072	066	Full	18	2000	60,400	14.0	81,000	4.5	70,000	22.0	67,500	4.1	62,800	16.0	53,500	3.5
		Part	16	1600	46,600	15.3	61,400	5.2	54,600	26.5	50,800	4.2	51,900	22.0	45,300	3.9

Cooling capacities based upon 80.6°F DB, 66.2°F WB entering air temperature
 Heating capacities based upon 68°F DB, 59°F WB entering air temperature
 All ratings based upon operation at the lower voltage of dual voltage rated models.
 Refer to the air handler compatibility table for matching air handler.

11/21/16

Energy Star Compliance Table

Model	Tier 3	
	Ground Water	Ground Loop
026	Yes	Yes
038	Yes	Yes
049	Yes	Yes
064	Yes	Yes
072	Yes	Yes

11/21/16

Energy Star Rating Criteria

In order for water-source heat pumps to be Energy Star rated they must meet or exceed the minimum efficiency requirements listed below.

Tier 3: 1/1/2012 - No Effective End Date Published

	EER	COP
Closed loop water-to-air	17.1	3.6
Open loop water-to-air	21.1	4.1
Closed loop water-to-water	16.1	3.1
Open loop water-to-water	20.1	3.5



The manufacturer works continually to improve its products. As a result, the design and specifications of each product at the time of order may be changed without notice. Purchaser's approval of this data set signifies that the equipment is acceptable under the provisions of the job specification. Statements and other information contained herein are not express warranties and do not form the basis of any bargain between the parties, but are merely the manufacturer's opinion or commendation of its products. York and Affinity are registered trademarks of Johnson Controls, Inc., and are used with permission.

Contractor: _____ P.O.: _____

Engineer: _____

Project Name: _____ Unit Tag: _____

**Affinity Dual Capacity
Outdoor Split Series
2 - 6 Tons 60Hz**



Dimensional Data

Cabinet Dimensions and Refrigerant Piping Connections

TOP VIEW

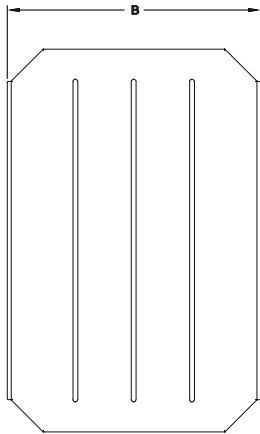

FRONT VIEW

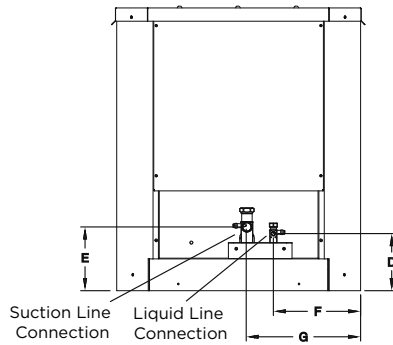

SIDE VIEW

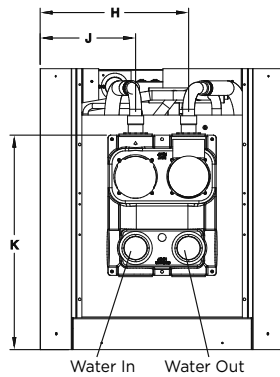
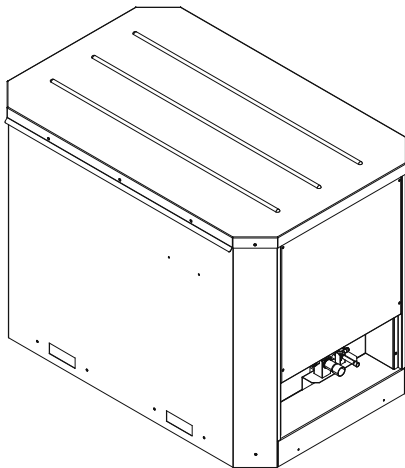
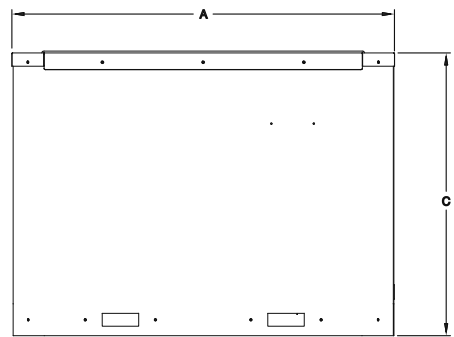

REAR VIEW

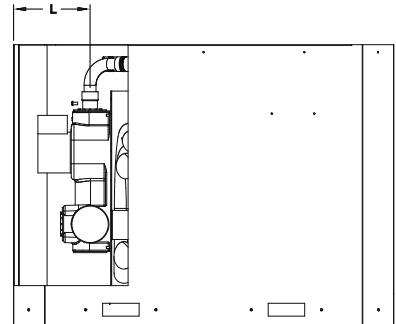

SIDE VIEW

Model		A	B	C	D	E	F	G	H	J	K	L
026 thru 072	in	36.0	23.9	26.7	5.4	6.0	8.2	10.8	14.0	9.0	20.2	7.2
	[cm]	[91.4]	[60.7]	[67.8]	[13.7]	[15.2]	[20.8]	[27.4]	[35.6]	[22.9]	[51.3]	[18.3]

The manufacturer works continually to improve its products. As a result, the design and specifications of each product at the time of order may be changed without notice. Purchaser's approval of this data set signifies that the equipment is acceptable under the provisions of the job specification. Statements and other information contained herein are not express warranties and do not form the basis of any bargain between the parties, but are merely the manufacturer's opinion or commendation of its products. York and Affinity are registered trademarks of Johnson Controls, Inc., and are used with permission.



Contractor: _____ P.O.: _____

Engineer: _____

Project Name: _____ Unit Tag: _____

Physical Data

Model	026	038	049	064	072
Compressor (1 each)	Dual Capacity Scroll				
Factory Charge R-410A, oz [kg]	52 [1.47]	56 [1.59]	90 [2.55]	92 [2.61]	104 [2.95]
Coax and Water Piping					
Water Connections Size - Swivel- in [mm]	GeoLink Swivel Connectors				
Brass Service Valve - Liquid Line - in [mm]	3/8 [9.525]				
Brass Service Valve - Suction Line - in [mm]	5/8 [15.875]	3/4 [19.05]		7/8 [22.225]	
Coax and Piping Water Volume - gal [l]	0.7 [2.6]	1.3 [4.9]	1.6 [6.1]	1.6 [6.1]	1.6 [6.1]
Weight - Operating, lb [kg]	189 [86]	236 [107]	250 [113]	271 [123]	290 [132]
Weight - Packaged, lb [kg]	209 [95]	256 [116]	270 [122]	291 [132]	310 [141]

All units have TXV expansion devices, and 1/2 in. [12.2 mm] and 3/4 in. [19.1 mm] electrical knockouts.
Brass service valves are sweat type valves.

5/24/13

Electrical Data

Model	Rated Voltage	Voltage Min/Max	Compressor				Ext Loop FLA	Total Unit FLA	Min Circ Amp	Max Fuse/HACR
			MCC	RLA	LRA	LRA*				
026	208-230/60/1	187/253	18.2	11.6	58.3	21.0	5.4	17.0	19.9	30
038	208-230/60/1	187/253	23.8	15.2	83.0	30.0	5.4	20.6	24.4	40
049	208-230/60/1	187/253	33.0	21.1	104.0	37.0	5.4	26.5	31.8	50
064	208-230/60/1	187/253	42.3	27.1	152.9	54.0	5.4	32.5	39.3	70
072	208-230/60/1	187/253	46.3	29.6	179.2	63.0	5.4	35.0	42.4	75

Rated voltage of 208-230/60/1.
HACR circuit breaker in USA only.
All fuses Class RK-5
* With optional IntelliStart

4/3/13



Contractor: _____ P.O.: _____

Engineer: _____

Project Name: _____ Unit Tag: _____

Reference Calculations

Heating Calculations:	Cooling Calculations:
$LWT = EWT - \frac{HE}{GPM \times 500}$	$LWT = EWT + \frac{HR}{GPM \times 500}$
$LAT = EAT + \frac{HC}{CFM \times 1.08}$	$LAT (DB) = EAT (DB) - \frac{SC}{CFM \times 1.08}$
$TH = HC + HW$	$LC = TC - SC$
	$S/T = \frac{SC}{TC}$

Legend and Notes

ABBREVIATIONS AND DEFINITIONS:

CFM = airflow, cubic feet/minute	HE = total heat of extraction, MBTUH
EWT = entering water temperature, Fahrenheit	HW = hot water generator capacity, MBTUH
GPM = water flow in gallons/minute	EER = Energy Efficiency Ratio = BTU output/Watt input
WPD = water pressure drop, PSI and feet of water	COP = Coefficient of Performance = BTU output/BTU input
EAT = entering air temperature, Fahrenheit (dry bulb/wet bulb)	LWT = leaving water temperature, °F
HC = air heating capacity, MBTUH	LAT = leaving air temperature, °F
TC = total cooling capacity, MBTUH	TH = total heating capacity, MBTUH
SC = sensible cooling capacity, MBTUH	LC = latent cooling capacity, MBTUH
KW = total power unit input, kilowatts	S/T = sensible to total cooling ratio
HR = total heat of rejection, MBTUH	

Operating Limits

Operating Limits	Cooling	Heating
Air Limits		
Minimum ambient air, DB	-10°F [-23.3°C]	-10°F [-23.3°C]
Rated ambient air, DB	80.0 [26.7°C]	70°F [21.1°C]
Maximum ambient air, DB	120 [48.8°C]	85°F [29°C]
Water Limits		
Minimum entering water	30°F [-1°C]	20°F [-6.7°C]
Normal entering water	50-110°F [10-43°C]	30-70°F [-1 to 21°C]
Maximum entering water	120°F [49°C]	90°F [32°C]
Normal water flow	1.5 to 3.0 gpm per ton [1.6 to 3.2 l/m per kW]	

NOTES: Minimum/maximum limits are only for start-up conditions, and are meant for bringing the space up to occupancy temperature. Units are not designed to operate at the minimum/maximum conditions on a regular basis. The operating limits are dependent upon three primary factors: 1) water temperature, 2) return air temperature, and 3) ambient temperature. When any of the factors are at the minimum or maximum levels, the other two factors must be at the normal level for proper and reliable unit operation.

Contractor: _____ P.O.: _____

Engineer: _____

Project Name: _____ Unit Tag: _____

**Affinity Dual Capacity
Outdoor Split Series
2 - 6 Tons 60Hz**



Pressure Drop

Dual Capacity

Model	GPM	Pressure Drop (psi)				
		30°F	50°F	70°F	90°F	110°F
026 full load	4	1.4	1.3	1.2	1.1	1.0
	6	3.3	3.1	2.9	2.7	2.5
	8	5.1	4.8	4.5	4.2	3.9
	10	7.2	6.9	6.6	6.3	6.0
026 part load	3	1.0	0.9	0.9	0.8	0.7
	5	2.5	2.3	2.2	2.0	1.9
	7	3.9	3.6	3.4	3.2	2.9
	9	6.2	5.9	5.7	5.5	5.2
038 full load	5	1.2	1.2	1.1	1.0	1.0
	7	2.5	2.3	2.2	2.0	1.9
	9	3.6	3.4	3.2	3.0	2.8
	11	5.2	5.0	4.8	4.6	4.4
038 part load	4	0.9	0.9	0.8	0.8	0.7
	6	2.0	1.9	1.8	1.7	1.6
	8	2.9	2.8	2.7	2.5	2.3
	10	4.1	4.0	3.8	3.6	3.4
049 full load	6	1.3	1.2	1.1	1.1	1.0
	9	2.7	2.6	2.4	2.2	2.1
	12	4.2	3.9	3.7	3.3	3.2
	15	6.0	5.7	5.5	5.2	5.0
049 part load	5	0.9	0.8	0.8	0.7	0.7
	8	2.2	2.0	1.9	1.7	1.6
	11	3.5	3.3	3.1	2.8	2.7
	14	5.1	4.9	4.7	4.4	4.2
064 full load	8	1.8	1.7	1.6	1.5	1.4
	12	4.1	3.8	3.6	3.4	3.1
	16	6.5	6.1	5.7	5.3	4.9
	20	9.7	9.2	8.6	8.2	7.6
064 part load	6	1.1	1.0	0.9	0.9	0.8
	10	3.3	3.1	2.9	2.7	2.5
	14	5.6	5.3	4.9	4.6	4.3
	18	8.4	8.1	7.7	7.4	7.1
072 full load	12	3.3	3.1	2.9	2.7	2.5
	15	5.0	4.7	4.4	4.1	3.8
	18	6.8	6.4	6.0	5.5	5.1
	21	8.4	8.0	7.6	7.1	6.8
072 part load	10	2.4	2.3	2.1	2.0	1.8
	13	4.0	3.7	3.5	3.3	3.0
	16	5.6	5.2	4.9	4.6	4.2
	19	7.1	6.8	6.5	6.2	5.9

1/4/17

The manufacturer works continually to improve its products. As a result, the design and specifications of each product at the time of order may be changed without notice. Purchaser's approval of this data set signifies that the equipment is acceptable under the provisions of the job specification. Statements and other information contained herein are not express warranties and do not form the basis of any bargain between the parties, but are merely the manufacturer's opinion or commendation of its products. York and Affinity are registered trademarks of Johnson Controls, Inc., and are used with permission.

Contractor: _____ P.O.: _____

Engineer: _____

Project Name: _____ Unit Tag: _____

**Affinity Dual Capacity
Outdoor Split Series
2 - 6 Tons 60Hz**



Model 026 - Performance Data

026 - Dual Capacity Low Speed

EWT °F	Flow gpm	WPD		HEATING - EAT 70°F						COOLING - EAT 80/67 °F						
		PSI	FT	Airflow cfm	HC MBtuh	Power kW	HE MBtuh	LAT °F	COP	Airflow cfm	TC MBtuh	SC MBtuh	S/T Ratio	Power kW	HR MBtuh	EER
20	3.0	1.0	2.3	Operation not recommended						Operation not recommended						
	5.0	2.6	5.9	Operation not recommended						Operation not recommended						
	7.0	4.0	9.2	500	11.7	1.22	7.6	91.7	2.82	Operation not recommended						
30	3.0	1.0	2.3	Operation not recommended						Operation not recommended						
				500	12.5	1.12	8.7	93.2	3.28	500	17.2	10.2	0.60	0.63	19.3	27.4
	5.0	2.5	5.8	700	13.1	1.15	9.1	87.3	3.32	700	17.5	11.2	0.64	0.66	19.7	26.4
				500	13.7	1.23	9.5	95.4	3.26	500	17.3	10.2	0.59	0.61	19.4	28.3
				700	13.9	1.18	9.9	88.4	3.45	700	17.7	11.2	0.63	0.64	19.9	27.7
40	3.0	1.0	2.2	Operation not recommended						Operation not recommended						
				500	14.9	1.14	11.0	97.5	3.80	500	18.6	12.3	0.66	0.68	21.0	27.2
	5.0	2.4	5.6	700	15.4	1.17	11.4	90.3	3.86	700	19.0	13.5	0.71	0.72	21.4	26.4
				500	15.7	1.17	11.7	99.0	3.91	500	18.8	12.3	0.66	0.66	21.0	28.3
				700	16.2	1.20	12.1	91.4	3.97	700	19.2	13.5	0.70	0.70	21.6	27.6
50	3.0	0.9	2.1	500	16.6	1.17	12.6	100.7	4.16	500	19.6	13.8	0.70	0.76	22.2	25.8
				700	17.1	1.18	13.1	92.6	4.23	700	20.2	15.2	0.75	0.78	22.8	26.0
	5.0	2.3	5.4	500	17.2	1.17	13.2	101.8	4.31	500	19.8	13.8	0.70	0.74	22.3	26.7
				700	17.7	1.18	13.6	93.4	4.38	700	20.4	15.3	0.75	0.76	22.9	26.9
				500	18.0	1.20	13.9	103.3	4.40	500	20.1	14.2	0.70	0.74	22.7	27.4
60	3.0	0.9	2.1	500	18.8	1.19	14.7	104.7	4.60	500	19.1	13.6	0.71	0.86	22.1	22.1
				700	19.2	1.20	15.1	95.4	4.68	700	19.6	15.1	0.77	0.88	22.6	22.3
	5.0	2.3	5.3	500	19.5	1.19	15.4	106.1	4.80	500	19.3	13.7	0.71	0.84	22.2	22.9
				700	20.0	1.20	15.9	96.4	4.88	700	19.8	15.2	0.76	0.86	22.7	23.1
				500	20.2	1.22	16.0	107.4	4.86	500	19.6	14.0	0.72	0.83	22.5	23.5
70	3.0	0.9	2.0	500	20.9	1.22	16.8	108.8	5.02	500	18.6	13.5	0.73	0.97	21.9	19.3
				700	21.3	1.22	17.2	98.2	5.12	700	19.1	14.9	0.78	0.98	22.5	19.4
	5.0	2.2	5.1	500	21.8	1.22	17.7	110.5	5.26	500	18.8	13.6	0.72	0.94	22.0	20.0
				700	22.2	1.22	18.1	99.4	5.37	700	19.3	15.0	0.78	0.96	22.6	20.1
				500	22.4	1.24	18.2	111.5	5.29	500	19.1	13.9	0.73	0.93	22.3	20.5
80	3.0	0.8	1.9	500	23.1	1.25	18.8	112.8	5.42	500	17.2	12.1	0.70	1.09	20.9	15.7
				700	23.4	1.24	19.2	101.0	5.53	700	17.6	13.4	0.76	1.11	21.4	15.9
	5.0	2.1	4.9	500	24.2	1.24	20.0	114.8	5.72	500	17.3	12.2	0.70	1.06	21.0	16.3
				700	24.5	1.23	20.3	102.4	5.83	700	17.8	13.5	0.76	1.08	21.5	16.4
				500	24.5	1.27	20.2	115.5	5.68	500	17.6	12.5	0.71	1.05	21.2	16.7
90	3.0	0.8	1.9	500	25.3	1.28	20.9	116.8	5.80	500	15.7	10.7	0.68	1.22	19.9	12.9
				700	25.5	1.26	21.2	103.7	5.92	700	16.2	11.8	0.73	1.24	20.4	13.0
	5.0	2.0	4.7	500	26.6	1.27	22.2	119.2	6.15	500	15.9	10.7	0.68	1.19	20.1	13.4
				700	26.7	1.25	22.5	105.4	6.28	700	16.3	11.9	0.73	1.21	20.5	13.5
				500	26.7	1.29	22.3	119.4	6.06	500	16.2	11.0	0.68	1.18	20.2	13.7
100	3.0	0.8	1.8	Operation not recommended						Operation not recommended						
				500	14.9	1.15	11.5	97.5	3.80	500	14.9	11.5	0.77	1.38	19.6	10.8
	5.0	2.0	4.6	700	15.3	1.17	11.8	90.3	3.86	700	15.3	12.7	0.83	1.41	20.1	10.9
				500	15.1	1.18	11.8	97.5	3.80	500	15.1	11.8	0.78	1.37	19.8	11.1
				700	15.6	1.21	12.1	91.4	3.97	700	15.6	13.1	0.84	1.40	20.3	11.1
110	3.0	0.7	1.7	Operation not recommended						Operation not recommended						
				Operation not recommended						Operation not recommended						
	5.0	1.9	4.4	500	13.9	1.12	8.7	93.2	3.28	500	13.9	12.2	0.88	1.57	19.2	8.8
				700	14.3	1.15	9.1	87.3	3.32	700	14.3	13.6	0.95	1.60	19.7	8.9
				500	14.1	1.26	12.6	95.4	3.26	500	14.1	12.6	0.89	1.56	19.4	9.0
120	3.0	0.7	1.7	Operation not recommended						Operation not recommended						
				Operation not recommended						Operation not recommended						
	5.0	1.8	4.2	500	13.1	1.12	8.7	93.2	3.28	500	13.1	12.2	0.93	1.81	19.3	7.2
				700	13.3	1.15	9.1	87.3	3.32	700	13.3	13.2	0.99	1.86	19.7	7.2
				500	13.2	1.27	12.6	95.4	3.26	500	13.2	12.2	0.92	1.75	19.2	7.5
7.0	2.8	6.5	500	13.5	1.29	12.9	103.3	4.40	500	13.5	13.2	0.98	1.81	19.7	7.5	
			Operation not recommended						Operation not recommended							

1/4/17

Multiple Flow Rates (for EWT) are shown in the table above. The lowest flow rate shown is used for geothermal open loop/well water systems with a minimum 50° F. The second flow rate shown is the minimum geothermal closed loop flow rate. The third flow rate shown is optimum for geothermal closed loop and the suggested flow rate for boiler tower applications.

The manufacturer works continually to improve its products. As a result, the design and specifications of each product at the time of order may be changed without notice. Purchaser's approval of this data set signifies that the equipment is acceptable under the provisions of the job specification. Statements and other information contained herein are not express warranties and do not form the basis of any bargain between the parties, but are merely the manufacturer's opinion or commendation of its products. York and Affinity are registered trademarks of Johnson Controls, Inc., and are used with permission.



Contractor: _____ P.O.: _____

Engineer: _____

Project Name: _____ Unit Tag: _____

Model 026 - Performance Data

026 - Dual Capacity High Speed

EWT °F	Flow gpm	WPD		HEATING - EAT 70°F						COOLING - EAT 80/67 °F						
		PSI	FT	Airflow cfm	HC MBtuh	Power kW	HE MBtuh	LAT °F	COP	Airflow cfm	TC MBtuh	SC MBtuh	S/T Ratio	Power kW	HR MBtuh	EER
20	4.0	1.4	3.2	Operation not recommended						Operation not recommended						
	6.0	3.4	7.8	Operation not recommended						Operation not recommended						
	8.0	5.3	12.2	700	16.0	1.49	10.9	91.1	3.14	Operation not recommended						
				900	16.4	1.50	11.3	86.9	3.20	Operation not recommended						
30	4.0	1.4	3.2	Operation not recommended						Operation not recommended						
	6.0	3.3	7.6	700	18.2	1.50	13.1	94.1	3.56	700	23.0	14.0	0.61	1.00	26.4	23.0
				900	18.7	1.54	13.5	89.3	3.55	900	23.4	15.3	0.65	1.06	27.0	22.2
	8.0	5.1	11.8	700	18.6	1.55	13.3	94.6	3.52	700	23.1	14.0	0.61	0.97	26.5	23.8
				900	19.1	1.56	13.8	89.7	3.59	900	23.7	15.3	0.65	1.02	27.2	23.2
40	4.0	1.3	3.1	Operation not recommended						Operation not recommended						
	6.0	3.2	7.4	700	20.9	1.57	15.5	97.6	3.90	700	25.0	16.4	0.66	1.10	28.8	22.6
				900	21.5	1.60	16.0	92.1	3.94	900	25.5	17.9	0.70	1.16	29.4	22.0
	8.0	5.0	11.5	700	21.3	1.58	15.9	98.1	3.94	700	25.2	16.4	0.65	1.07	28.8	23.5
				900	22.0	1.62	16.4	92.6	3.98	900	25.8	17.9	0.70	1.12	29.6	23.0
50	4.0	1.3	3.0	700	22.7	1.60	17.2	100.0	4.16	700	25.6	17.1	0.67	1.26	29.9	20.3
				900	23.4	1.62	17.8	94.0	4.23	900	26.9	19.0	0.71	1.33	31.5	20.3
	6.0	3.1	7.2	700	23.5	1.63	17.9	101.1	4.22	700	26.2	17.3	0.66	1.19	30.2	22.0
				900	24.3	1.66	18.6	95.0	4.30	900	27.5	19.2	0.70	1.25	31.8	22.0
	8.0	4.8	11.1	700	24.0	1.65	18.4	101.8	4.28	700	26.4	18.5	0.70	1.16	30.4	22.7
			900	24.8	1.67	19.1	95.5	4.35	900	27.8	20.5	0.74	1.22	32.0	22.8	
60	4.0	1.2	2.9	700	25.0	1.67	19.3	103.0	4.39	700	25.0	17.2	0.69	1.38	29.7	18.1
				900	25.8	1.68	20.0	96.5	4.50	900	26.2	19.1	0.73	1.44	31.1	18.2
	6.0	3.0	6.9	700	26.1	1.71	20.2	104.5	4.46	700	25.6	17.4	0.68	1.31	30.0	19.5
				900	26.9	1.73	21.0	97.7	4.57	900	26.8	19.3	0.72	1.36	31.4	19.6
	8.0	4.7	10.8	700	26.7	1.73	20.8	105.3	4.52	700	25.8	18.3	0.71	1.28	30.2	20.2
			900	27.6	1.74	21.7	98.4	4.65	900	27.1	20.3	0.75	1.34	31.7	20.3	
70	4.0	1.2	2.8	700	27.3	1.74	21.3	106.1	4.60	700	24.4	17.2	0.71	1.49	29.5	16.3
				900	28.6	1.81	22.4	99.4	4.63	900	25.5	19.2	0.75	1.55	30.7	16.4
	6.0	2.9	6.7	700	28.7	1.80	22.5	107.9	4.68	700	25.0	17.4	0.70	1.43	29.9	17.5
				900	29.6	1.80	23.5	100.5	4.83	900	26.1	19.3	0.74	1.48	31.1	17.6
	8.0	4.5	10.4	700	29.4	1.82	23.2	108.9	4.74	700	25.3	18.1	0.72	1.39	30.0	18.1
			900	30.4	1.81	24.2	101.3	4.92	900	26.4	20.1	0.76	1.45	31.3	18.2	
80	4.0	1.2	2.7	700	29.5	1.81	23.3	109.0	4.77	700	22.8	17.1	0.75	1.65	28.4	13.8
				900	30.5	1.80	24.4	101.4	4.98	900	23.7	19.1	0.80	1.70	29.5	14.0
	6.0	2.8	6.5	700	31.2	1.88	24.8	111.3	4.85	700	23.4	17.4	0.74	1.59	28.9	14.7
				900	32.3	1.87	25.9	103.2	5.07	900	24.4	19.2	0.79	1.64	30.0	14.9
	8.0	4.3	10.0	700	32.1	1.91	25.6	112.5	4.93	700	23.7	17.8	0.75	1.56	29.0	15.2
			900	33.2	1.88	26.8	104.2	5.18	900	24.7	19.7	0.80	1.61	30.1	15.4	
90	4.0	1.1	2.6	700	31.7	1.89	25.3	112.0	4.93	700	21.2	17.1	0.80	1.80	27.4	11.8
				900	32.9	1.86	26.5	103.8	5.19	900	22.0	18.9	0.86	1.85	28.3	11.9
	6.0	2.7	6.2	700	33.7	1.97	27.0	114.6	5.02	700	21.8	17.3	0.79	1.75	27.8	12.5
				900	34.9	1.94	28.3	105.9	5.29	900	22.6	19.2	0.85	1.80	28.8	12.6
	8.0	4.2	9.7	700	34.8	2.00	28.0	116.0	5.10	700	22.2	17.1	0.77	1.66	27.9	13.4
			900	36.0	1.95	29.3	107.0	5.41	900	22.9	19.3	0.84	1.76	28.9	13.0	
100	4.0	1.1	2.5	Operation not recommended						Operation not recommended						
	6.0	2.6	6.0	Operation not recommended						700	20.8	16.9	0.81	1.96	27.5	10.6
				Operation not recommended						900	21.5	18.8	0.87	1.99	28.3	10.8
	8.0	4.0	9.3	Operation not recommended						700	21.1	16.9	0.80	1.93	27.7	10.9
			Operation not recommended						900	21.8	18.7	0.86	1.96	28.4	11.1	
110	4.0	1.0	2.4	Operation not recommended						Operation not recommended						
	6.0	2.5	5.8	Operation not recommended						700	19.9	16.5	0.83	2.18	27.3	9.1
				Operation not recommended						900	20.4	18.4	0.90	2.19	27.9	9.3
	8.0	3.9	9.0	Operation not recommended						700	20.1	16.3	0.81	2.14	27.6	9.4
			Operation not recommended						900	20.6	18.0	0.87	2.16	28.0	9.5	
120	4.0	1.0	2.3	Operation not recommended						Operation not recommended						
	6.0	2.4	5.6	Operation not recommended						700	17.9	16.2	0.91	2.40	26.1	7.4
				Operation not recommended						900	18.2	17.6	0.97	2.47	26.6	7.4
	8.0	3.7	8.6	Operation not recommended						700	18.0	16.2	0.90	2.33	26.0	7.7
			Operation not recommended						900	18.4	17.6	0.96	2.40	26.6	7.7	

1/4/17

Multiple Flow Rates (for EWT) are shown in the table above. The lowest flow rate shown is used for geothermal open loop/well water systems with a minimum 50° F. The second flow rate shown is the minimum geothermal closed loop flow rate. The third flow rate shown is optimum for geothermal closed loop and the suggested flow rate for boiler tower applications.

The manufacturer works continually to improve its products. As a result, the design and specifications of each product at the time of order may be changed without notice. Purchaser's approval of this data set signifies that the equipment is acceptable under the provisions of the job specification. Statements and other information contained herein are not express warranties and do not form the basis of any bargain between the parties, but are merely the manufacturer's opinion or commendation of its products. York and Affinity are registered trademarks of Johnson Controls, Inc., and are used with permission.

Contractor: _____ P.O.: _____

Engineer: _____

Project Name: _____ Unit Tag: _____

**Affinity Dual Capacity
Outdoor Split Series
2 - 6 Tons 60Hz**



Model 038 - Performance Data

038 - Dual Capacity Low Speed

EWT °F	Flow gpm	WPD		HEATING - EAT 70°F						COOLING - EAT 80/67 °F							
		PSI	FT	Airflow cfm	HC MBtuh	Power kW	HE MBtuh	LAT °F	COP	Airflow cfm	TC MBtuh	SC MBtuh	S/T Ratio	Power kW	HR MBtuh	EER	
20	4.0	1.0	2.2	Operation not recommended						Operation not recommended							
	6.0	2.1	4.9	Operation not recommended						Operation not recommended							
	8.0	3.1	7.2	800	17.2	1.69	11.4	89.9	2.97	Operation not recommended							
				1000	17.5	1.70	11.7	86.2	3.02	Operation not recommended							
30	4.0	0.9	2.2	Operation not recommended						Operation not recommended							
	6.0	2.0	4.7	800	18.3	1.65	12.7	91.2	3.25	800	23.4	13.6	0.58	0.84	26.3	27.7	
				1000	19.1	1.70	13.3	87.7	3.29	1000	23.8	14.9	0.63	0.89	26.8	26.7	
	8.0	3.0	7.0	800	19.9	1.73	14.0	93.0	3.37	800	23.5	13.6	0.58	0.82	26.6	28.7	
				1000	20.3	1.74	14.4	88.8	3.42	1000	24.1	14.9	0.62	0.86	27.0	28.0	
40	4.0	0.9	2.1	Operation not recommended						Operation not recommended							
	6.0	2.0	4.6	800	21.6	1.68	15.9	95.1	3.77	800	26.2	16.9	0.65	0.93	29.4	28.3	
				1000	22.4	1.71	16.6	90.7	3.83	1000	26.7	18.5	0.69	0.97	30.0	27.5	
	8.0	2.9	6.7	800	22.8	1.72	16.9	96.4	3.88	800	26.4	16.9	0.64	0.90	29.5	29.4	
				1000	23.6	1.76	17.6	91.9	3.94	1000	27.0	18.5	0.69	0.94	30.2	28.7	
50	4.0	0.9	2.0	800	24.1	1.71	18.3	97.9	4.14	800	28.4	19.4	0.68	1.04	31.9	27.4	
				1000	24.9	1.73	19.0	93.0	4.21	1000	29.2	21.4	0.73	1.06	32.8	27.6	
	6.0	1.9	4.4	800	25.0	1.71	19.1	98.9	4.28	800	28.6	19.5	0.68	1.01	32.1	28.4	
				1000	25.7	1.73	19.8	93.8	4.35	1000	29.4	21.5	0.73	1.03	32.9	28.6	
	8.0	2.8	6.5	800	26.1	1.75	20.2	100.2	4.38	800	29.1	20.0	0.69	1.00	32.5	29.1	
1000				26.9	1.77	20.9	94.9	4.45	1000	29.9	22.1	0.74	1.02	33.4	29.3		
60	4.0	0.9	2.0	800	27.3	1.75	21.3	101.6	4.56	800	27.9	19.6	0.70	1.18	31.9	23.6	
				1000	28.0	1.77	21.9	95.9	4.64	1000	28.7	21.7	0.76	1.21	32.8	23.8	
	6.0	1.9	4.3	800	28.4	1.75	22.4	102.9	4.75	800	28.1	19.7	0.70	1.15	32.1	24.4	
				1000	29.1	1.76	23.1	96.9	4.83	1000	28.9	21.8	0.75	1.18	32.9	24.6	
	8.0	2.7	6.3	800	29.4	1.79	23.3	104.0	4.81	800	28.6	20.2	0.71	1.14	32.5	25.0	
1000				30.1	1.80	23.9	97.8	4.89	1000	29.4	22.4	0.76	1.17	33.4	25.2		
70	4.0	0.8	1.9	800	30.5	1.80	24.3	105.3	4.96	800	27.4	19.8	0.72	1.33	32.0	20.6	
				1000	31.1	1.81	24.9	98.8	5.04	1000	28.2	21.9	0.78	1.36	32.8	20.8	
	6.0	1.8	4.2	800	31.8	1.79	25.7	106.8	5.19	800	27.7	19.9	0.72	1.30	32.1	21.3	
				1000	32.4	1.79	26.3	100.0	5.29	1000	28.4	22.0	0.78	1.32	32.9	21.5	
	8.0	2.7	6.1	800	32.6	1.83	26.4	107.8	5.22	800	28.1	20.4	0.73	1.29	32.5	21.9	
1000				33.2	1.83	27.0	100.7	5.32	1000	28.9	22.6	0.78	1.31	33.4	22.1		
80	4.0	0.8	1.9	800	33.3	1.83	27.1	108.6	5.34	800	25.6	19.4	0.76	1.53	30.8	16.8	
				1000	33.8	1.82	27.6	101.3	5.44	1000	26.3	21.5	0.82	1.56	31.6	16.9	
	6.0	1.7	4.0	800	34.9	1.82	28.7	110.4	5.63	800	25.8	19.5	0.76	1.49	30.9	17.4	
				1000	35.4	1.81	29.2	102.7	5.74	1000	26.6	21.6	0.81	1.52	31.7	17.5	
	8.0	2.6	5.9	800	35.4	1.86	29.1	111.0	5.59	800	26.3	20.0	0.76	1.48	31.3	17.8	
1000				35.8	1.84	29.5	103.1	5.70	1000	27.0	22.2	0.82	1.51	32.1	17.9		
90	4.0	0.8	1.8	800	36.2	1.86	29.9	111.9	5.71	800	23.8	19.0	0.80	1.73	29.7	13.8	
				1000	36.5	1.84	30.2	103.8	5.82	1000	24.5	21.0	0.86	1.76	30.5	13.9	
	6.0	1.7	3.9	800	38.1	1.84	31.8	114.1	6.05	800	24.0	19.1	0.80	1.68	29.8	14.3	
				1000	38.3	1.82	32.1	105.5	6.18	1000	24.7	21.2	0.86	1.72	30.5	14.4	
	8.0	2.5	5.7	800	38.2	1.88	32.0	114.2	5.96	800	24.2	19.3	0.80	1.65	30.0	14.7	
1000				38.4	1.85	32.1	105.6	6.08	1000	25.1	21.7	0.86	1.70	30.9	14.8		
100	4.0	0.7	1.7	Operation not recommended						Operation not recommended							
	6.0	1.6	3.7	800	22.5	18.5	0.82	1.93	29.1	11.7	800	22.5	18.5	0.82	1.93	29.1	11.7
				1000	23.2	20.5	0.89	1.96	29.9	11.8	1000	23.2	20.5	0.89	1.96	29.9	11.8
	8.0	2.4	5.5	800	22.9	19.0	0.83	1.91	29.4	12.0	800	22.9	19.0	0.83	1.91	29.4	12.0
				1000	23.6	21.1	0.89	1.95	30.2	12.1	1000	23.6	21.1	0.89	1.95	30.2	12.1
110	4.0	0.7	1.7	Operation not recommended						Operation not recommended							
	6.0	1.6	3.6	800	21.1	18.0	0.85	2.17	28.5	9.7	800	21.1	18.0	0.85	2.17	28.5	9.7
				1000	21.6	19.9	0.92	2.21	29.2	9.8	1000	21.6	19.9	0.92	2.21	29.2	9.8
	8.0	2.3	5.3	800	21.4	18.4	0.86	2.15	28.7	10.0	800	21.4	18.4	0.86	2.15	28.7	10.0
				1000	22.0	20.4	0.93	2.19	29.5	10.0	1000	22.0	20.4	0.93	2.19	29.5	10.0
120	4.0	0.7	1.6	Operation not recommended						Operation not recommended							
	6.0	1.5	3.5	800	18.8	16.2	0.86	2.49	27.3	7.5	800	18.8	16.2	0.86	2.49	27.3	7.5
				1000	19.2	17.6	0.92	2.56	27.9	7.5	1000	19.2	17.6	0.92	2.56	27.9	7.5
	8.0	2.2	5.1	800	19.0	16.2	0.85	2.41	27.2	7.9	800	19.0	16.2	0.85	2.41	27.2	7.9
				1000	19.4	17.6	0.91	2.49	27.9	7.8	1000	19.4	17.6	0.91	2.49	27.9	7.8

1/4/17

Multiple Flow Rates (for EWT) are shown in the table above. The lowest flow rate shown is used for geothermal open loop/well water systems with a minimum 50° F. The second flow rate shown is the minimum geothermal closed loop flow rate. The third flow rate shown is optimum for geothermal closed loop and the suggested flow rate for boiler tower applications.

The manufacturer works continually to improve its products. As a result, the design and specifications of each product at the time of order may be changed without notice. Purchaser's approval of this data set signifies that the equipment is acceptable under the provisions of the job specification. Statements and other information contained herein are not express warranties and do not form the basis of any bargain between the parties, but are merely the manufacturer's opinion or commendation of its products. York and Affinity are registered trademarks of Johnson Controls, Inc., and are used with permission.



Contractor: _____ P.O.: _____

Engineer: _____

Project Name: _____ Unit Tag: _____

Model 038 - Performance Data

038 - Dual Capacity High Speed

EWT °F	Flow gpm	WPD		HEATING - EAT 70°F						COOLING - EAT 80/67 °F						
		PSI	FT	Airflow cfm	HC MBtuh	Power kW	HE MBtuh	LAT °F	COP	Airflow cfm	TC MBtuh	SC MBtuh	S/T Ratio	Power kW	HR MBtuh	EER
20	5.0	1.3	3.0	Operation not recommended												
	7.0	2.6	5.9	Operation not recommended												
	9.0	3.7	8.7	1000	24.3	2.22	16.7	92.5	3.21	Operation not recommended						
30	5.0	1.2	2.9	Operation not recommended						Operation not recommended						
				1000	28.2	2.29	20.4	96.1	3.62	1000	30.4	18.5	0.61	1.41	35.2	21.5
	7.0	2.5	5.8	1200	29.0	2.36	21.0	92.4	3.61	1200	30.9	20.2	0.65	1.49	36.0	20.7
				1000	28.9	2.36	20.8	96.8	3.59	1000	30.6	18.5	0.61	1.37	35.4	22.3
				1200	29.6	2.38	21.5	92.8	3.65	1200	31.3	20.2	0.65	1.44	36.2	21.7
40	5.0	1.2	2.8	Operation not recommended						Operation not recommended						
				1000	31.9	2.39	23.8	99.6	3.91	1000	33.6	20.5	0.61	1.56	38.9	21.6
	7.0	2.4	5.6	1200	32.9	2.44	24.6	95.4	3.95	1200	34.2	22.4	0.65	1.63	39.8	21.0
				1000	32.6	2.41	24.3	100.2	3.95	1000	33.8	20.5	0.61	1.51	39.0	22.4
				1200	33.6	2.47	25.2	95.9	3.99	1200	34.6	22.4	0.65	1.58	40.0	21.9
50	5.0	1.2	2.7	1000	34.4	2.44	26.1	101.9	4.14	1000	34.9	20.5	0.59	1.78	41.0	19.6
				1200	35.4	2.47	27.0	97.3	4.20	1200	36.7	22.8	0.62	1.87	43.1	19.6
	7.0	2.3	5.4	1000	35.7	2.49	27.1	103.0	4.19	1000	35.7	20.7	0.58	1.68	41.4	21.2
				1200	36.8	2.53	28.2	98.4	4.27	1200	37.5	23.0	0.61	1.76	43.5	21.3
				1000	36.5	2.52	27.9	103.8	4.25	1000	36.0	22.1	0.62	1.64	41.6	22.0
60	5.0	1.1	2.6	1000	37.2	2.53	28.6	104.5	4.32	1000	35.5	22.7	0.64	1.96	42.2	18.1
				1200	38.4	2.54	29.7	99.6	4.43	1200	37.2	25.2	0.68	2.04	44.2	18.2
	7.0	2.3	5.3	1000	38.9	2.60	30.0	106.0	4.39	1000	36.3	22.9	0.63	1.86	42.7	19.5
				1200	40.2	2.61	31.2	101.0	4.50	1200	38.1	25.4	0.67	1.94	44.7	19.7
				1000	39.8	2.62	30.9	106.9	4.45	1000	36.7	24.2	0.66	1.81	42.9	20.2
70	5.0	1.1	2.5	1000	40.1	2.61	31.2	107.1	4.50	1000	36.1	24.9	0.69	2.13	43.4	16.9
				1200	42.7	2.67	33.6	102.9	4.69	1200	37.7	27.7	0.73	2.21	45.2	17.0
	7.0	2.2	5.1	1000	42.1	2.70	32.9	109.0	4.58	1000	37.0	25.2	0.68	2.04	44.0	18.2
				1200	43.5	2.70	34.3	103.6	4.73	1200	38.6	27.9	0.72	2.11	45.8	18.3
				1000	43.2	2.73	33.9	110.0	4.64	1000	37.4	26.2	0.70	1.99	44.2	18.8
80	5.0	1.1	2.5	1000	43.3	2.73	34.0	110.1	4.65	1000	34.8	24.6	0.71	2.34	42.8	14.8
				1200	44.8	2.71	35.6	104.6	4.85	1200	36.2	27.3	0.76	2.41	44.4	15.0
	7.0	2.1	4.9	1000	45.8	2.84	36.1	112.4	4.73	1000	35.7	24.9	0.70	2.26	43.4	15.8
				1200	47.3	2.81	37.7	106.5	4.94	1200	37.2	27.6	0.74	2.33	45.1	16.0
				1000	47.1	2.87	37.3	113.6	4.80	1000	36.1	25.5	0.71	2.21	43.7	16.3
90	5.0	1.0	2.4	1000	46.5	2.84	36.8	113.0	4.79	1000	33.4	24.3	0.73	2.55	42.1	13.1
				1200	48.1	2.80	38.6	107.1	5.04	1200	34.6	27.0	0.78	2.62	43.5	13.2
	7.0	2.0	4.7	1000	49.4	2.97	39.2	115.7	4.87	1000	34.4	24.6	0.71	2.48	42.9	13.9
				1200	51.1	2.92	41.2	109.5	5.14	1200	35.7	27.3	0.76	2.54	44.4	14.0
				1000	50.9	3.01	40.7	117.2	4.95	1000	35.2	25.2	0.72	2.37	43.3	14.9
100	5.0	1.0	2.3	Operation not recommended												
				1000	31.6	2.40	24.0	96.7	3.77	1000	31.6	24.0	0.76	2.77	41.0	11.4
	7.0	2.0	4.6	1200	32.6	2.67	26.7	96.7	3.81	1200	32.6	26.7	0.82	2.81	42.2	11.6
				1000	31.9	2.40	24.0	96.7	3.77	1000	31.9	24.0	0.75	2.72	41.2	11.7
				1200	33.0	2.65	26.5	96.7	3.81	1200	33.0	26.5	0.80	2.76	42.4	11.9
110	5.0	1.0	2.2	Operation not recommended												
				1000	28.7	2.34	23.4	92.2	3.05	1000	28.7	23.4	0.82	3.05	39.1	9.4
	7.0	1.9	4.4	1200	29.5	2.60	26.0	92.2	3.07	1200	29.5	26.0	0.88	3.07	40.0	9.6
				1000	29.0	2.31	23.1	92.2	3.00	1000	29.0	23.1	0.80	3.00	39.2	9.7
				1200	29.8	2.55	25.5	92.2	3.03	1200	29.8	25.5	0.86	3.03	40.1	9.8
120	5.0	0.9	2.1	Operation not recommended												
				1000	26.9	2.28	22.8	85.3	3.38	1000	26.9	22.8	0.85	3.38	38.4	8.0
	7.0	1.8	4.2	1200	27.4	2.47	24.7	85.3	3.46	1200	27.4	24.7	0.90	3.46	39.2	7.9
				1000	27.1	2.28	22.8	85.3	3.27	1000	27.1	22.8	0.84	3.27	38.3	8.3
				1200	27.7	2.47	24.7	85.3	3.37	1200	27.7	24.7	0.89	3.37	39.2	8.2

1/4/17

Multiple Flow Rates (for EWT) are shown in the table above. The lowest flow rate shown is used for geothermal open loop/well water systems with a minimum 50° F. The second flow rate shown is the minimum geothermal closed loop flow rate. The third flow rate shown is optimum for geothermal closed loop and the suggested flow rate for boiler tower applications.

The manufacturer works continually to improve its products. As a result, the design and specifications of each product at the time of order may be changed without notice. Purchaser's approval of this data set signifies that the equipment is acceptable under the provisions of the job specification. Statements and other information contained herein are not express warranties and do not form the basis of any bargain between the parties, but are merely the manufacturer's opinion or commendation of its products. York and Affinity are registered trademarks of Johnson Controls, Inc., and are used with permission.

Contractor: _____ P.O.: _____

Engineer: _____

Project Name: _____ Unit Tag: _____

**Affinity Dual Capacity
Outdoor Split Series
2 - 6 Tons 60Hz**



Model 049 - Performance Data

049 - Dual Capacity Low Speed

EWT °F	Flow gpm	WPD		HEATING - EAT 70°F						COOLING - EAT 80/67 °F							
		PSI	FT	Airflow cfm	HC MBtuh	Power kW	HE MBtuh	LAT °F	COP	Airflow cfm	TC MBtuh	SC MBtuh	S/T Ratio	Power kW	HR MBtuh	EER	
20	5.0	0.9	2.1	Operation not recommended						Operation not recommended							
	8.0	2.2	5.1	Operation not recommended						Operation not recommended							
	11.0	3.6	8.4	1200	21.1	2.25	13.4	86.3	2.75	Operation not recommended							
30	5.0	0.9	2.1	Operation not recommended						Operation not recommended							
				Operation not recommended						Operation not recommended							
	8.0	2.2	5.0	1200	25.1	2.28	17.3	89.3	3.22	1200	34.3	22.1	0.64	1.22	38.4	28.2	
				1400	25.8	2.30	18.0	87.1	3.29	1400	34.8	24.1	0.69	1.28	39.2	27.2	
				1200	26.0	2.30	18.2	90.1	3.31	1200	34.5	22.1	0.64	1.18	38.5	29.2	
11.0	3.5	8.2	1400	26.6	2.33	18.7	87.6	3.35	1400	35.3	24.1	0.68	1.24	39.5	28.5		
40	5.0	0.9	2.0	Operation not recommended						Operation not recommended							
				Operation not recommended						Operation not recommended							
	8.0	2.1	4.8	1200	30.9	2.34	22.9	93.8	3.86	1200	37.4	25.5	0.68	1.35	42.0	27.8	
				1400	32.0	2.34	24.0	91.2	4.00	1400	38.1	27.8	0.73	1.41	42.9	27.0	
				1200	31.9	2.36	23.9	94.6	3.96	1200	37.7	25.5	0.68	1.31	42.1	28.9	
11.0	3.4	7.9	1400	33.0	2.38	24.9	91.8	4.07	1400	38.5	27.8	0.72	1.37	43.2	28.2		
50	5.0	0.8	2.0	1200	34.1	2.33	26.1	96.3	4.29	1200	39.4	26.6	0.68	1.74	45.3	22.7	
				1400	35.2	2.33	27.2	93.3	4.43	1400	40.6	31.4	0.77	1.81	46.8	22.4	
	8.0	2.0	4.7	1200	36.7	2.40	28.5	98.4	4.48	1200	40.2	26.7	0.66	1.50	45.4	26.7	
				1400	38.1	2.39	30.0	95.2	4.68	1400	41.5	31.5	0.76	1.58	46.8	26.3	
				1200	38.1	2.42	29.9	99.4	4.62	1200	40.5	26.7	0.66	1.42	45.6	28.6	
11.0	3.3	7.7	1400	39.4	2.42	31.1	96.1	4.77	1400	41.7	31.5	0.76	1.49	46.8	28.0		
60	5.0	0.8	1.9	1200	36.3	2.40	28.1	98.0	4.43	1200	37.0	26.2	0.71	1.91	43.5	19.3	
				1400	37.6	2.38	29.4	94.8	4.62	1400	38.2	30.9	0.81	2.00	45.0	19.1	
	8.0	2.0	4.5	1200	39.2	2.46	30.8	100.3	4.68	1200	37.6	26.4	0.70	1.70	43.4	22.1	
				1400	40.8	2.43	32.5	97.0	4.92	1400	38.8	31.1	0.80	1.78	44.8	21.8	
				1200	40.9	2.48	32.4	101.6	4.83	1200	38.0	26.5	0.70	1.61	43.5	23.6	
11.0	3.2	7.4	1400	42.4	2.45	34.0	98.0	5.07	1400	39.2	31.2	0.79	1.69	44.9	23.3		
70	5.0	0.8	1.8	1200	38.5	2.47	30.1	99.7	4.57	1200	34.6	25.8	0.75	2.09	41.8	16.6	
				1400	42.0	2.46	33.6	97.8	5.00	1400	35.7	30.4	0.85	2.19	43.2	16.3	
	8.0	1.9	4.4	1200	41.8	2.51	33.2	102.2	4.88	1200	35.0	26.1	0.75	1.89	42.0	18.5	
				1400	43.4	2.47	35.0	98.7	5.16	1400	36.1	30.7	0.85	1.98	42.8	18.2	
				1200	43.7	2.54	35.0	103.7	5.04	1200	35.6	26.2	0.74	1.81	42.3	19.7	
11.0	3.1	7.2	1400	45.3	2.48	36.8	100.0	5.35	1400	36.7	30.8	0.84	1.88	43.1	19.5		
80	5.0	0.8	1.8	1200	41.3	2.50	32.7	101.9	4.83	1200	32.4	24.7	0.76	2.33	40.4	13.9	
				1400	42.9	2.46	34.5	98.4	5.11	1400	33.4	29.1	0.87	2.43	41.7	13.8	
	8.0	1.8	4.2	1200	44.8	2.53	36.2	104.6	5.19	1200	32.6	25.0	0.77	2.16	40.0	15.1	
				1400	46.7	2.47	38.2	100.9	5.54	1400	33.6	29.4	0.88	2.25	41.2	14.9	
				1200	47.1	2.56	38.4	106.4	5.39	1200	33.3	25.2	0.76	2.07	40.4	16.1	
11.0	3.0	6.9	1400	49.0	2.49	40.5	102.4	5.77	1400	34.4	29.6	0.86	2.16	41.7	15.9		
90	5.0	0.7	1.7	1200	44.1	2.54	35.4	104.0	5.08	1200	30.2	23.6	0.78	2.56	38.3	11.8	
				1400	45.8	2.49	37.3	100.3	5.40	1400	31.2	27.7	0.89	2.67	40.3	11.7	
	8.0	1.8	4.1	1200	47.9	2.56	39.2	107.0	5.50	1200	30.2	23.9	0.79	2.43	38.5	12.4	
				1400	49.9	2.47	41.5	103.0	5.92	1400	31.0	28.1	0.91	2.52	39.6	12.3	
				1200	50.6	2.58	41.8	109.0	5.74	1200	31.5	26.3	0.83	2.35	39.5	13.4	
11.0	2.9	6.7	1400	52.7	2.50	44.2	104.9	6.18	1400	32.0	28.4	0.89	2.43	40.3	13.2		
100	5.0	0.7	1.6	Operation not recommended						Operation not recommended							
	8.0	1.7	3.9	Operation not recommended						Operation not recommended							
	11.0	2.8	6.5	1200	27.5	2.24	0.81	2.73	36.9	10.1	1400	28.4	26.4	0.93	2.84	38.1	10.0
110	5.0	0.7	1.6	Operation not recommended						Operation not recommended							
				Operation not recommended						Operation not recommended							
	8.0	1.6	3.8	1200	24.9	2.09	0.84	3.04	35.3	8.2	1400	25.7	24.6	0.96	3.16	36.5	8.1
				1200	26.1	21.3	0.82	2.94	36.1	8.9	1200	26.1	21.3	0.82	2.94	36.1	8.9
				1400	26.8	25.0	0.93	3.07	37.3	8.7	1400	26.8	25.0	0.93	3.07	37.3	8.7
11.0	2.7	6.2	Operation not recommended						Operation not recommended								
120	5.0	0.7	1.5	Operation not recommended						Operation not recommended							
				Operation not recommended						Operation not recommended							
	8.0	1.6	3.6	1200	23.9	21.4	0.90	3.45	35.6	6.9	1400	24.3	23.2	0.95	3.54	36.4	6.9
				1200	24.1	21.4	0.89	3.34	35.5	7.2	1400	24.6	23.2	0.94	3.44	36.3	7.2

1/4/17

Multiple Flow Rates (for EWT) are shown in the table above. The lowest flow rate shown is used for geothermal open loop/well water systems with a minimum 50° F. The second flow rate shown is the minimum geothermal closed loop flow rate. The third flow rate shown is optimum for geothermal closed loop and the suggested flow rate for boiler tower applications.

The manufacturer works continually to improve its products. As a result, the design and specifications of each product at the time of order may be changed without notice. Purchaser's approval of this data set signifies that the equipment is acceptable under the provisions of the job specification. Statements and other information contained herein are not express warranties and do not form the basis of any bargain between the parties, but are merely the manufacturer's opinion or commendation of its products. York and Affinity are registered trademarks of Johnson Controls, Inc., and are used with permission.

Contractor: _____ P.O.: _____

Engineer: _____

Project Name: _____ Unit Tag: _____

**Affinity Dual Capacity
Outdoor Split Series
2 - 6 Tons 60Hz**



Model 049 - Performance Data

NDS049 - Dual Capacity High Speed

EWT °F	Flow gpm	WPD		HEATING - EAT 70°F						COOLING - EAT 80/67 °F							
		PSI	FT	Airflow cfm	HC MBtuh	Power kW	HE MBtuh	LAT °F	COP	Airflow cfm	TC MBtuh	SC MBtuh	S/T Ratio	Power kW	HR MBtuh	EER	
20	6.0	1.3	3.1	Operation not recommended						Operation not recommended							
	9.0	2.8	6.5	Operation not recommended						Operation not recommended							
	12.0	4.3	9.9	1400	35.6	2.95	25.5	93.5	3.53	Operation not recommended							
30	6.0	1.3	3.0	Operation not recommended						Operation not recommended							
				Operation not recommended						Operation not recommended							
	9.0	2.7	6.3	1400	37.1	3.15	26.4	94.5	3.45	1400	42.2	29.5	0.70	1.85	48.5	22.9	
				1600	38.3	3.17	27.4	92.1	3.53	1600	42.9	32.2	0.75	1.94	49.6	22.1	
	12.0	4.2	9.6	1400	38.3	3.14	27.6	95.3	3.57	1400	42.5	29.5	0.69	1.79	48.6	23.7	
1600				39.4	3.22	28.4	92.8	3.59	1600	43.5	32.2	0.74	1.88	49.9	23.1		
40	6.0	1.2	2.9	Operation not recommended						Operation not recommended							
				Operation not recommended						Operation not recommended							
	9.0	2.6	6.1	1400	42.0	3.28	30.8	97.8	3.76	1400	46.5	32.5	0.70	2.11	53.7	22.0	
				1600	43.5	3.28	32.3	95.2	3.89	1600	47.4	35.5	0.75	2.22	54.9	21.4	
	12.0	4.0	9.3	1400	43.4	3.30	32.1	98.7	3.85	1400	46.9	32.5	0.69	2.05	53.9	22.8	
1600				44.9	3.32	33.5	96.0	3.96	1600	47.9	35.5	0.74	2.15	55.2	22.3		
50	6.0	1.2	2.8	1400	43.5	3.29	32.3	98.8	3.88	1400	49.4	32.8	0.66	2.81	58.0	17.6	
				1600	44.9	3.29	33.7	96.0	4.00	1600	50.9	38.6	0.76	2.93	60.5	17.4	
	9.0	2.6	5.9	1400	46.9	3.40	35.3	101.0	4.05	1400	50.5	32.9	0.65	2.43	58.6	20.7	
				1600	48.7	3.38	37.2	98.2	4.23	1600	52.0	38.8	0.75	2.55	60.7	20.4	
	12.0	3.9	9.1	1400	48.7	3.42	37.0	102.2	4.17	1400	50.8	32.9	0.65	2.29	58.8	22.2	
1600				50.3	3.42	38.6	99.1	4.31	1600	52.3	38.8	0.74	2.41	60.9	21.7		
60	6.0	1.2	2.7	1400	47.7	3.47	35.8	101.5	4.03	1400	48.0	32.1	0.67	2.99	58.2	16.1	
				1600	49.4	3.45	37.6	98.6	4.20	1600	49.5	37.9	0.77	3.12	60.1	15.9	
	9.0	2.5	5.7	1400	51.6	3.56	39.5	104.1	4.25	1400	48.7	32.4	0.66	2.65	57.8	18.4	
				1600	53.6	3.51	41.6	101.0	4.47	1600	50.2	38.1	0.76	2.77	59.7	18.1	
	12.0	3.8	8.8	1400	53.8	3.59	41.6	105.6	4.39	1400	49.3	32.5	0.66	2.52	57.9	19.6	
1600				55.7	3.55	43.6	102.2	4.61	1600	50.8	38.2	0.75	2.63	59.8	19.3		
70	6.0	1.1	2.6	1400	51.9	3.65	39.4	104.3	4.17	1400	46.5	31.5	0.68	3.17	57.2	14.7	
				1600	57.3	3.58	45.1	103.2	4.69	1600	48.0	37.1	0.77	3.32	58.3	14.5	
	9.0	2.4	5.5	1400	56.3	3.71	43.6	107.2	4.45	1400	47.0	31.9	0.68	2.87	57.8	16.4	
				1600	58.5	3.65	46.1	103.9	4.70	1600	48.5	37.4	0.77	3.00	58.7	16.2	
	12.0	3.7	8.5	1400	58.9	3.76	46.1	108.9	4.60	1400	47.8	32.0	0.67	2.74	57.9	17.4	
1600				61.1	3.67	48.6	105.4	4.88	1600	49.3	37.6	0.76	2.85	59.0	17.3		
80	6.0	1.1	2.5	1400	55.6	3.83	42.5	106.7	4.26	1400	43.8	30.5	0.70	3.36	54.3	13.0	
				1600	57.7	3.76	44.9	103.4	4.50	1600	45.2	35.9	0.79	3.51	56.2	12.9	
	9.0	2.3	5.4	1400	60.3	3.87	47.1	109.9	4.57	1400	44.1	30.9	0.70	3.12	54.7	14.1	
				1600	62.8	3.77	49.9	106.3	4.88	1600	45.4	36.3	0.80	3.25	56.5	14.0	
	12.0	3.5	8.2	1400	63.4	3.91	50.1	111.9	4.75	1400	45.1	31.1	0.69	2.99	55.2	15.1	
1600				66.0	3.81	53.0	108.2	5.08	1600	46.5	36.6	0.79	3.11	57.1	14.9		
90	6.0	1.1	2.4	1400	59.2	4.01	45.6	109.2	4.33	1400	41.1	29.5	0.72	3.55	53.3	11.6	
				1600	61.5	3.92	48.2	105.6	4.60	1600	42.5	34.7	0.82	3.70	55.1	11.5	
	9.0	2.2	5.2	1400	64.4	4.03	50.7	112.6	4.69	1400	41.1	29.9	0.73	3.37	53.6	12.2	
				1600	67.1	3.90	53.8	108.8	5.04	1600	42.3	35.2	0.83	3.49	54.2	12.1	
	12.0	3.4	7.9	1400	68.0	4.07	54.1	114.9	4.89	1400	42.9	33.3	0.78	3.27	54.1	13.1	
1600				70.8	3.94	57.4	111.0	5.27	1600	43.6	35.5	0.81	3.37	55.1	12.9		
100	6.0	1.0	2.3	Operation not recommended						Operation not recommended							
	9.0	2.2	5.0	Operation not recommended						Operation not recommended							
				Operation not recommended						Operation not recommended							
	12.0	3.3	7.6	1400	38.5	28.9	0.75	3.71	51.1	10.4	1400	38.5	28.9	0.75	3.71	51.1	10.4
				1600	39.6	34.1	0.86	3.86	52.8	10.3	1600	39.6	34.1	0.86	3.86	52.8	10.3
110	6.0	1.0	2.3	Operation not recommended						Operation not recommended							
				Operation not recommended						Operation not recommended							
	9.0	2.1	4.8	Operation not recommended						Operation not recommended							
				Operation not recommended						Operation not recommended							
	12.0	3.2	7.3	Operation not recommended						Operation not recommended							
Operation not recommended						Operation not recommended											
120	6.0	0.9	2.2	Operation not recommended						Operation not recommended							
				Operation not recommended						Operation not recommended							
	9.0	2.0	4.6	Operation not recommended						Operation not recommended							
				Operation not recommended						Operation not recommended							
	12.0	3.0	7.0	Operation not recommended						Operation not recommended							
Operation not recommended						Operation not recommended											

1/4/17

Multiple Flow Rates (for EWT) are shown in the table above. The lowest flow rate shown is used for geothermal open loop/well water systems with a minimum 50° F. The second flow rate shown is the minimum geothermal closed loop flow rate. The third flow rate shown is optimum for geothermal closed loop and the suggested flow rate for boiler tower applications.

The manufacturer works continually to improve its products. As a result, the design and specifications of each product at the time of order may be changed without notice. Purchaser's approval of this data set signifies that the equipment is acceptable under the provisions of the job specification. Statements and other information contained herein are not express warranties and do not form the basis of any bargain between the parties, but are merely the manufacturer's opinion or commendation of its products. York and Affinity are registered trademarks of Johnson Controls, Inc., and are used with permission.

Contractor: _____ P.O.: _____

Engineer: _____

Project Name: _____ Unit Tag: _____

**Affinity Dual Capacity
Outdoor Split Series
2 - 6 Tons 60Hz**



Model 064 - Performance Data

064 - Dual Capacity Low Speed

EWT °F	Flow gpm	WPD		HEATING - EAT 70°F					COOLING - EAT 80/67 °F							
		PSI	FT	Airflow cfm	HC MBtuh	Power kW	HE MBtuh	LAT °F	COP	Airflow cfm	TC MBtuh	SC MBtuh	S/T Ratio	Power kW	HR MBtuh	EER
20	6.0	1.1	2.5	Operation not recommended					Operation not recommended							
	10.0	3.4	7.8	Operation not recommended					Operation not recommended							
	14.0	5.8	13.4	1200	26.2	2.79	16.7	90.2	2.76	Operation not recommended						
				1500	26.9	2.80	17.3	86.6	2.82	Operation not recommended						
30	6.0	1.1	2.5	Operation not recommended					Operation not recommended							
	10.0	3.3	7.6	1200	30.1	2.85	20.4	93.3	3.10	1200	43.4	26.3	0.61	1.50	48.5	28.9
				1500	31.2	2.89	21.4	89.3	3.17	1500	44.1	28.7	0.65	1.58	49.5	27.9
	14.0	5.6	13.0	1200	31.5	2.88	21.7	94.3	3.21	1200	43.6	26.3	0.60	1.46	48.6	29.9
1500				32.3	2.89	22.4	89.9	3.28	1500	44.7	28.7	0.64	1.53	49.9	29.2	
40	6.0	1.0	2.4	Operation not recommended					Operation not recommended							
	10.0	3.2	7.4	1200	35.5	2.93	25.5	97.4	3.55	1200	47.0	29.7	0.63	1.67	52.7	28.2
				1500	36.4	2.94	26.4	92.5	3.64	1500	47.9	32.5	0.68	1.75	53.9	27.4
	14.0	5.4	12.6	1200	36.6	2.94	26.6	98.3	3.66	1200	47.4	29.7	0.63	1.62	52.9	29.3
1500				37.6	2.95	27.6	93.2	3.74	1500	48.5	32.5	0.67	1.69	54.2	28.7	
50	6.0	1.0	2.3	1200	40.1	2.95	30.1	101.0	3.99	1200	50.5	31.6	0.63	1.87	56.4	27.0
				1500	41.2	2.95	31.1	95.4	4.10	1500	51.9	35.9	0.69	1.97	58.2	26.4
	10.0	3.1	7.2	1200	40.7	3.00	30.5	101.4	3.98	1200	50.6	31.9	0.63	1.80	56.7	28.1
				1500	41.7	2.98	31.5	95.7	4.09	1500	52.1	36.2	0.70	1.88	58.5	27.6
14.0	5.3	12.2	1200	42.0	3.02	31.7	102.4	4.08	1200	50.7	31.9	0.63	1.77	56.9	28.7	
			1500	42.9	3.00	32.7	96.5	4.19	1500	52.2	36.2	0.69	1.85	28.7	28.2	
60	6.0	1.0	2.2	1200	44.9	3.02	34.6	104.7	4.35	1200	48.3	30.9	0.64	2.12	55.4	22.8
				1500	45.9	3.00	35.6	98.3	4.48	1500	49.8	34.9	0.70	2.22	57.0	22.4
	10.0	3.0	6.9	1200	46.3	3.08	35.8	105.7	4.41	1200	48.5	31.2	0.64	2.05	55.6	23.6
				1500	47.0	3.03	36.7	99.0	4.55	1500	50.0	35.2	0.70	2.15	57.3	23.3
14.0	5.1	11.8	1200	47.4	3.10	36.8	106.6	4.48	1200	48.7	31.3	0.64	2.01	55.7	24.2	
			1500	48.2	3.06	37.7	99.7	4.61	1500	50.2	35.3	0.70	2.11	57.4	23.8	
70	6.0	0.9	2.2	1200	49.7	3.10	39.1	108.4	4.70	1200	46.2	30.2	0.65	2.38	54.3	19.4
				1500	49.6	3.07	39.1	100.6	4.74	1500	47.6	33.9	0.71	2.48	56.1	19.2
	10.0	2.9	6.7	1200	51.8	3.15	41.1	110.0	4.82	1200	46.5	30.5	0.66	2.31	54.4	20.1
				1500	52.4	3.09	41.9	102.4	4.98	1500	47.9	34.3	0.72	2.41	56.1	19.9
14.0	4.9	11.4	1200	52.8	3.19	42.0	110.8	4.85	1200	46.8	30.6	0.65	2.26	54.5	20.7	
			1500	53.4	3.12	42.8	103.0	5.02	1500	48.2	34.4	0.71	2.36	56.3	20.4	
80	6.0	0.9	2.1	1200	53.6	3.17	42.8	111.4	4.96	1200	43.1	28.6	0.66	2.71	52.3	15.9
				1500	54.1	3.10	43.5	103.4	5.12	1500	44.4	31.9	0.72	2.81	53.9	15.8
	10.0	2.8	6.5	1200	56.6	3.22	45.6	113.7	5.16	1200	43.4	28.9	0.66	2.64	52.5	16.4
				1500	56.9	3.12	46.2	105.1	5.34	1500	44.7	32.3	0.72	2.75	54.1	16.3
14.0	4.8	11.0	1200	57.3	3.26	46.2	114.2	5.15	1200	43.7	29.1	0.66	2.60	52.6	16.8	
			1500	57.5	3.17	46.7	105.5	5.32	1500	45.1	32.5	0.72	2.70	54.3	16.7	
90	6.0	0.9	2.0	1200	57.5	3.23	46.5	114.3	5.22	1200	39.9	27.0	0.68	3.05	50.3	13.1
				1500	57.6	3.14	46.9	105.6	5.37	1500	41.1	30.0	0.73	3.13	51.8	13.1
	10.0	2.7	6.2	1200	61.3	3.28	50.1	117.3	5.48	1200	40.4	27.2	0.67	2.98	50.5	13.6
				1500	61.3	3.16	50.6	107.9	5.69	1500	41.6	30.3	0.73	3.08	52.1	13.5
14.0	4.6	10.6	1200	61.7	3.33	50.4	117.6	5.44	1200	40.2	28.0	0.70	2.94	50.7	13.7	
			1500	61.6	3.21	50.6	108.0	5.62	1500	42.0	30.6	0.73	3.03	52.3	13.9	
100	6.0	0.8	2.0	Operation not recommended					Operation not recommended							
	10.0	2.6	6.0	Operation not recommended					1200	37.6	26.3	0.70	3.40	49.2	11.1	
				1500	38.7	29.1	0.75	3.49	50.7	11.1						
	14.0	4.4	10.3	Operation not recommended					1200	38.0	26.6	0.70	3.35	49.4	11.3	
1500				39.2	29.5	0.75	3.44	50.9	11.4							
110	6.0	0.8	1.9	Operation not recommended					Operation not recommended							
	10.0	2.5	5.8	Operation not recommended					1200	34.8	25.4	0.73	3.82	47.9	9.1	
				1500	35.9	27.9	0.78	3.90	49.2	9.2						
	14.0	4.3	9.9	Operation not recommended					1200	35.3	25.8	0.73	3.76	48.2	9.4	
1500				36.4	28.3	0.78	3.84	49.5	9.5							
120	6.0	0.8	1.8	Operation not recommended					Operation not recommended							
	10.0	2.4	5.6	Operation not recommended					1200	31.8	24.0	0.76	4.35	46.7	7.3	
				1500	32.4	26.1	0.81	4.46	47.6	7.3						
	14.0	4.1	9.5	Operation not recommended					1200	32.1	24.0	0.75	4.21	46.5	7.6	
1500				32.8	26.1	0.80	4.34	47.6	7.6							

1/4/17

Multiple Flow Rates (for EWT) are shown in the table above. The lowest flow rate shown is used for geothermal open loop/well water systems with a minimum 50° F. The second flow rate shown is the minimum geothermal closed loop flow rate. The third flow rate shown is optimum for geothermal closed loop and the suggested flow rate for boiler tower applications.

The manufacturer works continually to improve its products. As a result, the design and specifications of each product at the time of order may be changed without notice. Purchaser's approval of this data set signifies that the equipment is acceptable under the provisions of the job specification. Statements and other information contained herein are not express warranties and do not form the basis of any bargain between the parties, but are merely the manufacturer's opinion or commendation of its products. York and Affinity are registered trademarks of Johnson Controls, Inc., and are used with permission.

Contractor: _____ P.O.: _____

Engineer: _____

Project Name: _____ Unit Tag: _____

**Affinity Dual Capacity
Outdoor Split Series
2 - 6 Tons 60Hz**



Model 064 - Performance Data

064 - Dual Capacity High Speed

EWT °F	Flow gpm	WPD		HEATING - EAT 70°F						COOLING - EAT 80/67 °F						
		PSI	FT	Airflow cfm	HC MBtuh	Power kW	HE MBtuh	LAT °F	COP	Airflow cfm	TC MBtuh	SC MBtuh	S/T Ratio	Power kW	HR MBtuh	EER
20	8.0	1.9	4.3	Operation not recommended						Operation not recommended						
	12.0	4.2	9.7	Operation not recommended						Operation not recommended						
	16.0	6.7	15.4	1500	37.1	3.77	24.3	92.9	2.89	Operation not recommended						
30	8.0	1.8	4.2	Operation not recommended						Operation not recommended						
				Operation not recommended						Operation not recommended						
	12.0	4.1	9.5	1500	45.3	3.68	32.7	97.9	3.61	1500	56.2	34.2	0.61	2.49	64.7	22.5
	16.0	6.5	14.9	1800	46.3	3.92	32.9	98.6	3.46	1500	56.5	34.2	0.61	2.42	64.8	23.4
				1800	47.0	3.95	33.5	94.2	3.49	1800	57.9	37.4	0.65	2.54	66.6	22.8
40	8.0	1.8	4.0	Operation not recommended						Operation not recommended						
				Operation not recommended						Operation not recommended						
	12.0	4.0	9.2	1500	51.5	3.91	38.2	101.8	3.86	1500	60.4	37.7	0.62	2.75	69.8	22.0
	16.0	6.3	14.5	1800	52.7	4.07	38.8	97.1	3.79	1800	61.5	41.2	0.67	2.88	71.3	21.3
				1500	52.3	3.98	38.7	102.3	3.86	1500	60.8	37.7	0.62	2.67	69.9	22.8
50	8.0	1.7	3.9	1500	54.6	4.05	40.8	103.7	3.95	1500	63.9	40.5	0.63	2.97	74.0	21.5
				1800	55.8	4.18	41.5	98.7	3.91	1800	65.2	44.1	0.68	3.16	76.0	20.6
	12.0	3.8	8.9	1500	57.8	4.13	43.7	105.7	4.10	1500	64.5	40.9	0.63	2.91	74.5	22.2
				1800	58.9	4.23	44.5	100.3	4.08	1800	65.8	44.5	0.68	3.09	76.4	21.3
	16.0	6.1	14.0	1500	58.7	4.18	44.5	106.3	4.12	1500	65.2	41.4	0.63	2.86	75.0	22.8
1800				60.0	4.28	45.4	100.9	4.11	1800	66.5	44.9	0.68	3.04	76.9	21.9	
60	8.0	1.6	3.8	1500	60.7	4.29	46.0	107.5	4.15	1500	61.5	39.4	0.64	3.22	72.4	19.1
				1800	62.0	4.36	47.1	101.9	4.17	1800	63.0	42.8	0.68	3.42	74.7	18.4
	12.0	3.7	8.6	1500	63.5	4.36	48.6	109.2	4.27	1500	62.1	39.8	0.64	3.15	72.8	19.7
				1800	64.8	4.42	49.8	103.3	4.30	1800	63.7	43.2	0.68	3.35	75.1	19.0
	16.0	5.9	13.6	1500	64.8	4.41	49.8	110.0	4.31	1500	62.7	40.2	0.64	3.10	73.3	20.2
1800				66.3	4.46	51.1	104.1	4.36	1800	64.3	43.7	0.68	3.30	75.5	19.5	
70	8.0	1.6	3.7	1500	66.7	4.52	51.3	111.2	4.33	1500	59.0	38.3	0.65	3.46	70.8	17.0
				1800	68.4	4.54	52.9	105.2	4.42	1800	60.8	41.6	0.68	3.69	73.4	16.5
	12.0	3.6	8.3	1500	69.2	4.59	53.5	112.7	4.42	1500	59.6	38.6	0.65	3.39	71.2	17.6
				1800	70.7	4.60	55.1	106.4	4.51	1800	61.5	41.9	0.68	3.61	73.8	17.0
	16.0	5.7	13.1	1500	70.9	4.64	55.1	113.8	4.48	1500	60.2	39.0	0.65	3.34	71.6	18.0
1800				72.6	4.64	56.8	107.3	4.59	1800	62.1	42.4	0.68	3.55	74.2	17.5	
80	8.0	1.5	3.5	1500	71.5	4.72	55.4	114.2	4.44	1500	57.2	36.9	0.65	3.80	70.1	15.0
				1800	73.2	4.70	57.2	107.7	4.57	1800	59.3	40.1	0.68	4.05	73.1	14.6
	12.0	3.5	8.0	1500	73.2	4.78	56.9	115.2	4.49	1500	57.8	37.2	0.64	3.73	70.5	15.5
				1800	75.0	4.73	58.8	108.6	4.64	1800	59.9	40.4	0.68	3.96	73.4	15.1
	16.0	5.5	12.7	1500	75.5	4.84	59.0	116.6	4.57	1500	58.3	37.6	0.64	3.66	70.8	15.9
1800				77.4	4.78	61.0	109.8	4.74	1800	60.5	40.9	0.68	3.90	73.8	15.5	
90	8.0	1.5	3.4	1500	76.3	4.92	59.5	117.1	4.55	1500	55.3	35.5	0.64	4.14	69.4	13.4
				1800	78.2	4.85	61.6	110.2	4.73	1800	57.7	38.6	0.67	4.41	72.8	13.1
	12.0	3.4	7.7	1500	77.3	4.97	60.4	117.7	4.56	1500	55.9	35.8	0.64	4.06	69.8	13.8
				1800	79.3	4.87	62.7	110.8	4.77	1800	58.3	38.9	0.67	4.32	73.0	13.5
	16.0	5.3	12.2	1500	80.0	5.03	62.8	119.4	4.66	1500	57.8	37.1	0.64	4.11	71.8	14.1
1800				82.1	4.92	65.3	112.2	4.89	1800	58.9	39.3	0.67	4.25	73.4	13.9	
100	8.0	1.4	3.3	Operation not recommended						Operation not recommended						
	12.0	3.2	7.5	Operation not recommended						Operation not recommended						
				1500	52.3	34.6	0.66	4.53	67.7	11.5						
	1800	54.8	37.6	0.69	4.83	71.2	11.3									
16.0	5.1	11.8	1500	52.8	35.0	0.66	4.45	68.0	11.9							
			1800	55.3	38.0	0.69	4.75	71.5	11.6							
110	8.0	1.4	3.2	Operation not recommended						Operation not recommended						
	12.0	3.1	7.2	Operation not recommended						Operation not recommended						
				1500	48.6	33.4	0.69	5.01	65.7	9.7						
	1800	51.2	36.3	0.71	5.34	69.5	9.6									
16.0	4.9	11.4	1500	49.1	33.8	0.69	4.92	65.9	10.0							
			1800	51.7	36.7	0.71	5.25	69.6	9.8							
120	8.0	1.3	3.0	Operation not recommended						Operation not recommended						
	12.0	3.0	6.9	Operation not recommended						Operation not recommended						
				1500	46.8	31.0	0.66	5.55	65.7	8.4						
	1800	47.6	33.7	0.71	5.69	67.1	8.4									
16.0	4.7	10.9	1500	47.2	31.0	0.66	5.37	65.5	8.8							
			1800	48.2	33.7	0.70	5.54	67.1	8.7							

1/4/17

Multiple Flow Rates (for EWT) are shown in the table above. The lowest flow rate shown is used for geothermal open loop/well water systems with a minimum 50° F. The second flow rate shown is the minimum geothermal closed loop flow rate. The third flow rate shown is optimum for geothermal closed loop and the suggested flow rate for boiler tower applications.

The manufacturer works continually to improve its products. As a result, the design and specifications of each product at the time of order may be changed without notice. Purchaser's approval of this data set signifies that the equipment is acceptable under the provisions of the job specification. Statements and other information contained herein are not express warranties and do not form the basis of any bargain between the parties, but are merely the manufacturer's opinion or commendation of its products. York and Affinity are registered trademarks of Johnson Controls, Inc., and are used with permission.

Contractor: _____ P.O.: _____

Engineer: _____

Project Name: _____ Unit Tag: _____

**Affinity Dual Capacity
Outdoor Split Series
2 - 6 Tons 60Hz**



Model 072 - Performance Data

072 - Dual Capacity Low Speed

EWT °F	Flow gpm	WPD		HEATING - EAT 70°F						COOLING - EAT 80/67 °F						
		PSI	FT	Airflow cfm	HC MBtuh	Power kW	HE MBtuh	LAT °F	COP	Airflow cfm	TC MBtuh	SC MBtuh	S/T Ratio	Power kW	HR MBtuh	EER
20	10.0	2.5	5.7	Operation not recommended						Operation not recommended						
	13.0	4.1	9.5	Operation not recommended						Operation not recommended						
	16.0	5.7	13.2	1400	35.8	3.77	22.9	93.7	2.78	Operation not recommended						
				1600	36.2	3.71	23.5	90.9	2.86	Operation not recommended						
30	10.0	2.4	5.6	Operation not recommended						Operation not recommended						
	13.0	4.0	9.2	1400	38.8	3.84	25.7	95.6	2.96	1400	50.6	30.1	0.60	1.76	56.6	28.8
				1600	40.7	3.89	27.4	93.6	3.07	1600	51.4	32.9	0.64	1.85	57.7	27.8
	16.0	5.6	12.8	1400	41.9	3.95	28.4	97.7	3.11	1400	50.9	30.1	0.59	1.70	56.7	29.8
				1600	42.4	3.89	29.1	94.5	3.19	1600	52.1	32.9	0.63	1.79	58.2	29.1
40	10.0	2.3	5.4	Operation not recommended						Operation not recommended						
	13.0	3.9	8.9	1400	44.9	4.00	31.2	99.7	3.29	1400	54.4	33.4	0.61	1.98	61.2	27.5
				1600	46.8	4.01	33.1	97.1	3.42	1600	55.4	36.5	0.66	2.08	62.5	26.7
	16.0	5.4	12.5	1400	46.4	4.01	32.7	100.7	3.39	1400	54.8	33.4	0.61	1.92	61.4	28.5
				1600	48.5	4.03	34.8	98.1	3.53	1600	56.1	36.5	0.65	2.01	62.9	27.9
50	10.0	2.3	5.2	1400	50.1	4.12	36.1	103.2	3.57	1400	57.9	35.0	0.60	2.25	64.6	25.8
				1600	52.4	4.07	38.5	100.3	3.77	1600	59.7	39.7	0.66	2.36	66.8	25.2
	13.0	3.7	8.6	1400	50.9	4.16	36.7	103.7	3.59	1400	58.1	35.3	0.61	2.17	65.5	26.7
				1600	52.9	4.14	38.8	100.6	3.75	1600	59.9	40.1	0.67	2.29	67.3	26.2
	16.0	5.2	12.1	1400	52.4	4.18	38.1	104.6	3.67	1400	58.2	35.3	0.61	2.11	66.0	27.5
1600				54.6	4.16	40.4	101.6	3.85	1600	60.0	40.1	0.67	2.23	67.6	26.9	
60	10.0	2.2	5.1	1400	55.5	4.24	41.0	106.7	3.83	1400	55.2	34.3	0.62	2.60	63.7	21.2
				1600	57.8	4.16	43.7	103.5	4.08	1600	56.9	38.7	0.68	2.72	65.8	20.9
	13.0	3.6	8.4	1400	57.1	4.29	42.4	107.7	3.90	1400	55.4	34.6	0.62	2.52	64.0	22.0
				1600	59.3	4.21	44.9	104.3	4.13	1600	57.1	39.1	0.69	2.63	66.1	21.7
	16.0	5.1	11.7	1400	58.4	4.33	43.6	108.6	3.95	1400	55.7	34.7	0.62	2.47	64.4	22.5
1600				60.7	4.26	46.2	105.1	4.18	1600	57.4	39.2	0.68	2.58	66.2	22.3	
70	10.0	2.1	4.9	1400	60.9	4.37	46.0	110.3	4.08	1400	52.5	33.5	0.64	2.96	62.3	17.8
				1600	64.5	4.33	49.7	107.3	4.37	1600	54.0	37.7	0.70	3.07	64.1	17.6
	13.0	3.5	8.1	1400	63.2	4.41	48.1	111.8	4.19	1400	52.8	33.9	0.64	2.86	62.6	18.5
				1600	65.6	4.29	51.0	108.0	4.49	1600	54.3	38.2	0.70	2.98	64.5	18.3
	16.0	4.9	11.3	1400	64.3	4.48	49.0	112.5	4.21	1400	53.1	34.1	0.64	2.82	62.8	18.8
1600				66.8	4.35	52.0	108.7	4.50	1600	54.8	38.3	0.70	2.92	64.8	18.8	
80	10.0	2.0	4.7	1400	65.4	4.49	50.1	113.3	4.27	1400	48.2	32.1	0.67	3.35	59.7	14.4
				1600	67.8	4.33	53.0	109.2	4.59	1600	51.2	35.9	0.70	3.45	63.0	14.9
	13.0	3.4	7.8	1400	68.9	4.55	53.3	115.5	4.44	1400	50.1	32.5	0.65	3.27	61.3	15.3
				1600	71.3	4.36	56.4	111.3	4.79	1600	51.6	36.3	0.70	3.36	63.1	15.4
	16.0	4.7	10.9	1400	69.7	4.61	53.9	116.1	4.43	1400	50.5	32.7	0.65	3.22	61.5	15.7
1600				72.1	4.44	56.9	111.7	4.76	1600	50.5	36.6	0.72	3.31	61.8	15.3	
90	10.0	2.0	4.6	1400	70.0	4.62	54.2	116.3	4.44	1400	43.9	30.7	0.70	3.75	56.7	11.7
				1600	72.3	4.42	57.2	111.8	4.79	1600	45.3	34.1	0.75	3.83	58.3	11.8
	13.0	3.3	7.5	1400	74.5	4.68	58.5	119.3	4.67	1400	44.4	31.0	0.70	3.67	57.7	12.1
				1600	77.0	4.44	61.8	114.6	5.08	1600	45.7	34.5	0.75	3.75	58.5	12.2
	16.0	4.6	10.5	1400	75.0	4.74	58.8	119.6	4.63	1400	46.8	33.2	0.71	3.73	59.5	12.5
1600				77.3	4.53	61.8	114.7	5.00	1600	46.2	34.8	0.75	3.69	58.8	12.5	
100	10.0	1.9	4.4	Operation not recommended						Operation not recommended						
	13.0	3.1	7.3	1400	41.9	29.6	0.71	4.30	56.5	9.7						
				1600	43.2	32.7	0.76	4.35	58.1	9.9						
	16.0	4.4	10.1	1400	42.4	29.9	0.70	4.23	56.9	10.0						
				1600	43.7	33.1	0.76	4.29	58.3	10.2						
110	10.0	1.8	4.2	Operation not recommended						Operation not recommended						
	13.0	3.0	7.0	Operation not recommended						1400	39.4	28.1	0.71	4.92	56.2	8.0
				1600	40.7	31.0	0.76	4.95	57.6	8.2						
	16.0	4.2	9.8	Operation not recommended						1400	40.0	28.5	0.71	4.86	56.6	8.2
				1600	41.2	31.4	0.76	4.88	57.9	8.4						
120	10.0	1.8	4.1	Operation not recommended						Operation not recommended						
	13.0	2.9	6.7	Operation not recommended						1400	37.5	28.1	0.75	5.49	56.2	6.8
				1600	38.1	30.5	0.80	5.63	57.4	6.8						
	16.0	4.1	9.4	Operation not recommended						1400	37.8	28.1	0.74	5.31	55.9	7.1
				1600	38.6	30.5	0.79	5.48	57.3	7.0						

1/4/17

Multiple Flow Rates (for EWT) are shown in the table above. The lowest flow rate shown is used for geothermal open loop/well water systems with a minimum 50° F. The second flow rate shown is the minimum geothermal closed loop flow rate. The third flow rate shown is optimum for geothermal closed loop and the suggested flow rate for boiler tower applications.

The manufacturer works continually to improve its products. As a result, the design and specifications of each product at the time of order may be changed without notice. Purchaser's approval of this data set signifies that the equipment is acceptable under the provisions of the job specification. Statements and other information contained herein are not express warranties and do not form the basis of any bargain between the parties, but are merely the manufacturer's opinion or commendation of its products. York and Affinity are registered trademarks of Johnson Controls, Inc., and are used with permission.

Contractor: _____ P.O.: _____

Engineer: _____

Project Name: _____ Unit Tag: _____

**Affinity Dual Capacity
Outdoor Split Series
2 - 6 Tons 60Hz**



Model 072 - Performance Data

072 - Dual Capacity High Speed

EWT °F	Flow gpm	WPD		HEATING - EAT 70°F						COOLING - EAT 80/67 °F						
		PSI	FT	Airflow cfm	HC MBtuh	Power kW	HE MBtuh	LAT °F	COP	Airflow cfm	TC MBtuh	SC MBtuh	S/T Ratio	Power kW	HR MBtuh	EER
20	12.0	3.4	7.9	Operation not recommended						Operation not recommended						
	15.0	5.1	11.9	Operation not recommended						Operation not recommended						
	18.0	7.0	16.1	1800	36.7	4.41	21.6	88.9	2.44	Operation not recommended						
				2000	37.0	4.43	21.9	87.1	2.45	Operation not recommended						
30	12.0	3.3	7.7	Operation not recommended						Operation not recommended						
	15.0	5.0	11.6	1800	54.7	4.80	38.3	98.1	3.34	1800	62.7	37.3	0.60	2.87	72.5	21.9
				2000	56.6	5.11	39.2	96.2	3.25	2000	63.8	40.8	0.64	3.02	74.1	21.1
	18.0	6.8	15.6	1800	56.7	5.14	39.2	99.2	3.23	1800	63.1	37.3	0.59	2.78	72.6	22.7
				2000	57.2	5.16	39.6	96.5	3.25	2000	64.6	40.8	0.63	2.92	74.6	22.1
	40	12.0	3.2	7.5	Operation not recommended						Operation not recommended					
15.0		4.8	11.2	1800	61.8	5.07	44.5	101.8	3.57	1800	67.5	41.4	0.61	3.17	78.3	21.3
				2000	63.9	5.30	45.8	99.6	3.53	2000	68.7	45.2	0.66	3.32	80.1	20.7
18.0		6.6	15.2	1800	62.6	5.12	45.2	102.2	3.58	1800	68.0	41.4	0.61	3.07	78.5	22.1
				2000	64.8	5.36	46.5	100.0	3.55	2000	69.5	45.2	0.65	3.22	80.5	21.6
50		12.0	3.1	7.2	1800	65.2	5.22	47.4	103.5	3.66	1800	71.5	44.7	0.63	3.43	83.2
	2000				67.4	5.41	48.9	101.2	3.65	2000	73.0	48.6	0.67	3.64	85.4	20.1
	15.0	4.7	10.9	1800	68.9	5.32	50.7	105.4	3.79	1800	72.2	45.2	0.63	3.35	83.7	21.5
				2000	71.1	5.50	52.4	102.9	3.79	2000	73.6	49.1	0.67	3.57	85.8	20.7
	18.0	6.4	14.7	1800	70.1	5.39	51.7	106.1	3.81	1800	73.0	46.1	0.63	3.30	84.2	22.1
				2000	72.4	5.55	53.5	103.5	3.82	2000	74.4	49.6	0.67	3.51	86.4	21.2
60	12.0	3.0	7.0	1800	74.1	5.46	55.5	108.1	3.98	1800	67.7	43.8	0.65	3.74	80.4	18.1
				2000	76.5	5.57	57.5	105.4	4.03	2000	69.1	47.3	0.68	3.98	82.6	17.4
	15.0	4.5	10.5	1800	77.3	5.55	58.4	109.8	4.08	1800	68.3	44.2	0.65	3.67	80.8	18.6
				2000	79.9	5.64	60.6	107.0	4.15	2000	69.7	47.8	0.69	3.89	83.0	17.9
	18.0	6.2	14.2	1800	79.1	5.62	59.9	110.7	4.13	1800	69.1	44.9	0.65	3.60	81.4	19.2
				2000	81.7	5.70	62.3	107.8	4.20	2000	70.5	48.3	0.69	3.84	83.5	18.4
70	12.0	2.9	6.8	1800	82.9	5.68	63.5	112.7	4.28	1800	63.8	42.8	0.67	4.06	77.7	15.7
				2000	84.7	5.88	64.6	109.2	4.22	2000	65.2	46.0	0.71	4.32	79.9	15.1
	15.0	4.4	10.2	1800	85.9	5.77	66.2	114.2	4.36	1800	64.5	43.2	0.67	3.98	78.0	16.2
				2000	88.6	5.78	68.8	111.0	4.49	2000	65.8	46.5	0.71	4.22	80.2	15.6
	18.0	6.0	13.8	1800	88.1	5.85	68.1	115.3	4.42	1800	65.2	43.7	0.67	3.90	78.5	16.7
				2000	91.0	5.85	71.0	112.1	4.56	2000	66.5	47.0	0.71	4.16	80.7	16.0
80	12.0	2.8	6.5	1800	87.8	6.00	67.3	115.2	4.29	1800	60.6	40.9	0.67	4.52	76.0	13.4
				2000	91.1	6.03	70.5	112.2	4.43	2000	61.9	44.2	0.71	4.80	78.3	12.9
	15.0	4.3	9.8	1800	90.3	6.15	69.3	116.5	4.30	1800	61.2	41.3	0.67	4.42	76.3	13.8
				2000	93.2	6.07	72.5	113.1	4.50	2000	62.5	44.6	0.71	4.71	78.5	13.3
	18.0	5.7	13.3	1800	93.1	6.23	71.8	117.9	4.38	1800	61.9	41.9	0.68	4.35	76.7	14.2
				2000	96.1	6.14	75.2	114.5	4.59	2000	63.2	45.1	0.71	4.63	78.9	13.6
90	12.0	2.7	6.3	1800	93.5	6.46	71.4	118.1	4.24	1800	57.4	38.9	0.68	4.97	74.4	11.5
				2000	96.6	6.33	75.0	114.7	4.47	2000	58.6	42.3	0.72	5.29	76.7	11.1
	15.0	4.1	9.5	1800	94.8	6.53	72.5	118.8	4.25	1800	58.0	39.3	0.68	4.87	74.6	11.9
				2000	97.9	6.36	76.2	115.3	4.51	2000	59.2	42.7	0.72	5.19	76.9	11.4
	18.0	5.5	12.8	1800	98.0	6.62	75.5	120.4	4.34	1800	59.8	41.5	0.69	4.98	76.8	12.0
				2000	101.3	6.43	79.4	116.9	4.62	2000	59.8	43.1	0.72	5.10	77.2	11.7
100	12.0	2.6	6.1	Operation not recommended						Operation not recommended						
	15.0	4.0	9.1	1800	54.4	37.6	0.69	5.45	73.0	10.0	Operation not recommended					
				2000	55.5	40.7	0.73	5.80	75.3	9.6	Operation not recommended					
	18.0	5.3	12.3	1800	55.0	38.2	0.69	5.36	73.3	10.3	Operation not recommended					
2000				56.2	41.1	0.73	5.70	75.6	9.9	Operation not recommended						
110	12.0	2.5	5.8	Operation not recommended						Operation not recommended						
	15.0	3.8	8.8	1800	50.9	36.0	0.71	6.03	71.4	8.4	Operation not recommended					
				2000	51.9	38.7	0.75	6.41	73.8	8.1	Operation not recommended					
	18.0	5.1	11.9	1800	51.4	36.4	0.71	5.92	71.7	8.7	Operation not recommended					
2000				52.5	39.1	0.74	6.30	74.0	8.3	Operation not recommended						
120	12.0	2.4	5.6	Operation not recommended						Operation not recommended						
	15.0	3.7	8.4	1800	48.5	36.8	0.76	6.95	72.3	7.0	Operation not recommended					
				2000	49.4	39.9	0.81	7.13	73.8	6.9	Operation not recommended					
	18.0	4.9	11.4	1800	49.0	36.8	0.75	6.73	71.9	7.3	Operation not recommended					
2000				50.0	39.9	0.80	6.94	73.7	7.2	Operation not recommended						

1/4/17

Multiple Flow Rates (for EWT) are shown in the table above. The lowest flow rate shown is used for geothermal open loop/well water systems with a minimum 50° F. The second flow rate shown is the minimum geothermal closed loop flow rate. The third flow rate shown is optimum for geothermal closed loop and the suggested flow rate for boiler tower applications.

The manufacturer works continually to improve its products. As a result, the design and specifications of each product at the time of order may be changed without notice. Purchaser's approval of this data set signifies that the equipment is acceptable under the provisions of the job specification. Statements and other information contained herein are not express warranties and do not form the basis of any bargain between the parties, but are merely the manufacturer's opinion or commendation of its products. York and Affinity are registered trademarks of Johnson Controls, Inc., and are used with permission.

Contractor: _____ P.O.: _____
 Engineer: _____
 Project Name: _____ Unit Tag: _____

**Affinity Dual Capacity
 Outdoor Split Series
 2 - 6 Tons 60Hz**



Wiring Schematics cont.

Dual Capacity Split - 208-230/60/1 cont.

Aurora LED Flash Codes		
Slow Flash	1 second on and 1 second off	
Fast Flash	100 milliseconds on and 100 milliseconds off	
Flash Code	100 milliseconds on and 400 milliseconds off with a 2 second pause before repeating	
Random Start Delay (Alternating Colors)		Configuration LED (LED2, Yellow)
Status LED (LED1, Green)	Fast Flash	No Software Override
Configuration LED (LED2, Yellow)	Fast Flash	DIP Switch Override
Fault LED (LED3, Red)	Fast Flash	Slow Flash
Fault LED (LED1, Red)		Status LED (LED3, Green)
Normal Mode	OFF	Normal Mode
Input Fault Lockout	Flash Code 1	Control is Non-Functional
High Pressure Lockout	Flash Code 2	Test Mode
Low Pressure Lockout	Flash Code 3	Lockout Active
Future Use	Flash Code 4	Dehumidification Mode
Freeze Detection - FP1	Flash Code 5	Future Use
Reserved	Flash Code 6	Future Use
Condensate Overflow Lockout	Flash Code 7	Load Shed
Over/Under Voltage Shutdown	Flash Code 8	ESD
Future Use	Flash Code 9	Future Use
Future Use	Flash Code 10	Future Use
FP1 and FP2 Sensor Error	Flash Code 11	Flash Code 7

Aurora Timing Events		
Event	Normal Mode	Test Mode
Random Start Delay	5 to 80 seconds	1 second
Compressor On Delay	5 seconds	< 1 second
Compressor Minimum On Time	2 minutes	5 seconds
Compressor Short Cycle Delay	4 minutes	15 seconds
Blower Off Delay	30 seconds	2 seconds
Fault Recognition Delay - High Pressure	Less than 1 second	Less than 1 second
Start-Up Bypass - Low Pressure	2 minutes	30 seconds
Fault Recognition Delay - Low Pressure	30 seconds	30 seconds
Start-Up Bypass - Low Water Coil Limit	2 minutes	30 seconds
Fault Recognition Delay - Low Water Coil Limit	30 seconds	30 seconds
Fault Recognition Delay - Condensate Overflow	30 seconds	30 seconds
Thermostat Call Recognition Time	2 seconds	2 seconds
Water Valve Slow Open Delay	90 seconds	90 seconds

ABC SW2 Accessory Relay		
DESCRIPTION	SW2-4	SW2-5
Cycle with Blower	ON	ON
Cycle with Compressor	OFF	OFF
Water Valve Slow Opening	ON	OFF
Cycle with Comm. T-stat Hum Cmd	OFF	ON

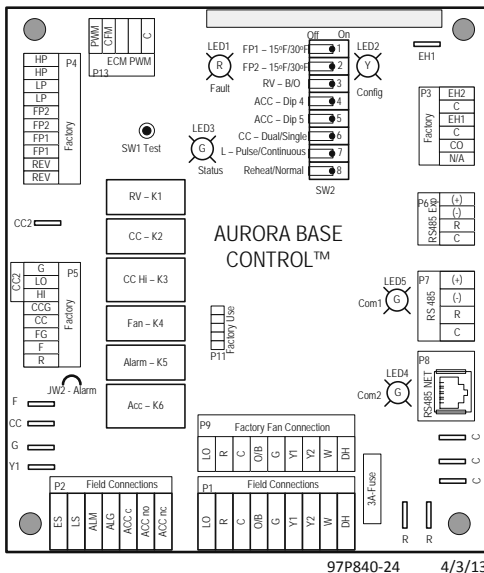
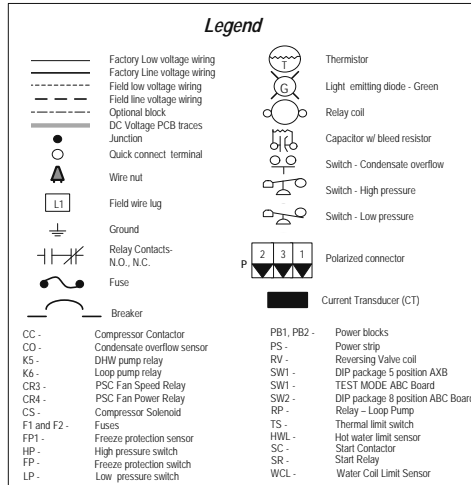

Notes

1 - Flow Center may be either factory or field installed.
 2 - Field installed SPST relay required for dual fuel applications.

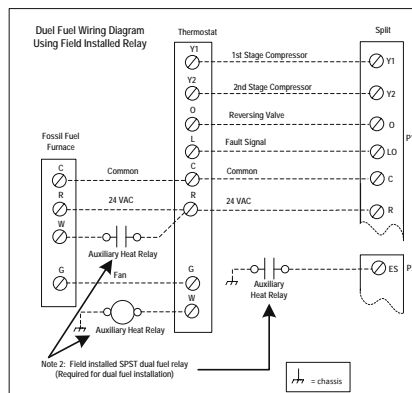

The manufacturer works continually to improve its products. As a result, the design and specifications of each product at the time of order may be changed without notice. Purchaser's approval of this data set signifies that the equipment is acceptable under the provisions of the job specification. Statements and other information contained herein are not express warranties and do not form the basis of any bargain between the parties, but are merely the manufacturer's opinion or commendation of its products. York and Affinity are registered trademarks of Johnson Controls, Inc., and are used with permission.

Contractor: _____ P.O.: _____

Engineer: _____

Project Name: _____ Unit Tag: _____

**Affinity Dual Capacity
Outdoor Split Series
2 - 6 Tons 60Hz**



Wiring Schematics cont.

Dual Capacity Split with IntelliStart - 208-230/60/1

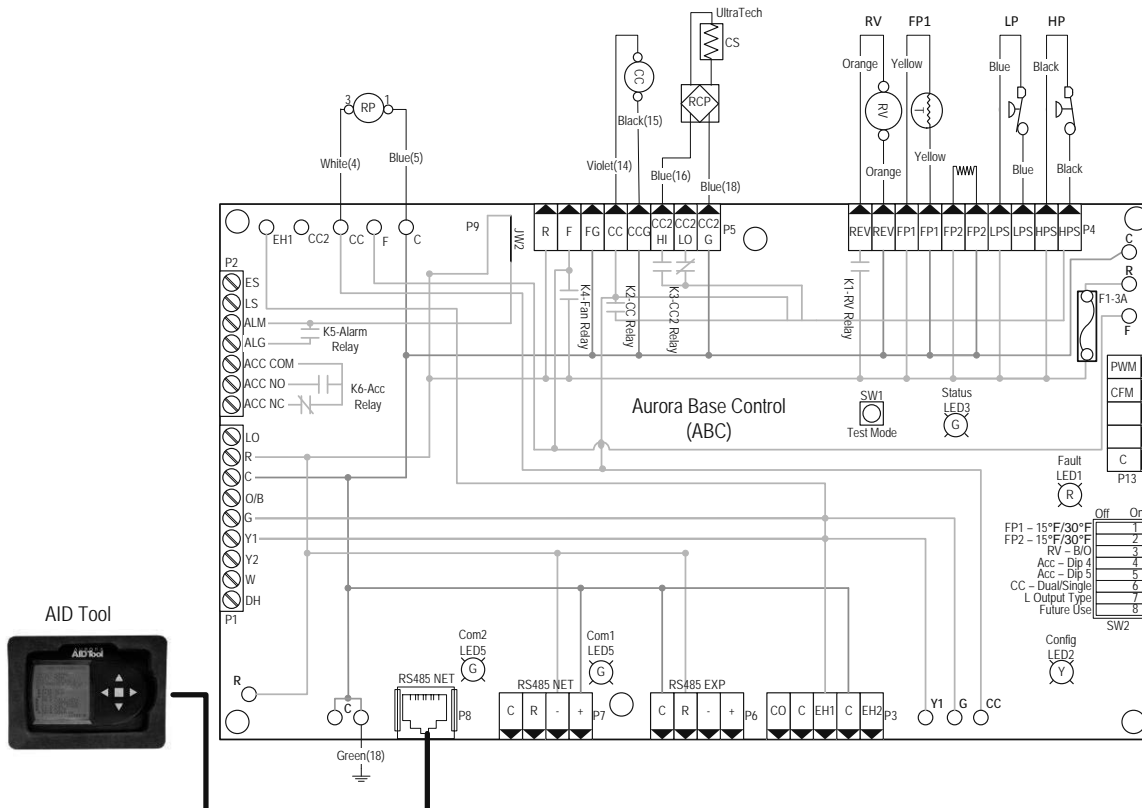
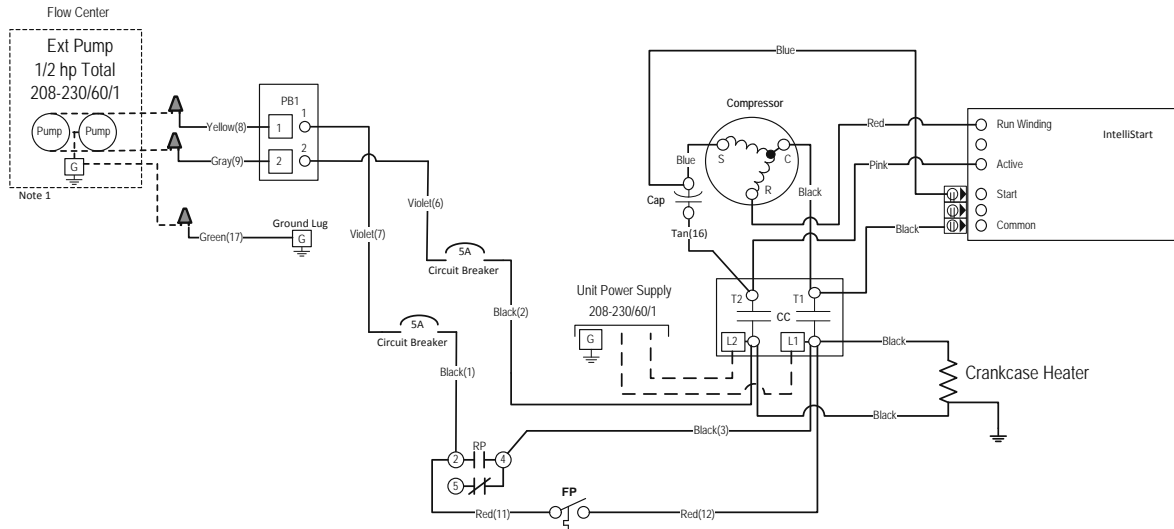

The manufacturer works continually to improve its products. As a result, the design and specifications of each product at the time of order may be changed without notice. Purchaser's approval of this data set signifies that the equipment is acceptable under the provisions of the job specification. Statements and other information contained herein are not express warranties and do not form the basis of any bargain between the parties, but are merely the manufacturer's opinion or commendation of its products. York and Affinity are registered trademarks of Johnson Controls, Inc., and are used with permission.



Contractor: _____ P.O.: _____

Engineer: _____

Project Name: _____ Unit Tag: _____

Wiring Schematics cont.

Dual Capacity Split with IntelliStart - 208-230/60/1 cont.

Aurora LED Flash Codes			
Slow Flash	1 second on and 1 second off		
Fast Flash	100 milliseconds on and 100 milliseconds off		
Flash Code	100 milliseconds on and 400 milliseconds off with a 2 second pause before repeating		
Random Start Delay (Alternating Colors)		Configuration LED (LED2 - Yellow)	
Status LED (LED1 - Green)	Fast Flash	No Software Override	OFF
Configuration LED (LED2 - Yellow)	Fast Flash	DIP Switch Override	Slow Flash
Fault LED (LED3 - Red)	Fast Flash		
Fault LED (LED1 - Red)		Status LED (LED3 - Green)	
Normal Mode	OFF	Normal Mode	ON
Input Fault Lockout	Flash Code 1	Control is Non-Functional	OFF
High Pressure Lockout	Flash Code 2	Test Mode	Slow Flash
Low Pressure Lockout	Flash Code 3	Lockout Active	Fast Flash
Future Use	Flash Code 4	Dehumidification Mode	Flash Code 2
Freeze Detection - FP1	Flash Code 5	Future Use	Flash Code 3
Reserved	Flash Code 6	Future Use	Flash Code 4
Condensate Overflow Lockout	Flash Code 7	Load Shed	Flash Code 5
Over/Under Voltage Shutdown	Flash Code 8	ESD	Flash Code 6
Future Use	Flash Code 9	Future Use	Flash Code 7
Future Use	Flash Code 10		
FP1 and FP2 Sensor Error	Flash Code 11		

Aurora Timing Events		
Event	Normal Mode	Test Mode
Random Start Delay	5 to 80 seconds	1 second
Compressor On Delay	5 seconds	< 1 second
Compressor Minimum On Time	2 minutes	5 seconds
Compressor Short Cycle Delay	4 minutes	15 seconds
Blower Off Delay	30 seconds	2 seconds
Fault Recognition Delay - High Pressure	Less than 1 second	Less than 1 second
Start-Up Bypass - Low Pressure	2 minutes	30 seconds
Fault Recognition Delay - Low Pressure	30 seconds	30 seconds
Start-Up Bypass - Low Water Coil Limit	2 minutes	30 seconds
Fault Recognition Delay - Low Water Coil Limit	30 seconds	30 seconds
Fault Recognition Delay - Condensate Overflow	30 seconds	30 seconds
Thermostat Call Recognition Time	2 seconds	2 seconds
Water Valve Slow Open Delay	90 seconds	90 seconds

ABC SW2 Accessory Relay		
DESCRIPTION	SW2-4	SW2-5
Cycle with Blower	ON	ON
Cycle with Compressor	OFF	OFF
Water Valve Slow Opening	ON	OFF
Cycle with Comm. T-stat Hum Cmd	OFF	ON

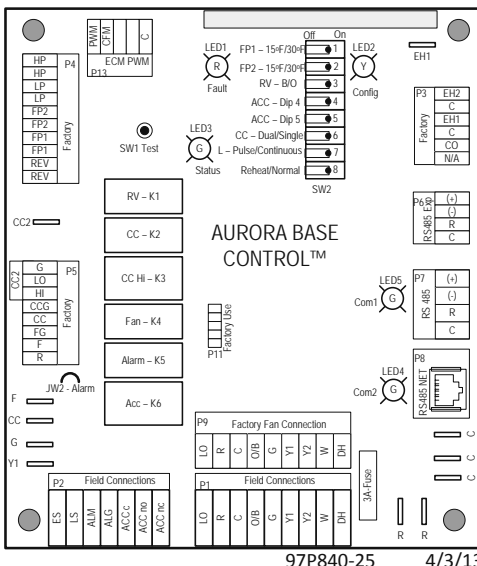
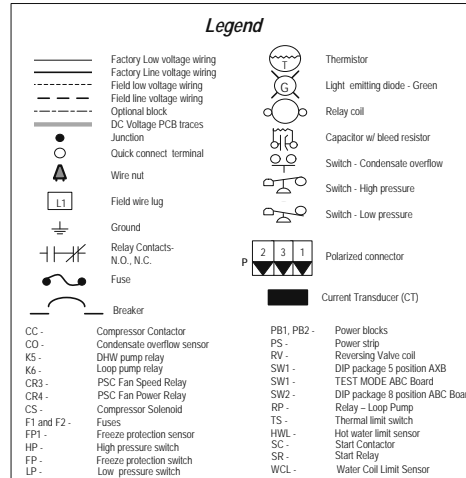

Notes

1 - Flow Center may be either factory or field installed.
2 - Field installed SPST relay required for dual fuel applications.

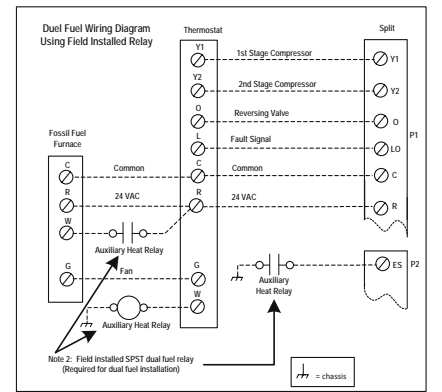

The manufacturer works continually to improve its products. As a result, the design and specifications of each product at the time of order may be changed without notice. Purchaser's approval of this data set signifies that the equipment is acceptable under the provisions of the job specification. Statements and other information contained herein are not express warranties and do not form the basis of any bargain between the parties, but are merely the manufacturer's opinion or commendation of its products. York and Affinity are registered trademarks of Johnson Controls, Inc., and are used with permission.

Contractor: _____ P.O.: _____

Engineer: _____

Project Name: _____ Unit Tag: _____

Affinity Dual Capacity Outdoor Split Series 2 - 6 Tons 60Hz



Wiring Schematics cont.

Dual Capacity Split with Aurora Advanced - 208-230/60/1

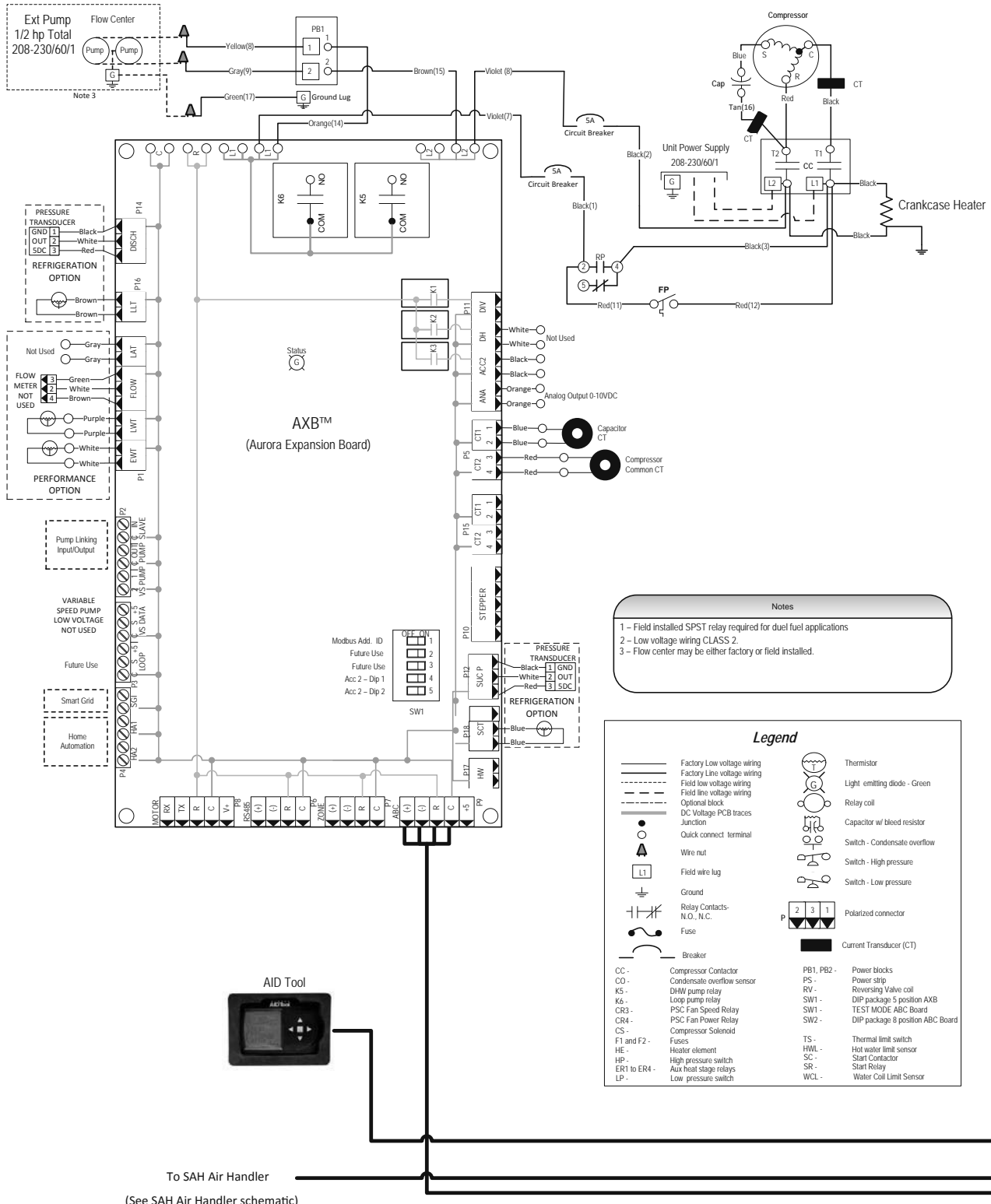

- Notes**
- 1 - Field installed SPST relay required for dual fuel applications
 - 2 - Low voltage wiring CLASS 2.
 - 3 - Flow center may be either factory or field installed.

Legend

	Factory low voltage wiring		Thermistor
	Factory line voltage wiring		Light emitting diode - Green
	Field low voltage wiring		Relay coil
	Field line voltage wiring		Capacitor w/ bleed resistor
	Optional block		Switch - Condensate overflow
	DC Voltage PCB traces		Switch - High pressure
	Junction		Switch - Low pressure
	Quick connect terminal		Polarized connector
	Wire nut		Current Transducer (CT)
	Field wire lug		
	Ground		
	Relay Contacts - N.O., N.C.		
	Fuse		
	Breaker		

CC - Compressor Contactor
 CO - Condensate overflow sensor
 K5 - DHW pump relay
 K6 - Loop pump relay
 CR3 - PSC Fan Speed Relay
 CR4 - PSC Fan Power Relay
 CS - Compressor Solenoid
 F1 and F2 - Fuses
 HE - Heater element
 HP - High pressure switch
 ER1 to ER4 - Aux heat stage relays
 LP - Low pressure switch

PB1, PB2 - Power blocks
 PS - Power strip
 RV - Reversing Valve coil
 SW1 - DIP package 5 position AXB
 SW1 - TEST MODE ABC Board
 SW2 - DIP package 8 position ABC Board

TS - Thermal limit switch
 HWL - Hot water limit sensor
 SC - Start Contactor
 SR - Start Relay
 WCL - Water Coil Limit Sensor

The manufacturer works continually to improve its products. As a result, the design and specifications of each product at the time of order may be changed without notice. Purchaser's approval of this data set signifies that the equipment is acceptable under the provisions of the job specification. Statements and other information contained herein are not express warranties and do not form the basis of any bargain between the parties, but are merely the manufacturer's opinion or commendation of its products. York and Affinity are registered trademarks of Johnson Controls, Inc., and are used with permission.

Contractor: _____ P.O.: _____

Engineer: _____

Project Name: _____ Unit Tag: _____

**Affinity Dual Capacity
Outdoor Split Series
2 - 6 Tons 60Hz**



Wiring Schematics cont.

Dual Capacity Split with Aurora Advanced - 208-230/60/1 cont.

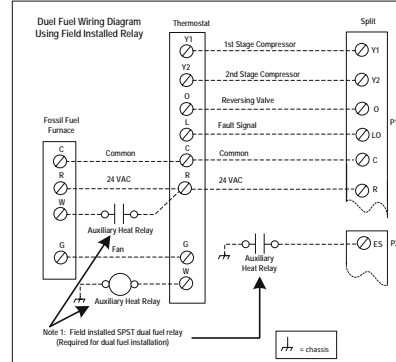
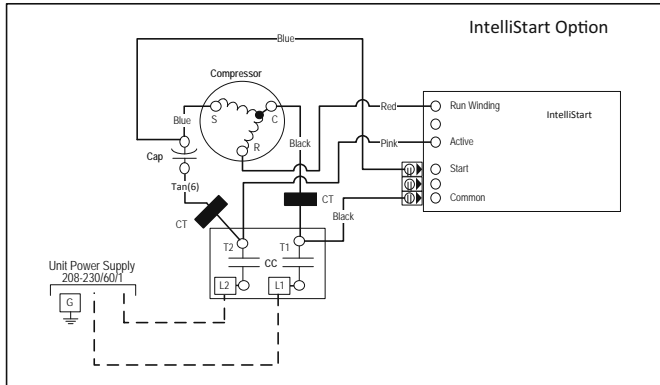

Aurora LED Flash Codes			
Slow Flash	1 second on and 1 second off		
Fast Flash	100 milliseconds on and 100 milliseconds off		
Flash Code	100 milliseconds on and 400 milliseconds off with a 2 second pause before repeating		
Random Start Delay (Alternating Colors)		Configuration LED (LED2, Yellow)	
Status LED (LED1, Green)	Fast Flash	No Software Override	OFF
Configuration LED (LED2, Yellow)	Fast Flash	DIP Switch Override	Slow Flash
Fault LED (LED3, Red)	Fast Flash		
Fault LED (LED1, Red)		Status LED (LED3, Green)	
Normal Mode	OFF	Normal Mode	ON
Input Fault Lockout	Flash Code 1	Control is Non-Functional	OFF
High Pressure Lockout	Flash Code 2	Test Mode	Slow Flash
Low Pressure Lockout	Flash Code 3	Lockout Active	Fast Flash
Future Use	Flash Code 4	Dehumidification Mode	Flash Code 2
Freeze Detection - FP1	Flash Code 5	Future Use	Flash Code 3
Reserved	Flash Code 6	Future Use	Flash Code 4
Condensate Overflow Lockout	Flash Code 7	Load Shed	Flash Code 5
Over/Under Voltage Shutdown	Flash Code 8	ESD	Flash Code 6
Future Use	Flash Code 9	Future Use	Flash Code 7
Future Use	Flash Code 10		
FP1 and FP2 Sensor Error	Flash Code 11		

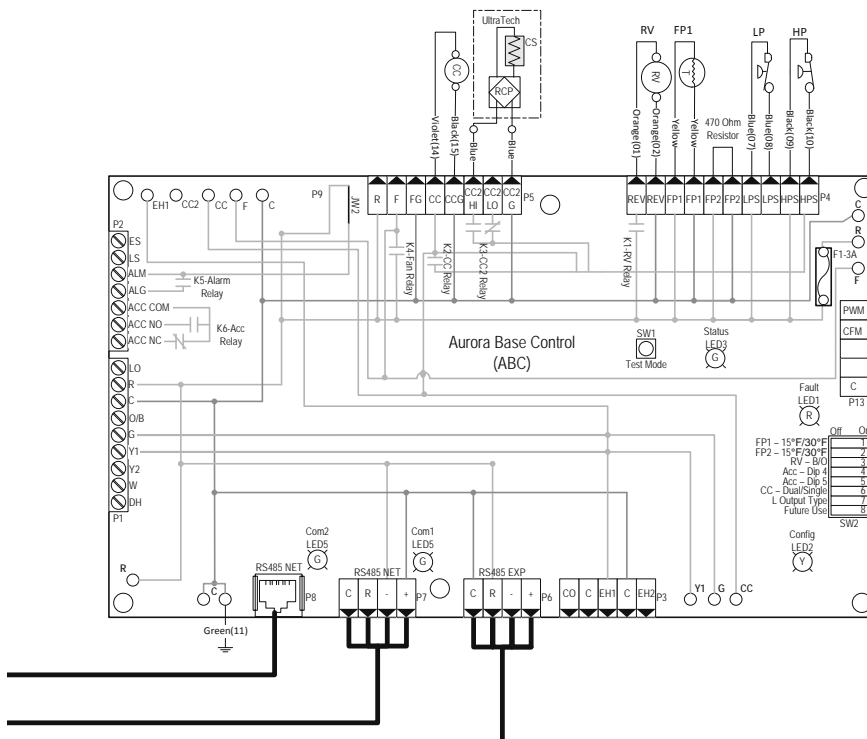

The manufacturer works continually to improve its products. As a result, the design and specifications of each product at the time of order may be changed without notice. Purchaser's approval of this data set signifies that the equipment is acceptable under the provisions of the job specification. Statements and other information contained herein are not express warranties and do not form the basis of any bargain between the parties, but are merely the manufacturer's opinion or commendation of its products. York and Affinity are registered trademarks of Johnson Controls, Inc., and are used with permission.



Contractor: _____ P.O.: _____

Engineer: _____

Project Name: _____ Unit Tag: _____

Engineering Guide Specifications

General

Furnish and install geothermal Water Source Heat Pumps, as indicated on the plans. The geothermal heating/cooling units shall be reverse cycle split system configuration designed for use with DX heating and cooling coils. Units shall be AHRI/ISO 13256-1 certified and listed by a nationally recognized safety-testing laboratory or agency, such as ETL Testing Laboratory. Each unit shall be computer run-tested at the factory with conditioned water and operation verified to catalog data. Each unit shall be mounted on a pallet and shipped in a corrugated box or stretch-wrapped. The units shall be designed to operate with entering liquid temperature between 20°F and 120°F [-6.7°C and 48.9°C].

Casing and Cabinet

The cabinet shall be fabricated from heavy-gauge galvanized steel and finished with corrosion-resistant powder coating. This corrosion protection system shall meet the stringent 1000 hour salt spray test per ASTM B117. The interior shall be insulated with 1/2-inch thick, multi-density, cleanable aluminum foil coated glass fiber with edges sealed or tucked under flanges. Standard cabinet panel insulation must meet NFPA 90A requirements, air erosion and mold growth limits of UL-181, stringent fungal resistance test per ASTM-C1071 and ASTM G21, and shall meet zero level bacteria growth per ASTM G22. Unit insulation must meet these stringent requirements or unit(s) will not be accepted.

Refrigerant Circuit

All units shall contain a sealed refrigerant circuit including a hermetic motor-compressor, thermostatic expansion valve, reversing valve, coaxial tube water-to-refrigerant heat exchanger, compressor discharge muffler, accumulator, and service ports.

Compressors shall be high-efficiency scroll single speed or dual capacity type designed for heat pump duty and mounted on rubber vibration isolators. Compressor motors shall be single-phase PSC with overload protection.

The coaxial water-to-refrigerant heat exchanger shall be designed for low water pressure drop and constructed of a convoluted copper (cupronickel option) inner tube and a steel outer tube. Refrigerant to water heat exchangers shall be of copper inner water tube and steel refrigerant outer tube design, rated to withstand 600 psig (4135 kPa) working refrigerant pressure and 450 psig (3101 kPa) working water pressure. The thermostatic expansion valve shall provide proper superheat over the entire liquid temperature range with minimal "hunting."

All units shall have the source coaxial tube refrigerant-to-water heat exchanger coated with ThermaShield. Refrigerant suction lines shall be insulated to prevent condensation at low liquid temperatures.

Electrical

A control box shall be located within the unit compressor compartment and shall contain a 2 pole compressor contactor, circuit breakers for protecting loop pumps, terminal block for thermostat wiring, and solid-state controller for complete unit operation. Electromechanical operation WILL NOT be accepted. Units shall be name-plated for use with time delay fuses or HACR circuit breakers. Unit controls shall be 24 volt and provide heating or cooling as required by the remote thermostat/sensor. An Aurora, a microprocessor-based controller, interfaces with a multi-stage electronic thermostat to monitor and control unit operation shall be provided. The control shall provide operational sequencing, high and low pressure switch monitoring, freeze detection, lockout mode control, hot water and loop pump control, LED status and fault indicators, fault memory, field selectable options, and accessory output. The Lockout signal output shall have a pulsed option so that DDC systems can read specific lockout conditions from the control.

A detachable terminal block with screw terminals will be provided for field control wiring. All units shall have knockouts for entrance of low and line voltage wiring. The control box shall be harness plug wired for easy removal.

An optional Aurora Interface Diagnostic (AID) Tool shall communicate with the Aurora control allowing quick and easy access to setup, monitoring, and troubleshooting of any Aurora control. The device shall include the features of fault description and history, manual operation capability, sensor readings, timings, and other diagnostic tools.

Optional IntelliStart® (compressor Soft Starter) shall be factory installed for use in applications that require low starting amps, reduced compressor start-up noise, off-grid, and improved start-up behavior. IntelliStart shall reduce normal starting current by 60% on 208/60/1 units.

Piping

Supply and return water connections shall be 1 in. [25.4 mm] GeoLink swivel fittings, which provide a union and eliminate the need for pipe wrenches and sealants when making field connections. All water piping shall be insulated to prevent condensation at low liquid temperatures.

The manufacturer works continually to improve its products. As a result, the design and specifications of each product at the time of order may be changed without notice. Purchaser's approval of this data set signifies that the equipment is acceptable under the provisions of the job specification. Statements and other information contained herein are not express warranties and do not form the basis of any bargain between the parties, but are merely the manufacturer's opinion or commendation of its products. York and Affinity are registered trademarks of Johnson Controls, Inc., and are used with permission.



Contractor: _____ P.O.: _____

Engineer: _____

Project Name: _____ Unit Tag: _____

Engineering Guide Specifications cont.

Options and Accessories

Cupronickel Heat Exchanger

An optional cupronickel water-to-refrigerant heat exchanger shall be provided.

Thermostat (field-installed)

A multi-stage auto-changeover electronic digital thermostat shall be provided. The thermostat shall offer three heating and two cooling stages with precise temperature control. An OFF-HEAT-AUTO-COOL-EMERG system switch, OFF-AUTO blower switch, and indicating LEDs shall be provided. The thermostat shall display in °F or °C. The thermostat shall be a traditional 24 VAC type.

Flow Center (field-installed)

A self-contained module shall provide all liquid flow, fill and connection requirements for ground source closed loop systems up to 20 gpm. The pumps shall be wired to a power block located in the nearest unit. The heat pump units shall contain low voltage pump slaving control so that two units may share one flow center.

Internally Mounted GeoLink Flow Center

A self-contained module shall provide all liquid flow, fill and connection requirements for ground source closed loop systems up to 20 gpm. The pumps shall be wired to a power block located in the nearest unit.

Contractor: _____ P.O.: _____

Engineer: _____

Project Name: _____ Unit Tag: _____

**Affinity Dual Capacity
Outdoor Split Series
2 - 6 Tons 60Hz**



Revision Guide

Pages:	Description:	Date:	By:
All	First Published	03 Sept 2013	DS
2	Updated Nomenclature to show FC2-GL Flow Center Option	16 June 2014	MA
Misc.	Updated for new Air Handler	10 Apr 2017	JM

The manufacturer works continually to improve its products. As a result, the design and specifications of each product at the time of order may be changed without notice. Purchaser's approval of this data set signifies that the equipment is acceptable under the provisions of the job specification. Statements and other information contained herein are not express warranties and do not form the basis of any bargain between the parties, but are merely the manufacturer's opinion or commendation of its products. York and Affinity are registered trademarks of Johnson Controls, Inc., and are used with permission.